



Air Conditioners

Technical Data



Concealed floor standing unit

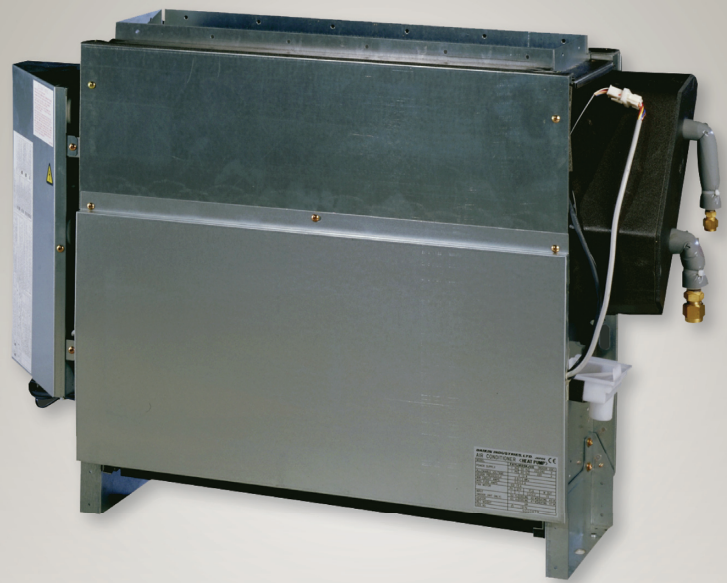

EEDEN11-204

FXNQ-P



Air Conditioners

Technical Data



Concealed floor standing unit

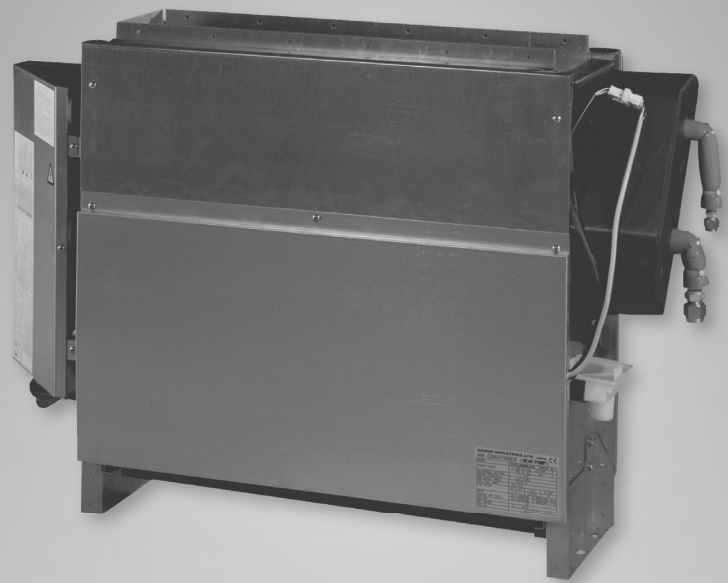

EEDEN11-204

FXNQ-P

TABLE OF CONTENTS

FXNQ-P

1	Specifications	2
	Technical Specifications	2
	Electrical Specifications	2
2	Electrical data.....	3
	Electrical Data	3
3	Safety device settings	4
	Safety Device Settings	4
4	Options	5
	Options	5
5	Capacity tables	6
	Cooling Capacity Tables	6
	Heating Capacity Tables	8
	Capacity Correction Factor high sensible mode	10
6	Dimensional drawings	11
	Dimensional Drawings	11
7	Centre of gravity	13
	Centre of Gravity	13
8	Piping diagrams	14
	Piping Diagrams	14
9	Wiring diagrams	15
	Wiring Diagrams - Single Phase	15
10	Sound data.....	16
	Sound Pressure Spectrum	16
11	Installation.....	18
	Suspension Bolt Pitch Position	18
	Service Space	19

1 Specifications

1

1-1 Technical Specifications				FXNQ20P	FXNQ25P	FXNQ32P	FXNQ40P	FXNQ50P	FXNQ63P	
Cooling capacity	Nom.		kW	2.2 (1)	2.8 (1)	3.6 (1)	4.5 (1)	5.6 (1)	7.1 (1)	
Heating capacity	Nom.		kW	2.5 (2)	3.2 (2)	4.0 (2)	5.0 (2)	6.3 (2)	8.0 (2)	
Power input - 50Hz	Cooling	Nom.	kW	0.049		0.090		0.110		
	Heating	Nom.	kW	0.049		0.090		0.110		
Casing	Material			Galvanised steel plate						
Dimensions	Unit	Height	mm	610						
		Width	mm	930		1,070		1,350		
		Depth	mm	220						
	Packed unit	Height	mm	665						
		Width	mm	1,128		1,268		1,548		
		Depth	mm	346						
Weight	Unit		kg	19		23		27		
	Packed unit		kg	26		31		36		
Heat exchanger	Rows	Quantity		3						
	Fin pitch		mm	1.5						
	Face area		m ²	0.159		0.200		0.282		
	Stages	Quantity		14						
Fan	Type			Sirocco fan						
	Air flow rate - 50Hz	Cooling	High	m ³ /min	7		8		11	
			Low	m ³ /min	6		8.5		11	
Fan motor	Output	High	W	15		25		35		
	Drive			Direct drive						
Sound pressure level	Cooling	High	dBA	35		38		39		
		Low	dBA	32		33		34		
Refrigerant	Type			R-410A						
	Control			Electronic expansion valve						
Piping connections	Liquid	Type		Flare connection						
		OD	mm	6.35				9.52		
	Gas	Type		Flare connection						
		OD	mm	12.7				15.9		
Heat insulation			Glass Fiber/Urethane Foam							
Temperature control				Microprocessor thermostat for cooling and heating						
Air filter				Resin net						
Safety devices	Item	01		PC board fuse						
		02		Fan motor thermal protection						

1-2 Electrical Specifications				FXNQ20P	FXNQ25P	FXNQ32P	FXNQ40P	FXNQ50P	FXNQ63P
Power supply	Phase			1~					
	Frequency		Hz	50/60					
	Voltage		V	220-240/220					
Current - 50Hz	Minimum circuit amps (MCA)		A	0.3		0.6			
	Maximum fuse amps (MFA)		A	15					
	Full load amps (FLA)	Total	A	0.2		0.5			

Notes

- (1) Cooling: indoor temp. 27°CDB, 19°CWB; outdoor temp. 35°CDB; equivalent piping length: 7.5m (horizontal)
- (2) Heating: indoor temp. 20°CDB; outdoor temp. 7°CDB, 6°CWB; equivalent refrigerant piping: 7.5m (horizontal)
- (3) Capacities are net, including a deduction for cooling (an addition for heating) for indoor fan motor heat.
- (4) Voltage range: units are suitable for use on electrical systems where voltage supplied to unit terminal is not below or above listed range limits.
- (5) Maximum allowable voltage range variation between phases is 2%.
- (6) MCA/MFA: MCA = 1.25 x FLA
- (7) MFA ≤ 4 x FLA
- (8) Next lower standard fuse rating minimum 15A
- (9) Select wire size based on the value of MCA
- (10) Use a circuit breaker instead of a fuse.

2

2 Electrical data

2 - 1 Electrical Data

FXNQ-P

Model	Units			Power supply		IFM		Input (W)	
	Hz	Volts	Voltage range	MCA	MFA	KW	FLA	Cooling	Heating
FXNQ20P	50	220-240	Max. 264 Min. 198	0.3	15	0.015	0.2	49	49
FXNQ25P				0.3	15	0.015	0.2	49	49
FXNQ32P				0.6	15	0.025	0.5	90	90
FXNQ40P				0.6	15	0.025	0.5	90	90
FXNQ50P				0.6	15	0.035	0.5	110	110
FXNQ63P				0.6	15	0.035	0.5	110	110

SYMBOLS

MCA : Min. Circuit Amps. (A)
MFA : Max. Fuse Amps. (See note 5)
kW : Fan Motor Rated Output (kW)
FLA : Full Load Amps. (A)
IFM : Indoor Fan Motor

NOTES

- Voltage range
Units are suitable for use on electrical systems where voltage supplied to unit terminals is not below or above listed range limits.
- Maximum allowable voltage unbalance between phases is 2%
- MCA/MFA
 $MCA + 1.25 \times FLA$
 $MFA \leq 4 \times FLA$
(next lower standard fuse rating. Min. 15A)
- Select wire size based on the MCA.
- Instead of fuse, use Circuit Breaker.

4D034579E

3 Safety device settings

3 - 1 Safety Device Settings

FXNQ-P

Safety devices		20	25	32	40	50	63
FXNQ-P	PC board fuse	250V 10A	250V 10A	250V 10A	250V 10A	250V 10A	250V 10A
	Fan motor thermal protector	°C OFF: 135 ±10 ON: 120 or less	°C OFF: 135 ±10 ON: 120 or less	°C OFF: 135 ±10 ON: 120 or less	°C OFF: 135 ±10 ON: 120 or less	°C OFF: 135 ±10 ON: 120 or less	°C OFF: 135 ±10 ON: 120 or less

3D034529F

3

4

4 Options

4 - 1 Options

Item		Type	FXNQ20,25P	FXNQ32,40P	FXNQ50,63P
Remote control	Wired type			BRC1D52 / BRC1E51A	
	Wireless type	HP		BRC4C65	
		CO		BRC4C66	
Simplified remote control				BRC2C51	
Remote control for hotel use				BRC3A61	
Adapter for wiring				KRP1B61	
Wiring adapter for electrical appendices (1)				KRP2A51	
Wiring adapter for electrical appendices (2)				KRP4A51	
Remote sensor				KRCS01-1	
Central remote control				DCS302C51	
Electrical box with earth terminal (3 blocks)				KJB311A	
Unified ON/OFF controller				DCS301BA51	
Electrical box with earth terminal (2 blocks)				KJB212A	
Noise filter (for electromagnetic interface use only)				KEK26-1	
Schedule timer				DST301B51	
External adapter for outdoor unit (installation on indoor unit)				DTA104A61	
Long life replacement filter			KAFJ361K28	KAFJ361K45	KAFJ361K71
Multi tenant *1				EKMTAC	

NOTES

*1 This kit contains parts to connect with 10 multi tenant indoor units.

4TW32299-1B

5 Capacity tables

5 - 1 Cooling Capacity Tables

5

FXNQ-P																
Unit size	Nominal capacity	Outdoor air temp. °CDB	Indoor air temperature													
			14.OWB		16.OWB		18.OWB		19.OWB		20.OWB		22.OWB		24.OWB	
			20.ODB		23.ODB		26.ODB		27.ODB		28.ODB		30.ODB		32.ODB	
			TC	SHC	TC	SHC	TC	SHC	TC	SHC	TC	SHC	TC	SHC	TC	SHC
20	2.2	10.0	1.5	1.3	1.8	1.5	2.1	1.7	2.2	1.7	2.3	1.8	2.6	1.8	2.9	1.8
		12.0	1.5	1.3	1.8	1.5	2.1	1.7	2.2	1.7	2.3	1.8	2.6	1.8	2.9	1.7
		14.0	1.5	1.3	1.8	1.5	2.1	1.7	2.2	1.7	2.3	1.8	2.6	1.8	2.8	1.7
		16.0	1.5	1.3	1.8	1.5	2.1	1.7	2.2	1.7	2.3	1.8	2.6	1.8	2.8	1.7
		18.0	1.5	1.3	1.8	1.5	2.1	1.7	2.2	1.7	2.3	1.8	2.6	1.8	2.7	1.7
		20.0	1.5	1.3	1.8	1.5	2.1	1.7	2.2	1.7	2.3	1.8	2.6	1.8	2.7	1.6
		21.0	1.5	1.3	1.8	1.5	2.1	1.7	2.2	1.7	2.3	1.8	2.6	1.8	2.7	1.6
		23.0	1.5	1.3	1.8	1.5	2.1	1.7	2.2	1.7	2.3	1.8	2.6	1.8	2.6	1.6
		25.0	1.5	1.3	1.8	1.5	2.1	1.7	2.2	1.7	2.3	1.8	2.6	1.7	2.6	1.6
		27.0	1.5	1.3	1.8	1.5	2.1	1.7	2.2	1.7	2.3	1.8	2.5	1.7	2.6	1.6
		29.0	1.5	1.3	1.8	1.5	2.1	1.7	2.2	1.7	2.3	1.8	2.5	1.7	2.5	1.6
		31.0	1.5	1.3	1.8	1.5	2.1	1.7	2.2	1.7	2.3	1.8	2.4	1.7	2.5	1.6
		33.0	1.5	1.3	1.8	1.5	2.1	1.7	2.2	1.7	2.3	1.8	2.4	1.7	2.5	1.6
25	2.8	10.0	1.9	1.6	2.3	1.8	2.6	2.0	2.8	2.1	3.0	2.1	3.4	2.1	3.7	2.1
		12.0	1.9	1.6	2.3	1.8	2.6	2.0	2.8	2.1	3.0	2.1	3.4	2.1	3.6	2.1
		14.0	1.9	1.6	2.3	1.8	2.6	2.0	2.8	2.1	3.0	2.1	3.4	2.1	3.6	2.1
		16.0	1.9	1.6	2.3	1.8	2.6	2.0	2.8	2.1	3.0	2.1	3.4	2.1	3.5	2.1
		18.0	1.9	1.6	2.3	1.8	2.6	2.0	2.8	2.1	3.0	2.1	3.4	2.1	3.5	2.0
		20.0	1.9	1.6	2.3	1.8	2.6	2.0	2.8	2.1	3.0	2.1	3.4	2.1	3.4	2.0
		21.0	1.9	1.6	2.3	1.8	2.6	2.0	2.8	2.1	3.0	2.1	3.4	2.1	3.4	2.0
		23.0	1.9	1.6	2.3	1.8	2.6	2.0	2.8	2.1	3.0	2.1	3.3	2.1	3.4	2.0
		25.0	1.9	1.6	2.3	1.8	2.6	2.0	2.8	2.1	3.0	2.1	3.3	2.1	3.3	2.0
		27.0	1.9	1.6	2.3	1.8	2.6	2.0	2.8	2.1	3.0	2.1	3.2	2.1	3.3	1.9
		29.0	1.9	1.6	2.3	1.8	2.6	2.0	2.8	2.1	3.0	2.1	3.2	2.0	3.2	1.9
		31.0	1.9	1.6	2.3	1.8	2.6	2.0	2.8	2.1	3.0	2.1	3.1	2.0	3.2	1.9
		33.0	1.9	1.6	2.3	1.8	2.6	2.0	2.8	2.1	3.0	2.1	3.1	2.0	3.1	1.9
35.0	1.9	1.6	2.3	1.8	2.6	2.0	2.8	2.1	3.0	2.1	3.0	2.0	3.1	1.9		
32	3.6	10.0	2.4	2.1	2.9	2.2	3.4	2.5	3.6	2.5	3.8	2.6	4.3	2.6	4.7	2.6
		12.0	2.4	2.1	2.9	2.2	3.4	2.5	3.6	2.5	3.8	2.6	4.3	2.6	4.7	2.6
		14.0	2.4	2.1	2.9	2.2	3.4	2.5	3.6	2.5	3.8	2.6	4.3	2.6	4.6	2.6
		16.0	2.4	2.1	2.9	2.2	3.4	2.5	3.6	2.5	3.8	2.6	4.3	2.6	4.6	2.5
		18.0	2.4	2.1	2.9	2.2	3.4	2.5	3.6	2.5	3.8	2.6	4.3	2.6	4.5	2.5
		20.0	2.4	2.1	2.9	2.2	3.4	2.5	3.6	2.5	3.8	2.6	4.3	2.6	4.4	2.5
		21.0	2.4	2.1	2.9	2.2	3.4	2.5	3.6	2.5	3.8	2.6	4.3	2.6	4.4	2.5
		23.0	2.4	2.1	2.9	2.2	3.4	2.5	3.6	2.5	3.8	2.6	4.2	2.6	4.3	2.4
		25.0	2.4	2.1	2.9	2.2	3.4	2.5	3.6	2.5	3.8	2.6	4.2	2.6	4.3	2.4
		27.0	2.4	2.1	2.9	2.2	3.4	2.5	3.6	2.5	3.8	2.6	4.1	2.5	4.2	2.4
		29.0	2.4	2.1	2.9	2.2	3.4	2.5	3.6	2.5	3.8	2.6	4.1	2.5	4.2	2.4
		31.0	2.4	2.1	2.9	2.2	3.4	2.5	3.6	2.5	3.8	2.6	4.0	2.5	4.1	2.4
		33.0	2.4	2.1	2.9	2.2	3.4	2.5	3.6	2.5	3.8	2.6	3.9	2.4	4.0	2.3
35.0	2.4	2.1	2.9	2.2	3.4	2.5	3.6	2.5	3.8	2.5	3.9	2.4	4.0	2.3		
40	4.5	10.0	3.0	2.5	3.6	2.7	4.2	3.1	4.5	3.1	4.8	3.2	5.4	3.3	5.9	3.3
		12.0	3.0	2.5	3.6	2.7	4.2	3.1	4.5	3.1	4.8	3.2	5.4	3.3	5.8	3.3
		14.0	3.0	2.5	3.6	2.7	4.2	3.1	4.5	3.1	4.8	3.2	5.4	3.3	5.8	3.2
		16.0	3.0	2.5	3.6	2.7	4.2	3.1	4.5	3.1	4.8	3.2	5.4	3.3	5.7	3.2
		18.0	3.0	2.5	3.6	2.7	4.2	3.1	4.5	3.1	4.8	3.2	5.4	3.3	5.6	3.1
		20.0	3.0	2.5	3.6	2.7	4.2	3.1	4.5	3.1	4.8	3.2	5.4	3.3	5.5	3.1
		21.0	3.0	2.5	3.6	2.7	4.2	3.1	4.5	3.1	4.8	3.2	5.4	3.3	5.5	3.1
		23.0	3.0	2.5	3.6	2.7	4.2	3.1	4.5	3.1	4.8	3.2	5.3	3.2	5.4	3.0
		25.0	3.0	2.5	3.6	2.7	4.2	3.1	4.5	3.1	4.8	3.2	5.2	3.2	5.3	3.0
		27.0	3.0	2.5	3.6	2.7	4.2	3.1	4.5	3.1	4.8	3.2	5.2	3.1	5.3	3.0
		29.0	3.0	2.5	3.6	2.7	4.2	3.1	4.5	3.1	4.8	3.2	5.1	3.1	5.2	3.0
		31.0	3.0	2.5	3.6	2.7	4.2	3.1	4.5	3.1	4.8	3.2	5.0	3.1	5.1	2.9
		33.0	3.0	2.5	3.6	2.7	4.2	3.1	4.5	3.1	4.8	3.2	4.9	3.0	5.0	2.9
35.0	3.0	2.5	3.6	2.7	4.2	3.1	4.5	3.1	4.7	3.2	4.9	3.1	5.0	2.9		
37.0	3.0	2.5	3.6	2.7	4.2	3.1	4.5	3.1	4.7	3.2	4.8	3.0	4.9	2.8		
39.0	3.0	2.5	3.6	2.7	4.2	3.1	4.5	3.2	4.6	3.1	4.7	3.0	4.8	2.8		

CA03A095

6

5 Capacity tables

5 - 1 Cooling Capacity Tables

FXNQ-P		TC: Total capacity;kW - SHC: Sensible capacity;kW															
Unit size	Nominal capacity	Outdoor air temp.	Indoor air temperature														
			14.OWB		16.OWB		18.OWB		19.OWB		20.OWB		22.OWB		24.OWB		
			20.ODB		23.ODB		26.ODB		27.ODB		28.ODB		30.ODB		32.ODB		
		°CDB	TC	SHC	TC	SHC	TC	SHC	TC	SHC	TC	SHC	TC	SHC	TC	SHC	
50	5.6	10.0	3.8	3.0	4.5	3.4	5.2	3.8	5.6	3.9	6.0	4.0	6.7	4.1	7.4	4.1	
		12.0	3.8	3.0	4.5	3.4	5.2	3.8	5.6	3.9	6.0	4.0	6.7	4.1	7.3	4.1	
		14.0	3.8	3.0	4.5	3.4	5.2	3.8	5.6	3.9	6.0	4.0	6.7	4.1	7.2	4.0	
		16.0	3.8	3.0	4.5	3.4	5.2	3.8	5.6	3.9	6.0	4.0	6.7	4.1	7.1	4.0	
		18.0	3.8	3.0	4.5	3.4	5.2	3.8	5.6	3.9	6.0	4.0	6.7	4.1	7.0	3.9	
		20.0	3.8	3.0	4.5	3.4	5.2	3.8	5.6	3.9	6.0	4.0	6.7	4.1	6.9	3.9	
		21.0	3.8	3.0	4.5	3.4	5.2	3.8	5.6	3.9	6.0	4.0	6.7	4.1	6.8	3.8	
		23.0	3.8	3.0	4.5	3.4	5.2	3.8	5.6	3.9	6.0	4.0	6.6	4.0	6.7	3.8	
		25.0	3.8	3.0	4.5	3.4	5.2	3.8	5.6	3.9	6.0	4.0	6.5	4.0	6.6	3.7	
		27.0	3.8	3.0	4.5	3.4	5.2	3.8	5.6	3.9	6.0	4.0	6.4	3.9	6.6	3.7	
		29.0	3.8	3.0	4.5	3.4	5.2	3.8	5.6	3.9	6.0	4.0	6.3	3.9	6.5	3.7	
		31.0	3.8	3.0	4.5	3.4	5.2	3.8	5.6	3.9	6.0	4.0	6.2	3.8	6.4	3.7	
		33.0	3.8	3.0	4.5	3.4	5.2	3.8	5.6	3.9	6.0	4.0	6.1	3.8	6.3	3.6	
		35.0	3.8	3.0	4.5	3.4	5.2	3.8	5.6	3.9	6.0	4.0	6.0	3.8	6.2	3.6	
		37.0	3.8	3.0	4.5	3.4	5.2	3.8	5.6	3.9	5.8	3.9	5.9	3.7	6.1	3.6	
		39.0	3.8	3.0	4.5	3.4	5.2	3.8	5.6	3.9	5.7	3.9	5.8	3.7	6.0	3.5	
63	7.1	10.0	4.8	3.7	5.7	4.2	6.6	4.8	7.1	4.9	7.6	5.0	8.5	5.1	9.3	5.0	
		12.0	4.8	3.7	5.7	4.2	6.6	4.8	7.1	4.9	7.6	5.0	8.5	5.1	9.2	5.0	
		14.0	4.8	3.7	5.7	4.2	6.6	4.8	7.1	4.9	7.6	5.0	8.5	5.1	9.1	4.9	
		16.0	4.8	3.7	5.7	4.2	6.6	4.8	7.1	4.9	7.6	5.0	8.5	5.1	9.0	4.8	
		18.0	4.8	3.7	5.7	4.2	6.6	4.8	7.1	4.9	7.6	5.0	8.5	5.1	8.8	4.8	
		20.0	4.8	3.7	5.7	4.2	6.6	4.8	7.1	4.9	7.6	5.0	8.5	5.1	8.7	4.7	
		21.0	4.8	3.7	5.7	4.2	6.6	4.8	7.1	4.9	7.6	5.0	8.5	5.1	8.7	4.7	
		23.0	4.8	3.7	5.7	4.2	6.6	4.8	7.1	4.9	7.6	5.0	8.4	5.0	8.5	4.6	
		25.0	4.8	3.7	5.7	4.2	6.6	4.8	7.1	4.9	7.6	5.0	8.3	5.0	8.4	4.5	
		27.0	4.8	3.7	5.7	4.2	6.6	4.8	7.1	4.9	7.6	5.0	8.1	4.9	8.3	4.5	
		29.0	4.8	3.7	5.7	4.2	6.6	4.8	7.1	4.9	7.6	5.0	8.0	4.8	8.2	4.5	
		31.0	4.8	3.7	5.7	4.2	6.6	4.8	7.1	4.9	7.6	5.0	7.9	4.7	8.1	4.4	
		33.0	4.8	3.7	5.7	4.2	6.6	4.8	7.1	4.9	7.6	5.0	7.8	4.7	7.9	4.4	
		35.0	4.8	3.7	5.7	4.2	6.6	4.8	7.1	4.9	7.5	4.9	7.7	4.7	7.8	4.3	
		37.0	4.8	3.7	5.7	4.2	6.6	4.8	7.1	4.9	7.4	4.9	7.5	4.6	7.7	4.2	
		39.0	4.8	3.7	5.7	4.2	6.6	4.8	7.1	4.9	7.2	4.8	7.4	4.6	7.6	4.2	

CA03A095

5 Capacity tables

5 - 2 Heating Capacity Tables

5

FXNQ-P									
Unit Size	Nominal capacity	Outdoor air temperature		Indoor air temperature °CDB					
				16.0	18.0	20.0	21.0	22.0	24.0
		°CDB	°CWB	kW	kW	kW	kW	kW	kW
20	2.5	-19.8	-20.0	1.5	1.5	1.5	1.5	1.5	1.5
		-18.8	-19.0	1.5	1.5	1.5	1.5	1.5	1.5
		-16.7	-17.0	1.6	1.6	1.6	1.6	1.6	1.6
		-14.7	-15.0	1.7	1.7	1.7	1.7	1.7	1.7
		-12.6	-13.0	1.8	1.8	1.8	1.8	1.8	1.8
		-10.5	-11.0	1.9	1.9	1.9	1.9	1.9	1.9
		-9.5	-10.0	1.9	1.9	1.9	1.9	1.9	1.9
		-8.5	-9.1	2.0	2.0	1.9	1.9	1.9	1.9
		-7.0	-7.6	2.0	2.0	2.0	2.0	2.0	2.0
		-5.0	-5.6	2.1	2.1	2.1	2.1	2.1	2.1
		-3.0	-3.7	2.2	2.2	2.2	2.2	2.2	2.2
		0.0	-0.7	2.3	2.3	2.3	2.3	2.3	2.2
		3.0	2.2	2.5	2.5	2.4	2.4	2.3	2.2
		5.0	4.1	2.5	2.5	2.5	2.4	2.3	2.2
		7.0	6.0	2.6	2.6	2.5	2.4	2.3	2.2
		9.0	7.9	2.7	2.7	2.5	2.4	2.3	2.2
		11.0	9.8	2.8	2.7	2.5	2.4	2.3	2.2
13.0	11.8	2.8	2.7	2.5	2.4	2.3	2.2		
15.0	13.7	2.8	2.7	2.5	2.4	2.3	2.2		
25	3.2	-19.8	-20.0	1.9	1.9	1.9	1.9	1.9	1.9
		-18.8	-19.0	1.9	1.9	1.9	1.9	1.9	1.9
		-16.7	-17.0	2.1	2.1	2.0	2.0	2.0	2.0
		-14.7	-15.0	2.2	2.2	2.2	2.2	2.2	2.1
		-12.6	-13.0	2.3	2.3	2.3	2.3	2.3	2.3
		-10.5	-11.0	2.4	2.4	2.4	2.4	2.4	2.4
		-9.5	-10.0	2.5	2.4	2.4	2.4	2.4	2.4
		-8.5	-9.1	2.5	2.5	2.5	2.5	2.5	2.5
		-7.0	-7.6	2.6	2.6	2.6	2.6	2.6	2.6
		-5.0	-5.6	2.7	2.7	2.7	2.7	2.7	2.7
		-3.0	-3.7	2.8	2.8	2.8	2.8	2.8	2.8
		0.0	-0.7	3.0	3.0	3.0	3.0	3.0	2.8
		3.0	2.2	3.1	3.1	3.1	3.1	3.0	2.8
		5.0	4.1	3.3	3.2	3.2	3.1	3.0	2.8
		7.0	6.0	3.4	3.4	3.2	3.1	3.0	2.8
		9.0	7.9	3.5	3.4	3.2	3.1	3.0	2.8
		11.0	9.8	3.6	3.4	3.2	3.1	3.0	2.8
13.0	11.8	3.6	3.4	3.2	3.1	3.0	2.8		
15.0	13.7	3.6	3.4	3.2	3.1	3.0	2.8		
32	4.0	-19.8	-20.0	2.4	2.4	2.3	2.3	2.3	2.3
		-18.8	-19.0	2.4	2.4	2.4	2.4	2.4	2.4
		-16.7	-17.0	2.6	2.6	2.6	2.6	2.6	2.5
		-14.7	-15.0	2.7	2.7	2.7	2.7	2.7	2.7
		-12.6	-13.0	2.9	2.8	2.8	2.8	2.8	2.8
		-10.5	-11.0	3.0	3.0	3.0	3.0	3.0	3.0
		-9.5	-10.0	3.1	3.1	3.1	3.1	3.0	3.0
		-8.5	-9.1	3.1	3.1	3.1	3.1	3.1	3.1
		-7.0	-7.6	3.2	3.2	3.2	3.2	3.2	3.2
		-5.0	-5.6	3.4	3.4	3.4	3.4	3.4	3.4
		-3.0	-3.7	3.5	3.5	3.5	3.5	3.5	3.5
		0.0	-0.7	3.7	3.7	3.7	3.7	3.7	3.5
		3.0	2.2	3.9	3.9	3.9	3.9	3.7	3.5
		5.0	4.1	4.1	4.1	4.0	3.9	3.7	3.5
		7.0	6.0	4.2	4.2	4.0	3.9	3.7	3.5
		9.0	7.9	4.3	4.3	4.0	3.9	3.7	3.5
		11.0	9.8	4.5	4.3	4.0	3.9	3.7	3.5
13.0	11.8	4.5	4.3	4.0	3.9	3.7	3.5		
15.0	13.7	4.5	4.3	4.0	3.9	3.7	3.5		
40	5.0	-19.8	-20.0	3.0	2.9	2.9	2.9	2.9	2.9
		-18.8	-19.0	3.0	3.0	3.0	3.0	3.0	3.0
		-16.7	-17.0	3.2	3.2	3.2	3.2	3.2	3.2
		-14.7	-15.0	3.4	3.4	3.4	3.4	3.4	3.4
		-12.6	-13.0	3.6	3.6	3.6	3.5	3.5	3.5
		-10.5	-11.0	3.7	3.7	3.7	3.7	3.7	3.7
		-9.5	-10.0	3.8	3.8	3.8	3.8	3.8	3.8
		-8.5	-9.1	3.9	3.9	3.9	3.9	3.9	3.9
		-7.0	-7.6	4.0	4.0	4.0	4.0	4.0	4.0
		-5.0	-5.6	4.2	4.2	4.2	4.2	4.2	4.2
		-3.0	-3.7	4.4	4.4	4.4	4.4	4.4	4.4
		0.0	-0.7	4.7	4.6	4.6	4.6	4.6	4.4
		3.0	2.2	4.9	4.9	4.9	4.8	4.7	4.4
		5.0	4.1	5.1	5.1	5.0	4.8	4.7	4.4
		7.0	6.0	5.2	5.2	5.0	4.8	4.7	4.4
		9.0	7.9	5.4	5.3	5.0	4.8	4.7	4.4
		11.0	9.8	5.6	5.3	5.0	4.8	4.7	4.4
13.0	11.8	5.6	5.3	5.0	4.8	4.7	4.4		
15.0	13.7	5.6	5.3	5.0	4.8	4.7	4.4		

CA03A095

5 Capacity tables

5 - 2 Heating Capacity Tables

FXNQ-P										
Unit Size	Nominal capacity	Outdoor air temperature		Indoor air temperature °CDB						
				16.0	18.0	20.0		21.0	22.0	24.0
		°CDB	°CWB	kW	kW	kW	kW	kW	kW	kW
50	6.3	-19.8	-20.0	3.7	3.7	3.7	3.7	3.7	3.7	3.7
		-18.8	-19.0	3.8	3.8	3.8	3.8	3.8	3.8	3.8
		-16.7	-17.0	4.1	4.0	4.0	4.0	4.0	4.0	4.0
		-14.7	-15.0	4.3	4.3	4.3	4.2	4.2	4.2	4.2
		-12.6	-13.0	4.5	4.5	4.5	4.5	4.5	4.5	4.5
		-10.5	-11.0	4.7	4.7	4.7	4.7	4.7	4.7	4.7
		-9.5	-10.0	4.8	4.8	4.8	4.8	4.8	4.8	4.8
		-8.5	-9.1	4.9	4.9	4.9	4.9	4.9	4.9	4.9
		-7.0	-7.6	5.1	5.1	5.1	5.1	5.1	5.1	5.1
		-5.0	-5.6	5.3	5.3	5.3	5.3	5.3	5.3	5.3
		-3.0	-3.7	5.5	5.5	5.5	5.5	5.5	5.5	5.5
		0.0	-0.7	5.9	5.9	5.8	5.8	5.8	5.8	5.5
		3.0	2.2	6.2	6.2	6.2	6.1	5.9	5.5	5.5
		5.0	4.1	6.4	6.4	6.3	6.1	5.9	5.5	5.5
		7.0	6.0	6.6	6.6	6.3	6.1	5.9	5.5	5.5
		9.0	7.9	6.8	6.7	6.3	6.1	5.9	5.5	5.5
11.0	9.8	7.0	6.7	6.3	6.1	5.9	5.5	5.5		
13.0	11.8	7.1	6.7	6.3	6.1	5.9	5.5	5.5		
15.0	13.7	7.1	6.7	6.3	6.1	5.9	5.5	5.5		
63	8.0	-19.8	-20.0	4.7	4.7	4.7	4.7	4.7	4.7	4.7
		-18.8	-19.0	4.9	4.9	4.8	4.8	4.8	4.8	4.8
		-16.7	-17.0	5.1	5.1	5.1	5.1	5.1	5.1	5.1
		-14.7	-15.0	5.4	5.4	5.4	5.4	5.4	5.4	5.4
		-12.6	-13.0	5.7	5.7	5.7	5.7	5.7	5.7	5.7
		-10.5	-11.0	6.0	6.0	6.0	6.0	6.0	6.0	5.9
		-9.5	-10.0	6.1	6.1	6.1	6.1	6.1	6.1	6.1
		-8.5	-9.1	6.3	6.3	6.2	6.2	6.2	6.2	6.2
		-7.0	-7.6	6.5	6.5	6.4	6.4	6.4	6.4	6.4
		-5.0	-5.6	6.8	6.7	6.7	6.7	6.7	6.7	6.7
		-3.0	-3.7	7.0	7.0	7.0	7.0	7.0	7.0	7.0
		0.0	-0.7	7.5	7.4	7.4	7.4	7.4	7.4	7.0
		3.0	2.2	7.9	7.8	7.8	7.7	7.5	7.0	7.0
		5.0	4.1	8.1	8.1	8.0	7.7	7.5	7.0	7.0
		7.0	6.0	8.4	8.4	8.0	7.7	7.5	7.0	7.0
		9.0	7.9	8.7	8.5	8.0	7.7	7.5	7.0	7.0
11.0	9.8	8.9	8.5	8.0	7.7	7.5	7.0	7.0		
13.0	11.8	9.0	8.5	8.0	7.7	7.5	7.0	7.0		
15.0	13.7	9.0	8.5	8.0	7.7	7.5	7.0	7.0		

CA03A095

5 Capacity tables

5 - 3 Capacity Correction Factor high sensible mode

FXNQ-P

		Single module and 2 module systems (not applicable for 3 module systems)						
		20°CDB 14°CWB	23°CDB 16°CWB	26°CDB 18°CWB	27°CDB 19°CWB	28°CDB 20°CWB	30°CDB 22°CWB	32°CDB 24°CWB
20	TC ratio	0,527	0,540	0,601	0,638	0,671	0,727	0,768
	SHF ratio	1,205	1,300	1,249	1,196	1,157	1,101	1,063
25	TC ratio	0,527	0,542	0,604	0,642	0,675	0,730	0,771
	SHF ratio	1,206	1,301	1,247	1,194	1,155	1,099	1,063
32	TC ratio	0,525	0,538	0,600	0,637	0,669	0,725	0,769
	SHF ratio	1,212	1,308	1,249	1,197	1,158	1,100	1,061
40	TC ratio	0,533	0,553	0,610	0,648	0,681	0,731	0,771
	SHF ratio	1,184	1,274	1,238	1,187	1,150	1,100	1,070
50	TC ratio	0,530	0,545	0,601	0,639	0,672	0,727	0,768
	SHF ratio	1,194	1,288	1,247	1,195	1,156	1,101	1,064
63	TC ratio	0,535	0,553	0,608	0,646	0,678	0,729	0,769
	SHF ratio	1,179	1,269	1,238	1,188	1,151	1,103	1,075

4TW27232-9

NOTES - ANMERKUNGEN - Σημειώσεις - NOTAS - REMARQUES - NOTE - OPMERKINGEN - Примечания - NOTLAR

How to use this table - So verwenden Sie diese Tabelle - Πώς θα χρησιμοποιήσετε αυτό τον πίνακα - Cómo utilizar esta tabla - Utilisation de ce tableau - Come utilizzare questa tabella - Gebruik van deze tabel - Как пользоваться этой таблицей - Bu tablo nasıl kullanılmalı?:

1. Capacity : Total capacity for High sensible mode = Total capacity for normal capacity table X TC ratio.

Leistung: Gesamtleistung für hochfühlbaren Leistungsmodus = Gesamtleistung für normale Leistungstabelle x GL-Verhältnis.

Απόδοση: Συνολική απόδοση για τη λειτουργία υψηλής ευαισθησίας = Συνολική απόδοση για τον πίνακα κανονικών αποδόσεων X αναλογία TC

Capacidad: Capacidad total para el modo de alta sensibilidad = Capacidad total para la tabla de capacidad normal X relación TC.

Capacité sensible (FCS (Facteur de chaleur sensible) – en anglais : SHF) : FCS pour le mode sensibilité élevée (« High ») = FCS du tableau des capacités normales x rapport FCS.

Capacità: Capacità totale per modalità ad alta capacità sensibile = Capacità totale per tabella capacità normali X rapporto TC.

Capaciteit: totale capaciteit in modus grote ("High") gevoeligheid = totale capaciteit uit de tabel met normale capaciteiten x TC-ratio.

Производительность: Общая производительность для режима с высоким коэфф. ошутимого охлаждения = Общая производительность для нормального режима, таблица X коэфф. TC.

Kapasite: Yüksek algı modu için toplam kapasite = Normal kapasite tablosundaki toplam kapasite değeri x TC oranı.

2. Sensible capacity (SHF): SHF for High sensible mode = SHF for normal capacity table X SHF ratio .

Fühlbare Leistung (SHF): SHF für hochfühlbaren Leistungsmodus = SHF für normale Leistungstabelle x SHF-Verhältnis.

Αισθητή απόδοση (SHF): SHF για λειτουργία υψηλής ευαισθησίας = SHF για πίνακα κανονικών αποδόσεων X αναλογία SHF .

Capacidad sensible (FCS): SHF para el modo de alta sensibilidad = SHF para la tabla de capacidad normal X relación SHF.

Capacité sensible (FCS (Facteur de chaleur sensible) – en anglais : SHF) : FCS pour le mode sensibilité élevée (« High ») = FCS du tableau des capacités normales x rapport FCS.

Capacità sensibile (SHF): SHF per modalità ad alta capacità sensibile = SHF per tabella capacità normali X rapporto SHF.

Gevoeligheidscapaciteit (WGF (warmtegevoelsfactor)– in het Engels "SHF"): WGF voor de modus grote ("High") gevoeligheid = WGF uit de tabel met normale capaciteiten x WGF-ratio.

Ошутимая производительность (SHF): SHF для режима с высоким коэфф. ошутимого охлаждения = SHF для нормального режима, таблица X коэфф. SHF.

Algılanabilir kapasite (SHF): Yüksek algı modu için SHF = Normal kapasite tablosundaki SHF değeri x SHF oranı.

3. In case of SHF is bigger than 1 , SHF is "1"

Für den Fall, dass SHF größer als 1 ist, wird SHF als "1" angenommen.

Σε περίπτωση που το SHF είναι μεγαλύτερο από 1, το SHF είναι "1"

En caso de que SHF sea superior a 1 , SHF equivale a "1"

Si FCS est supérieur à 1, utilisez « 1 » pour FCS.

Qualora il valore SHF sia maggiore di 1 , SHF è "1"

Indien WGF groter is dan 1, neem dan "1" voor WGF.

Если SHF больше 1, то SHF равен "1"

SHF değeri 1'den büyükse, SHF değeri "1" kabul edilmelidir

6 Dimensional drawings

6 - 1 Dimensional Drawings

FXNQ20-25P

Top plate
 (Discharge flange)
 200
 562
 159
 42
 130
 35

6 x Ø4.7 Hole
 620
 5 x 100 = 500
 24
 11
 609
 387
 192
 233
 141
 42
 590
 42

4-12x30 Oblong hole
 Hole for floor mounting

Level adjusting screw
 In standard accessory
 4xM6

2-12x18 Oblong hole
 Hole for fixing to the floor

219
 141
 86
 65
 75
 2 x Ø4.7 Hole
 396
 302
 83
 8
 101
 150
 202

Required installation space
 Discharge
 Suction
 Front of face
 100 or more
 20 or more
 150 or more
 150 or more
 Base

Nr	Name	Description
1	Liquid pipe connection	Ø6.4 Flare connection
2	Gas pipe connection	Ø12.7 Flare connection
3	Drain pipe connection	O.D. Ø21
4	Switch box	
5	Air filter	

3TW32834-1

FXNQ32-40P

Top plate
 (Discharge flange)
 200
 702
 159
 42
 130
 35

7 x Ø4.7 Hole
 760
 6 x 100 = 600
 24
 11
 609
 387
 192
 233
 141
 42
 730
 42

4-12x30 Oblong hole
 Hole for floor mounting

Level adjusting screw
 In standard accessory
 4xM6

2-12x18 Oblong hole
 Hole for fixing to the floor

219
 141
 86
 65
 75
 2 x Ø4.7 Hole
 396
 302
 83
 8
 101
 150
 202

Required installation space
 Discharge
 Suction
 Front of face
 100 or more
 20 or more
 150 or more
 150 or more
 Base

Nr	Name	Description
1	Liquid pipe connection	Ø6.4 Flare connection
2	Gas pipe connection	Ø12.7 Flare connection
3	Drain pipe connection	O.D. Ø21
4	Switch box	
5	Air filter	

3TW32854-1

6 Dimensional drawings

6 - 1 Dimensional Drawings

6

FXNQ50-63P

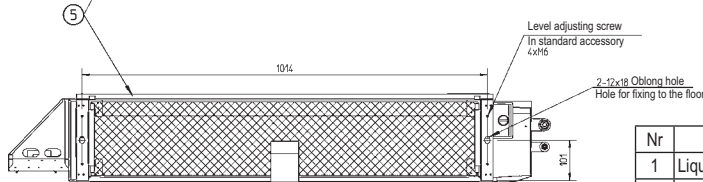
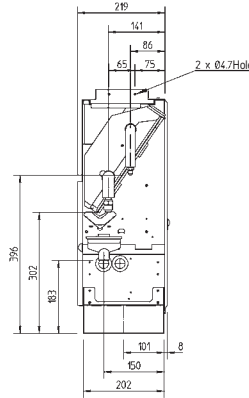
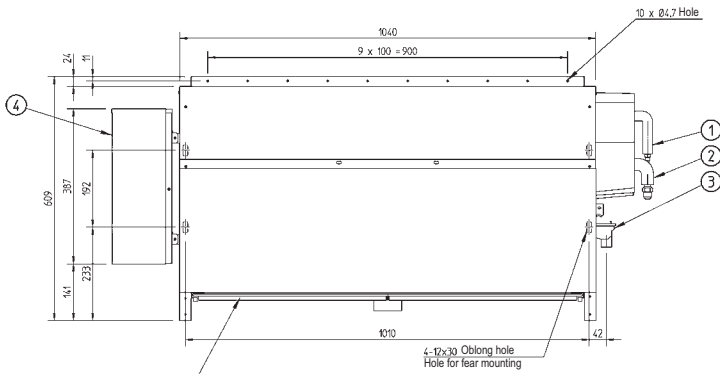
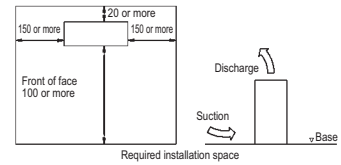
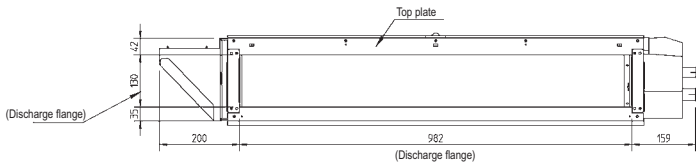

Model	A	B
FXNQ50	Ø6.4	Ø12.7
FXNQ63	Ø9.5	Ø15.9

Nr	Name	Description
1	Liquid pipe connection	Ø A Flare connection
2	Gas pipe connection	Ø B Flare connection
3	Drain pipe connection	O.D. Ø21
4	Switch box	
5	Air filter	

3TW32874-1

7 Centre of gravity

7 - 1 Centre of Gravity

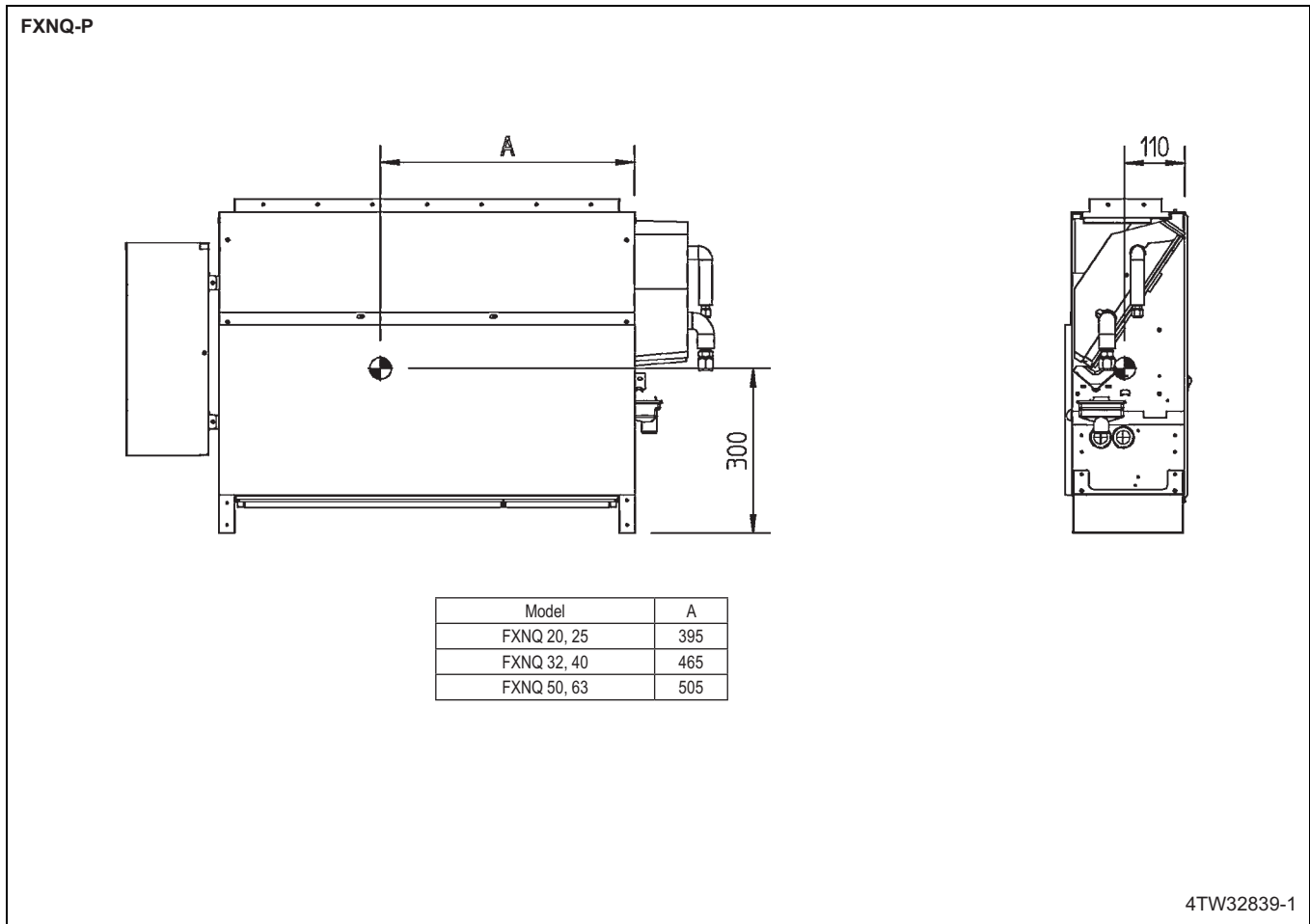

7

8 Piping diagrams

8 - 1 Piping Diagrams

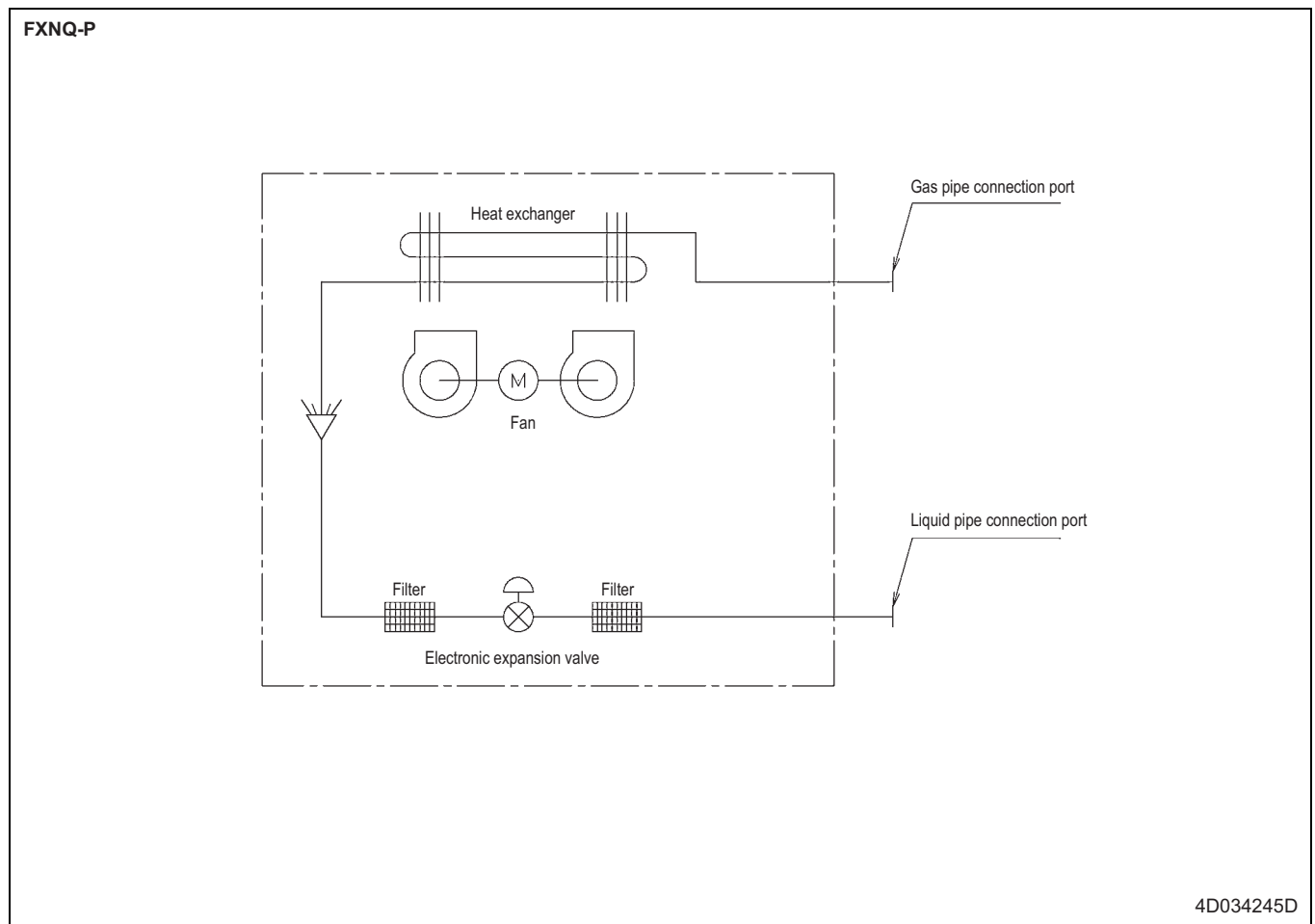

9 Wiring diagrams

9 - 1 Wiring Diagrams - Single Phase

FXNQ-P

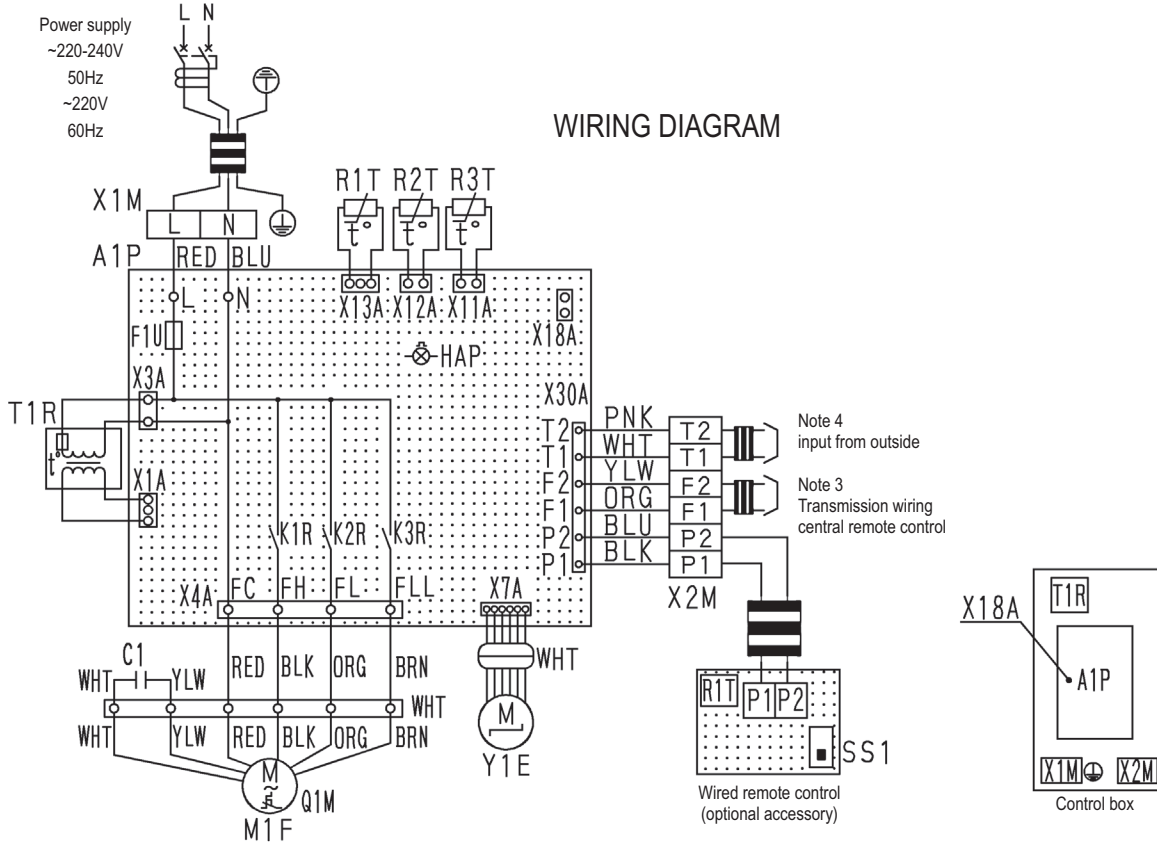

Indoor unit		R2T - R3T	Thermistor (Coil)
A1P	Printed Circuit Board	T1R	Transformer (220-240V/22V)
C1	Capacitor (M1F)	X1M	Terminal block (Power)
F1U	Fuse (B , 5A, 250V)	X2M	Terminal block (Control)
HAP	Light Emitting diode Service Monitor-Green)	Y1E	Electronic expansion valve
Wired Remote Control			
K1R-K3R	Magnetic relay (M1F)	R1T	Thermistor (Air)
M1F	Motor (Indoor fan)	SS1	Selector switch (main/sub)
Q1M	Thermo Switch (M1F Embedded)	Connector for optional parts	
R1T	Thermistor (Air)	X18A	Connector (Wiring adapter for Electrical appendices

3D039826F

NOTES

- : Terminal strip □□□, ▷-: connector -○-: terminal
- ⚡ : Field wiring
- In case using central remote control, connect it to the unit in accordance with the attached instructio manual.
- When connecting the input wires from outside, forced OFF or ON/OFF control operation can be selected by remote control, in details, refer to the installation manual attached the unit.
- Symbols show as follows. (PNK: Pink, WHT: White, YLW: Yellow, ORG: Orange, BLU: Blue, BLK: Black, RED: Red, BRN: Brown)
- Use copper conductors only.

10 Sound data

10 - 1 Sound Pressure Spectrum

10

FXNQ20-25P

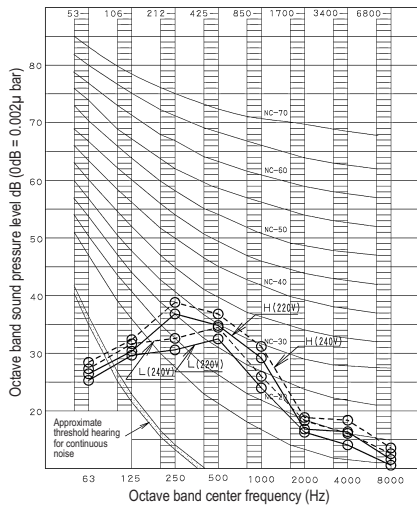

4D034534B

NOTES

- Over All (dB): (B,G,N is already rectified)
- Operating conditions:
Power source: 220 - 240V/22V 50/60Hz
JIS standard
- — 220V ○ - - - - ○ 240V
- Measuring place: Anechoic chamber
- Operation noise differs with operation and ambient conditions
- Location of microphone.

Scale	220V		240V	
	H	L	H	L
A	35	32	37	34
C	40	36.5	42	38.5

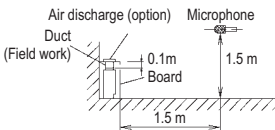

FXNQ32P

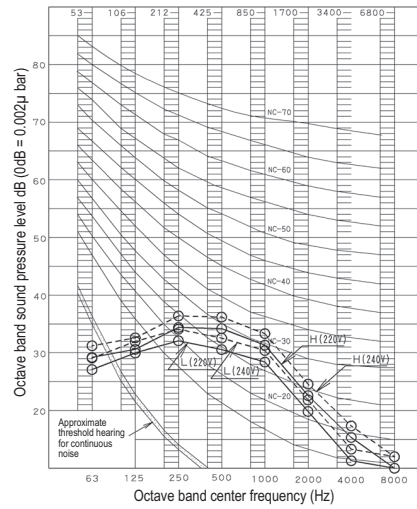

4D034535A

NOTES

- Over All (dB): (B,G,N is already rectified)
- Operating conditions:
Power source: 220 - 240V/22V 50/60Hz
JIS standard
- — 220V ○ - - - - ○ 240V
- Measuring place: Anechoic chamber
- Operation noise differs with operation and ambient conditions
- Location of microphone.

Scale	220V		240V	
	H	L	H	L
A	35	32	37	34
C	39	37	41	39

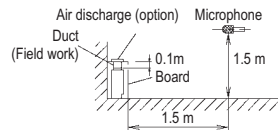

FXNQ40P

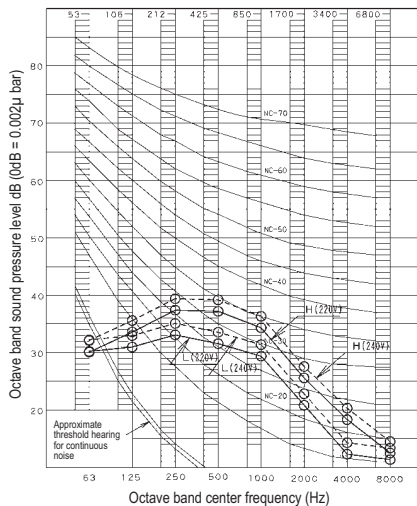

4D034536B

NOTES

- Over All (dB): (B,G,N is already rectified)
- Operating conditions:
Power source: 220 - 240V/22V 50/60Hz
JIS standard
- — 220V ○ - - - - ○ 240V
- Measuring place: Anechoic chamber
- Operation noise differs with operation and ambient conditions
- Location of microphone.

Scale	220V		240V	
	H	L	H	L
A	38	33	40	35
C	42	38	44	40

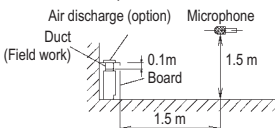

FXNQ50P

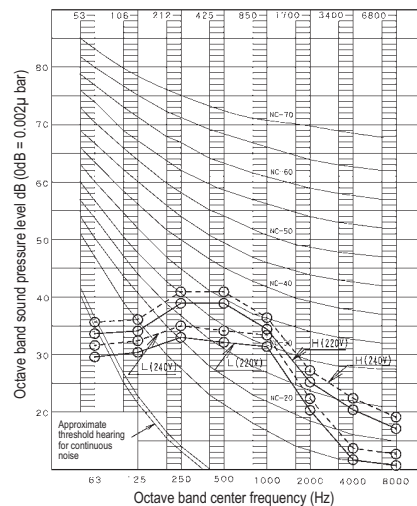

4D034537B

NOTES

- Over All (dB): (B,G,N is already rectified)
- Operating conditions:
Power source: 220 - 240V/22V 50/60Hz
JIS standard
- — 220V ○ - - - - ○ 240V
- Measuring place: Anechoic chamber
- Operation noise differs with operation and ambient conditions
- Location of microphone.

Scale	220V		240V	
	H	L	H	L
A	39	34	41	36
C	44	38.5	46	40.5

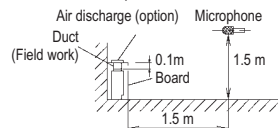

10 Sound data

10 - 1 Sound Pressure Spectrum

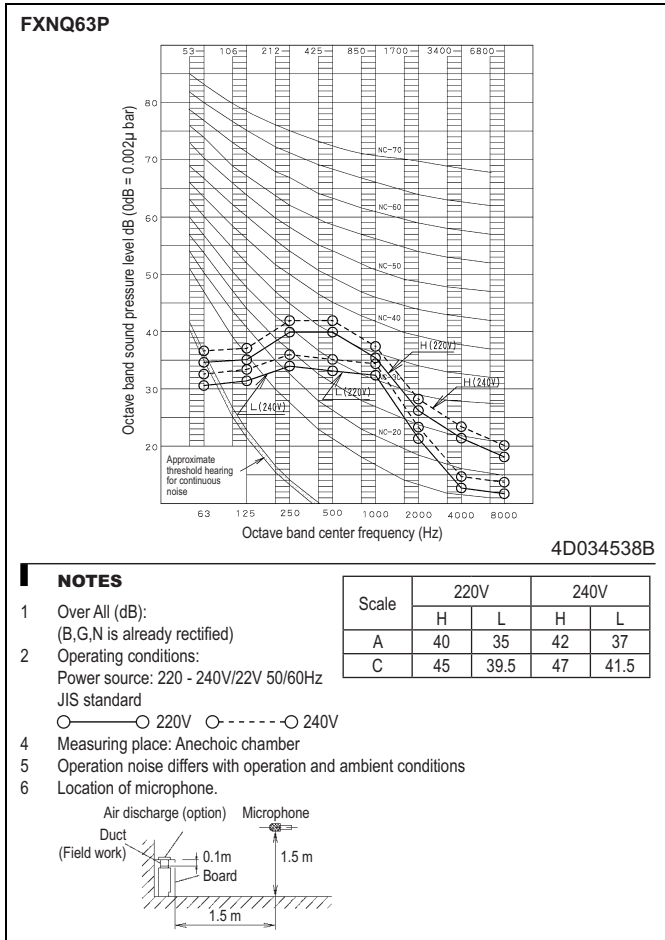

11 Installation

11 - 1 Suspension Bolt Pitch Position

11

FXNQ-P

- Positioning of holes for fastening to the wall

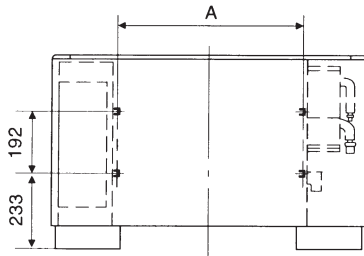

Model	A
FXNQ20,2P	590
FXNQ32,40P	730
FXNQ50,63P	1,010

- How to open/close the front panel

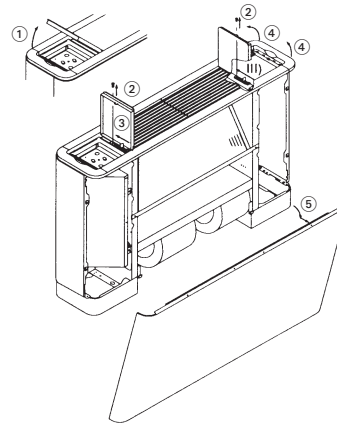

- 1 Open the lid of control panel (both left and right).
- 2 Remove screws (both left and right).
- 3 Push the knobs (both left and right) to the rear.
- 4 Lift the front of the top plate.
- 5 Lower the front panel towards the front of the unit.
- 6 To close, perform the procedure in opposite order. Pull towards the front until the knob snaps in place.

3PN86154-1-5

11 Installation

11 - 2 Service Space

FXNQ-P

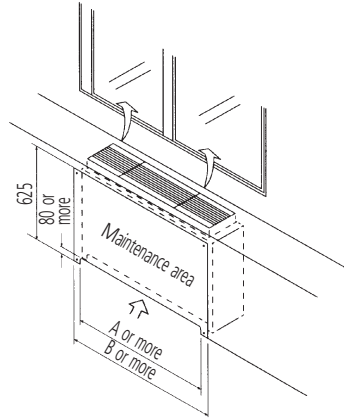

Model	A	B
FXNQ20,2P	570	1,030
FXNQ32,40P	710	1,170
FXNQ50,63P	990	1,450

NOTE

- 1 Leave sufficient clearance for air inlet and maintenance.

3P086154-1-4

In all of us,
a green heart



Daikin's unique position as a manufacturer of air conditioning equipment, compressors and refrigerants has led to its close involvement in environmental issues. For several years Daikin has had the intention to become a leader in the provision of products that have limited impact on the environment. This challenge demands the eco design and development of a wide range of products and an energy management system, resulting in energy conservation and a reduction of waste.



VRV® products are not within the scope of the Eurovent certification programme.

The present publication is drawn up by way of information only and does not constitute an offer binding upon Daikin Europe N.V. Daikin Europe N.V. has compiled the content of this publication to the best of its knowledge. No express or implied warranty is given for the completeness, accuracy, reliability or fitness for particular purpose of its content and the products and services presented therein. Specifications are subject to change without prior notice. Daikin Europe N.V. explicitly rejects any liability for any direct or indirect damage, in the broadest sense, arising from or related to the use and/or interpretation of this publication. All content is copyrighted by Daikin Europe N.V.

Daikin products are distributed by: