



Air Conditioners

Technical Data



VRV®III heat pump, with connection to stylish indoor units



EEDEN11-200

RXYRQ-P



Air Conditioners

Technical Data



VRV®III heat pump, with connection to stylish indoor units



EEDEN11-200

RXYRQ-P

TABLE OF CONTENTS

RXYRQ-P

1	Specifications	2
	Technical Specifications	2
	Electrical Specifications	4
2	Electrical data	5
	Electrical Data	5
3	Options	6
	Options	6
4	Capacity tables	7
	Cooling Capacity Tables	7
	Heating Capacity Tables	67
	Integrated Heating Capacity Correction Factor	79
	Capacity Correction Factor	80
5	Dimensional drawings	85
	Dimensional Drawings	85
	Dimensional Drawings with Accessories	87
6	Centre of gravity	88
	Centre of Gravity	88
7	Piping diagrams	90
	Piping Diagrams	90
8	Wiring diagrams	93
	Wiring Diagrams - Three Phase	93
9	External connection diagrams	96
	External Connection Diagrams	96
10	Sound data	97
	Sound Power Spectrum	97
	Sound Pressure Spectrum	99
11	Installation	101
	Service Space	101
	Fixation and Foundation of Units	102
	Refrigerant Pipe Selection	103
12	Operation range	106
	Operation Range	106

1 Specifications

1-1 Technical Specifications				RXYRQ8P	RXYRQ10P	RXYRQ12P	RXYRQ14P	RXYRQ16P	RXYRQ18P	
Capacity range			HP	8	10	12	14	16	18	
Cooling capacity	Nom.		kW	22.4 (1)	28.0 (1)	33.5 (1)	40.0 (1)	45.0 (1)	49.0 (1)	
	Heating capacity	Nom.	kW	25.0 (2)	31.5 (2)	37.5 (2)	45.0 (2)	50.0 (2)	56.5 (2)	
Capacity control	Method		Inverter controlled							
	Steps		%	~ 100						
Power input - 50Hz	Cooling	Nom.	kW	5.09	7.11	9.23	11.40	13.50	15.30	
	Heating	Nom.	kW	5.56	7.70	9.44	11.30	12.90	15.30	
EER				4.40	3.94	3.63	3.61	3.33	3.20	
COP				4.50	4.09	3.97	3.98	3.88	3.69	
Maximum number of connectable indoor units				17	21	26	30	34	39	
Indoor index connection	Min.			160	200	240	280	320	360	
	Nom.			200	250	300	350	400	450	
	Max.			260	325	390	455	520	585	
Casing	Colour		Daikin White							
	Material		Painted galvanized steel plate							
Dimensions	Unit	Height	mm	1,680						
		Width	mm	930			1,240			
		Depth	mm	765						
	Packed unit	Height	mm	1,855						
		Width	mm	1,055			1,365			
		Depth	mm	860						
Weight	Unit		kg	187	240		316		324	
	Packed unit		kg	217	273		356		364	
Packing	Material		Carton							
	Weight		kg	4.02			6.35			
Packing 2	Material		Wood							
	Weight		kg	20.85			23.55			
Packing 3	Material		Plastic							
	Weight		kg	0.265			0.330			
Heat exchanger	Length		mm	1,778			2,088			
	Rows	Quantity		54						
	Fin pitch		mm	2.00						
	Passes	Quantity		18			21			
	Face area		m ²	2.112			2.481			
	Stages	Quantity		2						
	Empty tubeplate hole	Quantity		0						
	Tube type			ø8 Hi-XSS						
	Fin	Type		Non-symmetric waffle louvre						
		Treatment		Hydrophilic and corrosion resistant						
Fan	Type		Propeller fan							
	Quantity			1			2			
	Air flow rate	Cooling	Nom.	m ³ /min	171	185	196	233		239
		Heating	Nom.	m ³ /min	171	185	196	233		239
	External static pressure	Max.	Pa	78						
	Discharge direction			Vertical						
Fan motor	Quantity			1			2			
	Model			Brushless DC motor						
Fan motor 2	Output		W	750			350		750	
	Output		W	-			350		750	
Sound power level	Cooling	Nom.	dBA	78			80		83	

1 Specifications

1-1 Technical Specifications				RXYRQ8P	RXYRQ10P	RXYRQ12P	RXYRQ14P	RXYRQ16P	RXYRQ18P	
Sound pressure level	Cooling	Nom.	dBA	57	58	60			63	
Compressor	Quantity			1	2		3			
	Model			Inverter						
	Type			Hermetically sealed scroll compressor						
	Speed			rpm	7,980	6,300			7,980	
	Output			W	3,800	1,200	2,800	300	1,400	3,000
	Crankcase heater			W	33					
Compressor 2	Model			-	ON - OFF					
	Type			-	Hermetically sealed scroll compressor					
	Speed			rpm	-	2,900			-	
	Output			W	-	4,500			-	
	Crankcase heater			W	-	33			-	
Compressor 3	Model			-	ON - OFF					
	Type			-	Hermetically sealed scroll compressor					
	Speed			rpm	-	2,900			-	
	Output			W	-	4,500			-	
	Crankcase heater			W	-	33			-	
Operation range	Cooling	Min.~Max.	°CDB	-5.0~43.0						
	Heating	Min.~Max.	°CWB	-20.0~15.0						
Refrigerant	Type			R-410A						
	Charge			kg	7.7	8.4	8.6	11.3	11.5	11.7
	Control			Electronic expansion valve						
	Circuits	Quantity		1						
Refrigerant oil	Type			Synthetic (ether) oil						
	Charged volume			l	3.2	5.1	5.5	7.8		
Piping connections	Liquid	Type		Braze connection						
		OD		mm	9.52		12.7		15.9	
	Gas	Type		Braze connection						
		OD		mm	19.1	22.2	28.6			
	Heat insulation			Both liquid and gas pipes						
	Piping length	BP - IU	Max.	m	15 (7) / 12 (8) / 8 (9)	15 (7) / 12 (8) / 8 (9)	15 (7) / 12 (8) / 8 (9)	15 (7) / 12 (8) / 8 (9)	15 (7) / 12 (8) / 8 (9)	15 (7) / 12 (8) / 8 (9)
		After branch		Max.	m	70 (10)				
	Total piping length	System	Actual	m	250					
	Level difference	OU - IU	Outdoor unit in highest position	m	50					
			Indoor unit in highest position	m	40					
OU - BP		Max.	m	40						
BP - BP		Max.	m	15						
IU - IU		Max.	m	15						
Defrost method				Reversed cycle						
Defrost control				Sensor for outdoor heat exchanger temperature						
Safety devices	Item	01	High pressure switch							
		02	Fan driver overload protector							
		03	Overcurrent relay							
		04	Inverter overload protector							
		05	PC board fuse							
PED	Category			Category II						

Standard Accessories : Connection pipes; Quantity : 4;

Standard Accessories : Operation manual; Quantity : 1;

Standard Accessories : Installation manual; Quantity : 1;

1 Specifications

1-2 Electrical Specifications			RXYRQ8P	RXYRQ10P	RXYRQ12P	RXYRQ14P	RXYRQ16P	RXYRQ18P	
Power supply	Name		W1						
	Phase		3N~						
	Frequency	Hz	50						
	Voltage	V	400						
Voltage range	Min.	%	-10						
	Max.	%	10						
Current	Zmax	Text	-	0.27			0.24		
	Nominal running current (RLA) - 50Hz	Cooling	A	7.5	11.3	14.0	18.4	21.3	24.2
		Heating	A	8.2	11.1	13.8	16.8	19.4	23.0
Current - 50Hz	Starting current (MSC)		A	-	74	75	84	85	
	Minimum Ssc value		kVa	910	838	849	873		878
	Minimum circuit amps (MCA)		A	18.5	21.6	22.7	31.5		32.5
	Maximum fuse amps (MFA)		A	25			40		
	Total overcurrent amps (TOCA)		A	16.5	31.5		46.4		48.3
	Full load amps (FLA)	Total	A	0.7	0.9		1.2		1.4
Wiring connections - 50Hz	For power supply	Quantity	5						
		Remark	Earth wire included						
	For connection with indoor	Quantity	2						
		Remark	F1,F2						
Power supply intake			Both indoor and outdoor unit						

Notes

- (1) Cooling: indoor temp. 27°CDB, 19°CWB; outdoor temp. 35°CDB; equivalent refrigerant piping: 5m; level difference: 0m; indoor unit fan speed: high; 100% SA/RA indoor units connected
- (2) Heating: indoor temp. 20°CDB; outdoor temp. 7°CDB, 6°CWB; equivalent refrigerant piping: 5m; level difference: 0m; indoor unit fan speed: high.
- (3) Sound power level is an absolute value that a sound source generates.
- (4) Sound pressure level is a relative value, depending on the distance and acoustic environment. For more details, please refer to the sound level drawings.
- (5) Sound values are measured in a semi-anechoic room.
- (6) PED unit category: excluded from scope of PED due to article 1, item 3.6 of 97/23/EC
- (7) up to 60 class
- (8) 60 class
- (9) 71 class
- (10) Refer to refrigerant pipe selection or installation manual
- (11) MFA is used to select the circuit breaker and the ground fault circuit interrupter (earth leakage circuit breaker).
- (12) MSC means the maximum current during start up of the compressor
- (13) Maximum allowable voltage range variation between phases is 2%.
- (14) RLA is based on following conditions: indoor temp. 27°CDB, 19°CWB; outdoor temp. 35°CDB
- (15) Select wire size based on the value of MCA
- (16) TOCA means the total value of each OC set.
- (17) Voltage range: units are suitable for use on electrical systems where voltage supplied to unit terminal is not below or above listed range limits.
- (18) In accordance with EN/IEC 61000-3-11, respectively EN/IEC 61000-3-12, it may be necessary to consult the distribution network operator to ensure that the equipment is connected only to a supply with $Z_{sys} \leq Z_{max}$, respectively $S_{sc} \geq$ minimum Ssc value.
- (19) EN/IEC 61000-3-11: European/international technical standard setting the limits for voltage changes, voltage fluctuations and flicker in public low-voltage supply systems for equipment with rated $\leq 75A$
- (20) EN/IEC 61000-3-12: European/international technical standard setting the limits for harmonic currents produced by equipment connected to public low-voltage system with input current $\gt 16A$ and $\leq 75A$ per phase
- (21) Ssc: Short-circuit power
- (22) Zsys: system impedance

2 Electrical data

2 - 1 Electrical Data

RXYRQ-P

	Minimum S_{sc} value [kVA]	Z_{max} [Ω]
RXYRQ8P	910	-
RXYRQ10P	838	0.27
RXYRQ12P	849	0.27
RXYRQ14P	873	0.24
RXYRQ16P	873	0.24
RXYRQ18P	878	0.24

NOTES

- In accordance with EN/IEC 61000-3-11⁽¹⁾, respectively EN/IEC 61000-3-12⁽²⁾, it may be necessary to consult the distribution network operator to ensure that the equipment is connected only to a supply with $Z_{SYS}^{(4)} \leq Z_{MAX}$, respectively $S_{sc}^{(3)} \geq$ minimum S_{sc} value.
- (1) European/international technical standard setting the limits for voltage changes, voltage fluctuations and flicker in public low-voltage supply systems for equipment with rated $\leq 75A$.
 (2) European/international technical standard setting the limits for harmonic currents produced by equipment connected to public low-voltage system with input current $> 16A$ and $\leq 75A$ per phase.
 (3) Short-circuit power
 (4) System impedance

4TW33911-1

3 Options

3 - 1 Options

RXYRQ-P

No	Item	RXYRQ8P RXYRQ10P	RXYRQ12P	RXYRQ14P RXYRQ16P RXYRQ18P
1	Cool/heat selector	KRC19-26A		
2	Fixing box	KJB111A		
3	Refnet header	KHRQ22M29H		
		-	KHRQ22M64H	
4	Refnet joint	KHRQ22M20T		
		KHRQ22M29T9		
		-	KHRQ22M64T	
5	Central drain pan kit	KWC26B280	KWC26B450	
6	Digital pressure gauge kit	BHGP26A1		
7	Branch provider	BPMKS967A2		
		BPMKS967A3		

NOTES

1. All options are kits.

4TW33919-2

4 Capacity tables

4 - 1 Cooling Capacity Tables

RXYRQ8P - Correction factor for mixed connection: 1.0																		
TC: Total Capacity: kW ; PI: Power Input: kW (compressor + outdoor fan motor)																		
Combination (%)	Capacity index (kW)	Outdoor air temp. °CDB	Indoor air temperature:															
			14.0 °CWB		16.0 °CWB		18.0 °CWB		19.0 °CWB		20.0 °CWB		22.0 °CWB		24.0 °CWB			
			20.0 °CDB		23.0 °CDB		16.0 °CDB		27.0 °CDB		28.0 °CDB		30.0 °CDB		32.0 °CDB			
		TC	PI	TC	PI	TC	PI	TC	PI	TC	PI	TC	PI	TC	PI			
130	260 (29.12)	10	19.7	2.34	23.4	2.87	27.2	3.41	28.2	3.48	28.6	3.41	29.3	3.27	30.0	3.12		
		12	19.7	2.39	23.4	2.92	27.2	3.48	27.8	3.47	28.2	3.39	28.9	3.25	29.6	3.20		
		14	19.7	2.43	23.4	2.98	27.1	3.52	27.5	3.45	27.8	3.37	28.5	3.35	29.3	3.38		
		16	19.7	2.48	23.4	3.04	26.8	3.50	27.1	3.48	27.5	3.49	28.2	3.53	28.9	3.56		
		18	19.7	2.53	23.4	3.10	26.4	3.64	26.8	3.66	27.1	3.67	27.8	3.71	28.5	3.74		
		20	19.7	2.58	23.4	3.30	26.0	3.82	26.4	3.83	26.7	3.85	27.5	3.89	28.2	3.93		
		21	19.7	2.65	23.4	3.42	25.9	3.90	26.2	3.92	26.6	3.94	27.3	3.98	28.0	4.02		
		23	19.7	2.84	23.4	3.66	25.5	4.08	25.8	4.10	26.2	4.12	26.9	4.17	27.6	4.21		
		25	19.7	3.03	23.4	3.92	25.1	4.26	25.5	4.28	25.8	4.30	26.5	4.35	27.3	4.39		
		27	19.7	3.24	23.4	4.20	24.8	4.44	25.1	4.46	25.5	4.49	26.2	4.53	26.9	4.58		
		29	19.7	3.46	23.4	4.49	24.4	4.62	24.8	4.64	25.1	4.67	25.8	4.72	26.5	4.77		
		31	19.7	3.69	23.3	4.75	24.0	4.80	24.4	4.83	24.7	4.85	25.4	4.91	26.2	4.96		
		33	19.7	3.93	23.0	4.93	23.7	4.98	24.0	5.01	24.4	5.04	25.1	5.09	25.8	5.15		
		35	19.7	4.19	22.6	5.11	23.3	5.16	23.7	5.19	24.0	5.22	24.7	5.28	25.4	5.34		
		37	19.7	4.46	22.2	5.29	22.9	5.35	23.3	5.38	23.6	5.41	24.4	5.47	25.1	5.53		
		39	19.7	4.75	21.9	5.47	22.6	5.53	22.9	5.56	23.3	5.60	24.0	5.66	24.7	5.73		
		120	240 (26.88)	10	18.1	2.14	21.6	2.62	25.1	3.11	26.9	3.36	28.1	3.50	28.8	3.37	29.4	3.24
				12	18.1	2.18	21.6	2.66	25.1	3.17	26.9	3.43	27.8	3.48	28.4	3.35	29.1	3.22
14	18.1			2.22	21.6	2.72	25.1	3.23	26.9	3.49	27.4	3.47	28.0	3.33	28.7	3.35		
16	18.1			2.26	21.6	2.77	25.1	3.29	26.7	3.52	27.0	3.47	27.7	3.50	28.3	3.54		
18	18.1			2.31	21.6	2.82	25.1	3.41	26.3	3.63	26.7	3.65	27.3	3.68	28.0	3.72		
20	18.1			2.35	21.6	2.94	25.1	3.66	26.0	3.81	26.3	3.83	27.0	3.86	27.6	3.90		
21	18.1			2.38	21.6	3.04	25.1	3.79	25.8	3.90	26.1	3.92	26.8	3.95	27.4	3.99		
23	18.1			2.54	21.6	3.26	25.1	4.06	25.4	4.08	25.8	4.10	26.4	4.14	27.1	4.17		
25	18.1			2.71	21.6	3.49	24.7	4.24	25.1	4.26	25.4	4.28	26.0	4.32	26.7	4.36		
27	18.1			2.89	21.6	3.73	24.4	4.41	24.7	4.44	25.0	4.46	25.7	4.50	26.3	4.54		
29	18.1			3.09	21.6	3.98	24.0	4.59	24.3	4.62	24.7	4.64	25.3	4.68	26.0	4.73		
31	18.1			3.29	21.6	4.25	23.6	4.77	24.0	4.80	24.3	4.82	24.9	4.87	25.6	4.92		
33	18.1			3.50	21.6	4.53	23.3	4.95	23.6	4.98	23.9	5.00	24.6	5.05	25.2	5.10		
35	18.1			3.73	21.6	4.83	22.9	5.13	23.2	5.16	23.6	5.19	24.2	5.24	24.9	5.29		
37	18.1			3.97	21.6	5.15	22.5	5.31	22.9	5.34	23.2	5.37	23.9	5.43	24.5	5.48		
39	18.1			4.22	21.5	5.44	22.2	5.50	22.5	5.53	22.8	5.56	23.5	5.62	24.1	5.68		
110	220 (24.64)			10	16.6	1.94	19.8	2.37	23.0	2.81	24.6	3.04	26.2	3.27	28.3	3.47	28.9	3.35
				12	16.6	1.98	19.8	2.41	23.0	2.87	24.6	3.10	26.2	3.33	27.9	3.45	28.5	3.33
		14	16.6	2.02	19.8	2.46	23.0	2.92	24.6	3.16	26.2	3.40	27.5	3.44	28.1	3.33		
		16	16.6	2.05	19.8	2.50	23.0	2.98	24.6	3.22	26.2	3.46	27.2	3.48	27.8	3.51		
		18	16.6	2.09	19.8	2.55	23.0	3.04	24.6	3.31	26.2	3.63	26.8	3.66	27.4	3.69		
		20	16.6	2.13	19.8	2.61	23.0	3.22	24.6	3.55	25.9	3.81	26.5	3.84	27.1	3.87		
		21	16.6	2.15	19.8	2.68	23.0	3.33	24.6	3.68	25.7	3.89	26.3	3.93	26.9	3.96		
		23	16.6	2.25	19.8	2.87	23.0	3.57	24.6	3.95	25.3	4.07	25.9	4.11	26.5	4.14		
		25	16.6	2.41	19.8	3.07	23.0	3.82	24.6	4.23	24.9	4.25	25.5	4.29	26.1	4.32		
		27	16.6	2.57	19.8	3.28	23.0	4.09	24.3	4.41	24.6	4.43	25.2	4.47	25.8	4.51		
		29	16.6	2.74	19.8	3.51	23.0	4.37	23.9	4.59	24.2	4.61	24.8	4.65	25.4	4.69		
		31	16.6	2.92	19.8	3.74	23.0	4.67	23.5	4.76	23.8	4.79	24.4	4.83	25.0	4.88		
		33	16.6	3.10	19.8	3.98	22.9	4.92	23.2	4.94	23.5	4.97	24.1	5.01	24.7	5.06		
		35	16.6	3.30	19.8	4.25	22.5	5.10	22.8	5.12	23.1	5.15	23.7	5.20	24.3	5.25		
		37	16.6	3.51	19.8	4.52	22.2	5.28	22.5	5.31	22.8	5.33	23.4	5.38	24.0	5.44		
		39	16.6	3.73	19.8	4.81	21.8	5.46	22.1	5.49	22.4	5.52	23.0	5.57	23.6	5.63		
		100	200 (22.40)	10	15.1	1.75	18.0	2.13	20.9	2.52	22.4	2.72	23.9	2.93	26.8	3.35	28.3	3.46
				12	15.1	1.78	18.0	2.17	20.9	2.57	22.4	2.77	23.9	2.98	26.8	3.41	28.0	3.44
14	15.1			1.82	18.0	2.21	20.9	2.62	22.4	2.83	23.9	3.04	26.8	3.47	27.6	3.43		
16	15.1			1.85	18.0	2.25	20.9	2.67	22.4	2.88	23.9	3.10	26.7	3.52	27.2	3.48		
18	15.1			1.88	18.0	2.29	20.9	2.72	22.4	2.94	23.9	3.16	26.3	3.63	26.9	3.66		
20	15.1			1.92	18.0	2.34	20.9	2.80	22.4	3.09	23.9	3.39	26.0	3.81	26.5	3.84		
21	15.1			1.94	18.0	2.36	20.9	2.90	22.4	3.20	23.9	3.51	25.8	3.90	26.3	3.93		
23	15.1			1.99	18.0	2.52	20.9	3.11	22.4	3.43	23.9	3.76	25.4	4.08	25.9	4.11		
25	15.1			2.12	18.0	2.69	20.9	3.32	22.4	3.67	23.9	4.03	25.0	4.26	25.6	4.29		
27	15.1			2.26	18.0	2.87	20.9	3.55	22.4	3.92	23.9	4.31	24.7	4.43	25.2	4.47		
29	15.1			2.41	18.0	3.06	20.9	3.79	22.4	4.19	23.8	4.58	24.3	4.61	24.9	4.65		
31	15.1			2.56	18.0	3.26	20.9	4.05	22.4	4.47	23.4	4.75	23.9	4.79	24.5	4.83		
33	15.1			2.73	18.0	3.47	20.9	4.32	22.4	4.77	23.0	4.93	23.6	4.98	24.1	5.02		
35	15.1			2.90	18.0	3.70	20.9	4.60	22.4	5.09	22.7	5.11	23.2	5.16	23.8	5.20		
37	15.1			3.08	18.0	3.94	20.9	4.90	22.0	5.27	22.3	5.29	22.9	5.34	23.4	5.39		
39	15.1			3.27	18.0	4.19	20.9	5.22	21.7	5.45	21.9	5.47	22.5	5.52	23.0	5.57		

4TW33912-3A(1)

4 Capacity tables

4 - 1 Cooling Capacity Tables

RXYRQ8P - Correction factor for mixed connection: 1.0

TC: Total Capacity: kW ; PI: Power Input: kW (compressor + outdoor fan motor)

Combination (%)	Capacity index (kW)	Outdoor air temp. °CDB	Indoor air temperature:													
			14.0 °CWB		16.0 °CWB		18.0 °CWB		19.0 °CWB		20.0 °CWB		22.0 °CWB		24.0 °CWB	
			TC	PI	TC	PI	TC	PI	TC	PI	TC	PI	TC	PI	TC	PI
90	180 (20.16)	10	13.6	1.57	16.2	1.89	18.8	2.24	20.2	2.41	21.5	2.59	24.1	2.96	26.7	3.34
		12	13.6	1.60	16.2	1.93	18.8	2.28	20.2	2.46	21.5	2.64	24.1	3.02	26.7	3.40
		14	13.6	1.62	16.2	1.96	18.8	2.32	20.2	2.50	21.5	2.69	24.1	3.08	26.7	3.47
		16	13.6	1.65	16.2	2.00	18.8	2.36	20.2	2.55	21.5	2.74	24.1	3.14	26.7	3.52
		18	13.6	1.68	16.2	2.04	18.8	2.41	20.2	2.60	21.5	2.80	24.1	3.20	26.3	3.63
		20	13.6	1.71	16.2	2.08	18.8	2.46	20.2	2.65	21.5	2.90	24.1	3.44	25.9	3.81
		21	13.6	1.73	16.2	2.10	18.8	2.50	20.2	2.75	21.5	3.01	24.1	3.56	25.8	3.90
		23	13.6	1.76	16.2	2.18	18.8	2.68	20.2	2.94	21.5	3.22	24.1	3.82	25.4	4.08
		25	13.6	1.86	16.2	2.33	18.8	2.86	20.2	3.15	21.5	3.45	24.1	4.09	25.0	4.25
		27	13.6	1.98	16.2	2.49	18.8	3.05	20.2	3.36	21.5	3.68	24.1	4.37	24.7	4.43
		29	13.6	2.10	16.2	2.65	18.8	3.26	20.2	3.59	21.5	3.93	23.8	4.58	24.3	4.61
		31	13.6	2.24	16.2	2.82	18.8	3.47	20.2	3.83	21.5	4.20	23.4	4.76	23.9	4.79
		33	13.6	2.37	16.2	3.00	18.8	3.70	20.2	4.08	21.5	4.48	23.1	4.94	23.6	4.97
		35	13.6	2.52	16.2	3.19	18.8	3.94	20.2	4.35	21.5	4.78	22.7	5.12	23.2	5.16
		37	13.6	2.68	16.2	3.39	18.8	4.20	20.2	4.63	21.5	5.09	22.4	5.30	22.8	5.34
		39	13.6	2.84	16.2	3.61	18.8	4.47	20.2	4.93	21.5	5.42	22.0	5.48	22.5	5.52
		80	160 (17.92)	10	12.1	1.39	14.4	1.67	16.8	1.96	17.9	2.11	19.1	2.27	21.4	2.59
12	12.1			1.42	14.4	1.70	16.8	2.00	17.9	2.15	19.1	2.31	21.4	2.63	23.7	2.97
14	12.1			1.44	14.4	1.73	16.8	2.03	17.9	2.19	19.1	2.35	21.4	2.68	23.7	3.02
16	12.1			1.46	14.4	1.76	16.8	2.07	17.9	2.23	19.1	2.40	21.4	2.74	23.7	3.08
18	12.1			1.49	14.4	1.79	16.8	2.11	17.9	2.28	19.1	2.44	21.4	2.79	23.7	3.14
20	12.1			1.52	14.4	1.82	16.8	2.15	17.9	2.32	19.1	2.49	21.4	2.89	23.7	3.36
21	12.1			1.53	14.4	1.84	16.8	2.17	17.9	2.34	19.1	2.54	21.4	3.00	23.7	3.48
23	12.1			1.56	14.4	1.88	16.8	2.28	17.9	2.49	19.1	2.72	21.4	3.21	23.7	3.74
25	12.1			1.61	14.4	2.00	16.8	2.43	17.9	2.67	19.1	2.91	21.4	3.43	23.7	4.00
27	12.1			1.71	14.4	2.13	16.8	2.59	17.9	2.85	19.1	3.11	21.4	3.67	23.7	4.28
29	12.1			1.82	14.4	2.27	16.8	2.77	17.9	3.03	19.1	3.32	21.4	3.92	23.7	4.57
31	12.1			1.93	14.4	2.41	16.8	2.95	17.9	3.23	19.1	3.54	21.4	4.18	23.4	4.75
33	12.1			2.05	14.4	2.56	16.8	3.14	17.9	3.44	19.1	3.77	21.4	4.46	23.0	4.93
35	12.1			2.17	14.4	2.72	16.8	3.34	17.9	3.67	19.1	4.01	21.4	4.76	22.7	5.11
37	12.1			2.30	14.4	2.89	16.8	3.55	17.9	3.90	19.1	4.27	21.4	5.07	22.3	5.29
39	12.1			2.44	14.4	3.07	16.8	3.77	17.9	4.15	19.1	4.55	21.4	5.40	21.9	5.47

4TW33912-3A(2)

NOTES - ANMERKUNGEN - Σημειώσεις - NOTAS - REMARQUES - NOTE - OPMERKINGEN - Примечания - NOTLAR

- The above table shows the average value of conditions which may occur.
Die obige Tabelle zeigt den Durchschnittswert der Bedingungen, die auftreten können.
Στον παραπάνω πίνακα αναγράφεται η μέση τιμή για συνθήκες που μπορεί να προκύψουν.
La tabla de arriba muestra el valor medio de condiciones que pueden ocurrir.
Le tableau ci-dessus donne la valeur moyenne pour des conditions qui peuvent survenir.
La tabella in alto mostra il valore delle condizioni medie che si possono riscontrare.
De tabel hierboven geeft de gemiddelde waarde aan van situaties die kunnen voorvallen.
Таблица расположенная выше показывает среднее значение условий, которые могут наступить.
Yukarıdaki tablo meydana gelebilecek koşulların ortalama değerini göstermektedir.
- Correction factor for mixed connection: 1.0. For more information refer to the selection procedure.
Korrekturfaktoren für gemischten Anschluss: 1,0. Weitere Informationen finden Sie im Auswahlverfahren.
Συντελεστής διόρθωσης για συνδυαζόμενη σύνδεση: 1,0. Για περισσότερες πληροφορίες ανατρέξτε στη διαδικασία επιλογής.
Factor de corrección para conexión combinada: 1,0. Si desea más información, consulte el procedimiento de selección.
Facteur de correction pour connexion d'unités mixtes : 1,0. Pour plus d'informations, se reporter à la procédure de sélection.
Fattore di correzione per collegamento varie unità: 1,0. Per maggiori informazioni fare riferimento alla procedura di selezione.
Correctiefactor voor gemengde aansluiting: 1,0. Zie selectieprocedure voor meer informatie.
Поправочный коэффициент для комбинированного соединения: 1,0. Подробная информация приводится в разделе порядка выбора.
Karışık bağlantı için düzeltme faktörü: 1.0. Daha fazla bilgi için, seçim prosedürüne bakın.

4 Capacity tables

4 - 1 Cooling Capacity Tables

RXYRQ8P - Correction factor for mixed connection: 0.9																		
TC: Total Capacity: kW ; PI: Power Input: kW (compressor + outdoor fan motor)																		
Combination (%)	Capacity index (kW)	Outdoor air temp.	Indoor air temperature:															
			14.0 °CWB		16.0 °CWB		18.0 °CWB		19.0 °CWB		20.0 °CWB		22.0 °CWB		24.0 °CWB			
			20.0 °CDB		23.0 °CDB		16.0 °CDB		27.0 °CDB		28.0 °CDB		30.0 °CDB		32.0 °CDB			
		°CDB	TC	PI	TC	PI	TC	PI	TC	PI	TC	PI	TC	PI	TC	PI		
130	260 (29.12)	10	17.7	2.04	21.1	2.47	24.5	2.92	26.2	3.15	27.9	3.37	29.3	3.27	30.0	3.12		
		12	17.7	2.07	21.1	2.52	24.5	2.97	26.2	3.20	27.9	3.39	28.9	3.25	29.6	3.20		
		14	17.7	2.11	21.1	2.56	24.5	3.03	26.2	3.26	27.8	3.37	28.5	3.35	29.3	3.38		
		16	17.7	2.15	21.1	2.61	24.5	3.08	26.2	3.37	27.5	3.49	28.2	3.53	28.9	3.56		
		18	17.7	2.19	21.1	2.66	24.5	3.28	26.2	3.63	27.1	3.67	27.8	3.71	28.5	3.74		
		20	17.7	2.23	21.1	2.83	24.5	3.52	26.2	3.83	26.7	3.85	27.5	3.89	28.2	3.93		
		21	17.7	2.29	21.1	2.93	24.5	3.65	26.2	3.92	26.6	3.94	27.3	3.98	28.0	4.02		
		23	17.7	2.45	21.1	3.14	24.5	3.92	25.8	4.10	26.2	4.12	26.9	4.17	27.6	4.21		
		25	17.7	2.62	21.1	3.36	24.5	4.19	25.5	4.28	25.8	4.30	26.5	4.35	27.3	4.39		
		27	17.7	2.79	21.1	3.59	24.5	4.44	25.1	4.46	25.5	4.49	26.2	4.53	26.9	4.58		
		29	17.7	2.98	21.1	3.83	24.4	4.62	24.8	4.64	25.1	4.67	25.8	4.72	26.5	4.77		
		31	17.7	3.18	21.1	4.09	24.0	4.80	24.4	4.83	24.7	4.85	25.4	4.91	26.2	4.96		
		33	17.7	3.38	21.1	4.36	23.7	4.98	24.0	5.01	24.4	5.04	25.1	5.09	25.8	5.15		
		35	17.7	3.60	21.1	4.65	23.3	5.16	23.7	5.19	24.0	5.22	24.7	5.28	25.4	5.34		
		37	17.7	3.83	21.1	4.96	22.9	5.35	23.3	5.38	23.6	5.41	24.4	5.47	25.1	5.53		
		39	17.7	4.07	21.1	5.28	22.6	5.53	22.9	5.56	23.3	5.60	24.0	5.66	24.7	5.73		
		120	240 (26.88)	10	16.3	1.87	19.5	2.26	22.6	2.67	24.2	2.88	25.8	3.09	28.8	3.37	29.4	3.24
				12	16.3	1.90	19.5	2.30	22.6	2.72	24.2	2.93	25.8	3.14	28.4	3.35	29.1	3.22
14	16.3			1.93	19.5	2.34	22.6	2.77	24.2	2.98	25.8	3.20	28.0	3.33	28.7	3.35		
16	16.3			1.97	19.5	2.39	22.6	2.82	24.2	3.04	25.8	3.28	27.7	3.50	28.3	3.54		
18	16.3			2.00	19.5	2.43	22.6	2.91	24.2	3.22	25.8	3.54	27.3	3.68	28.0	3.72		
20	16.3			2.04	19.5	2.53	22.6	3.13	24.2	3.46	25.8	3.80	27.0	3.86	27.6	3.90		
21	16.3			2.06	19.5	2.62	22.6	3.24	24.2	3.58	25.8	3.92	26.8	3.95	27.4	3.99		
23	16.3			2.20	19.5	2.80	22.6	3.48	24.2	3.84	25.8	4.10	26.4	4.14	27.1	4.17		
25	16.3			2.35	19.5	2.99	22.6	3.72	24.2	4.11	25.4	4.28	26.0	4.32	26.7	4.36		
27	16.3			2.51	19.5	3.20	22.6	3.98	24.2	4.40	25.0	4.46	25.7	4.50	26.3	4.54		
29	16.3			2.67	19.5	3.41	22.6	4.25	24.2	4.62	24.7	4.64	25.3	4.68	26.0	4.73		
31	16.3			2.84	19.5	3.64	22.6	4.54	24.0	4.80	24.3	4.82	24.9	4.87	25.6	4.92		
33	16.3			3.03	19.5	3.88	22.6	4.84	23.6	4.98	23.9	5.00	24.6	5.05	25.2	5.10		
35	16.3			3.22	19.5	4.13	22.6	5.13	23.2	5.16	23.6	5.19	24.2	5.24	24.9	5.29		
37	16.3			3.42	19.5	4.40	22.5	5.31	22.9	5.34	23.2	5.37	23.9	5.43	24.5	5.48		
39	16.3			3.64	19.5	4.68	22.2	5.50	22.5	5.53	22.8	5.56	23.5	5.62	24.1	5.68		
110	220 (24.64)			10	15.0	1.70	17.9	2.06	20.7	2.42	22.2	2.61	23.6	2.80	26.5	3.18	28.9	3.35
				12	15.0	1.73	17.9	2.09	20.7	2.47	22.2	2.66	23.6	2.85	26.5	3.24	28.5	3.33
		14	15.0	1.76	17.9	2.13	20.7	2.51	22.2	2.71	23.6	2.91	26.5	3.30	28.1	3.33		
		16	15.0	1.79	17.9	2.17	20.7	2.56	22.2	2.76	23.6	2.96	26.5	3.43	27.8	3.51		
		18	15.0	1.83	17.9	2.21	20.7	2.61	22.2	2.83	23.6	3.11	26.5	3.66	27.4	3.69		
		20	15.0	1.86	17.9	2.25	20.7	2.76	22.2	3.04	23.6	3.34	26.5	3.84	27.1	3.87		
		21	15.0	1.88	17.9	2.32	20.7	2.86	22.2	3.15	23.6	3.46	26.3	3.93	26.9	3.96		
		23	15.0	1.96	17.9	2.48	20.7	3.06	22.2	3.38	23.6	3.71	25.9	4.11	26.5	4.14		
		25	15.0	2.10	17.9	2.65	20.7	3.28	22.2	3.61	23.6	3.97	25.5	4.29	26.1	4.32		
		27	15.0	2.23	17.9	2.83	20.7	3.50	22.2	3.86	23.6	4.25	25.2	4.47	25.8	4.51		
		29	15.0	2.38	17.9	3.02	20.7	3.74	22.2	4.13	23.6	4.54	24.8	4.65	25.4	4.69		
		31	15.0	2.53	17.9	3.22	20.7	3.99	22.2	4.41	23.6	4.79	24.4	4.83	25.0	4.88		
		33	15.0	2.69	17.9	3.43	20.7	4.25	22.2	4.70	23.5	4.97	24.1	5.01	24.7	5.06		
		35	15.0	2.86	17.9	3.65	20.7	4.53	22.2	5.01	23.1	5.15	23.7	5.20	24.3	5.25		
		37	15.0	3.04	17.9	3.88	20.7	4.83	22.2	5.31	22.8	5.33	23.4	5.38	24.0	5.44		
		39	15.0	3.22	17.9	4.13	20.7	5.14	22.1	5.49	22.4	5.52	23.0	5.57	23.6	5.63		
		100	200 (22.40)	10	13.6	1.54	16.2	1.86	18.8	2.18	20.2	2.35	21.5	2.52	24.1	2.86	26.7	3.21
				12	13.6	1.57	16.2	1.89	18.8	2.22	20.2	2.39	21.5	2.56	24.1	2.92	26.7	3.27
14	13.6			1.60	16.2	1.92	18.8	2.26	20.2	2.44	21.5	2.61	24.1	2.97	26.7	3.33		
16	13.6			1.62	16.2	1.96	18.8	2.30	20.2	2.48	21.5	2.66	24.1	3.03	26.7	3.47		
18	13.6			1.65	16.2	1.99	18.8	2.35	20.2	2.53	21.5	2.71	24.1	3.20	26.7	3.66		
20	13.6			1.68	16.2	2.03	18.8	2.42	20.2	2.65	21.5	2.90	24.1	3.44	26.5	3.84		
21	13.6			1.70	16.2	2.05	18.8	2.50	20.2	2.75	21.5	3.01	24.1	3.56	26.3	3.93		
23	13.6			1.74	16.2	2.18	18.8	2.68	20.2	2.94	21.5	3.22	24.1	3.82	25.9	4.11		
25	13.6			1.86	16.2	2.33	18.8	2.86	20.2	3.15	21.5	3.45	24.1	4.09	25.6	4.29		
27	13.6			1.98	16.2	2.49	18.8	3.05	20.2	3.36	21.5	3.68	24.1	4.37	25.2	4.47		
29	13.6			2.10	16.2	2.65	18.8	3.26	20.2	3.59	21.5	3.93	24.1	4.61	24.9	4.65		
31	13.6			2.24	16.2	2.82	18.8	3.47	20.2	3.83	21.5	4.20	23.9	4.79	24.5	4.83		
33	13.6			2.37	16.2	3.00	18.8	3.70	20.2	4.08	21.5	4.48	23.6	4.98	24.1	5.02		
35	13.6			2.52	16.2	3.19	18.8	3.94	20.2	4.35	21.5	4.78	23.2	5.16	23.8	5.20		
37	13.6			2.68	16.2	3.39	18.8	4.20	20.2	4.63	21.5	5.09	22.9	5.34	23.4	5.39		
39	13.6			2.84	16.2	3.61	18.8	4.47	20.2	4.93	21.5	5.42	22.5	5.52	23.0	5.57		

4TW33912-3A(3)

4 Capacity tables

4 - 1 Cooling Capacity Tables

RXYRQ8P - Correction factor for mixed connection: 0.9

TC: Total Capacity: kW ; PI: Power Input: kW (compressor + outdoor fan motor)

Combination (%)	Capacity index (kW)	Outdoor air temp. °CDB	Indoor air temperature:													
			14.0 °CWB		16.0 °CWB		18.0 °CWB		19.0 °CWB		20.0 °CWB		22.0 °CWB		24.0 °CWB	
			TC	PI	TC	PI	TC	PI	TC	PI	TC	PI	TC	PI	TC	PI
90 (20.16)	180	10	12.2	1.39	14.6	1.66	17.0	1.95	18.1	2.09	19.3	2.24	21.7	2.55	24.0	2.86
		12	12.2	1.41	14.6	1.69	17.0	1.98	18.1	2.13	19.3	2.28	21.7	2.59	24.0	2.91
		14	12.2	1.44	14.6	1.72	17.0	2.02	18.1	2.17	19.3	2.32	21.7	2.64	24.0	2.96
		16	12.2	1.46	14.6	1.75	17.0	2.05	18.1	2.21	19.3	2.37	21.7	2.69	24.0	3.02
		18	12.2	1.48	14.6	1.78	17.0	2.09	18.1	2.25	19.3	2.41	21.7	2.74	24.0	3.19
		20	12.2	1.51	14.6	1.81	17.0	2.13	18.1	2.29	19.3	2.50	21.7	2.94	24.0	3.43
		21	12.2	1.52	14.6	1.83	17.0	2.17	18.1	2.37	19.3	2.59	21.7	3.05	24.0	3.55
		23	12.2	1.55	14.6	1.90	17.0	2.32	18.1	2.54	19.3	2.77	21.7	3.27	24.0	3.81
		25	12.2	1.63	14.6	2.03	17.0	2.47	18.1	2.71	19.3	2.96	21.7	3.50	24.0	4.08
		27	12.2	1.74	14.6	2.16	17.0	2.64	18.1	2.90	19.3	3.16	21.7	3.74	24.0	4.36
		29	12.2	1.85	14.6	2.30	17.0	2.81	18.1	3.09	19.3	3.38	21.7	3.99	24.0	4.61
		31	12.2	1.96	14.6	2.45	17.0	3.00	18.1	3.29	19.3	3.60	21.7	4.26	23.9	4.79
		33	12.2	2.08	14.6	2.60	17.0	3.19	18.1	3.51	19.3	3.84	21.7	4.55	23.6	4.97
		35	12.2	2.21	14.6	2.77	17.0	3.39	18.1	3.73	19.3	4.09	21.7	4.85	23.2	5.16
		37	12.2	2.34	14.6	2.94	17.0	3.61	18.1	3.97	19.3	4.35	21.7	5.16	22.8	5.34
		39	12.2	2.48	14.6	3.12	17.0	3.84	18.1	4.23	19.3	4.63	21.7	5.48	22.5	5.52
80 (17.92)	160	10	10.9	1.24	13.0	1.47	15.1	1.72	16.1	1.84	17.2	1.97	19.3	2.24	21.4	2.51
		12	10.9	1.26	13.0	1.50	15.1	1.75	16.1	1.88	17.2	2.01	19.3	2.28	21.4	2.55
		14	10.9	1.28	13.0	1.52	15.1	1.78	16.1	1.91	17.2	2.04	19.3	2.32	21.4	2.60
		16	10.9	1.30	13.0	1.55	15.1	1.81	16.1	1.94	17.2	2.08	19.3	2.36	21.4	2.65
		18	10.9	1.32	13.0	1.57	15.1	1.84	16.1	1.98	17.2	2.12	19.3	2.41	21.4	2.70
		20	10.9	1.34	13.0	1.60	15.1	1.88	16.1	2.02	17.2	2.16	19.3	2.49	21.4	2.88
		21	10.9	1.36	13.0	1.62	15.1	1.89	16.1	2.03	17.2	2.20	19.3	2.58	21.4	2.99
		23	10.9	1.38	13.0	1.65	15.1	1.98	16.1	2.16	17.2	2.36	19.3	2.76	21.4	3.20
		25	10.9	1.42	13.0	1.75	15.1	2.12	16.1	2.31	17.2	2.52	19.3	2.95	21.4	3.42
		27	10.9	1.51	13.0	1.86	15.1	2.25	16.1	2.46	17.2	2.68	19.3	3.15	21.4	3.66
		29	10.9	1.61	13.0	1.98	15.1	2.40	16.1	2.63	17.2	2.86	19.3	3.36	21.4	3.91
		31	10.9	1.70	13.0	2.11	15.1	2.55	16.1	2.80	17.2	3.05	19.3	3.59	21.4	4.17
		33	10.9	1.81	13.0	2.24	15.1	2.72	16.1	2.98	17.2	3.25	19.3	3.82	21.4	4.45
		35	10.9	1.91	13.0	2.37	15.1	2.89	16.1	3.16	17.2	3.45	19.3	4.07	21.4	4.74
		37	10.9	2.02	13.0	2.52	15.1	3.07	16.1	3.36	17.2	3.67	19.3	4.34	21.4	5.05
		39	10.9	2.14	13.0	2.67	15.1	3.26	16.1	3.57	17.2	3.91	19.3	4.61	21.4	5.38

4TW33912-3A(4)

NOTES - ANMERKUNGEN - Σημειώσεις - NOTAS - REMARQUES - NOTE - OPMERKINGEN - Примечания - NOTLAR

- The above table shows the average value of conditions which may occur.
Die obige Tabelle zeigt den Durchschnittswert der Bedingungen, die auftreten können.
Στον παραπάνω πίνακα αναγράφεται η μέση τιμή για συνθήκες που μπορεί να προκύψουν.
La tabla de arriba muestra el valor medio de condiciones que pueden ocurrir.
Le tableau ci-dessus donne la valeur moyenne pour des conditions qui peuvent survenir.
La tabella in alto mostra il valore delle condizioni medie che si possono riscontrare.
De tabel hierboven geeft de gemiddelde waarde aan van situaties die kunnen voorvallen.
Таблица расположенная выше показывает среднее значение условий, которые могут наступить.
Yukarıdaki tablo meydana gelebilecek koşulların ortalama değerini göstermektedir.
- Correction factor for mixed connection: 0.9. For more information refer to the selection procedure.
Korrekturfaktoren für gemischten Anschluss: 0,9. Weitere Informationen finden Sie im Auswahlverfahren.
Συντελεστής διόρθωσης για συνδυαζόμενη σύνδεση: 0,9. Για περισσότερες πληροφορίες ανατρέξτε στη διαδικασία επιλογής.
Factor de corrección para conexión combinada: 0,9. Si desea más información, consulte el procedimiento de selección.
Facteur de correction pour connexion d'unités mixtes : 0,9. Pour plus d'informations, se reporter à la procédure de sélection.
Fattore di correzione per collegamento varie unità: 0,9. Per maggiori informazioni fare riferimento alla procedura di selezione.
Correctiefactor voor gemengde aansluiting: 0,9. Zie selectieprocedure voor meer informatie.
Поправочный коэффициент для комбинированного соединения: 0,9. Подробная информация приводится в разделе порядка выбора.
Karışık bağlantı için düzeltme faktörü: 0.9. Daha fazla bilgi için, seçim prosedürüne bakın.

4 Capacity tables

4 - 1 Cooling Capacity Tables

RXYRQ8P - Correction factor for mixed connection: 0.8																		
TC: Total Capacity: kW ; PI: Power Input: kW (compressor + outdoor fan motor)																		
Combination (%)	Capacity index (kW)	Outdoor air temp. °CDB	Indoor air temperature:															
			14.0 °CWB		16.0 °CWB		18.0 °CWB		19.0 °CWB		20.0 °CWB		22.0 °CWB		24.0 °CWB			
			20.0 °CDB		23.0 °CDB		16.0 °CDB		27.0 °CDB		28.0 °CDB		30.0 °CDB		32.0 °CDB			
			TC	PI	TC	PI	TC	PI	TC	PI	TC	PI	TC	PI	TC	PI		
130	260 (29.12)	10	15.7	1.75	18.8	2.10	21.8	2.46	23.3	2.65	24.8	2.83	27.8	3.19	30.0	3.12		
		12	15.7	1.78	18.8	2.14	21.8	2.51	23.3	2.69	24.8	2.88	27.8	3.24	29.6	3.20		
		14	15.7	1.81	18.8	2.18	21.8	2.55	23.3	2.74	24.8	2.93	27.8	3.35	29.3	3.38		
		16	15.7	1.84	18.8	2.21	21.8	2.60	23.3	2.83	24.8	3.10	27.8	3.53	28.9	3.56		
		18	15.7	1.87	18.8	2.26	21.8	2.76	23.3	3.04	24.8	3.34	27.8	3.71	28.5	3.74		
		20	15.7	1.91	18.8	2.40	21.8	2.96	23.3	3.27	24.8	3.59	27.5	3.89	28.2	3.93		
		21	15.7	1.96	18.8	2.48	21.8	3.07	23.3	3.39	24.8	3.72	27.3	3.98	28.0	4.02		
		23	15.7	2.09	18.8	2.66	21.8	3.29	23.3	3.63	24.8	3.99	26.9	4.17	27.6	4.21		
		25	15.7	2.23	18.8	2.84	21.8	3.52	23.3	3.89	24.8	4.27	26.5	4.35	27.3	4.39		
		27	15.7	2.38	18.8	3.03	21.8	3.76	23.3	4.16	24.8	4.49	26.2	4.53	26.9	4.58		
		29	15.7	2.54	18.8	3.23	21.8	4.02	23.3	4.44	24.8	4.67	25.8	4.72	26.5	4.77		
		31	15.7	2.70	18.8	3.45	21.8	4.29	23.3	4.75	24.7	4.85	25.4	4.91	26.2	4.96		
		33	15.7	2.87	18.8	3.67	21.8	4.58	23.3	5.01	24.4	5.04	25.1	5.09	25.8	5.15		
		35	15.7	3.06	18.8	3.91	21.8	4.88	23.3	5.19	24.0	5.22	24.7	5.28	25.4	5.34		
		37	15.7	3.25	18.8	4.16	21.8	5.20	23.3	5.38	23.6	5.41	24.4	5.47	25.1	5.53		
		39	15.7	3.45	18.8	4.43	21.8	5.53	22.9	5.56	23.3	5.60	24.0	5.66	24.7	5.73		
		120	240 (26.88)	10	14.5	1.61	17.3	1.93	20.1	2.26	21.5	2.43	22.9	2.60	25.7	2.93	28.5	3.24
				12	14.5	1.64	17.3	1.97	20.1	2.30	21.5	2.47	22.9	2.64	25.7	2.98	28.5	3.22
				14	14.5	1.67	17.3	2.00	20.1	2.34	21.5	2.52	22.9	2.69	25.7	3.04	28.5	3.35
16	14.5			1.70	17.3	2.04	20.1	2.39	21.5	2.56	22.9	2.76	25.7	3.27	28.3	3.54		
18	14.5			1.72	17.3	2.07	20.1	2.46	21.5	2.71	22.9	2.97	25.7	3.52	28.0	3.72		
20	14.5			1.76	17.3	2.15	20.1	2.64	21.5	2.91	22.9	3.19	25.7	3.79	27.6	3.90		
21	14.5			1.77	17.3	2.22	20.1	2.74	21.5	3.01	22.9	3.30	25.7	3.92	27.4	3.99		
23	14.5			1.89	17.3	2.38	20.1	2.93	21.5	3.23	22.9	3.54	25.7	4.14	27.1	4.17		
25	14.5			2.01	17.3	2.54	20.1	3.13	21.5	3.45	22.9	3.79	25.7	4.32	26.7	4.36		
27	14.5			2.15	17.3	2.71	20.1	3.35	21.5	3.69	22.9	4.05	25.7	4.50	26.3	4.54		
29	14.5			2.28	17.3	2.89	20.1	3.57	21.5	3.94	22.9	4.33	25.3	4.68	26.0	4.73		
31	14.5			2.43	17.3	3.08	20.1	3.81	21.5	4.21	22.9	4.63	24.9	4.87	25.6	4.92		
33	14.5			2.58	17.3	3.28	20.1	4.06	21.5	4.49	22.9	4.94	24.6	5.05	25.2	5.10		
35	14.5			2.74	17.3	3.49	20.1	4.33	21.5	4.79	22.9	5.19	24.2	5.24	24.9	5.29		
37	14.5			2.91	17.3	3.71	20.1	4.61	21.5	5.10	22.9	5.37	23.9	5.43	24.5	5.48		
39	14.5			3.09	17.3	3.95	20.1	4.91	21.5	5.43	22.8	5.56	23.5	5.62	24.1	5.68		
110	220 (24.64)			10	13.3	1.48	15.9	1.77	18.4	2.06	19.7	2.22	21.0	2.37	23.6	2.68	26.1	2.99
				12	13.3	1.50	15.9	1.80	18.4	2.10	19.7	2.25	21.0	2.41	23.6	2.72	26.1	3.04
				14	13.3	1.53	15.9	1.83	18.4	2.14	19.7	2.29	21.0	2.45	23.6	2.77	26.1	3.11
		16	13.3	1.55	15.9	1.86	18.4	2.17	19.7	2.34	21.0	2.50	23.6	2.87	26.1	3.35		
		18	13.3	1.58	15.9	1.89	18.4	2.21	19.7	2.40	21.0	2.62	23.6	3.09	26.1	3.61		
		20	13.3	1.61	15.9	1.93	18.4	2.34	19.7	2.57	21.0	2.81	23.6	3.32	26.1	3.87		
		21	13.3	1.62	15.9	1.98	18.4	2.42	19.7	2.66	21.0	2.91	23.6	3.44	26.1	3.96		
		23	13.3	1.69	15.9	2.12	18.4	2.59	19.7	2.85	21.0	3.12	23.6	3.69	26.1	4.14		
		25	13.3	1.80	15.9	2.26	18.4	2.77	19.7	3.05	21.0	3.34	23.6	3.95	26.1	4.32		
		27	13.3	1.92	15.9	2.41	18.4	2.96	19.7	3.26	21.0	3.57	23.6	4.23	25.8	4.51		
		29	13.3	2.04	15.9	2.57	18.4	3.16	19.7	3.47	21.0	3.81	23.6	4.52	25.4	4.69		
		31	13.3	2.17	15.9	2.73	18.4	3.37	19.7	3.71	21.0	4.06	23.6	4.83	25.0	4.88		
		33	13.3	2.31	15.9	2.91	18.4	3.58	19.7	3.95	21.0	4.33	23.6	5.01	24.7	5.06		
		35	13.3	2.45	15.9	3.09	18.4	3.82	19.7	4.21	21.0	4.62	23.6	5.20	24.3	5.25		
		37	13.3	2.60	15.9	3.29	18.4	4.06	19.7	4.48	21.0	4.92	23.4	5.38	24.0	5.44		
		39	13.3	2.76	15.9	3.49	18.4	4.32	19.7	4.77	21.0	5.24	23.0	5.57	23.6	5.63		
		100	200 (22.40)	10	12.1	1.35	14.4	1.60	16.8	1.87	17.9	2.00	19.1	2.14	21.4	2.42	23.7	2.70
				12	12.1	1.37	14.4	1.63	16.8	1.90	17.9	2.04	19.1	2.18	21.4	2.46	23.7	2.75
				14	12.1	1.39	14.4	1.66	16.8	1.93	17.9	2.07	19.1	2.22	21.4	2.51	23.7	2.80
16	12.1			1.41	14.4	1.68	16.8	1.97	17.9	2.11	19.1	2.26	21.4	2.55	23.7	2.91		
18	12.1			1.44	14.4	1.71	16.8	2.00	17.9	2.15	19.1	2.30	21.4	2.69	23.7	3.13		
20	12.1			1.46	14.4	1.74	16.8	2.06	17.9	2.25	19.1	2.46	21.4	2.89	23.7	3.36		
21	12.1			1.47	14.4	1.76	16.8	2.13	17.9	2.33	19.1	2.54	21.4	3.00	23.7	3.48		
23	12.1			1.51	14.4	1.87	16.8	2.28	17.9	2.49	19.1	2.72	21.4	3.21	23.7	3.74		
25	12.1			1.61	14.4	2.00	16.8	2.43	17.9	2.67	19.1	2.91	21.4	3.43	23.7	4.00		
27	12.1			1.71	14.4	2.13	16.8	2.59	17.9	2.85	19.1	3.11	21.4	3.67	23.7	4.28		
29	12.1			1.82	14.4	2.27	16.8	2.77	17.9	3.03	19.1	3.32	21.4	3.92	23.7	4.57		
31	12.1			1.93	14.4	2.41	16.8	2.95	17.9	3.23	19.1	3.54	21.4	4.18	23.7	4.83		
33	12.1			2.05	14.4	2.56	16.8	3.14	17.9	3.44	19.1	3.77	21.4	4.46	23.7	5.02		
35	12.1			2.17	14.4	2.72	16.8	3.34	17.9	3.67	19.1	4.01	21.4	4.76	23.7	5.20		
37	12.1			2.30	14.4	2.89	16.8	3.55	17.9	3.90	19.1	4.27	21.4	5.07	23.4	5.39		
39	12.1			2.44	14.4	3.07	16.8	3.77	17.9	4.15	19.1	4.55	21.4	5.40	23.0	5.57		

4TW33912-3A(5)

4 Capacity tables

4 - 1 Cooling Capacity Tables

RXYRQ8P - Correction factor for mixed connection: 0.8

TC: Total Capacity: kW ; PI: Power Input: kW (compressor + outdoor fan motor)

Combination (%)	Capacity index (kW)	Outdoor air temp. °CDB	Indoor air temperature:													
			14.0 °CWB		16.0 °CWB		18.0 °CWB		19.0 °CWB		20.0 °CWB		22.0 °CWB		24.0 °CWB	
			TC	PI	TC	PI	TC	PI	TC	PI	TC	PI	TC	PI	TC	PI
90 (20.16)	180	10	10.9	1.22	13.0	1.44	15.1	1.68	16.1	1.80	17.2	1.92	19.3	2.16	21.4	2.42
		12	10.9	1.24	13.0	1.47	15.1	1.70	16.1	1.83	17.2	1.95	19.3	2.20	21.4	2.46
		14	10.9	1.26	13.0	1.49	15.1	1.73	16.1	1.86	17.2	1.98	19.3	2.24	21.4	2.50
		16	10.9	1.28	13.0	1.52	15.1	1.76	16.1	1.89	17.2	2.02	19.3	2.28	21.4	2.55
		18	10.9	1.30	13.0	1.54	15.1	1.79	16.1	1.92	17.2	2.06	19.3	2.32	21.4	2.69
		20	10.9	1.32	13.0	1.57	15.1	1.83	16.1	1.96	17.2	2.13	19.3	2.49	21.4	2.88
		21	10.9	1.33	13.0	1.58	15.1	1.86	16.1	2.03	17.2	2.20	19.3	2.58	21.4	2.99
		23	10.9	1.35	13.0	1.64	15.1	1.98	16.1	2.16	17.2	2.36	19.3	2.76	21.4	3.20
		25	10.9	1.42	13.0	1.75	15.1	2.12	16.1	2.31	17.2	2.52	19.3	2.95	21.4	3.42
		27	10.9	1.51	13.0	1.86	15.1	2.25	16.1	2.46	17.2	2.68	19.3	3.15	21.4	3.66
		29	10.9	1.61	13.0	1.98	15.1	2.40	16.1	2.63	17.2	2.86	19.3	3.36	21.4	3.91
		31	10.9	1.70	13.0	2.11	15.1	2.55	16.1	2.80	17.2	3.05	19.3	3.59	21.4	4.17
		33	10.9	1.81	13.0	2.24	15.1	2.72	16.1	2.98	17.2	3.25	19.3	3.82	21.4	4.45
		35	10.9	1.91	13.0	2.37	15.1	2.89	16.1	3.16	17.2	3.45	19.3	4.07	21.4	4.74
		37	10.9	2.02	13.0	2.52	15.1	3.07	16.1	3.36	17.2	3.67	19.3	4.34	21.4	5.05
		39	10.9	2.14	13.0	2.67	15.1	3.26	16.1	3.57	17.2	3.91	19.3	4.61	21.4	5.38
80 (17.92)	160	10	9.7	1.10	11.5	1.29	13.4	1.49	14.3	1.59	15.3	1.70	17.1	1.91	19.0	2.13
		12	9.7	1.12	11.5	1.31	13.4	1.51	14.3	1.62	15.3	1.73	17.1	1.94	19.0	2.17
		14	9.7	1.13	11.5	1.33	13.4	1.54	14.3	1.65	15.3	1.76	17.1	1.98	19.0	2.21
		16	9.7	1.15	11.5	1.35	13.4	1.56	14.3	1.67	15.3	1.79	17.1	2.01	19.0	2.25
		18	9.7	1.17	11.5	1.37	13.4	1.59	14.3	1.70	15.3	1.82	17.1	2.05	19.0	2.29
		20	9.7	1.18	11.5	1.40	13.4	1.62	14.3	1.73	15.3	1.85	17.1	2.12	19.0	2.44
		21	9.7	1.19	11.5	1.41	13.4	1.63	14.3	1.75	15.3	1.89	17.1	2.19	19.0	2.53
		23	9.7	1.21	11.5	1.43	13.4	1.71	14.3	1.86	15.3	2.01	17.1	2.35	19.0	2.71
		25	9.7	1.25	11.5	1.52	13.4	1.82	14.3	1.98	15.3	2.15	17.1	2.51	19.0	2.89
		27	9.7	1.33	11.5	1.62	13.4	1.94	14.3	2.11	15.3	2.29	17.1	2.67	19.0	3.09
		29	9.7	1.41	11.5	1.72	13.4	2.06	14.3	2.25	15.3	2.44	17.1	2.85	19.0	3.30
		31	9.7	1.49	11.5	1.82	13.4	2.19	14.3	2.39	15.3	2.60	17.1	3.04	19.0	3.51
		33	9.7	1.58	11.5	1.93	13.4	2.33	14.3	2.54	15.3	2.76	17.1	3.23	19.0	3.74
		35	9.7	1.67	11.5	2.05	13.4	2.47	14.3	2.70	15.3	2.94	17.1	3.44	19.0	3.99
		37	9.7	1.77	11.5	2.17	13.4	2.62	14.3	2.87	15.3	3.12	17.1	3.66	19.0	4.24
		39	9.7	1.87	11.5	2.30	13.4	2.78	14.3	3.04	15.3	3.31	17.1	3.89	19.0	4.52

4TW33912-3A(6)

NOTES - ANMERKUNGEN - Σημειώσεις - NOTAS - REMARQUES - NOTE - OPMERKINGEN - Примечания - NOTLAR

- The above table shows the average value of conditions which may occur.
Die obige Tabelle zeigt den Durchschnittswert der Bedingungen, die auftreten können.
Στον παραπάνω πίνακα αναγράφεται η μέση τιμή για συνθήκες που μπορεί να προκύψουν.
La tabla de arriba muestra el valor medio de condiciones que pueden ocurrir.
Le tableau ci-dessus donne la valeur moyenne pour des conditions qui peuvent survenir.
La tabella in alto mostra il valore delle condizioni medie che si possono riscontrare.
De tabel hierboven geeft de gemiddelde waarde aan van situaties die kunnen voorvallen.
Таблица расположенная выше показывает среднее значение условий, которые могут наступить.
Yukarıdaki tablo meydana gelebilecek koşulların ortalama değerini göstermektedir.
- Correction factor for mixed connection: 0.8. For more information refer to the selection procedure.
Korrekturfaktoren für gemischten Anschluss: 0,8. Weitere Informationen finden Sie im Auswahlverfahren.
Συντελεστής διόρθωσης για συνδυαζόμενη σύνδεση: 0,8. Για περισσότερες πληροφορίες ανατρέξτε στη διαδικασία επιλογής.
Factor de corrección para conexión combinada: 0,8. Si desea más información, consulte el procedimiento de selección.
Facteur de correction pour connexion d'unités mixtes : 0,8. Pour plus d'informations, se reporter à la procédure de sélection.
Fattore di correzione per collegamento varie unità: 0,8. Per maggiori informazioni fare riferimento alla procedura di selezione.
Correctiefactor voor gemengde aansluiting: 0,8. Zie selectieprocedure voor meer informatie.
Поправочный коэффициент для комбинированного соединения: 0,8. Подробная информация приводится в разделе порядка выбора.
Karışık bağlantı için düzeltme faktörü: 0.8. Daha fazla bilgi için, seçim prosedürüne bakın.

4 Capacity tables

4 - 1 Cooling Capacity Tables

RXYRQ8P - Correction factor for mixed connection: 0.7		TC: Total Capacity: kW ; PI: Power Input: kW (compressor + outdoor fan motor)															
Combination (%)	Capacity index (kW)	Outdoor air temp. °CDB	Indoor air temperature:														
			14.0 °CWB		16.0 °CWB		18.0 °CWB		19.0 °CWB		20.0 °CWB		22.0 °CWB		24.0 °CWB		
			20.0 °CDB		23.0 °CDB		16.0 °CDB		27.0 °CDB		28.0 °CDB		30.0 °CDB		32.0 °CDB		
		TC		PI		TC		PI		TC		PI		TC		PI	
130	260 (29.12)	10	13.8	1.49	16.4	1.77	19.1	2.05	20.4	2.19	21.7	2.33	24.4	2.61	27.0	2.88	
		12	13.8	1.51	16.4	1.79	19.1	2.08	20.4	2.23	21.7	2.37	24.4	2.66	27.0	3.02	
		14	13.8	1.53	16.4	1.82	19.1	2.12	20.4	2.26	21.7	2.41	24.4	2.80	27.0	3.27	
		16	13.8	1.56	16.4	1.85	19.1	2.15	20.4	2.34	21.7	2.55	24.4	3.02	27.0	3.53	
		18	13.8	1.58	16.4	1.89	19.1	2.29	20.4	2.51	21.7	2.75	24.4	3.25	27.0	3.74	
		20	13.8	1.61	16.4	2.00	19.1	2.45	20.4	2.70	21.7	2.95	24.4	3.49	27.0	3.93	
		21	13.8	1.65	16.4	2.07	19.1	2.54	20.4	2.79	21.7	3.05	24.4	3.62	27.0	4.02	
		23	13.8	1.77	16.4	2.21	19.1	2.72	20.4	2.99	21.7	3.27	24.4	3.88	27.0	4.21	
		25	13.8	1.88	16.4	2.36	19.1	2.91	20.4	3.20	21.7	3.50	24.4	4.16	27.0	4.39	
		27	13.8	2.00	16.4	2.52	19.1	3.10	20.4	3.42	21.7	3.74	24.4	4.45	26.9	4.58	
		29	13.8	2.13	16.4	2.69	19.1	3.31	20.4	3.65	21.7	4.00	24.4	4.72	26.5	4.77	
		31	13.8	2.27	16.4	2.86	19.1	3.53	20.4	3.89	21.7	4.27	24.4	4.91	26.2	4.96	
		33	13.8	2.41	16.4	3.05	19.1	3.76	20.4	4.15	21.7	4.55	24.4	5.09	25.8	5.15	
		35	13.8	2.56	16.4	3.24	19.1	4.01	20.4	4.42	21.7	4.86	24.4	5.28	25.4	5.34	
		37	13.8	2.71	16.4	3.44	19.1	4.26	20.4	4.71	21.7	5.17	24.4	5.47	25.1	5.53	
		39	13.8	2.88	16.4	3.66	19.1	4.54	20.4	5.01	21.7	5.51	24.0	5.66	24.7	5.73	
120	240 (26.88)	10	12.7	1.38	15.1	1.63	17.6	1.89	18.8	2.02	20.0	2.16	22.5	2.42	24.9	2.67	
		12	12.7	1.40	15.1	1.66	17.6	1.92	18.8	2.06	20.0	2.19	22.5	2.46	24.9	2.71	
		14	12.7	1.42	15.1	1.68	17.6	1.95	18.8	2.09	20.0	2.23	22.5	2.50	24.9	2.90	
		16	12.7	1.44	15.1	1.71	17.6	1.99	18.8	2.13	20.0	2.28	22.5	2.69	24.9	3.13	
		18	12.7	1.47	15.1	1.74	17.6	2.05	18.8	2.25	20.0	2.45	22.5	2.89	24.9	3.37	
		20	12.7	1.49	15.1	1.80	17.6	2.20	18.8	2.41	20.0	2.63	22.5	3.10	24.9	3.62	
		21	12.7	1.50	15.1	1.87	17.6	2.27	18.8	2.49	20.0	2.72	22.5	3.22	24.9	3.75	
		23	12.7	1.60	15.1	1.99	17.6	2.43	18.8	2.67	20.0	2.92	22.5	3.45	24.9	4.02	
		25	12.7	1.71	15.1	2.13	17.6	2.60	18.8	2.85	20.0	3.12	22.5	3.69	24.9	4.31	
		27	12.7	1.81	15.1	2.27	17.6	2.77	18.8	3.05	20.0	3.33	22.5	3.94	24.9	4.54	
		29	12.7	1.93	15.1	2.42	17.6	2.96	18.8	3.25	20.0	3.56	22.5	4.21	24.9	4.73	
		31	12.7	2.05	15.1	2.57	17.6	3.15	18.8	3.47	20.0	3.79	22.5	4.50	24.9	4.92	
		33	12.7	2.18	15.1	2.73	17.6	3.36	18.8	3.69	20.0	4.05	22.5	4.80	24.9	5.10	
		35	12.7	2.31	15.1	2.90	17.6	3.57	18.8	3.93	20.0	4.31	22.5	5.12	24.9	5.29	
		37	12.7	2.45	15.1	3.09	17.6	3.80	18.8	4.19	20.0	4.59	22.5	5.43	24.5	5.48	
		39	12.7	2.60	15.1	3.28	17.6	4.04	18.8	4.45	20.0	4.89	22.5	5.62	24.1	5.68	
110	220 (24.64)	10	11.6	1.27	13.9	1.50	16.1	1.74	17.2	1.86	18.4	1.98	20.6	2.22	22.9	2.46	
		12	11.6	1.29	13.9	1.52	16.1	1.76	17.2	1.89	18.4	2.01	20.6	2.25	22.9	2.50	
		14	11.6	1.31	13.9	1.55	16.1	1.79	17.2	1.92	18.4	2.04	20.6	2.29	22.9	2.55	
		16	11.6	1.33	13.9	1.57	16.1	1.82	17.2	1.95	18.4	2.08	20.6	2.37	22.9	2.75	
		18	11.6	1.35	13.9	1.60	16.1	1.85	17.2	2.00	18.4	2.17	20.6	2.55	22.9	2.96	
		20	11.6	1.37	13.9	1.63	16.1	1.96	17.2	2.14	18.4	2.33	20.6	2.74	22.9	3.18	
		21	11.6	1.38	13.9	1.67	16.1	2.03	17.2	2.21	18.4	2.41	20.6	2.84	22.9	3.29	
		23	11.6	1.44	13.9	1.79	16.1	2.16	17.2	2.37	18.4	2.58	20.6	3.04	22.9	3.53	
		25	11.6	1.54	13.9	1.90	16.1	2.31	17.2	2.53	18.4	2.76	20.6	3.25	22.9	3.78	
		27	11.6	1.63	13.9	2.03	16.1	2.46	17.2	2.70	18.4	2.95	20.6	3.47	22.9	4.04	
		29	11.6	1.74	13.9	2.16	16.1	2.63	17.2	2.88	18.4	3.14	20.6	3.71	22.9	4.32	
		31	11.6	1.84	13.9	2.29	16.1	2.80	17.2	3.07	18.4	3.35	20.6	3.95	22.9	4.61	
		33	11.6	1.96	13.9	2.44	16.1	2.97	17.2	3.26	18.4	3.57	20.6	4.22	22.9	4.92	
		35	11.6	2.07	13.9	2.59	16.1	3.16	17.2	3.47	18.4	3.80	20.6	4.49	22.9	5.25	
		37	11.6	2.20	13.9	2.75	16.1	3.36	17.2	3.69	18.4	4.04	20.6	4.79	22.9	5.44	
		39	11.6	2.33	13.9	2.92	16.1	3.57	17.2	3.93	18.4	4.30	20.6	5.10	22.9	5.63	
100	200 (22.40)	10	10.6	1.17	12.6	1.37	14.7	1.58	15.7	1.69	16.7	1.80	18.7	2.02	20.8	2.23	
		12	10.6	1.18	12.6	1.39	14.7	1.61	15.7	1.71	16.7	1.83	18.7	2.05	20.8	2.27	
		14	10.6	1.20	12.6	1.41	14.7	1.63	15.7	1.74	16.7	1.86	18.7	2.08	20.8	2.31	
		16	10.6	1.22	12.6	1.43	14.7	1.66	15.7	1.77	16.7	1.89	18.7	2.12	20.8	2.40	
		18	10.6	1.24	12.6	1.46	14.7	1.69	15.7	1.80	16.7	1.92	18.7	2.23	20.8	2.58	
		20	10.6	1.26	12.6	1.48	14.7	1.73	15.7	1.89	16.7	2.05	18.7	2.40	20.8	2.77	
		21	10.6	1.27	12.6	1.49	14.7	1.79	15.7	1.95	16.7	2.12	18.7	2.48	20.8	2.87	
		23	10.6	1.30	12.6	1.59	14.7	1.91	15.7	2.09	16.7	2.27	18.7	2.65	20.8	3.07	
		25	10.6	1.38	12.6	1.69	14.7	2.04	15.7	2.23	16.7	2.42	18.7	2.84	20.8	3.29	
		27	10.6	1.46	12.6	1.80	14.7	2.17	15.7	2.37	16.7	2.58	18.7	3.03	20.8	3.51	
		29	10.6	1.55	12.6	1.91	14.7	2.31	15.7	2.53	16.7	2.75	18.7	3.23	20.8	3.75	
		31	10.6	1.65	12.6	2.03	14.7	2.46	15.7	2.69	16.7	2.93	18.7	3.45	20.8	4.00	
		33	10.6	1.75	12.6	2.16	14.7	2.62	15.7	2.86	16.7	3.12	18.7	3.67	20.8	4.27	
		35	10.6	1.85	12.6	2.29	14.7	2.78	15.7	3.04	16.7	3.32	18.7	3.91	20.8	4.55	
		37	10.6	1.96	12.6	2.43	14.7	2.95	15.7	3.24	16.7	3.53	18.7	4.16	20.8	4.84	
		39	10.6	2.07	12.6	2.58	14.7	3.14	15.7	3.44	16.7	3.75	18.7	4.43	20.8	5.16	

4TW33912-3A(7)

4 Capacity tables

4 - 1 Cooling Capacity Tables

RXYRQ8P - Correction factor for mixed connection: 0.7

TC: Total Capacity: kW; PI: Power Input: kW (compressor + outdoor fan motor)

Combination (%)	Capacity index (kW)	Outdoor air temp. °CDB	Indoor air temperature:													
			14.0 °CWB		16.0 °CWB		18.0 °CWB		19.0 °CWB		20.0 °CWB		22.0 °CWB		24.0 °CWB	
			TC	PI	TC	PI	TC	PI	TC	PI	TC	PI	TC	PI	TC	PI
90	180 (20.16)	10	9.5	1.07	11.4	1.24	13.2	1.43	14.1	1.52	15.0	1.62	16.9	1.81	18.7	2.01
		12	9.5	1.08	11.4	1.26	13.2	1.45	14.1	1.55	15.0	1.64	16.9	1.84	18.7	2.04
		14	9.5	1.10	11.4	1.28	13.2	1.47	14.1	1.57	15.0	1.67	16.9	1.87	18.7	2.08
		16	9.5	1.11	11.4	1.30	13.2	1.50	14.1	1.60	15.0	1.70	16.9	1.91	18.7	2.11
		18	9.5	1.13	11.4	1.32	13.2	1.52	14.1	1.62	15.0	1.73	16.9	1.94	18.7	2.23
		20	9.5	1.14	11.4	1.34	13.2	1.55	14.1	1.65	15.0	1.79	16.9	2.08	18.7	2.39
		21	9.5	1.15	11.4	1.35	13.2	1.57	14.1	1.71	15.0	1.85	16.9	2.15	18.7	2.47
		23	9.5	1.17	11.4	1.40	13.2	1.68	14.1	1.82	15.0	1.97	16.9	2.30	18.7	2.65
		25	9.5	1.23	11.4	1.49	13.2	1.79	14.1	1.94	15.0	2.11	16.9	2.45	18.7	2.83
		27	9.5	1.30	11.4	1.59	13.2	1.90	14.1	2.07	15.0	2.25	16.9	2.62	18.7	3.02
		29	9.5	1.38	11.4	1.69	13.2	2.02	14.1	2.20	15.0	2.39	16.9	2.79	18.7	3.22
		31	9.5	1.47	11.4	1.79	13.2	2.15	14.1	2.34	15.0	2.54	16.9	2.97	18.7	3.44
		33	9.5	1.55	11.4	1.90	13.2	2.28	14.1	2.49	15.0	2.70	16.9	3.16	18.7	3.66
		35	9.5	1.64	11.4	2.01	13.2	2.42	14.1	2.64	15.0	2.87	16.9	3.37	18.7	3.90
		37	9.5	1.73	11.4	2.13	13.2	2.57	14.1	2.81	15.0	3.05	16.9	3.58	18.7	4.15
		39	9.5	1.83	11.4	2.26	13.2	2.73	14.1	2.98	15.0	3.24	16.9	3.81	18.7	4.41
80	160 (17.92)	10	8.5	0.97	10.1	1.12	11.7	1.28	12.5	1.36	13.4	1.45	15.0	1.62	16.6	1.79
		12	8.5	0.98	10.1	1.14	11.7	1.30	12.5	1.38	13.4	1.47	15.0	1.64	16.6	1.82
		14	8.5	0.99	10.1	1.15	11.7	1.32	12.5	1.40	13.4	1.49	15.0	1.67	16.6	1.85
		16	8.5	1.01	10.1	1.17	11.7	1.34	12.5	1.43	13.4	1.51	15.0	1.69	16.6	1.88
		18	8.5	1.02	10.1	1.19	11.7	1.36	12.5	1.45	13.4	1.54	15.0	1.72	16.6	1.91
		20	8.5	1.04	10.1	1.21	11.7	1.38	12.5	1.47	13.4	1.57	15.0	1.78	16.6	2.04
		21	8.5	1.04	10.1	1.21	11.7	1.39	12.5	1.49	13.4	1.60	15.0	1.84	16.6	2.11
		23	8.5	1.06	10.1	1.23	11.7	1.46	12.5	1.58	13.4	1.70	15.0	1.97	16.6	2.25
		25	8.5	1.09	10.1	1.31	11.7	1.55	12.5	1.68	13.4	1.81	15.0	2.10	16.6	2.41
		27	8.5	1.15	10.1	1.39	11.7	1.65	12.5	1.79	13.4	1.93	15.0	2.24	16.6	2.57
		29	8.5	1.22	10.1	1.47	11.7	1.75	12.5	1.90	13.4	2.05	15.0	2.38	16.6	2.74
		31	8.5	1.29	10.1	1.56	11.7	1.86	12.5	2.02	13.4	2.18	15.0	2.54	16.6	2.91
		33	8.5	1.37	10.1	1.66	11.7	1.97	12.5	2.14	13.4	2.32	15.0	2.70	16.6	3.10
		35	8.5	1.44	10.1	1.75	11.7	2.09	12.5	2.27	13.4	2.46	15.0	2.86	16.6	3.30
		37	8.5	1.53	10.1	1.85	11.7	2.22	12.5	2.41	13.4	2.61	15.0	3.04	16.6	3.51
		39	8.5	1.61	10.1	1.96	11.7	2.35	12.5	2.56	13.4	2.77	15.0	3.23	16.6	3.73

4TW33912-3A(8)

NOTES - ANMERKUNGEN - Σημειώσεις - NOTAS - REMARQUES - NOTE - OPMERKINGEN - Примечания - NOTLAR

- The above table shows the average value of conditions which may occur.
Die obige Tabelle zeigt den Durchschnittswert der Bedingungen, die auftreten können.
Στον παραπάνω πίνακα αναγράφεται η μέση τιμή για συνθήκες που μπορεί να προκύψουν.
La tabla de arriba muestra el valor medio de condiciones que pueden ocurrir.
Le tableau ci-dessus donne la valeur moyenne pour des conditions qui peuvent survenir.
La tabella in alto mostra il valore delle condizioni medie che si possono riscontrare.
De tabel hierboven geeft de gemiddelde waarde aan van situaties die kunnen voorvallen.
Таблица расположенная выше показывает среднее значение условий, которые могут наступить.
Yukarıdaki tablo meydana gelebilecek koşulların ortalama değerini göstermektedir.
- Correction factor for mixed connection: 0.7. For more information refer to the selection procedure.
Korrekturfaktoren für gemischten Anschluss: 0,7. Weitere Informationen finden Sie im Auswahlverfahren.
Συντελεστής διόρθωσης για συνδυαζόμενη σύνδεση: 0,7. Για περισσότερες πληροφορίες ανατρέξτε στη διαδικασία επιλογής.
Factor de corrección para conexión combinada: 0,7. Si desea más información, consulte el procedimiento de selección.
Facteur de correction pour connexion d'unités mixtes : 0,7. Pour plus d'informations, se reporter à la procédure de sélection.
Fattore di correzione per collegamento varie unità: 0,7. Per maggiori informazioni fare riferimento alla procedura di selezione.
Correctiefactor voor gemengde aansluiting: 0,7. Zie selectieprocedure voor meer informatie.
Поправочный коэффициент для комбинированного соединения: 0,7. Подробная информация приводится в разделе порядка выбора.
Karışık bağlantı için düzeltme faktörü: 0.7. Daha fazla bilgi için, seçim prosedürüne bakın.

4 Capacity tables

4 - 1 Cooling Capacity Tables

RXYRQ8P - Correction factor for mixed connection: 0.6

TC: Total Capacity: kW ; PI: Power Input: kW (compressor + outdoor fan motor)

Combination (%)	Capacity index (kW)	Outdoor air temp. °CDB	Indoor air temperature:															
			14.0 °CWB		16.0 °CWB		18.0 °CWB		19.0 °CWB		20.0 °CWB		22.0 °CWB		24.0 °CWB			
			20.0 °CDB		23.0 °CDB		16.0 °CDB		27.0 °CDB		28.0 °CDB		30.0 °CDB		32.0 °CDB			
			TC	PI	TC	PI	TC	PI	TC	PI	TC	PI	TC	PI	TC	PI		
130	260 (29.12)	10	11.8	1.25	14.1	1.46	16.3	1.67	17.5	1.78	18.6	1.89	20.9	2.10	23.2	2.30		
		12	11.8	1.26	14.1	1.48	16.3	1.70	17.5	1.81	18.6	1.92	20.9	2.13	23.2	2.41		
		14	11.8	1.28	14.1	1.50	16.3	1.73	17.5	1.84	18.6	1.95	20.9	2.24	23.2	2.60		
		16	11.8	1.30	14.1	1.53	16.3	1.75	17.5	1.89	18.6	2.06	20.9	2.42	23.2	2.80		
		18	11.8	1.32	14.1	1.55	16.3	1.86	17.5	2.03	18.6	2.21	20.9	2.60	23.2	3.02		
		20	11.8	1.34	14.1	1.64	16.3	1.99	17.5	2.18	18.6	2.37	20.9	2.79	23.2	3.24		
		21	11.8	1.38	14.1	1.70	16.3	2.06	17.5	2.25	18.6	2.46	20.9	2.89	23.2	3.36		
		23	11.8	1.47	14.1	1.81	16.3	2.20	17.5	2.41	18.6	2.63	20.9	3.09	23.2	3.60		
		25	11.8	1.56	14.1	1.93	16.3	2.35	17.5	2.57	18.6	2.81	20.9	3.31	23.2	3.85		
		27	11.8	1.66	14.1	2.06	16.3	2.51	17.5	2.75	18.6	3.00	20.9	3.54	23.2	4.12		
		29	11.8	1.76	14.1	2.19	16.3	2.67	17.5	2.93	18.6	3.20	20.9	3.78	23.2	4.40		
		31	11.8	1.87	14.1	2.33	16.3	2.85	17.5	3.12	18.6	3.41	20.9	4.03	23.2	4.70		
		33	11.8	1.99	14.1	2.48	16.3	3.03	17.5	3.32	18.6	3.63	20.9	4.30	23.2	5.02		
		35	11.8	2.11	14.1	2.63	16.3	3.22	17.5	3.54	18.6	3.87	20.9	4.58	23.2	5.34		
		37	11.8	2.23	14.1	2.79	16.3	3.42	17.5	3.76	18.6	4.12	20.9	4.88	23.2	5.53		
		39	11.8	2.36	14.1	2.97	16.3	3.64	17.5	4.00	18.6	4.38	20.9	5.20	23.2	5.73		
		120	240 (26.88)	10	10.9	1.16	13.0	1.36	15.1	1.55	16.1	1.65	17.2	1.75	19.3	1.95	21.4	2.14
				12	10.9	1.18	13.0	1.38	15.1	1.58	16.1	1.68	17.2	1.78	19.3	1.98	21.4	2.17
14	10.9			1.19	13.0	1.40	15.1	1.60	16.1	1.71	17.2	1.81	19.3	2.01	21.4	2.32		
16	10.9			1.21	13.0	1.42	15.1	1.63	16.1	1.73	17.2	1.85	19.3	2.16	21.4	2.50		
18	10.9			1.23	13.0	1.44	15.1	1.68	16.1	1.83	17.2	1.99	19.3	2.32	21.4	2.69		
20	10.9			1.25	13.0	1.49	15.1	1.79	16.1	1.96	17.2	2.13	19.3	2.49	21.4	2.88		
21	10.9			1.26	13.0	1.54	15.1	1.86	16.1	2.03	17.2	2.20	19.3	2.58	21.4	2.99		
23	10.9			1.34	13.0	1.64	15.1	1.98	16.1	2.16	17.2	2.36	19.3	2.76	21.4	3.20		
25	10.9			1.42	13.0	1.75	15.1	2.12	16.1	2.31	17.2	2.52	19.3	2.95	21.4	3.42		
27	10.9			1.51	13.0	1.86	15.1	2.25	16.1	2.46	17.2	2.68	19.3	3.15	21.4	3.66		
29	10.9			1.61	13.0	1.98	15.1	2.40	16.1	2.63	17.2	2.86	19.3	3.36	21.4	3.91		
31	10.9			1.70	13.0	2.11	15.1	2.55	16.1	2.80	17.2	3.05	19.3	3.59	21.4	4.17		
33	10.9			1.81	13.0	2.24	15.1	2.72	16.1	2.98	17.2	3.25	19.3	3.82	21.4	4.45		
35	10.9			1.91	13.0	2.37	15.1	2.89	16.1	3.16	17.2	3.45	19.3	4.07	21.4	4.74		
37	10.9			2.02	13.0	2.52	15.1	3.07	16.1	3.36	17.2	3.67	19.3	4.34	21.4	5.05		
39	10.9			2.14	13.0	2.67	15.1	3.26	16.1	3.57	17.2	3.91	19.3	4.61	21.4	5.38		
110	220 (24.64)			10	10.0	1.08	11.9	1.26	13.8	1.44	14.8	1.53	15.7	1.62	17.7	1.80	19.6	1.98
				12	10.0	1.09	11.9	1.27	13.8	1.46	14.8	1.55	15.7	1.64	17.7	1.83	19.6	2.01
		14	10.0	1.11	11.9	1.29	13.8	1.48	14.8	1.57	15.7	1.67	17.7	1.86	19.6	2.05		
		16	10.0	1.13	11.9	1.31	13.8	1.50	14.8	1.60	15.7	1.69	17.7	1.92	19.6	2.21		
		18	10.0	1.14	11.9	1.33	13.8	1.53	14.8	1.64	15.7	1.77	17.7	2.06	19.6	2.38		
		20	10.0	1.16	11.9	1.35	13.8	1.61	14.8	1.75	15.7	1.90	17.7	2.21	19.6	2.55		
		21	10.0	1.17	11.9	1.39	13.8	1.66	14.8	1.81	15.7	1.96	17.7	2.29	19.6	2.64		
		23	10.0	1.22	11.9	1.48	13.8	1.78	14.8	1.93	15.7	2.10	17.7	2.45	19.6	2.82		
		25	10.0	1.29	11.9	1.58	13.8	1.89	14.8	2.06	15.7	2.24	17.7	2.61	19.6	3.02		
		27	10.0	1.37	11.9	1.68	13.8	2.02	14.8	2.20	15.7	2.39	17.7	2.79	19.6	3.23		
		29	10.0	1.46	11.9	1.78	13.8	2.15	14.8	2.34	15.7	2.54	17.7	2.98	19.6	3.44		
		31	10.0	1.54	11.9	1.89	13.8	2.28	14.8	2.49	15.7	2.71	17.7	3.17	19.6	3.67		
		33	10.0	1.63	11.9	2.01	13.8	2.42	14.8	2.65	15.7	2.88	17.7	3.38	19.6	3.91		
		35	10.0	1.73	11.9	2.13	13.8	2.57	14.8	2.81	15.7	3.06	17.7	3.59	19.6	4.17		
		37	10.0	1.83	11.9	2.26	13.8	2.73	14.8	2.99	15.7	3.25	17.7	3.82	19.6	4.44		
		39	10.0	1.93	11.9	2.39	13.8	2.90	14.8	3.17	15.7	3.46	17.7	4.07	19.6	4.73		
		100	200 (22.40)	10	9.1	1.00	10.8	1.16	12.6	1.32	13.4	1.40	14.3	1.48	16.1	1.65	17.8	1.81
				12	9.1	1.01	10.8	1.17	12.6	1.34	13.4	1.42	14.3	1.50	16.1	1.67	17.8	1.84
14	9.1			1.03	10.8	1.19	12.6	1.36	13.4	1.44	14.3	1.53	16.1	1.70	17.8	1.87		
16	9.1			1.04	10.8	1.21	12.6	1.38	13.4	1.46	14.3	1.55	16.1	1.73	17.8	1.94		
18	9.1			1.05	10.8	1.22	12.6	1.40	13.4	1.49	14.3	1.58	16.1	1.82	17.8	2.08		
20	9.1			1.07	10.8	1.24	12.6	1.43	13.4	1.55	14.3	1.68	16.1	1.95	17.8	2.23		
21	9.1			1.08	10.8	1.25	12.6	1.48	13.4	1.61	14.3	1.74	16.1	2.01	17.8	2.31		
23	9.1			1.10	10.8	1.33	12.6	1.58	13.4	1.72	14.3	1.86	16.1	2.15	17.8	2.47		
25	9.1			1.17	10.8	1.41	12.6	1.68	13.4	1.83	14.3	1.98	16.1	2.30	17.8	2.64		
27	9.1			1.24	10.8	1.50	12.6	1.79	13.4	1.95	14.3	2.11	16.1	2.45	17.8	2.82		
29	9.1			1.31	10.8	1.59	12.6	1.90	13.4	2.07	14.3	2.24	16.1	2.61	17.8	3.01		
31	9.1			1.39	10.8	1.69	12.6	2.02	13.4	2.20	14.3	2.39	16.1	2.78	17.8	3.21		
33	9.1			1.47	10.8	1.79	12.6	2.15	13.4	2.34	14.3	2.54	16.1	2.96	17.8	3.41		
35	9.1			1.56	10.8	1.90	12.6	2.28	13.4	2.48	14.3	2.69	16.1	3.15	17.8	3.63		
37	9.1			1.64	10.8	2.01	12.6	2.42	13.4	2.63	14.3	2.86	16.1	3.34	17.8	3.87		
39	9.1			1.74	10.8	2.13	12.6	2.56	13.4	2.79	14.3	3.04	16.1	3.55	17.8	4.11		

4TW33912-3A(9)

4 Capacity tables

4 - 1 Cooling Capacity Tables

RXYRQ8P - Correction factor for mixed connection: 0.6

TC: Total Capacity: kW ; PI: Power Input: kW (compressor + outdoor fan motor)

Combination (%)	Capacity index (kW)	Outdoor air temp. °CDB	Indoor air temperature:													
			14.0 °CWB		16.0 °CWB		18.0 °CWB		19.0 °CWB		20.0 °CWB		22.0 °CWB		24.0 °CWB	
			TC	PI	TC	PI	TC	PI	TC	PI	TC	PI	TC	PI	TC	PI
90	180 (20.16)	10	8.2	0.92	9.7	1.06	11.3	1.20	12.1	1.27	12.9	1.35	14.5	1.50	16.0	1.65
		12	8.2	0.93	9.7	1.07	11.3	1.22	12.1	1.29	12.9	1.37	14.5	1.52	16.0	1.67
		14	8.2	0.94	9.7	1.09	11.3	1.24	12.1	1.31	12.9	1.39	14.5	1.54	16.0	1.70
		16	8.2	0.96	9.7	1.10	11.3	1.25	12.1	1.33	12.9	1.41	14.5	1.56	16.0	1.72
		18	8.2	0.97	9.7	1.12	11.3	1.27	12.1	1.35	12.9	1.43	14.5	1.59	16.0	1.81
		20	8.2	0.98	9.7	1.13	11.3	1.29	12.1	1.37	12.9	1.48	14.5	1.70	16.0	1.94
		21	8.2	0.99	9.7	1.14	11.3	1.31	12.1	1.42	12.9	1.53	14.5	1.76	16.0	2.01
		23	8.2	1.00	9.7	1.18	11.3	1.40	12.1	1.51	12.9	1.63	14.5	1.88	16.0	2.15
		25	8.2	1.05	9.7	1.26	11.3	1.49	12.1	1.61	12.9	1.74	14.5	2.00	16.0	2.29
		27	8.2	1.11	9.7	1.34	11.3	1.58	12.1	1.71	12.9	1.85	14.5	2.13	16.0	2.44
		29	8.2	1.18	9.7	1.42	11.3	1.68	12.1	1.82	12.9	1.96	14.5	2.27	16.0	2.60
		31	8.2	1.25	9.7	1.50	11.3	1.78	12.1	1.93	12.9	2.09	14.5	2.42	16.0	2.77
33	8.2	1.32	9.7	1.59	11.3	1.89	12.1	2.05	12.9	2.22	14.5	2.57	16.0	2.95		
35	8.2	1.39	9.7	1.68	11.3	2.00	12.1	2.17	12.9	2.35	14.5	2.73	16.0	3.14		
37	8.2	1.47	9.7	1.78	11.3	2.12	12.1	2.30	12.9	2.49	14.5	2.90	16.0	3.33		
39	8.2	1.55	9.7	1.88	11.3	2.25	12.1	2.44	12.9	2.64	14.5	3.08	16.0	3.54		
80	160 (17.92)	10	7.3	0.84	8.7	0.96	10.1	1.09	10.8	1.15	11.5	1.21	12.8	1.34	14.2	1.48
		12	7.3	0.85	8.7	0.98	10.1	1.10	10.8	1.17	11.5	1.23	12.8	1.36	14.2	1.50
		14	7.3	0.86	8.7	0.99	10.1	1.12	10.8	1.18	11.5	1.25	12.8	1.38	14.2	1.52
		16	7.3	0.87	8.7	1.00	10.1	1.13	10.8	1.20	11.5	1.27	12.8	1.40	14.2	1.54
		18	7.3	0.89	8.7	1.01	10.1	1.15	10.8	1.22	11.5	1.29	12.8	1.43	14.2	1.57
		20	7.3	0.90	8.7	1.03	10.1	1.17	10.8	1.24	11.5	1.31	12.8	1.47	14.2	1.67
		21	7.3	0.90	8.7	1.04	10.1	1.17	10.8	1.25	11.5	1.33	12.8	1.52	14.2	1.73
		23	7.3	0.91	8.7	1.05	10.1	1.23	10.8	1.32	11.5	1.42	12.8	1.62	14.2	1.84
		25	7.3	0.94	8.7	1.11	10.1	1.30	10.8	1.40	11.5	1.51	12.8	1.73	14.2	1.97
		27	7.3	1.00	8.7	1.18	10.1	1.38	10.8	1.49	11.5	1.60	12.8	1.84	14.2	2.10
		29	7.3	1.05	8.7	1.25	10.1	1.47	10.8	1.58	11.5	1.70	12.8	1.96	14.2	2.23
		31	7.3	1.11	8.7	1.32	10.1	1.56	10.8	1.68	11.5	1.81	12.8	2.08	14.2	2.37
33	7.3	1.17	8.7	1.40	10.1	1.65	10.8	1.78	11.5	1.92	12.8	2.21	14.2	2.52		
35	7.3	1.24	8.7	1.48	10.1	1.74	10.8	1.88	11.5	2.03	12.8	2.34	14.2	2.68		
37	7.3	1.30	8.7	1.56	10.1	1.84	10.8	2.00	11.5	2.15	12.8	2.49	14.2	2.84		
39	7.3	1.37	8.7	1.65	10.1	1.95	10.8	2.11	11.5	2.28	12.8	2.64	14.2	3.02		

4TW33912-3A(10)

NOTES - ANMERKUNGEN - Σημειώσεις - NOTAS - REMARQUES - NOTE - OPMERKINGEN - Примечания - NOTLAR

- The above table shows the average value of conditions which may occur.
Die obige Tabelle zeigt den Durchschnittswert der Bedingungen, die auftreten können.
Στον παραπάνω πίνακα αναγράφεται η μέση τιμή για συνθήκες που μπορεί να προκύψουν.
La tabla de arriba muestra el valor medio de condiciones que pueden ocurrir.
Le tableau ci-dessus donne la valeur moyenne pour des conditions qui peuvent survenir.
La tabella in alto mostra il valore delle condizioni medie che si possono riscontrare.
De tabel hierboven geeft de gemiddelde waarde aan van situaties die kunnen voorvallen.
Таблица расположенная выше показывает среднее значение условий, которые могут наступить.
Yukarıdaki tablo meydana gelebilecek koşulların ortalama değerini göstermektedir.
- Correction factor for mixed connection: 0.6. For more information refer to the selection procedure.
Korrekturfaktoren für gemischten Anschluss: 0,6. Weitere Informationen finden Sie im Auswahlverfahren.
Συντελεστής διόρθωσης για συνδυαζόμενη σύνδεση: 0,6. Για περισσότερες πληροφορίες ανατρέξτε στη διαδικασία επιλογής.
Factor de corrección para conexión combinada: 0,6. Si desea más información, consulte el procedimiento de selección.
Facteur de correction pour connexion d'unités mixtes : 0,6. Pour plus d'informations, se reporter à la procédure de sélection.
Fattore di correzione per collegamento varie unità: 0,6. Per maggiori informazioni fare riferimento alla procedura di selezione.
Correctiefactor voor gemengde aansluiting: 0,6. Zie selectieprocedure voor meer informatie.
Поправочный коэффициент для комбинированного соединения: 0,7. Подробная информация приводится в разделе порядка выбора.
Karışık bağlantı için düzeltme faktörü: 0.7. Daha fazla bilgi için, seçim prosedürüne bakın.

4 Capacity tables

4 - 1 Cooling Capacity Tables

RXYRQ10P - Correction factor for mixed connection: 1.0

TC: Total Capacity: kW; PI: Power Input: kW (compressor + outdoor fan motor)

Combination (%)	Capacity index (kW)	Outdoor air temp. °CDB	Indoor air temperature:													
			14.0 °CWB		16.0 °CWB		18.0 °CWB		19.0 °CWB		20.0 °CWB		22.0 °CWB		24.0 °CWB	
			TC	PI	TC	PI	TC	PI	TC	PI	TC	PI	TC	PI	TC	PI
90	225 (25.20)	10	17.0	2.19	20.3	2.64	23.6	3.12	25.2	3.37	26.8	3.62	30.1	4.14	33.4	4.66
		12	17.0	2.23	20.3	2.69	23.6	3.18	25.2	3.43	26.8	3.69	30.1	4.22	33.4	4.75
		14	17.0	2.27	20.3	2.74	23.6	3.24	25.2	3.50	26.8	3.76	30.1	4.30	33.4	4.84
		16	17.0	2.31	20.3	2.79	23.6	3.30	25.2	3.57	26.8	3.83	30.1	4.38	33.3	4.92
		18	17.0	2.35	20.3	2.84	23.6	3.37	25.2	3.64	26.8	3.91	30.1	4.47	32.9	5.08
		20	17.0	2.39	20.3	2.90	23.6	3.43	25.2	3.71	26.8	4.05	30.1	4.80	32.4	5.32
		21	17.0	2.42	20.3	2.93	23.6	3.49	25.2	3.84	26.8	4.20	30.1	4.97	32.2	5.45
		23	17.0	2.46	20.3	3.05	23.6	3.74	25.2	4.11	26.8	4.50	30.1	5.33	31.7	5.69
		25	17.0	2.59	20.3	3.25	23.6	4.00	25.2	4.40	26.8	4.81	30.1	5.71	31.3	5.94
		27	17.0	2.76	20.3	3.47	23.6	4.27	25.2	4.70	26.8	5.15	30.1	6.11	30.8	6.19
		29	17.0	2.94	20.3	3.70	23.6	4.55	25.2	5.01	26.8	5.50	29.8	6.40	30.4	6.44
		31	17.0	3.12	20.3	3.94	23.6	4.85	25.2	5.35	26.8	5.87	29.3	6.65	29.9	6.70
		33	17.0	3.32	20.3	4.19	23.6	5.17	25.2	5.70	26.8	6.26	28.9	6.90	29.5	6.95
		35	17.0	3.52	20.3	4.46	23.6	5.51	25.2	6.07	26.8	6.67	28.4	7.15	29.0	7.20
		37	17.0	3.74	20.3	4.74	23.6	5.86	25.2	6.47	26.8	7.11	27.9	7.40	28.6	7.46
		39	17.0	3.97	20.3	5.04	23.6	6.24	25.2	6.89	26.8	7.57	27.5	7.65	28.1	7.72
		80	200 (22.40)	10	15.1	1.95	18.0	2.33	20.9	2.74	22.4	2.95	23.9	3.17	26.8	3.61
12	15.1			1.98	18.0	2.37	20.9	2.79	22.4	3.00	23.9	3.23	26.8	3.68	29.7	4.14
14	15.1			2.01	18.0	2.41	20.9	2.84	22.4	3.06	23.9	3.29	26.8	3.75	29.7	4.22
16	15.1			2.04	18.0	2.46	20.9	2.89	22.4	3.12	23.9	3.35	26.8	3.82	29.7	4.31
18	15.1			2.08	18.0	2.50	20.9	2.95	22.4	3.18	23.9	3.41	26.8	3.90	29.7	4.39
20	15.1			2.12	18.0	2.55	20.9	3.00	22.4	3.24	23.9	3.48	26.8	4.04	29.7	4.70
21	15.1			2.14	18.0	2.57	20.9	3.03	22.4	3.27	23.9	3.55	26.8	4.18	29.7	4.87
23	15.1			2.18	18.0	2.62	20.9	3.18	22.4	3.49	23.9	3.80	26.8	4.48	29.7	5.22
25	15.1			2.25	18.0	2.79	20.9	3.40	22.4	3.72	23.9	4.07	26.8	4.80	29.7	5.59
27	15.1			2.39	18.0	2.97	20.9	3.62	22.4	3.98	23.9	4.34	26.8	5.13	29.7	5.98
29	15.1			2.54	18.0	3.17	20.9	3.86	22.4	4.24	23.9	4.63	26.8	5.48	29.7	6.39
31	15.1			2.70	18.0	3.37	20.9	4.11	22.4	4.52	23.9	4.94	26.8	5.84	29.2	6.64
33	15.1			2.86	18.0	3.58	20.9	4.38	22.4	4.81	23.9	5.26	26.8	6.23	28.8	6.89
35	15.1			3.03	18.0	3.80	20.9	4.66	22.4	5.12	23.9	5.61	26.8	6.64	28.3	7.14
37	15.1			3.22	18.0	4.04	20.9	4.95	22.4	5.45	23.9	5.97	26.8	7.08	27.9	7.39
39	15.1			3.41	18.0	4.29	20.9	5.27	22.4	5.80	23.9	6.35	26.8	7.54	27.4	7.64

4TW33912-3A(2)

NOTES - ANMERKUNGEN - Σημειώσεις - NOTAS - REMARQUES - NOTE - OPMERKINGEN - Примечания - NOTLAR

- The above table shows the average value of conditions which may occur.
Die obige Tabelle zeigt den Durchschnittswert der Bedingungen, die auftreten können.
Στον παραπάνω πίνακα αναγράφεται η μέση τιμή για συνθήκες που μπορεί να προκύψουν.
La tabla de arriba muestra el valor medio de condiciones que pueden ocurrir.
Le tableau ci-dessus donne la valeur moyenne pour des conditions qui peuvent survenir.
La tabella in alto mostra il valore delle condizioni medie che si possono riscontrare.
De tabel hierboven geeft de gemiddelde waarde aan van situaties die kunnen voorvallen.
Таблица расположенная выше показывает среднее значение условий, которые могут наступить.
Yukarıdaki tablo meydana gelebilecek koşulların ortalama değerini göstermektedir.
- Correction factor for mixed connection: 1.0. For more information refer to the selection procedure.
Korrekturfaktoren für gemischten Anschluss: 1,0. Weitere Informationen finden Sie im Auswahlverfahren.
Συντελεστής διόρθωσης για συνδυαζόμενη σύνδεση: 1,0. Για περισσότερες πληροφορίες ανατρέξτε στη διαδικασία επιλογής.
Factor de corrección para conexión combinada: 1,0. Si desea más información, consulte el procedimiento de selección.
Facteur de correction pour connexion d'unités mixtes : 1,0. Pour plus d'informations, se reporter à la procédure de sélection.
Fattore di correzione per collegamento varie unità: 1,0. Per maggiori informazioni fare riferimento alla procedura di selezione.
Correctiefactor voor gemengde aansluiting: 1,0. Zie selectieprocedure voor meer informatie.
Поправочный коэффициент для комбинированного соединения: 1,0. Подробная информация приводится в разделе порядка выбора.
Karışık bağlantı için düzeltme faktörü: 1.0. Daha fazla bilgi için, seçim prosedürüne bakın.

4 Capacity tables

4 - 1 Cooling Capacity Tables

RXYRQ10P - Correction factor for mixed connection: 0.9

TC: Total Capacity: kW ; PI: Power Input: kW (compressor + outdoor fan motor)

Combination (%)	Capacity index (kW)	Outdoor air temp. °CDB	Indoor air temperature:													
			14.0 °CWB		16.0 °CWB		18.0 °CWB		19.0 °CWB		20.0 °CWB		22.0 °CWB		24.0 °CWB	
			20.0 °CDB		23.0 °CDB		16.0 °CDB		27.0 °CDB		28.0 °CDB		30.0 °CDB		32.0 °CDB	
			TC	PI	TC	PI	TC	PI	TC	PI	TC	PI	TC	PI	TC	PI
130	325 (36.40)	10	22.1	2.84	26.4	3.45	30.6	4.08	32.8	4.39	34.9	4.71	36.6	4.57	37.5	4.36
		12	22.1	2.89	26.4	3.51	30.6	4.15	32.8	4.47	34.9	4.74	36.1	4.54	37.0	4.47
		14	22.1	2.95	26.4	3.58	30.6	4.23	32.8	4.55	34.8	4.71	35.7	4.68	36.6	4.72
		16	22.1	3.00	26.4	3.64	30.6	4.31	32.8	4.71	34.3	4.88	35.2	4.93	36.1	4.98
		18	22.1	3.06	26.4	3.71	30.6	4.58	32.8	5.07	33.9	5.13	34.8	5.18	35.7	5.23
		20	22.1	3.11	26.4	3.95	30.6	4.92	32.8	5.36	33.4	5.38	34.3	5.44	35.2	5.49
		21	22.1	3.20	26.4	4.09	30.6	5.10	32.8	5.48	33.2	5.51	34.1	5.56	35.0	5.62
		23	22.1	3.42	26.4	4.39	30.6	5.47	32.3	5.73	32.7	5.76	33.6	5.82	34.5	5.88
		25	22.1	3.66	26.4	4.69	30.6	5.86	31.8	5.98	32.3	6.01	33.2	6.07	34.1	6.14
		27	22.1	3.90	26.4	5.02	30.6	6.20	31.4	6.23	31.8	6.27	32.7	6.33	33.6	6.40
		29	22.1	4.16	26.4	5.36	30.5	6.45	30.9	6.49	31.4	6.52	32.3	6.59	33.2	6.66
		31	22.1	4.44	26.4	5.72	30.0	6.71	30.5	6.74	30.9	6.78	31.8	6.85	32.7	6.93
		33	22.1	4.72	26.4	6.09	29.6	6.96	30.0	7.00	30.5	7.04	31.4	7.11	32.2	7.19
		35	22.1	5.03	26.4	6.50	29.1	7.21	29.6	7.25	30.0	7.30	30.9	7.38	31.8	7.46
		37	22.1	5.35	26.4	6.92	28.7	7.47	29.1	7.51	29.6	7.56	30.4	7.64	31.3	7.73
		39	22.1	5.69	26.4	7.37	28.2	7.73	28.7	7.77	29.1	7.82	30.0	7.91	30.9	8.00
120	300 (33.60)	10	20.4	2.61	24.3	3.16	28.3	3.73	30.2	4.02	32.2	4.31	36.0	4.71	36.8	4.52
		12	20.4	2.65	24.3	3.22	28.3	3.80	30.2	4.09	32.2	4.39	35.5	4.68	36.3	4.49
		14	20.4	2.70	24.3	3.27	28.3	3.87	30.2	4.17	32.2	4.47	35.1	4.65	35.9	4.69
		16	20.4	2.75	24.3	3.33	28.3	3.94	30.2	4.25	32.2	4.59	34.6	4.90	35.4	4.94
		18	20.4	2.80	24.3	3.40	28.3	4.07	30.2	4.49	32.2	4.94	34.1	5.15	35.0	5.19
		20	20.4	2.85	24.3	3.53	28.3	4.37	30.2	4.83	32.2	5.31	33.7	5.40	34.5	5.45
		21	20.4	2.88	24.3	3.65	28.3	4.53	30.2	5.00	32.2	5.47	33.5	5.52	34.3	5.57
		23	20.4	3.07	24.3	3.91	28.3	4.86	30.2	5.37	32.2	5.72	33.0	5.78	33.8	5.83
		25	20.4	3.28	24.3	4.18	28.3	5.20	30.2	5.75	31.7	5.97	32.6	6.03	33.4	6.09
		27	20.4	3.50	24.3	4.47	28.3	5.56	30.2	6.15	31.3	6.23	32.1	6.29	32.9	6.35
		29	20.4	3.73	24.3	4.77	28.3	5.94	30.2	6.45	30.8	6.48	31.6	6.54	32.5	6.61
		31	20.4	3.97	24.3	5.09	28.3	6.34	30.0	6.70	30.4	6.73	31.2	6.80	32.0	6.87
		33	20.4	4.23	24.3	5.42	28.3	6.77	29.5	6.95	29.9	6.99	30.7	7.06	31.5	7.13
		35	20.4	4.49	24.3	5.77	28.3	7.17	29.0	7.21	29.5	7.24	30.3	7.32	31.1	7.40
		37	20.4	4.78	24.3	6.15	28.2	7.42	28.6	7.46	29.0	7.50	29.8	7.58	30.6	7.66
		39	20.4	5.08	24.3	6.54	27.7	7.68	28.1	7.72	28.5	7.76	29.4	7.85	30.2	7.93
110	275 (30.80)	10	18.7	2.38	22.3	2.87	25.9	3.39	27.7	3.65	29.5	3.91	33.1	4.45	36.1	4.68
		12	18.7	2.42	22.3	2.92	25.9	3.45	27.7	3.71	29.5	3.98	33.1	4.53	35.6	4.65
		14	18.7	2.46	22.3	2.98	25.9	3.51	27.7	3.78	29.5	4.06	33.1	4.61	35.2	4.65
		16	18.7	2.51	22.3	3.03	25.9	3.58	27.7	3.85	29.5	4.13	33.1	4.79	34.7	4.90
		18	18.7	2.55	22.3	3.09	25.9	3.64	27.7	3.96	29.5	4.34	33.1	5.11	34.3	5.15
		20	18.7	2.60	22.3	3.15	25.9	3.86	27.7	4.25	29.5	4.66	33.1	5.36	33.8	5.41
		21	18.7	2.62	22.3	3.24	25.9	3.99	27.7	4.40	29.5	4.83	32.8	5.49	33.6	5.53
		23	18.7	2.74	22.3	3.47	25.9	4.28	27.7	4.72	29.5	5.18	32.4	5.74	33.1	5.78
		25	18.7	2.93	22.3	3.70	25.9	4.58	27.7	5.05	29.5	5.54	31.9	5.99	32.7	6.04
		27	18.7	3.12	22.3	3.95	25.9	4.89	27.7	5.40	29.5	5.93	31.5	6.24	32.2	6.30
		29	18.7	3.32	22.3	4.22	25.9	5.22	27.7	5.77	29.5	6.34	31.0	6.49	31.8	6.55
		31	18.7	3.53	22.3	4.49	25.9	5.57	27.7	6.16	29.5	6.69	30.6	6.75	31.3	6.81
		33	18.7	3.76	22.3	4.78	25.9	5.94	27.7	6.57	29.4	6.94	30.1	7.00	30.9	7.07
		35	18.7	3.99	22.3	5.09	25.9	6.33	27.7	7.00	28.9	7.19	29.6	7.26	30.4	7.33
		37	18.7	4.24	22.3	5.42	25.9	6.75	27.7	7.41	28.4	7.45	29.2	7.52	29.9	7.59
		39	18.7	4.50	22.3	5.76	25.9	7.18	27.6	7.67	28.0	7.70	28.7	7.78	29.5	7.86
100	250 (28.00)	10	17.0	2.16	20.3	2.59	23.6	3.05	25.2	3.28	26.8	3.52	30.1	4.00	33.4	4.49
		12	17.0	2.19	20.3	2.64	23.6	3.10	25.2	3.34	26.8	3.58	30.1	4.07	33.4	4.57
		14	17.0	2.23	20.3	2.68	23.6	3.16	25.2	3.40	26.8	3.65	30.1	4.15	33.4	4.65
		16	17.0	2.27	20.3	2.73	23.6	3.22	25.2	3.47	26.8	3.72	30.1	4.23	33.4	4.84
		18	17.0	2.31	20.3	2.78	23.6	3.28	25.2	3.53	26.8	3.79	30.1	4.47	33.4	5.11
		20	17.0	2.35	20.3	2.83	23.6	3.37	25.2	3.71	26.8	4.05	30.1	4.80	33.1	5.36
		21	17.0	2.37	20.3	2.86	23.6	3.49	25.2	3.84	26.8	4.20	30.1	4.97	32.9	5.49
		23	17.0	2.43	20.3	3.05	23.6	3.74	25.2	4.11	26.8	4.50	30.1	5.33	32.4	5.74
		25	17.0	2.59	20.3	3.25	23.6	4.00	25.2	4.40	26.8	4.81	30.1	5.71	32.0	5.99
		27	17.0	2.76	20.3	3.47	23.6	4.27	25.2	4.70	26.8	5.15	30.1	6.11	31.5	6.24
		29	17.0	2.94	20.3	3.70	23.6	4.55	25.2	5.01	26.8	5.50	30.1	6.44	31.1	6.50
		31	17.0	3.12	20.3	3.94	23.6	4.85	25.2	5.35	26.8	5.87	29.9	6.70	30.6	6.75
		33	17.0	3.32	20.3	4.19	23.6	5.17	25.2	5.70	26.8	6.26	29.5	6.95	30.2	7.01
		35	17.0	3.52	20.3	4.46	23.6	5.51	25.2	6.07	26.8	6.67	29.0	7.20	29.7	7.27
		37	17.0	3.74	20.3	4.74	23.6	5.86	25.2	6.47	26.8	7.11	28.6	7.46	29.2	7.53
		39	17.0	3.97	20.3	5.04	23.6	6.24	25.2	6.89	26.8	7.57	28.1	7.72	28.8	7.79

4TW33912-3A(3)

4 Capacity tables

4 - 1 Cooling Capacity Tables

RXYRQ10P - Correction factor for mixed connection: 0.9

TC: Total Capacity: kW; PI: Power Input: kW (compressor + outdoor fan motor)

Combination (%)	Capacity index (kW)	Outdoor air temp. °CDB	Indoor air temperature:													
			14.0 °CWB		16.0 °CWB		18.0 °CWB		19.0 °CWB		20.0 °CWB		22.0 °CWB		24.0 °CWB	
			TC	PI	TC	PI	TC	PI	TC	PI	TC	PI	TC	PI	TC	PI
90 (25.20)	225	10	15.3	1.94	18.3	2.32	21.2	2.72	22.7	2.92	24.2	3.13	27.1	3.56	30.1	3.99
		12	15.3	1.97	18.3	2.36	21.2	2.77	22.7	2.97	24.2	3.19	27.1	3.62	30.1	4.06
		14	15.3	2.01	18.3	2.40	21.2	2.81	22.7	3.03	24.2	3.25	27.1	3.69	30.1	4.14
		16	15.3	2.04	18.3	2.44	21.2	2.87	22.7	3.08	24.2	3.31	27.1	3.76	30.1	4.22
		18	15.3	2.07	18.3	2.49	21.2	2.92	22.7	3.14	24.2	3.37	27.1	3.83	30.1	4.45
		20	15.3	2.11	18.3	2.53	21.2	2.97	22.7	3.20	24.2	3.49	27.1	4.11	30.1	4.79
		21	15.3	2.13	18.3	2.56	21.2	3.03	22.7	3.31	24.2	3.62	27.1	4.26	30.1	4.96
		23	15.3	2.17	18.3	2.66	21.2	3.23	22.7	3.55	24.2	3.87	27.1	4.56	30.1	5.32
		25	15.3	2.28	18.3	2.84	21.2	3.46	22.7	3.79	24.2	4.14	27.1	4.88	30.1	5.69
		27	15.3	2.43	18.3	3.02	21.2	3.69	22.7	4.04	24.2	4.42	27.1	5.22	30.1	6.09
		29	15.3	2.58	18.3	3.22	21.2	3.93	22.7	4.31	24.2	4.72	27.1	5.58	30.1	6.44
		31	15.3	2.74	18.3	3.42	21.2	4.19	22.7	4.60	24.2	5.03	27.1	5.95	29.9	6.70
		33	15.3	2.90	18.3	3.64	21.2	4.46	22.7	4.90	24.2	5.36	27.1	6.35	29.5	6.95
		35	15.3	3.08	18.3	3.86	21.2	4.74	22.7	5.21	24.2	5.71	27.1	6.77	29.0	7.20
		37	15.3	3.27	18.3	4.10	21.2	5.04	22.7	5.55	24.2	6.08	27.1	7.21	28.6	7.46
		39	15.3	3.46	18.3	4.36	21.2	5.36	22.7	5.90	24.2	6.47	27.1	7.65	28.1	7.72
		80 (22.40)	200	10	13.6	1.74	16.2	2.06	18.8	2.40	20.2	2.57	21.5	2.75	24.1	3.12
12	13.6			1.76	16.2	2.09	18.8	2.44	20.2	2.62	21.5	2.80	24.1	3.18	26.7	3.56
14	13.6			1.79	16.2	2.13	18.8	2.48	20.2	2.67	21.5	2.85	24.1	3.24	26.7	3.63
16	13.6			1.82	16.2	2.16	18.8	2.53	20.2	2.71	21.5	2.91	24.1	3.30	26.7	3.70
18	13.6			1.85	16.2	2.20	18.8	2.57	20.2	2.76	21.5	2.96	24.1	3.36	26.7	3.77
20	13.6			1.88	16.2	2.24	18.8	2.62	20.2	2.82	21.5	3.02	24.1	3.48	26.7	4.03
21	13.6			1.89	16.2	2.26	18.8	2.64	20.2	2.84	21.5	3.08	24.1	3.60	26.7	4.17
23	13.6			1.93	16.2	2.30	18.8	2.77	20.2	3.02	21.5	3.29	24.1	3.86	26.7	4.47
25	13.6			1.99	16.2	2.45	18.8	2.96	20.2	3.23	21.5	3.51	24.1	4.12	26.7	4.78
27	13.6			2.11	16.2	2.60	18.8	3.15	20.2	3.44	21.5	3.75	24.1	4.40	26.7	5.11
29	13.6			2.24	16.2	2.77	18.8	3.35	20.2	3.67	21.5	4.00	24.1	4.70	26.7	5.46
31	13.6			2.38	16.2	2.94	18.8	3.57	20.2	3.91	21.5	4.26	24.1	5.01	26.7	5.83
33	13.6			2.52	16.2	3.12	18.8	3.80	20.2	4.16	21.5	4.53	24.1	5.34	26.7	6.21
35	13.6			2.67	16.2	3.32	18.8	4.03	20.2	4.42	21.5	4.82	24.1	5.69	26.7	6.62
37	13.6			2.83	16.2	3.52	18.8	4.28	20.2	4.70	21.5	5.13	24.1	6.06	26.7	7.06
39	13.6			2.99	16.2	3.73	18.8	4.55	20.2	4.99	21.5	5.46	24.1	6.45	26.7	7.52

4TW33912-3A(4)

NOTES - ANMERKUNGEN - Σημειώσεις - NOTAS - REMARQUES - NOTE - OPMERKINGEN - Примечания - NOTLAR

- The above table shows the average value of conditions which may occur.
Die obige Tabelle zeigt den Durchschnittswert der Bedingungen, die auftreten können.
Στον παραπάνω πίνακα αναγράφεται η μέση τιμή για συνθήκες που μπορεί να προκύψουν.
La tabla de arriba muestra el valor medio de condiciones que pueden ocurrir.
Le tableau ci-dessus donne la valeur moyenne pour des conditions qui peuvent survenir.
La tabella in alto mostra il valore delle condizioni medie che si possono riscontrare.
De tabel hierboven geeft de gemiddelde waarde aan van situaties die kunnen voorvallen.
Таблица расположенная выше показывает среднее значение условий, которые могут наступить.
Yukarıdaki tablo meydana gelebilecek koşulların ortalama değerini göstermektedir.
- Correction factor for mixed connection: 0.9. For more information refer to the selection procedure.
Korrekturfaktoren für gemischten Anschluss: 0,9. Weitere Informationen finden Sie im Auswahlverfahren.
Συντελεστής διόρθωσης για συνδυαζόμενη σύνδεση: 0,9. Για περισσότερες πληροφορίες ανατρέξτε στη διαδικασία επιλογής.
Factor de corrección para conexión combinada: 0,9. Si desea más información, consulte el procedimiento de selección.
Facteur de correction pour connexion d'unités mixtes : 0,9. Pour plus d'informations, se reporter à la procédure de sélection.
Fattore di correzione per collegamento varie unità: 0,9. Per maggiori informazioni fare riferimento alla procedura di selezione.
Correctiefactor voor gemengde aansluiting: 0,9. Zie selectieprocedure voor meer informatie.
Поправочный коэффициент для комбинированного соединения: 0,9. Подробная информация приводится в разделе порядка выбора.
Karışık bağlantı için düzeltme faktörü: 0.9. Daha fazla bilgi için, seçim prosedürüne bakın.

4 Capacity tables

4 - 1 Cooling Capacity Tables

RXYRQ10P - Correction factor for mixed connection: 0.8																
TC: Total Capacity: kW ; PI: Power Input: kW (compressor + outdoor fan motor)																
Combination (%)	Capacity index (kW)	Outdoor air temp. °CDB	Indoor air temperature:													
			14.0 °CWB		16.0 °CWB		18.0 °CWB		19.0 °CWB		20.0 °CWB		22.0 °CWB		24.0 °CWB	
			20.0 °CDB		23.0 °CDB		16.0 °CDB		27.0 °CDB		28.0 °CDB		30.0 °CDB		32.0 °CDB	
			TC	PI	TC	PI	TC	PI	TC	PI	TC	PI	TC	PI	TC	PI
130	325 (36.40)	10	19.7	2.44	23.4	2.94	27.2	3.44	29.1	3.70	31.0	3.95	34.8	4.45	37.5	4.36
		12	19.7	2.48	23.4	2.99	27.2	3.50	29.1	3.76	31.0	4.02	34.8	4.53	37.0	4.47
		14	19.7	2.53	23.4	3.04	27.2	3.56	29.1	3.83	31.0	4.09	34.8	4.68	36.6	4.72
		16	19.7	2.57	23.4	3.09	27.2	3.63	29.1	3.95	31.0	4.33	34.8	4.93	36.1	4.98
		18	19.7	2.62	23.4	3.15	27.2	3.86	29.1	4.25	31.0	4.67	34.8	5.18	35.7	5.23
		20	19.7	2.66	23.4	3.35	27.2	4.14	29.1	4.57	31.0	5.02	34.3	5.44	35.2	5.49
		21	19.7	2.74	23.4	3.47	27.2	4.29	29.1	4.73	31.0	5.20	34.1	5.56	35.0	5.62
		23	19.7	2.92	23.4	3.71	27.2	4.59	29.1	5.07	31.0	5.57	33.6	5.82	34.5	5.88
		25	19.7	3.12	23.4	3.97	27.2	4.92	29.1	5.43	31.0	5.97	33.2	6.07	34.1	6.14
		27	19.7	3.33	23.4	4.24	27.2	5.26	29.1	5.81	31.0	6.27	32.7	6.33	33.6	6.40
		29	19.7	3.55	23.4	4.52	27.2	5.61	29.1	6.21	31.0	6.52	32.3	6.59	33.2	6.66
		31	19.7	3.77	23.4	4.82	27.2	5.99	29.1	6.63	30.9	6.78	31.8	6.85	32.7	6.93
33	19.7	4.01	23.4	5.13	27.2	6.39	29.1	7.00	30.5	7.04	31.4	7.11	32.2	7.19		
35	19.7	4.27	23.4	5.47	27.2	6.82	29.1	7.25	30.0	7.30	30.9	7.38	31.8	7.46		
37	19.7	4.54	23.4	5.82	27.2	7.26	29.1	7.51	29.6	7.56	30.4	7.64	31.3	7.73		
39	19.7	4.82	23.4	6.19	27.2	7.73	28.7	7.77	29.1	7.82	30.0	7.91	30.9	8.00		
120	300 (33.60)	10	18.1	2.25	21.6	2.70	25.1	3.16	26.9	3.40	28.6	3.63	32.1	4.10	35.6	4.52
		12	18.1	2.29	21.6	2.75	25.1	3.22	26.9	3.45	28.6	3.69	32.1	4.17	35.6	4.49
		14	18.1	2.33	21.6	2.79	25.1	3.27	26.9	3.52	28.6	3.76	32.1	4.24	35.6	4.69
		16	18.1	2.37	21.6	2.84	25.1	3.33	26.9	3.58	28.6	3.85	32.1	4.57	35.4	4.94
		18	18.1	2.41	21.6	2.89	25.1	3.44	26.9	3.79	28.6	4.15	32.1	4.92	35.0	5.19
		20	18.1	2.45	21.6	3.00	25.1	3.69	26.9	4.06	28.6	4.45	32.1	5.29	34.5	5.45
		21	18.1	2.47	21.6	3.11	25.1	3.82	26.9	4.21	28.6	4.61	32.1	5.48	34.3	5.57
		23	18.1	2.64	21.6	3.32	25.1	4.09	26.9	4.51	28.6	4.95	32.1	5.78	33.8	5.83
		25	18.1	2.81	21.6	3.55	25.1	4.38	26.9	4.83	28.6	5.29	32.1	6.03	33.4	6.09
		27	18.1	3.00	21.6	3.79	25.1	4.68	26.9	5.16	28.6	5.66	32.1	6.29	32.9	6.35
		29	18.1	3.19	21.6	4.04	25.1	4.99	26.9	5.51	28.6	6.05	31.6	6.54	32.5	6.61
		31	18.1	3.39	21.6	4.30	25.1	5.33	26.9	5.88	28.6	6.46	31.2	6.80	32.0	6.87
33	18.1	3.61	21.6	4.58	25.1	5.68	26.9	6.27	28.6	6.89	30.7	7.06	31.5	7.13		
35	18.1	3.83	21.6	4.88	25.1	6.05	26.9	6.69	28.6	7.24	30.3	7.32	31.1	7.40		
37	18.1	4.07	21.6	5.19	25.1	6.44	26.9	7.12	28.6	7.50	29.8	7.58	30.6	7.66		
39	18.1	4.32	21.6	5.52	25.1	6.86	26.9	7.59	28.5	7.76	29.4	7.85	30.2	7.93		
110	275 (30.80)	10	16.6	2.07	19.8	2.47	23.0	2.88	24.6	3.10	26.2	3.31	29.4	3.74	32.7	4.17
		12	16.6	2.10	19.8	2.51	23.0	2.93	24.6	3.15	26.2	3.37	29.4	3.81	32.7	4.24
		14	16.6	2.13	19.8	2.55	23.0	2.98	24.6	3.21	26.2	3.43	29.4	3.87	32.7	4.34
		16	16.6	2.17	19.8	2.60	23.0	3.04	24.6	3.26	26.2	3.49	29.4	4.02	32.7	4.68
		18	16.6	2.21	19.8	2.64	23.0	3.09	24.6	3.35	26.2	3.66	29.4	4.32	32.7	5.04
		20	16.6	2.24	19.8	2.69	23.0	3.27	24.6	3.59	26.2	3.93	29.4	4.64	32.7	5.41
		21	16.6	2.26	19.8	2.77	23.0	3.39	24.6	3.72	26.2	4.07	29.4	4.81	32.7	5.53
		23	16.6	2.37	19.8	2.96	23.0	3.62	24.6	3.98	26.2	4.35	29.4	5.16	32.7	5.78
		25	16.6	2.52	19.8	3.16	23.0	3.87	24.6	4.26	26.2	4.66	29.4	5.52	32.7	6.04
		27	16.6	2.68	19.8	3.37	23.0	4.13	24.6	4.55	26.2	4.98	29.4	5.91	32.2	6.30
		29	16.6	2.86	19.8	3.59	23.0	4.41	24.6	4.85	26.2	5.32	29.4	6.31	31.8	6.55
		31	16.6	3.03	19.8	3.82	23.0	4.70	24.6	5.18	26.2	5.67	29.4	6.74	31.3	6.81
33	16.6	3.22	19.8	4.06	23.0	5.01	24.6	5.52	26.2	6.05	29.4	7.00	30.9	7.07		
35	16.6	3.42	19.8	4.32	23.0	5.33	24.6	5.88	26.2	6.45	29.4	7.26	30.4	7.33		
37	16.6	3.63	19.8	4.59	23.0	5.67	24.6	6.26	26.2	6.87	29.2	7.52	29.9	7.59		
39	16.6	3.85	19.8	4.88	23.0	6.04	24.6	6.66	26.2	7.32	28.7	7.78	29.5	7.86		
100	250 (28.00)	10	15.1	1.88	18.0	2.24	20.9	2.61	22.4	2.80	23.9	2.99	26.8	3.38	29.7	3.77
		12	15.1	1.91	18.0	2.28	20.9	2.65	22.4	2.85	23.9	3.04	26.8	3.44	29.7	3.84
		14	15.1	1.94	18.0	2.31	20.9	2.70	22.4	2.90	23.9	3.10	26.8	3.50	29.7	3.90
		16	15.1	1.97	18.0	2.35	20.9	2.75	22.4	2.95	23.9	3.15	26.8	3.56	29.7	4.06
		18	15.1	2.01	18.0	2.39	20.9	2.80	22.4	3.00	23.9	3.21	26.8	3.76	29.7	4.37
		20	15.1	2.04	18.0	2.44	20.9	2.88	22.4	3.15	23.9	3.43	26.8	4.04	29.7	4.70
		21	15.1	2.06	18.0	2.46	20.9	2.98	22.4	3.26	23.9	3.55	26.8	4.18	29.7	4.87
		23	15.1	2.11	18.0	2.62	20.9	3.18	22.4	3.49	23.9	3.80	26.8	4.48	29.7	5.22
		25	15.1	2.25	18.0	2.79	20.9	3.40	22.4	3.72	23.9	4.07	26.8	4.80	29.7	5.59
		27	15.1	2.39	18.0	2.97	20.9	3.62	22.4	3.98	23.9	4.34	26.8	5.13	29.7	5.98
		29	15.1	2.54	18.0	3.17	20.9	3.86	22.4	4.24	23.9	4.63	26.8	5.48	29.7	6.39
		31	15.1	2.70	18.0	3.37	20.9	4.11	22.4	4.52	23.9	4.94	26.8	5.84	29.7	6.75
33	15.1	2.86	18.0	3.58	20.9	4.38	22.4	4.81	23.9	5.26	26.8	6.23	29.7	7.01		
35	15.1	3.03	18.0	3.80	20.9	4.66	22.4	5.12	23.9	5.61	26.8	6.64	29.7	7.27		
37	15.1	3.22	18.0	4.04	20.9	4.95	22.4	5.45	23.9	5.97	26.8	7.08	29.2	7.53		
39	15.1	3.41	18.0	4.29	20.9	5.27	22.4	5.80	23.9	6.35	26.8	7.54	28.8	7.79		

4TW33912-3A(5)

4 Capacity tables

4 - 1 Cooling Capacity Tables

RXYRQ10P - Correction factor for mixed connection: 0.8

TC: Total Capacity: kW ; PI: Power Input: kW (compressor + outdoor fan motor)

Combination (%)	Capacity index (kW)	Outdoor air temp. °CDB	Indoor air temperature:													
			14.0 °CWB		16.0 °CWB		18.0 °CWB		19.0 °CWB		20.0 °CWB		22.0 °CWB		24.0 °CWB	
			TC	PI	TC	PI	TC	PI	TC	PI	TC	PI	TC	PI	TC	PI
90	225 (25.20)	10	13.6	1.71	16.2	2.02	18.8	2.34	20.2	2.51	21.5	2.68	24.1	3.02	26.7	3.37
		12	13.6	1.73	16.2	2.05	18.8	2.38	20.2	2.55	21.5	2.72	24.1	3.08	26.7	3.43
		14	13.6	1.76	16.2	2.08	18.8	2.42	20.2	2.59	21.5	2.77	24.1	3.13	26.7	3.49
		16	13.6	1.79	16.2	2.12	18.8	2.46	20.2	2.64	21.5	2.82	24.1	3.19	26.7	3.56
		18	13.6	1.82	16.2	2.15	18.8	2.51	20.2	2.69	21.5	2.87	24.1	3.24	26.7	3.75
		20	13.6	1.84	16.2	2.19	18.8	2.55	20.2	2.74	21.5	2.97	24.1	3.48	26.7	4.03
		21	13.6	1.86	16.2	2.21	18.8	2.59	20.2	2.83	21.5	3.08	24.1	3.60	26.7	4.17
		23	13.6	1.89	16.2	2.30	18.8	2.77	20.2	3.02	21.5	3.29	24.1	3.86	26.7	4.47
		25	13.6	1.99	16.2	2.45	18.8	2.96	20.2	3.23	21.5	3.51	24.1	4.12	26.7	4.78
		27	13.6	2.11	16.2	2.60	18.8	3.15	20.2	3.44	21.5	3.75	24.1	4.40	26.7	5.11
		29	13.6	2.24	16.2	2.77	18.8	3.35	20.2	3.67	21.5	4.00	24.1	4.70	26.7	5.46
		31	13.6	2.38	16.2	2.94	18.8	3.57	20.2	3.91	21.5	4.26	24.1	5.01	26.7	5.83
		33	13.6	2.52	16.2	3.12	18.8	3.80	20.2	4.16	21.5	4.53	24.1	5.34	26.7	6.21
		35	13.6	2.67	16.2	3.32	18.8	4.03	20.2	4.42	21.5	4.82	24.1	5.69	26.7	6.62
		37	13.6	2.83	16.2	3.52	18.8	4.28	20.2	4.70	21.5	5.13	24.1	6.06	26.7	7.06
		39	13.6	2.99	16.2	3.73	18.8	4.55	20.2	4.99	21.5	5.46	24.1	6.45	26.7	7.52
80	200 (22.40)	10	12.1	1.54	14.4	1.80	16.8	2.08	17.9	2.23	19.1	2.37	21.4	2.67	23.7	2.98
		12	12.1	1.56	14.4	1.83	16.8	2.11	17.9	2.26	19.1	2.41	21.4	2.72	23.7	3.03
		14	12.1	1.58	14.4	1.86	16.8	2.15	17.9	2.30	19.1	2.45	21.4	2.76	23.7	3.08
		16	12.1	1.60	14.4	1.89	16.8	2.19	17.9	2.34	19.1	2.49	21.4	2.81	23.7	3.14
		18	12.1	1.63	14.4	1.92	16.8	2.22	17.9	2.38	19.1	2.54	21.4	2.86	23.7	3.19
		20	12.1	1.65	14.4	1.95	16.8	2.26	17.9	2.42	19.1	2.58	21.4	2.96	23.7	3.41
		21	12.1	1.67	14.4	1.97	16.8	2.28	17.9	2.44	19.1	2.63	21.4	3.07	23.7	3.53
		23	12.1	1.69	14.4	2.00	16.8	2.39	17.9	2.60	19.1	2.81	21.4	3.28	23.7	3.78
		25	12.1	1.75	14.4	2.13	16.8	2.54	17.9	2.77	19.1	3.00	21.4	3.50	23.7	4.04
		27	12.1	1.85	14.4	2.26	16.8	2.71	17.9	2.95	19.1	3.20	21.4	3.74	23.7	4.31
		29	12.1	1.97	14.4	2.40	16.8	2.88	17.9	3.14	19.1	3.41	21.4	3.98	23.7	4.60
		31	12.1	2.08	14.4	2.55	16.8	3.06	17.9	3.34	19.1	3.63	21.4	4.24	23.7	4.91
		33	12.1	2.20	14.4	2.70	16.8	3.25	17.9	3.55	19.1	3.86	21.4	4.52	23.7	5.23
		35	12.1	2.33	14.4	2.86	16.8	3.45	17.9	3.77	19.1	4.10	21.4	4.81	23.7	5.57
		37	12.1	2.47	14.4	3.04	16.8	3.67	17.9	4.00	19.1	4.36	21.4	5.11	23.7	5.93
		39	12.1	2.61	14.4	3.21	16.8	3.89	17.9	4.25	19.1	4.63	21.4	5.44	23.7	6.31

4TW33912-3A(6)

NOTES - ANMERKUNGEN - Σημειώσεις - NOTAS - REMARQUES - NOTE - OPMERKINGEN - Примечания - NOTLAR

- The above table shows the average value of conditions which may occur.
Die obige Tabelle zeigt den Durchschnittswert der Bedingungen, die auftreten können.
Στον παραπάνω πίνακα αναγράφεται η μέση τιμή για συνθήκες που μπορεί να προκύψουν.
La tabla de arriba muestra el valor medio de condiciones que pueden ocurrir.
Le tableau ci-dessus donne la valeur moyenne pour des conditions qui peuvent survenir.
La tabella in alto mostra il valore delle condizioni medie che si possono riscontrare.
De tabel hierboven geeft de gemiddelde waarde aan van situaties die kunnen voorvallen.
Таблица расположенная выше показывает среднее значение условий, которые могут наступить.
Yukarıdaki tablo meydana gelebilecek koşulların ortalama değerini göstermektedir.
- Correction factor for mixed connection: 0.8. For more information refer to the selection procedure.
Korrekturfaktoren für gemischten Anschluss: 0,8. Weitere Informationen finden Sie im Auswahlverfahren.
Συντελεστής διόρθωσης για συνδυαζόμενη σύνδεση: 0,8. Για περισσότερες πληροφορίες ανατρέξτε στη διαδικασία επιλογής.
Factor de corrección para conexión combinada: 0,8. Si desea más información, consulte el procedimiento de selección.
Facteur de correction pour connexion d'unités mixtes : 0,8. Pour plus d'informations, se reporter à la procédure de sélection.
Fattore di correzione per collegamento varie unità: 0,8. Per maggiori informazioni fare riferimento alla procedura di selezione.
Correctiefactor voor gemengde aansluiting: 0,8. Zie selectieprocedure voor meer informatie.
Поправочный коэффициент для комбинированного соединения: 0,8. Подробная информация приводится в разделе порядка выбора.
Karışık bağlantı için düzeltme faktörü: 0,8. Daha fazla bilgi için, seçim prosedürüne bakın.

4 Capacity tables

4 - 1 Cooling Capacity Tables

RXYRQ10P - Correction factor for mixed connection: 0.7																
TC: Total Capacity: kW ; PI: Power Input: kW (compressor + outdoor fan motor)																
Combination (%)	Capacity index (kW)	Outdoor air temp. °CDB	Indoor air temperature:													
			14.0 °CWB		16.0 °CWB		18.0 °CWB		19.0 °CWB		20.0 °CWB		22.0 °CWB		24.0 °CWB	
			20.0 °CDB		23.0 °CDB		16.0 °CDB		27.0 °CDB		28.0 °CDB		30.0 °CDB		32.0 °CDB	
			TC	PI	TC	PI	TC	PI	TC	PI	TC	PI	TC	PI	TC	PI
130	325 (36.40)	10	17.2	2.08	20.5	2.47	23.8	2.86	25.5	3.06	27.1	3.26	30.5	3.65	33.8	4.03
		12	17.2	2.11	20.5	2.51	23.8	2.91	25.5	3.11	27.1	3.31	30.5	3.71	33.8	4.22
		14	17.2	2.14	20.5	2.55	23.8	2.96	25.5	3.16	27.1	3.37	30.5	3.91	33.8	4.56
		16	17.2	2.18	20.5	2.59	23.8	3.01	25.5	3.26	27.1	3.57	30.5	4.22	33.8	4.93
		18	17.2	2.21	20.5	2.63	23.8	3.19	25.5	3.51	27.1	3.84	30.5	4.54	33.8	5.23
		20	17.2	2.25	20.5	2.80	23.8	3.43	25.5	3.76	27.1	4.12	30.5	4.88	33.8	5.49
		21	17.2	2.31	20.5	2.89	23.8	3.55	25.5	3.90	27.1	4.27	30.5	5.06	33.8	5.62
		23	17.2	2.47	20.5	3.09	23.8	3.80	25.5	4.17	27.1	4.57	30.5	5.42	33.8	5.88
		25	17.2	2.63	20.5	3.30	23.8	4.06	25.5	4.47	27.1	4.89	30.5	5.81	33.8	6.14
		27	17.2	2.80	20.5	3.52	23.8	4.33	25.5	4.77	27.1	5.23	30.5	6.21	33.6	6.40
		29	17.2	2.98	20.5	3.75	23.8	4.62	25.5	5.09	27.1	5.59	30.5	6.59	33.2	6.66
		31	17.2	3.17	20.5	4.00	23.8	4.93	25.5	5.43	27.1	5.96	30.5	6.85	32.7	6.93
		33	17.2	3.36	20.5	4.25	23.8	5.25	25.5	5.79	27.1	6.36	30.5	7.11	32.2	7.19
		35	17.2	3.57	20.5	4.53	23.8	5.60	25.5	6.17	27.1	6.78	30.5	7.38	31.8	7.46
		37	17.2	3.79	20.5	4.81	23.8	5.96	25.5	6.58	27.1	7.23	30.4	7.64	31.3	7.73
		39	17.2	4.02	20.5	5.11	23.8	6.34	25.5	7.00	27.1	7.70	30.0	7.91	30.9	8.00
120	300 (33.60)	10	15.9	1.92	18.9	2.28	22.0	2.64	23.5	2.83	25.0	3.01	28.1	3.38	31.2	3.73
		12	15.9	1.95	18.9	2.32	22.0	2.69	23.5	2.87	25.0	3.06	28.1	3.43	31.2	3.79
		14	15.9	1.98	18.9	2.35	22.0	2.73	23.5	2.92	25.0	3.11	28.1	3.49	31.2	4.05
		16	15.9	2.02	18.9	2.39	22.0	2.78	23.5	2.97	25.0	3.19	28.1	3.75	31.2	4.37
		18	15.9	2.05	18.9	2.43	22.0	2.86	23.5	3.14	25.0	3.42	28.1	4.04	31.2	4.70
		20	15.9	2.08	18.9	2.52	22.0	3.07	23.5	3.37	25.0	3.68	28.1	4.34	31.2	5.05
		21	15.9	2.10	18.9	2.61	22.0	3.18	23.5	3.48	25.0	3.80	28.1	4.49	31.2	5.24
		23	15.9	2.24	18.9	2.79	22.0	3.40	23.5	3.73	25.0	4.07	28.1	4.81	31.2	5.62
		25	15.9	2.38	18.9	2.97	22.0	3.63	23.5	3.99	25.0	4.36	28.1	5.15	31.2	6.02
		27	15.9	2.53	18.9	3.17	22.0	3.87	23.5	4.26	25.0	4.66	28.1	5.51	31.2	6.35
		29	15.9	2.69	18.9	3.37	22.0	4.13	23.5	4.54	25.0	4.97	28.1	5.89	31.2	6.61
		31	15.9	2.86	18.9	3.59	22.0	4.40	23.5	4.84	25.0	5.30	28.1	6.29	31.2	6.87
		33	15.9	3.04	18.9	3.82	22.0	4.69	23.5	5.16	25.0	5.65	28.1	6.71	31.2	7.13
		35	15.9	3.22	18.9	4.06	22.0	4.99	23.5	5.49	25.0	6.02	28.1	7.15	31.1	7.40
		37	15.9	3.42	18.9	4.31	22.0	5.31	23.5	5.85	25.0	6.41	28.1	7.58	30.6	7.66
		39	15.9	3.63	18.9	4.58	22.0	5.65	23.5	6.22	25.0	6.83	28.1	7.85	30.2	7.93
110	275 (30.80)	10	14.6	1.78	17.4	2.09	20.2	2.42	21.6	2.59	23.0	2.76	25.8	3.10	28.6	3.43
		12	14.6	1.80	17.4	2.13	20.2	2.46	21.6	2.63	23.0	2.80	25.8	3.15	28.6	3.49
		14	14.6	1.83	17.4	2.16	20.2	2.50	21.6	2.68	23.0	2.85	25.8	3.20	28.6	3.56
		16	14.6	1.86	17.4	2.20	20.2	2.55	21.6	2.72	23.0	2.90	25.8	3.31	28.6	3.84
		18	14.6	1.89	17.4	2.23	20.2	2.59	21.6	2.79	23.0	3.04	25.8	3.56	28.6	4.13
		20	14.6	1.92	17.4	2.27	20.2	2.73	21.6	2.99	23.0	3.26	25.8	3.82	28.6	4.44
		21	14.6	1.93	17.4	2.34	20.2	2.83	21.6	3.09	23.0	3.37	25.8	3.96	28.6	4.60
		23	14.6	2.02	17.4	2.49	20.2	3.02	21.6	3.31	23.0	3.61	25.8	4.24	28.6	4.93
		25	14.6	2.15	17.4	2.66	20.2	3.23	21.6	3.53	23.0	3.85	25.8	4.54	28.6	5.28
		27	14.6	2.28	17.4	2.83	20.2	3.44	21.6	3.77	23.0	4.11	25.8	4.85	28.6	5.65
		29	14.6	2.43	17.4	3.01	20.2	3.67	21.6	4.02	23.0	4.39	25.8	5.18	28.6	6.03
		31	14.6	2.57	17.4	3.20	20.2	3.91	21.6	4.28	23.0	4.68	25.8	5.52	28.6	6.44
		33	14.6	2.73	17.4	3.40	20.2	4.16	21.6	4.56	23.0	4.98	25.8	5.89	28.6	6.87
		35	14.6	2.89	17.4	3.62	20.2	4.42	21.6	4.85	23.0	5.31	25.8	6.28	28.6	7.33
		37	14.6	3.07	17.4	3.84	20.2	4.70	21.6	5.16	23.0	5.65	25.8	6.69	28.6	7.59
		39	14.6	3.25	17.4	4.07	20.2	4.99	21.6	5.49	23.0	6.01	25.8	7.12	28.6	7.86
100	250 (28.00)	10	13.2	1.63	15.8	1.91	18.3	2.21	19.6	2.36	20.9	2.51	23.4	2.82	26.0	3.12
		12	13.2	1.65	15.8	1.94	18.3	2.24	19.6	2.40	20.9	2.55	23.4	2.86	26.0	3.17
		14	13.2	1.68	15.8	1.97	18.3	2.28	19.6	2.43	20.9	2.59	23.4	2.91	26.0	3.22
		16	13.2	1.70	15.8	2.00	18.3	2.32	19.6	2.48	20.9	2.64	23.4	2.96	26.0	3.35
		18	13.2	1.73	15.8	2.04	18.3	2.36	19.6	2.52	20.9	2.68	23.4	3.12	26.0	3.60
		20	13.2	1.76	15.8	2.07	18.3	2.42	19.6	2.64	20.9	2.86	23.4	3.35	26.0	3.87
		21	13.2	1.77	15.8	2.09	18.3	2.50	19.6	2.73	20.9	2.96	23.4	3.46	26.0	4.01
		23	13.2	1.81	15.8	2.22	18.3	2.67	19.6	2.91	20.9	3.17	23.4	3.71	26.0	4.29
		25	13.2	1.93	15.8	2.36	18.3	2.85	19.6	3.11	20.9	3.38	23.4	3.96	26.0	4.59
		27	13.2	2.05	15.8	2.52	18.3	3.04	19.6	3.32	20.9	3.61	23.4	4.23	26.0	4.91
		29	13.2	2.17	15.8	2.67	18.3	3.23	19.6	3.53	20.9	3.85	23.4	4.51	26.0	5.24
		31	13.2	2.30	15.8	2.84	18.3	3.44	19.6	3.76	20.9	4.10	23.4	4.81	26.0	5.59
		33	13.2	2.44	15.8	3.02	18.3	3.66	19.6	4.00	20.9	4.36	23.4	5.13	26.0	5.96
		35	13.2	2.58	15.8	3.20	18.3	3.88	19.6	4.25	20.9	4.64	23.4	5.46	26.0	6.35
		37	13.2	2.74	15.8	3.39	18.3	4.13	19.6	4.52	20.9	4.93	23.4	5.81	26.0	6.77
		39	13.2	2.89	15.8	3.60	18.3	4.38	19.6	4.80	20.9	5.24	23.4	6.18	26.0	7.21

4TW33912-3A(7)

4 Capacity tables

4 - 1 Cooling Capacity Tables

RXYRQ10P - Correction factor for mixed connection: 0.7

TC: Total Capacity: kW; PI: Power Input: kW (compressor + outdoor fan motor)

Combination (%)	Capacity index (kW)	Outdoor air temp. °CDB	Indoor air temperature:													
			14.0 °CWB		16.0 °CWB		18.0 °CWB		19.0 °CWB		20.0 °CWB		22.0 °CWB		24.0 °CWB	
			TC	PI	TC	PI	TC	PI	TC	PI	TC	PI	TC	PI	TC	PI
90	225 (25.20)	10	10,2	1,29	12,2	1,48	14,1	1,68	15,1	1,78	16,1	1,88	18,1	2,09	20,0	2,30
		12	10,2	1,30	12,2	1,50	14,1	1,70	15,1	1,80	16,1	1,91	18,1	2,12	20,0	2,33
		14	10,2	1,32	12,2	1,52	14,1	1,73	15,1	1,83	16,1	1,94	18,1	2,15	20,0	2,37
		16	10,2	1,34	12,2	1,54	14,1	1,75	15,1	1,86	16,1	1,97	18,1	2,19	20,0	2,41
		18	10,2	1,35	12,2	1,56	14,1	1,78	15,1	1,89	16,1	2,00	18,1	2,22	20,0	2,53
		20	10,2	1,37	12,2	1,58	14,1	1,80	15,1	1,92	16,1	2,06	18,1	2,38	20,0	2,71
		21	10,2	1,38	12,2	1,60	14,1	1,83	15,1	1,98	16,1	2,13	18,1	2,46	20,0	2,81
		23	10,2	1,40	12,2	1,65	14,1	1,95	15,1	2,11	16,1	2,27	18,1	2,62	20,0	3,00
		25	10,2	1,47	12,2	1,76	14,1	2,08	15,1	2,25	16,1	2,42	18,1	2,80	20,0	3,20
		27	10,2	1,56	12,2	1,87	14,1	2,21	15,1	2,39	16,1	2,58	18,1	2,98	20,0	3,41
		29	10,2	1,65	12,2	1,98	14,1	2,34	15,1	2,54	16,1	2,74	18,1	3,17	20,0	3,64
		31	10,2	1,74	12,2	2,10	14,1	2,49	15,1	2,70	16,1	2,91	18,1	3,38	20,0	3,87
		33	10,2	1,84	12,2	2,22	14,1	2,64	15,1	2,86	16,1	3,09	18,1	3,59	20,0	4,12
		35	10,2	1,94	12,2	2,35	14,1	2,80	15,1	3,03	16,1	3,28	18,1	3,81	20,0	4,38
		37	10,2	2,05	12,2	2,48	14,1	2,96	15,1	3,22	16,1	3,48	18,1	4,05	20,0	4,66
		39	10,2	2,16	12,2	2,63	14,1	3,14	15,1	3,41	16,1	3,69	18,1	4,30	20,0	4,95
80	200 (22.40)	10	9,1	1,18	10,8	1,34	12,6	1,52	13,4	1,61	14,3	1,70	16,1	1,88	17,8	2,06
		12	9,1	1,19	10,8	1,36	12,6	1,54	13,4	1,63	14,3	1,72	16,1	1,90	17,8	2,09
		14	9,1	1,21	10,8	1,38	12,6	1,56	13,4	1,65	14,3	1,74	16,1	1,93	17,8	2,12
		16	9,1	1,22	10,8	1,40	12,6	1,58	13,4	1,68	14,3	1,77	16,1	1,96	17,8	2,16
		18	9,1	1,24	10,8	1,42	12,6	1,60	13,4	1,70	14,3	1,80	16,1	1,99	17,8	2,19
		20	9,1	1,25	10,8	1,44	12,6	1,63	13,4	1,73	14,3	1,82	16,1	2,06	17,8	2,33
		21	9,1	1,26	10,8	1,45	12,6	1,64	13,4	1,74	14,3	1,86	16,1	2,13	17,8	2,41
		23	9,1	1,28	10,8	1,47	12,6	1,71	13,4	1,84	14,3	1,98	16,1	2,27	17,8	2,58
		25	9,1	1,31	10,8	1,56	12,6	1,82	13,4	1,96	14,3	2,11	16,1	2,42	17,8	2,75
		27	9,1	1,39	10,8	1,65	12,6	1,93	13,4	2,08	14,3	2,24	16,1	2,57	17,8	2,93
		29	9,1	1,47	10,8	1,75	12,6	2,05	13,4	2,21	14,3	2,38	16,1	2,73	17,8	3,12
		31	9,1	1,55	10,8	1,85	12,6	2,17	13,4	2,35	14,3	2,52	16,1	2,90	17,8	3,31
		33	9,1	1,64	10,8	1,95	12,6	2,30	13,4	2,49	14,3	2,68	16,1	3,08	17,8	3,52
		35	9,1	1,73	10,8	2,07	12,6	2,44	13,4	2,63	14,3	2,84	16,1	3,27	17,8	3,74
		37	9,1	1,82	10,8	2,18	12,6	2,58	13,4	2,79	14,3	3,01	16,1	3,47	17,8	3,97
		39	9,1	1,92	10,8	2,30	12,6	2,73	13,4	2,95	14,3	3,18	16,1	3,68	17,8	4,22

4TW33912-3A(8)

NOTES - ANMERKUNGEN - Σημειώσεις - NOTAS - REMARQUES - NOTE - OPMERKINGEN - Примечания - NOTLAR

- The above table shows the average value of conditions which may occur.
Die obige Tabelle zeigt den Durchschnittswert der Bedingungen, die auftreten können.
Στον παραπάνω πίνακα αναγράφεται η μέση τιμή για συνθήκες που μπορεί να προκύψουν.
La tabla de arriba muestra el valor medio de condiciones que pueden ocurrir.
Le tableau ci-dessus donne la valeur moyenne pour des conditions qui peuvent survenir.
La tabella in alto mostra il valore delle condizioni medie che si possono riscontrare.
De tabel hierboven geeft de gemiddelde waarde aan van situaties die kunnen voorvallen.
Таблица расположенная выше показывает среднее значение условий, которые могут наступить.
Yukarıdaki tablo meydana gelebilecek koşulların ortalama değerini göstermektedir.
- Correction factor for mixed connection: 0.7. For more information refer to the selection procedure.
Korrekturfaktoren für gemischten Anschluss: 0,7. Weitere Informationen finden Sie im Auswahlverfahren.
Συντελεστής διόρθωσης για συνδυαζόμενη σύνδεση: 0,7. Για περισσότερες πληροφορίες ανατρέξτε στη διαδικασία επιλογής.
Factor de corrección para conexión combinada: 0,7. Si desea más información, consulte el procedimiento de selección.
Facteur de correction pour connexion d'unités mixtes : 0,7. Pour plus d'informations, se reporter à la procédure de sélection.
Fattore di correzione per collegamento varie unità: 0,7. Per maggiori informazioni fare riferimento alla procedura di selezione.
Correctiefactor voor gemengde aansluiting: 0,7. Zie selectieprocedure voor meer informatie.
Поправочный коэффициент для комбинированного соединения: 0,7. Подробная информация приводится в разделе порядка выбора.
Karışık bağlantı için düzeltme faktörü: 0.7. Daha fazla bilgi için, seçim prosedürüne bakın.

4 Capacity tables

4 - 1 Cooling Capacity Tables

RXYRQ10P - Correction factor for mixed connection: 0.6																
TC: Total Capacity: kW ; PI: Power Input: kW (compressor + outdoor fan motor)																
Combination (%)	Capacity index (kW)	Outdoor air temp. °CDB	Indoor air temperature:													
			14.0 °CWB		16.0 °CWB		18.0 °CWB		19.0 °CWB		20.0 °CWB		22.0 °CWB		24.0 °CWB	
			20.0 °CDB		23.0 °CDB		16.0 °CDB		27.0 °CDB		28.0 °CDB		30.0 °CDB		32.0 °CDB	
		TC		PI		TC		PI		TC		PI		TC		PI
130	325 (36.40)	10	14.7	1.74	17.6	2.04	20.4	2.34	21.8	2.49	23.3	2.64	26.1	2.93	28.9	3.21
		12	14.7	1.76	17.6	2.07	20.4	2.37	21.8	2.53	23.3	2.68	26.1	2.97	28.9	3.36
		14	14.7	1.79	17.6	2.10	20.4	2.41	21.8	2.57	23.3	2.72	26.1	3.13	28.9	3.63
		16	14.7	1.82	17.6	2.13	20.4	2.45	21.8	2.64	23.3	2.88	26.1	3.38	28.9	3.91
		18	14.7	1.84	17.6	2.16	20.4	2.60	21.8	2.84	23.3	3.09	26.1	3.63	28.9	4.21
		20	14.7	1.87	17.6	2.30	20.4	2.78	21.8	3.04	23.3	3.31	26.1	3.90	28.9	4.53
		21	14.7	1.92	17.6	2.37	20.4	2.88	21.8	3.15	23.3	3.43	26.1	4.03	28.9	4.69
		23	14.7	2.05	17.6	2.53	20.4	3.08	21.8	3.37	23.3	3.67	26.1	4.32	28.9	5.03
		25	14.7	2.18	17.6	2.70	20.4	3.28	21.8	3.60	23.3	3.92	26.1	4.62	28.9	5.38
		27	14.7	2.32	17.6	2.88	20.4	3.50	21.8	3.84	23.3	4.19	26.1	4.94	28.9	5.76
		29	14.7	2.46	17.6	3.06	20.4	3.73	21.8	4.09	23.3	4.47	26.1	5.28	28.9	6.15
		31	14.7	2.61	17.6	3.26	20.4	3.97	21.8	4.36	23.3	4.77	26.1	5.63	28.9	6.57
		33	14.7	2.77	17.6	3.46	20.4	4.23	21.8	4.64	23.3	5.08	26.1	6.00	28.9	7.01
		35	14.7	2.94	17.6	3.68	20.4	4.50	21.8	4.94	23.3	5.41	26.1	6.40	28.9	7.46
		37	14.7	3.12	17.6	3.90	20.4	4.78	21.8	5.26	23.3	5.75	26.1	6.82	28.9	7.73
		39	14.7	3.30	17.6	4.14	20.4	5.08	21.8	5.59	23.3	6.12	26.1	7.26	28.9	8.00
		120	300 (33.60)	10	13.6	1.62	16.2	1.89	18.8	2.17	20.2	2.31	21.5	2.45	24.1	2.73
12	13.6			1.65	16.2	1.92	18.8	2.20	20.2	2.35	21.5	2.49	24.1	2.77	26.7	3.04
14	13.6			1.67	16.2	1.95	18.8	2.24	20.2	2.38	21.5	2.53	24.1	2.81	26.7	3.24
16	13.6			1.69	16.2	1.98	18.8	2.27	20.2	2.42	21.5	2.58	24.1	3.02	26.7	3.49
18	13.6			1.72	16.2	2.01	18.8	2.34	20.2	2.55	21.5	2.77	24.1	3.24	26.7	3.75
20	13.6			1.74	16.2	2.08	18.8	2.51	20.2	2.73	21.5	2.97	24.1	3.48	26.7	4.03
21	13.6			1.76	16.2	2.15	18.8	2.59	20.2	2.83	21.5	3.08	24.1	3.60	26.7	4.17
23	13.6			1.87	16.2	2.30	18.8	2.77	20.2	3.02	21.5	3.29	24.1	3.86	26.7	4.47
25	13.6			1.99	16.2	2.45	18.8	2.96	20.2	3.23	21.5	3.51	24.1	4.12	26.7	4.78
27	13.6			2.11	16.2	2.60	18.8	3.15	20.2	3.44	21.5	3.75	24.1	4.40	26.7	5.11
29	13.6			2.24	16.2	2.77	18.8	3.35	20.2	3.67	21.5	4.00	24.1	4.70	26.7	5.46
31	13.6			2.38	16.2	2.94	18.8	3.57	20.2	3.91	21.5	4.26	24.1	5.01	26.7	5.83
33	13.6			2.52	16.2	3.12	18.8	3.80	20.2	4.16	21.5	4.53	24.1	5.34	26.7	6.21
35	13.6			2.67	16.2	3.32	18.8	4.03	20.2	4.42	21.5	4.82	24.1	5.69	26.7	6.62
37	13.6			2.83	16.2	3.52	18.8	4.28	20.2	4.70	21.5	5.13	24.1	6.06	26.7	7.06
39	13.6			2.99	16.2	3.73	18.8	4.55	20.2	4.99	21.5	5.46	24.1	6.45	26.7	7.52
110	275 (30.80)			10	12.5	1.51	14.9	1.75	17.3	2.01	18.5	2.13	19.7	2.26	22.1	2.52
		12	12.5	1.53	14.9	1.78	17.3	2.04	18.5	2.16	19.7	2.29	22.1	2.55	24.5	2.81
		14	12.5	1.55	14.9	1.80	17.3	2.07	18.5	2.20	19.7	2.33	22.1	2.59	24.5	2.87
		16	12.5	1.57	14.9	1.83	17.3	2.10	18.5	2.23	19.7	2.37	22.1	2.68	24.5	3.09
		18	12.5	1.59	14.9	1.86	17.3	2.13	18.5	2.28	19.7	2.47	22.1	2.88	24.5	3.32
		20	12.5	1.62	14.9	1.89	17.3	2.25	18.5	2.44	19.7	2.65	22.1	3.09	24.5	3.56
		21	12.5	1.63	14.9	1.94	17.3	2.32	18.5	2.53	19.7	2.74	22.1	3.20	24.5	3.69
		23	12.5	1.70	14.9	2.07	17.3	2.48	18.5	2.70	19.7	2.93	22.1	3.42	24.5	3.95
		25	12.5	1.81	14.9	2.20	17.3	2.64	18.5	2.88	19.7	3.13	22.1	3.65	24.5	4.22
		27	12.5	1.92	14.9	2.34	17.3	2.82	18.5	3.07	19.7	3.33	22.1	3.90	24.5	4.51
		29	12.5	2.03	14.9	2.49	17.3	3.00	18.5	3.27	19.7	3.55	22.1	4.16	24.5	4.81
		31	12.5	2.15	14.9	2.64	17.3	3.19	18.5	3.48	19.7	3.78	22.1	4.43	24.5	5.13
		33	12.5	2.28	14.9	2.80	17.3	3.39	18.5	3.70	19.7	4.02	22.1	4.72	24.5	5.47
		35	12.5	2.41	14.9	2.97	17.3	3.59	18.5	3.93	19.7	4.28	22.1	5.02	24.5	5.82
		37	12.5	2.55	14.9	3.15	17.3	3.82	18.5	4.17	19.7	4.55	22.1	5.34	24.5	6.20
		39	12.5	2.70	14.9	3.34	17.3	4.05	18.5	4.43	19.7	4.83	22.1	5.68	24.5	6.60
		100	250 (28.00)	10	11.3	1.40	13.5	1.61	15.7	1.84	16.8	1.95	17.9	2.07	20.1	2.30
12	11.3			1.41	13.5	1.64	15.7	1.87	16.8	1.98	17.9	2.10	20.1	2.34	22.3	2.57
14	11.3			1.43	13.5	1.66	15.7	1.89	16.8	2.01	17.9	2.13	20.1	2.37	22.3	2.61
16	11.3			1.45	13.5	1.68	15.7	1.92	16.8	2.04	17.9	2.17	20.1	2.41	22.3	2.71
18	11.3			1.47	13.5	1.71	15.7	1.95	16.8	2.08	17.9	2.20	20.1	2.54	22.3	2.91
20	11.3			1.49	13.5	1.74	15.7	2.00	16.8	2.17	17.9	2.35	20.1	2.72	22.3	3.12
21	11.3			1.50	13.5	1.75	15.7	2.07	16.8	2.24	17.9	2.43	20.1	2.81	22.3	3.23
23	11.3			1.54	13.5	1.86	15.7	2.21	16.8	2.40	17.9	2.59	20.1	3.01	22.3	3.46
25	11.3			1.63	13.5	1.97	15.7	2.35	16.8	2.55	17.9	2.76	20.1	3.21	22.3	3.69
27	11.3			1.73	13.5	2.10	15.7	2.50	16.8	2.72	17.9	2.94	20.1	3.42	22.3	3.94
29	11.3			1.83	13.5	2.23	15.7	2.66	16.8	2.89	17.9	3.13	20.1	3.65	22.3	4.20
31	11.3			1.94	13.5	2.36	15.7	2.83	16.8	3.07	17.9	3.33	20.1	3.88	22.3	4.48
33	11.3			2.05	13.5	2.50	15.7	3.00	16.8	3.27	17.9	3.54	20.1	4.13	22.3	4.77
35	11.3			2.17	13.5	2.65	15.7	3.18	16.8	3.47	17.9	3.76	20.1	4.39	22.3	5.08
37	11.3			2.30	13.5	2.81	15.7	3.37	16.8	3.68	17.9	4.00	20.1	4.67	22.3	5.40
39	11.3			2.43	13.5	2.97	15.7	3.58	16.8	3.90	17.9	4.24	20.1	4.96	22.3	5.75

4TW33912-3A(9)

4 Capacity tables

4 - 1 Cooling Capacity Tables

RXYRQ10P - Correction factor for mixed connection: 0.6

TC: Total Capacity: kW ; PI: Power Input: kW (compressor + outdoor fan motor)

Combination (%)	Capacity index (kW)	Outdoor air temp. °CDB	Indoor air temperature:															
			14.0 °CWB		16.0 °CWB		18.0 °CWB		19.0 °CWB		20.0 °CWB		22.0 °CWB		24.0 °CWB			
			20.0 °CDB		23.0 °CDB		16.0 °CDB		27.0 °CDB		28.0 °CDB		30.0 °CDB		32.0 °CDB			
			TC	PI	TC	PI	TC	PI	TC	PI	TC	PI	TC	PI	TC	PI		
90	225 (25.20)	10	10,2	1,29	12,2	1,48	14,1	1,68	15,1	1,78	16,1	1,88	18,1	2,09	20,0	2,30		
		12	10,2	1,30	12,2	1,50	14,1	1,70	15,1	1,80	16,1	1,91	18,1	2,12	20,0	2,33		
		14	10,2	1,32	12,2	1,52	14,1	1,73	15,1	1,83	16,1	1,94	18,1	2,15	20,0	2,37		
		16	10,2	1,34	12,2	1,54	14,1	1,75	15,1	1,86	16,1	1,97	18,1	2,19	20,0	2,41		
		18	10,2	1,35	12,2	1,56	14,1	1,78	15,1	1,89	16,1	2,00	18,1	2,22	20,0	2,53		
		20	10,2	1,37	12,2	1,58	14,1	1,80	15,1	1,92	16,1	2,06	18,1	2,38	20,0	2,71		
		21	10,2	1,38	12,2	1,60	14,1	1,83	15,1	1,98	16,1	2,13	18,1	2,46	20,0	2,81		
		23	10,2	1,40	12,2	1,65	14,1	1,95	15,1	2,11	16,1	2,27	18,1	2,62	20,0	3,00		
		25	10,2	1,47	12,2	1,76	14,1	2,08	15,1	2,25	16,1	2,42	18,1	2,80	20,0	3,20		
		27	10,2	1,56	12,2	1,87	14,1	2,21	15,1	2,39	16,1	2,58	18,1	2,98	20,0	3,41		
		29	10,2	1,65	12,2	1,98	14,1	2,34	15,1	2,54	16,1	2,74	18,1	3,17	20,0	3,64		
		31	10,2	1,74	12,2	2,10	14,1	2,49	15,1	2,70	16,1	2,91	18,1	3,38	20,0	3,87		
		33	10,2	1,84	12,2	2,22	14,1	2,64	15,1	2,86	16,1	3,09	18,1	3,59	20,0	4,12		
		35	10,2	1,94	12,2	2,35	14,1	2,80	15,1	3,03	16,1	3,28	18,1	3,81	20,0	4,38		
		37	10,2	2,05	12,2	2,48	14,1	2,96	15,1	3,22	16,1	3,48	18,1	4,05	20,0	4,66		
		39	10,2	2,16	12,2	2,63	14,1	3,14	15,1	3,41	16,1	3,69	18,1	4,30	20,0	4,95		
		80	200 (22.40)	10	9,1	1,18	10,8	1,34	12,6	1,52	13,4	1,61	14,3	1,70	16,1	1,88	17,8	2,06
				12	9,1	1,19	10,8	1,36	12,6	1,54	13,4	1,63	14,3	1,72	16,1	1,90	17,8	2,09
14	9,1			1,21	10,8	1,38	12,6	1,56	13,4	1,65	14,3	1,74	16,1	1,93	17,8	2,12		
16	9,1			1,22	10,8	1,40	12,6	1,58	13,4	1,68	14,3	1,77	16,1	1,96	17,8	2,16		
18	9,1			1,24	10,8	1,42	12,6	1,60	13,4	1,70	14,3	1,80	16,1	1,99	17,8	2,19		
20	9,1			1,25	10,8	1,44	12,6	1,63	13,4	1,73	14,3	1,82	16,1	2,06	17,8	2,33		
21	9,1			1,26	10,8	1,45	12,6	1,64	13,4	1,74	14,3	1,86	16,1	2,13	17,8	2,41		
23	9,1			1,28	10,8	1,47	12,6	1,71	13,4	1,84	14,3	1,98	16,1	2,27	17,8	2,58		
25	9,1			1,31	10,8	1,56	12,6	1,82	13,4	1,96	14,3	2,11	16,1	2,42	17,8	2,75		
27	9,1			1,39	10,8	1,65	12,6	1,93	13,4	2,08	14,3	2,24	16,1	2,57	17,8	2,93		
29	9,1			1,47	10,8	1,75	12,6	2,05	13,4	2,21	14,3	2,38	16,1	2,73	17,8	3,12		
31	9,1			1,55	10,8	1,85	12,6	2,17	13,4	2,35	14,3	2,52	16,1	2,90	17,8	3,31		
33	9,1			1,64	10,8	1,95	12,6	2,30	13,4	2,49	14,3	2,68	16,1	3,08	17,8	3,52		
35	9,1			1,73	10,8	2,07	12,6	2,44	13,4	2,63	14,3	2,84	16,1	3,27	17,8	3,74		
37	9,1			1,82	10,8	2,18	12,6	2,58	13,4	2,79	14,3	3,01	16,1	3,47	17,8	3,97		
39	9,1			1,92	10,8	2,30	12,6	2,73	13,4	2,95	14,3	3,18	16,1	3,68	17,8	4,22		

4TW33912-3A(10)

NOTES - ANMERKUNGEN - Σημειώσεις - NOTAS - REMARQUES - NOTE - OPMERKINGEN - Примечания - NOTLAR

- The above table shows the average value of conditions which may occur.
Die obige Tabelle zeigt den Durchschnittswert der Bedingungen, die auftreten können.
Στον παραπάνω πίνακα αναγράφεται η μέση τιμή για συνθήκες που μπορεί να προκύψουν.
La tabla de arriba muestra el valor medio de condiciones que pueden ocurrir.
Le tableau ci-dessus donne la valeur moyenne pour des conditions qui peuvent survenir.
La tabella in alto mostra il valore delle condizioni medie che si possono riscontrare.
De tabel hierboven geeft de gemiddelde waarde aan van situaties die kunnen voorvallen.
Таблица расположенная выше показывает среднее значение условий, которые могут наступить.
Yukarıdaki tablo meydana gelebilecek koşulların ortalama değerini göstermektedir.
- Correction factor for mixed connection: 0.6. For more information refer to the selection procedure.
Korrekturfaktoren für gemischten Anschluss: 0,6. Weitere Informationen finden Sie im Auswahlverfahren.
Συντελεστής διόρθωσης για συνδυαζόμενη σύνδεση: 0,6. Για περισσότερες πληροφορίες ανατρέξτε στη διαδικασία επιλογής.
Factor de corrección para conexión combinada: 0,6. Si desea más información, consulte el procedimiento de selección.
Facteur de correction pour connexion d'unités mixtes : 0,6. Pour plus d'informations, se reporter à la procédure de sélection.
Fattore di correzione per collegamento varie unità: 0,6. Per maggiori informazioni fare riferimento alla procedura di selezione.
Correctiefactor voor gemengde aansluiting: 0,6. Zie selectieprocedure voor meer informatie.
Поправочный коэффициент для комбинированного соединения: 0,6. Подробная информация приводится в разделе порядка выбора.
Karışık bağlantı için düzeltme faktörü: 0.6. Daha fazla bilgi için, seçim prosedürüne bakın.

4 Capacity tables

4 - 1 Cooling Capacity Tables

RXYRQ12P - Correction factor for mixed connection: 1.0																
TC: Total Capacity: kW ; PI: Power Input: kW (compressor + outdoor fan motor)																
Combination (%)	Capacity index (kW)	Outdoor air temp. °CDB	Indoor air temperature:													
			14.0 °CWB		16.0 °CWB		18.0 °CWB		19.0 °CWB		20.0 °CWB		22.0 °CWB		24.0 °CWB	
			20.0 °CDB		23.0 °CDB		16.0 °CDB		27.0 °CDB		28.0 °CDB		30.0 °CDB		32.0 °CDB	
			TC	PI	TC	PI	TC	PI	TC	PI	TC	PI	TC	PI	TC	PI
130	390 (43.55)	10	29.4	4.25	35.1	5.20	40.7	6.19	42.2	6.32	42.7	6.19	43.8	5.93	44.8	5.66
		12	29.4	4.33	35.1	5.30	40.7	6.30	41.6	6.29	42.2	6.15	43.2	5.89	44.3	5.80
		14	29.4	4.41	35.1	5.40	40.6	6.38	41.1	6.25	41.6	6.12	42.7	6.07	43.8	6.13
		16	29.4	4.49	35.1	5.51	40.0	6.35	40.6	6.31	41.1	6.34	42.1	6.40	43.2	6.46
		18	29.4	4.58	35.1	5.62	39.5	6.60	40.0	6.63	40.5	6.66	41.6	6.73	42.7	6.79
		20	29.4	4.67	35.1	5.98	38.9	6.92	39.5	6.95	40.0	6.99	41.1	7.06	42.1	7.12
		21	29.4	4.81	35.1	6.20	38.7	7.08	39.2	7.11	39.7	7.15	40.8	7.22	41.8	7.29
		23	29.4	5.14	35.1	6.64	38.1	7.40	38.7	7.44	39.2	7.48	40.2	7.55	41.3	7.63
		25	29.4	5.50	35.1	7.11	37.6	7.73	38.1	7.77	38.6	7.81	39.7	7.89	40.8	7.97
		27	29.4	5.88	35.1	7.61	37.0	8.05	37.6	8.09	38.1	8.14	39.2	8.22	40.2	8.31
		29	29.4	6.27	35.1	8.13	36.5	8.38	37.0	8.42	37.5	8.47	38.6	8.56	39.7	8.65
		31	29.4	6.69	34.9	8.61	35.9	8.71	36.5	8.75	37.0	8.80	38.1	8.90	39.1	8.99
33	29.4	7.13	34.3	8.93	35.4	9.03	35.9	9.08	36.5	9.13	37.5	9.24	38.6	9.34		
35	29.4	7.60	33.8	9.26	34.9	9.37	35.4	9.42	35.9	9.47	37.0	9.58	38.0	9.68		
37	29.4	8.09	33.2	9.59	34.3	9.70	34.8	9.75	35.4	9.81	36.4	9.9	37.5	10.0		
39	29.4	8.61	32.7	9.9	33.8	10.0	34.3	10.1	34.8	10.1	35.9	10.3	36.9	10.4		
120	360 (40.20)	10	27.1	3.88	32.4	4.74	37.6	5.64	40.2	6.10	42.1	6.35	43.0	6.11	44.0	5.87
		12	27.1	3.95	32.4	4.83	37.6	5.75	40.2	6.21	41.5	6.32	42.5	6.08	43.5	5.83
		14	27.1	4.03	32.4	4.92	37.6	5.86	40.2	6.33	41.0	6.29	41.9	6.04	42.9	6.08
		16	27.1	4.10	32.4	5.02	37.6	5.97	39.9	6.38	40.4	6.30	41.4	6.36	42.4	6.41
		18	27.1	4.18	32.4	5.12	37.6	6.18	39.4	6.59	39.9	6.62	40.9	6.68	41.8	6.74
		20	27.1	4.27	32.4	5.32	37.6	6.64	38.8	6.91	39.3	6.94	40.3	7.01	41.3	7.07
		21	27.1	4.31	32.4	5.51	37.6	6.88	38.6	7.07	39.1	7.11	40.0	7.17	41.0	7.24
		23	27.1	4.60	32.4	5.91	37.5	7.36	38.0	7.39	38.5	7.43	39.5	7.50	40.5	7.57
		25	27.1	4.92	32.4	6.32	37.0	7.68	37.5	7.72	38.0	7.76	38.9	7.83	39.9	7.90
		27	27.1	5.25	32.4	6.76	36.4	8.00	36.9	8.04	37.4	8.08	38.4	8.16	39.4	8.24
		29	27.1	5.60	32.4	7.22	35.9	8.33	36.4	8.37	36.9	8.41	37.9	8.49	38.8	8.58
		31	27.1	5.97	32.4	7.70	35.4	8.65	35.8	8.70	36.3	8.74	37.3	8.83	38.3	8.92
33	27.1	6.36	32.4	8.22	34.8	8.98	35.3	9.03	35.8	9.07	36.8	9.16	37.7	9.26		
35	27.1	6.77	32.4	8.76	34.3	9.31	34.8	9.36	35.2	9.40	36.2	9.50	37.2	9.60		
37	27.1	7.20	32.4	9.34	33.7	9.64	34.2	9.69	34.7	9.74	35.7	9.84	36.7	9.9		
39	27.1	7.66	32.2	9.86	33.2	10.0	33.7	10.0	34.2	10.1	35.1	10.2	36.1	10.3		
110	330 (36.85)	10	24.9	3.53	29.7	4.29	34.5	5.10	36.9	5.51	39.2	5.93	42.3	6.30	43.2	6.08
		12	24.9	3.59	29.7	4.37	34.5	5.20	36.9	5.62	39.2	6.04	41.7	6.26	42.6	6.04
		14	24.9	3.65	29.7	4.46	34.5	5.30	36.9	5.72	39.2	6.16	41.2	6.23	42.1	6.04
		16	24.9	3.72	29.7	4.54	34.5	5.40	36.9	5.84	39.2	6.28	40.6	6.31	41.5	6.36
		18	24.9	3.79	29.7	4.63	34.5	5.51	36.9	6.00	39.2	6.58	40.1	6.63	41.0	6.69
		20	24.9	3.87	29.7	4.72	34.5	5.83	36.9	6.44	38.7	6.90	39.6	6.96	40.5	7.02
		21	24.9	3.91	29.7	4.87	34.5	6.04	36.9	6.68	38.4	7.06	39.3	7.12	40.2	7.18
		23	24.9	4.09	29.7	5.21	34.5	6.48	36.9	7.16	37.8	7.38	38.7	7.45	39.6	7.51
		25	24.9	4.37	29.7	5.57	34.5	6.93	36.9	7.67	37.3	7.70	38.2	7.77	39.1	7.84
		27	24.9	4.66	29.7	5.95	34.5	7.42	36.3	7.99	36.8	8.03	37.7	8.10	38.5	8.17
		29	24.9	4.96	29.7	6.36	34.5	7.92	35.8	8.32	36.2	8.35	37.1	8.43	38.0	8.51
		31	24.9	5.29	29.7	6.78	34.5	8.46	35.2	8.64	35.7	8.68	36.6	8.76	37.5	8.84
33	24.9	5.63	29.7	7.23	34.2	8.92	34.7	8.97	35.1	9.01	36.0	9.09	36.9	9.18		
35	24.9	5.99	29.7	7.70	33.7	9.25	34.1	9.29	34.6	9.34	35.5	9.43	36.4	9.52		
37	24.9	6.36	29.7	8.20	33.1	9.57	33.6	9.62	34.0	9.67	34.9	9.76	35.8	9.86		
39	24.9	6.77	29.7	8.73	32.6	9.9	33.0	10.0	33.5	10.0	34.4	10.1	35.3	10.2		
100	300 (33.50)	10	22.6	3.18	27.0	3.86	31.3	4.57	33.5	4.94	35.7	5.31	40.0	6.07	42.3	6.28
		12	22.6	3.24	27.0	3.93	31.3	4.65	33.5	5.03	35.7	5.41	40.0	6.18	41.8	6.25
		14	22.6	3.29	27.0	4.00	31.3	4.74	33.5	5.13	35.7	5.51	40.0	6.30	41.3	6.21
		16	22.6	3.35	27.0	4.08	31.3	4.84	33.5	5.23	35.7	5.62	39.9	6.38	40.7	6.32
		18	22.6	3.42	27.0	4.15	31.3	4.93	33.5	5.33	35.7	5.73	39.4	6.59	40.2	6.64
		20	22.6	3.48	27.0	4.24	31.3	5.08	33.5	5.60	35.7	6.14	38.8	6.91	39.6	6.96
		21	22.6	3.51	27.0	4.28	31.3	5.26	33.5	5.80	35.7	6.36	38.5	7.07	39.4	7.13
		23	22.6	3.61	27.0	4.56	31.3	5.63	33.5	6.21	35.7	6.82	38.0	7.39	38.8	7.45
		25	22.6	3.85	27.0	4.88	31.3	6.03	33.5	6.65	35.7	7.31	37.4	7.72	38.3	7.78
		27	22.6	4.10	27.0	5.20	31.3	6.44	33.5	7.11	35.7	7.82	36.9	8.04	37.7	8.11
		29	22.6	4.37	27.0	5.55	31.3	6.88	33.5	7.60	35.5	8.30	36.4	8.37	37.2	8.44
		31	22.6	4.65	27.0	5.92	31.3	7.34	33.5	8.11	35.0	8.62	35.8	8.69	36.6	8.77
33	22.6	4.94	27.0	6.30	31.3	7.83	33.5	8.66	34.5	8.94	35.3	9.02	36.1	9.10		
35	22.6	5.25	27.0	6.71	31.3	8.34	33.5	9.23	33.9	9.27	34.7	9.35	35.5	9.43		
37	22.6	5.58	27.0	7.14	31.3	8.89	33.0	9.56	33.4	9.60	34.2	9.68	35.0	9.77		
39	22.6	5.93	27.0	7.59	31.3	9.47	32.4	9.88	32.8	9.9	33.6	10.0	34.4	10.1		

4TW33912-3A(1)

4 Capacity tables

4 - 1 Cooling Capacity Tables

RXYRQ12P - Correction factor for mixed connection: 1.0

TC: Total Capacity: kW ; PI: Power Input: kW (compressor + outdoor fan motor)

Combination (%)	Capacity index (kW)	Outdoor air temp. °CDB	Indoor air temperature:													
			14.0 °CWB		16.0 °CWB		18.0 °CWB		19.0 °CWB		20.0 °CWB		22.0 °CWB		24.0 °CWB	
			TC	PI	TC	PI	TC	PI	TC	PI	TC	PI	TC	PI	TC	PI
90 (30.15)	270	10	20.3	2.85	24.3	3.43	28.2	4.05	30.2	4.37	32.1	4.70	36.0	5.37	40.0	6.05
		12	20.3	2.90	24.3	3.49	28.2	4.13	30.2	4.46	32.1	4.79	36.0	5.47	40.0	6.17
		14	20.3	2.94	24.3	3.56	28.2	4.21	30.2	4.54	32.1	4.88	36.0	5.58	40.0	6.29
		16	20.3	3.00	24.3	3.62	28.2	4.29	30.2	4.63	32.1	4.98	36.0	5.69	39.9	6.39
		18	20.3	3.05	24.3	3.69	28.2	4.37	30.2	4.72	32.1	5.07	36.0	5.80	39.3	6.59
		20	20.3	3.11	24.3	3.76	28.2	4.46	30.2	4.81	32.1	5.26	36.0	6.23	38.8	6.91
		21	20.3	3.14	24.3	3.80	28.2	4.53	30.2	4.98	32.1	5.45	36.0	6.46	38.5	7.07
		23	20.3	3.20	24.3	3.96	28.2	4.85	30.2	5.33	32.1	5.84	36.0	6.92	38.0	7.39
		25	20.3	3.37	24.3	4.23	28.2	5.19	30.2	5.71	32.1	6.25	36.0	7.41	37.4	7.71
		27	20.3	3.58	24.3	4.51	28.2	5.54	30.2	6.10	32.1	6.68	36.0	7.93	36.9	8.04
		29	20.3	3.81	24.3	4.80	28.2	5.91	30.2	6.51	32.1	7.14	35.6	8.30	36.3	8.37
		31	20.3	4.05	24.3	5.11	28.2	6.30	30.2	6.94	32.1	7.62	35.1	8.63	35.8	8.69
		33	20.3	4.31	24.3	5.44	28.2	6.71	30.2	7.40	32.1	8.12	34.5	8.95	35.3	9.02
		35	20.3	4.57	24.3	5.79	28.2	7.15	30.2	7.89	32.1	8.66	34.0	9.28	34.7	9.35
		37	20.3	4.85	24.3	6.15	28.2	7.61	30.2	8.40	32.1	9.23	33.4	9.61	34.2	9.68
		39	20.3	5.15	24.3	6.54	28.2	8.10	30.2	8.94	32.1	9.83	32.9	9.9	33.6	10.0
		80	240 (26.80)	10	18.1	2.53	21.6	3.03	25.1	3.56	26.8	3.83	28.5	4.11	32.0	4.69
12	18.1			2.57	21.6	3.08	25.1	3.62	26.8	3.90	28.5	4.19	32.0	4.78	35.5	5.38
14	18.1			2.61	21.6	3.13	25.1	3.69	26.8	3.97	28.5	4.27	32.0	4.87	35.5	5.48
16	18.1			2.65	21.6	3.19	25.1	3.75	26.8	4.05	28.5	4.35	32.0	4.96	35.5	5.59
18	18.1			2.70	21.6	3.25	25.1	3.83	26.8	4.13	28.5	4.43	32.0	5.06	35.5	5.70
20	18.1			2.75	21.6	3.31	25.1	3.90	26.8	4.21	28.5	4.52	32.0	5.24	35.5	6.10
21	18.1			2.77	21.6	3.34	25.1	3.94	26.8	4.25	28.5	4.61	32.0	5.43	35.5	6.32
23	18.1			2.82	21.6	3.40	25.1	4.13	26.8	4.52	28.5	4.94	32.0	5.82	35.5	6.77
25	18.1			2.92	21.6	3.62	25.1	4.41	26.8	4.83	28.5	5.28	32.0	6.23	35.5	7.25
27	18.1			3.10	21.6	3.86	25.1	4.71	26.8	5.16	28.5	5.64	32.0	6.66	35.5	7.76
29	18.1			3.30	21.6	4.11	25.1	5.02	26.8	5.50	28.5	6.02	32.0	7.11	35.5	8.29
31	18.1			3.50	21.6	4.37	25.1	5.34	26.8	5.86	28.5	6.41	32.0	7.59	35.0	8.62
33	18.1			3.71	21.6	4.65	25.1	5.69	26.8	6.25	28.5	6.83	32.0	8.09	34.4	8.94
35	18.1			3.94	21.6	4.93	25.1	6.05	26.8	6.65	28.5	7.28	32.0	8.63	33.9	9.27
37	18.1			4.17	21.6	5.24	25.1	6.43	26.8	7.07	28.5	7.75	32.0	9.19	33.3	9.59
39	18.1			4.42	21.6	5.56	25.1	6.84	26.8	7.53	28.5	8.25	32.0	9.79	32.8	9.9

4TW33912-3A(2)

NOTES - ANMERKUNGEN - Σημειώσεις - NOTAS - REMARQUES - NOTE - OPMERKINGEN - Примечания - NOTLAR

- The above table shows the average value of conditions which may occur.
Die obige Tabelle zeigt den Durchschnittswert der Bedingungen, die auftreten können.
Στον παραπάνω πίνακα αναγράφεται η μέση τιμή για συνθήκες που μπορεί να προκύψουν.
La tabla de arriba muestra el valor medio de condiciones que pueden ocurrir.
Le tableau ci-dessus donne la valeur moyenne pour des conditions qui peuvent survenir.
La tabella in alto mostra il valore delle condizioni medie che si possono riscontrare.
De tabel hierboven geeft de gemiddelde waarde aan van situaties die kunnen voorvallen.
Таблица расположенная выше показывает среднее значение условий, которые могут наступить.
Yukarıdaki tablo meydana gelebilecek koşulların ortalama değerini göstermektedir.
- Correction factor for mixed connection: 1.0. For more information refer to the selection procedure.
Korrekturfaktoren für gemischten Anschluss: 1,0. Weitere Informationen finden Sie im Auswahlverfahren.
Συντελεστής διόρθωσης για συνδυαζόμενη σύνδεση: 1,0. Για περισσότερες πληροφορίες ανατρέξτε στη διαδικασία επιλογής.
Factor de corrección para conexión combinada: 1,0. Si desea más información, consulte el procedimiento de selección.
Facteur de correction pour connexion d'unités mixtes : 1,0. Pour plus d'informations, se reporter à la procédure de sélection.
Fattore di correzione per collegamento varie unità: 1,0. Per maggiori informazioni fare riferimento alla procedura di selezione.
Correctiefactor voor gemengde aansluiting: 1,0. Zie selectieprocedure voor meer informatie.
Поправочный коэффициент для комбинированного соединения: 1,0. Подробная информация приводится в разделе порядка выбора.
Karışık bağlantı için düzeltme faktörü: 1.0. Daha fazla bilgi için, seçim prosedürüne bakın.

4 Capacity tables

4 - 1 Cooling Capacity Tables

RXYRQ12P - Correction factor for mixed connection: 0.9																		
TC: Total Capacity: kW ; PI: Power Input: kW (compressor + outdoor fan motor)																		
Combination (%)	Capacity index (kW)	Outdoor air temp. °CDB	Indoor air temperature:															
			14.0 °CWB		16.0 °CWB		18.0 °CWB		19.0 °CWB		20.0 °CWB		22.0 °CWB		24.0 °CWB			
			20.0 °CDB		23.0 °CDB		16.0 °CDB		27.0 °CDB		28.0 °CDB		30.0 °CDB		32.0 °CDB			
			TC	PI	TC	PI	TC	PI	TC	PI	TC	PI	TC	PI	TC	PI		
130	390 (43.55)	10	26.5	3.69	31.5	4.48	36.6	5.29	39.2	5.70	41.7	6.11	43.8	5.93	44.8	5.66		
		12	26.5	3.76	31.5	4.56	36.6	5.39	39.2	5.81	41.7	6.15	43.2	5.89	44.3	5.80		
		14	26.5	3.82	31.5	4.64	36.6	5.49	39.2	5.91	41.6	6.12	42.7	6.07	43.8	6.13		
		16	26.5	3.89	31.5	4.73	36.6	5.59	39.2	6.11	41.1	6.34	42.1	6.40	43.2	6.46		
		18	26.5	3.97	31.5	4.82	36.6	5.95	39.2	6.58	40.5	6.66	41.6	6.73	42.7	6.79		
		20	26.5	4.04	31.5	5.13	36.6	6.39	39.2	6.95	40.0	6.99	41.1	7.06	42.1	7.12		
		21	26.5	4.15	31.5	5.31	36.6	6.62	39.2	7.11	39.7	7.15	40.8	7.22	41.8	7.29		
		23	26.5	4.44	31.5	5.69	36.6	7.10	38.7	7.44	39.2	7.48	40.2	7.55	41.3	7.63		
		25	26.5	4.75	31.5	6.09	36.6	7.61	38.1	7.77	38.6	7.81	39.7	7.89	40.8	7.97		
		27	26.5	5.07	31.5	6.51	36.6	8.05	37.6	8.09	38.1	8.14	39.2	8.22	40.2	8.31		
		29	26.5	5.40	31.5	6.95	36.5	8.38	37.0	8.42	37.5	8.47	38.6	8.56	39.7	8.65		
		31	26.5	5.76	31.5	7.42	35.9	8.71	36.5	8.75	37.0	8.80	38.1	8.90	39.1	8.99		
		33	26.5	6.13	31.5	7.91	35.4	9.03	35.9	9.08	36.5	9.13	37.5	9.24	38.6	9.34		
		35	26.5	6.53	31.5	8.43	34.9	9.37	35.4	9.42	35.9	9.47	37.0	9.58	38.0	9.68		
		37	26.5	6.94	31.5	8.99	34.3	9.70	34.8	9.75	35.4	9.81	36.4	9.9	37.5	10.0		
		39	26.5	7.39	31.5	9.6	33.8	10.0	34.3	10.1	34.8	10.1	35.9	10.3	36.9	10.4		
		120	360 (40.20)	10	24.4	3.39	29.1	4.10	33.8	4.84	36.2	5.22	38.5	5.60	43.0	6.11	44.0	5.87
				12	24.4	3.44	29.1	4.17	33.8	4.93	36.2	5.31	38.5	5.70	42.5	6.08	43.5	5.83
14	24.4			3.51	29.1	4.25	33.8	5.02	36.2	5.41	38.5	5.80	41.9	6.04	42.9	6.08		
16	24.4			3.57	29.1	4.33	33.8	5.11	36.2	5.51	38.5	5.95	41.4	6.36	42.4	6.41		
18	24.4			3.64	29.1	4.41	33.8	5.29	36.2	5.83	38.5	6.41	40.9	6.68	41.8	6.74		
20	24.4			3.70	29.1	4.58	33.8	5.68	36.2	6.27	38.5	6.89	40.3	7.01	41.3	7.07		
21	24.4			3.74	29.1	4.74	33.8	5.88	36.2	6.50	38.5	7.11	40.0	7.17	41.0	7.24		
23	24.4			3.99	29.1	5.08	33.8	6.30	36.2	6.97	38.5	7.43	39.5	7.50	40.5	7.57		
25	24.4			4.26	29.1	5.43	33.8	6.75	36.2	7.46	38.0	7.76	38.9	7.83	39.9	7.90		
27	24.4			4.54	29.1	5.80	33.8	7.22	36.2	7.98	37.4	8.08	38.4	8.16	39.4	8.24		
29	24.4			4.84	29.1	6.19	33.8	7.71	36.2	8.37	36.9	8.41	37.9	8.49	38.8	8.58		
31	24.4			5.16	29.1	6.60	33.8	8.23	35.8	8.70	36.3	8.74	37.3	8.83	38.3	8.92		
33	24.4			5.49	29.1	7.04	33.8	8.78	35.3	9.03	35.8	9.07	36.8	9.16	37.7	9.26		
35	24.4			5.83	29.1	7.49	33.8	9.31	34.8	9.36	35.2	9.40	36.2	9.50	37.2	9.60		
37	24.4			6.20	29.1	7.98	33.7	9.64	34.2	9.69	34.7	9.74	35.7	9.84	36.7	9.9		
39	24.4			6.59	29.1	8.49	33.2	10.0	33.7	10.0	34.2	10.1	35.1	10.2	36.1	10.3		
110	330 (36.85)			10	22.4	3.09	26.7	3.73	31.0	4.39	33.2	4.74	35.3	5.08	39.6	5.77	43.2	6.08
				12	22.4	3.14	26.7	3.79	31.0	4.47	33.2	4.82	35.3	5.17	39.6	5.88	42.6	6.04
		14	22.4	3.20	26.7	3.86	31.0	4.56	33.2	4.91	35.3	5.27	39.6	5.99	42.1	6.04		
		16	22.4	3.25	26.7	3.93	31.0	4.64	33.2	5.00	35.3	5.37	39.6	6.21	41.5	6.36		
		18	22.4	3.31	26.7	4.01	31.0	4.73	33.2	5.14	35.3	5.63	39.6	6.63	41.0	6.69		
		20	22.4	3.37	26.7	4.08	31.0	5.01	33.2	5.52	35.3	6.05	39.6	6.96	40.5	7.02		
		21	22.4	3.40	26.7	4.21	31.0	5.18	33.2	5.71	35.3	6.27	39.3	7.12	40.2	7.18		
		23	22.4	3.56	26.7	4.50	31.0	5.55	33.2	6.12	35.3	6.72	38.7	7.45	39.6	7.51		
		25	22.4	3.80	26.7	4.81	31.0	5.94	33.2	6.55	35.3	7.20	38.2	7.77	39.1	7.84		
		27	22.4	4.05	26.7	5.13	31.0	6.35	33.2	7.01	35.3	7.70	37.7	8.10	38.5	8.17		
		29	22.4	4.31	26.7	5.47	31.0	6.78	33.2	7.49	35.3	8.23	37.1	8.43	38.0	8.51		
		31	22.4	4.59	26.7	5.83	31.0	7.23	33.2	7.99	35.3	8.68	36.6	8.76	37.5	8.84		
		33	22.4	4.88	26.7	6.21	31.0	7.71	33.2	8.53	35.1	9.01	36.0	9.09	36.9	9.18		
		35	22.4	5.18	26.7	6.61	31.0	8.22	33.2	9.09	34.6	9.34	35.5	9.43	36.4	9.52		
		37	22.4	5.51	26.7	7.04	31.0	8.76	33.2	9.62	34.0	9.67	34.9	9.76	35.8	9.86		
		39	22.4	5.85	26.7	7.48	31.0	9.3	33.0	10.0	33.5	10.0	34.4	10.1	35.3	10.2		
		100	300 (33.50)	10	20.3	2.80	24.3	3.36	28.2	3.96	30.2	4.26	32.1	4.57	36.0	5.19	40.0	5.83
				12	20.3	2.85	24.3	3.42	28.2	4.03	30.2	4.34	32.1	4.65	36.0	5.29	40.0	5.93
14	20.3			2.89	24.3	3.48	28.2	4.10	30.2	4.42	32.1	4.74	36.0	5.39	40.0	6.04		
16	20.3			2.94	24.3	3.55	28.2	4.18	30.2	4.50	32.1	4.83	36.0	5.49	40.0	6.29		
18	20.3			3.00	24.3	3.61	28.2	4.26	30.2	4.58	32.1	4.92	36.0	5.80	40.0	6.64		
20	20.3			3.05	24.3	3.68	28.2	4.38	30.2	4.81	32.1	5.26	36.0	6.23	39.6	6.96		
21	20.3			3.08	24.3	3.71	28.2	4.53	30.2	4.98	32.1	5.45	36.0	6.46	39.4	7.13		
23	20.3			3.16	24.3	3.96	28.2	4.85	30.2	5.33	32.1	5.84	36.0	6.92	38.8	7.45		
25	20.3			3.37	24.3	4.23	28.2	5.19	30.2	5.71	32.1	6.25	36.0	7.41	38.3	7.78		
27	20.3			3.58	24.3	4.51	28.2	5.54	30.2	6.10	32.1	6.68	36.0	7.93	37.7	8.11		
29	20.3			3.81	24.3	4.80	28.2	5.91	30.2	6.51	32.1	7.14	36.0	8.37	37.2	8.44		
31	20.3			4.05	24.3	5.11	28.2	6.30	30.2	6.94	32.1	7.62	35.8	8.69	36.6	8.77		
33	20.3			4.31	24.3	5.44	28.2	6.71	30.2	7.40	32.1	8.12	35.3	9.02	36.1	9.10		
35	20.3			4.57	24.3	5.79	28.2	7.15	30.2	7.89	32.1	8.66	34.7	9.35	35.5	9.43		
37	20.3			4.85	24.3	6.15	28.2	7.61	30.2	8.40	32.1	9.23	34.2	9.68	35.0	9.77		
39	20.3			5.15	24.3	6.54	28.2	8.10	30.2	8.94	32.1	9.8	33.6	10.0	34.4	10.1		

4TW33912-3A(3)

4 Capacity tables

4 - 1 Cooling Capacity Tables

RXYRQ12P - Correction factor for mixed connection: 0.9

TC: Total Capacity: kW ; PI: Power Input: kW (compressor + outdoor fan motor)

Combination (%)	Capacity index (kW)	Outdoor air temp. °CDB	Indoor air temperature:													
			14.0 °CWB		16.0 °CWB		18.0 °CWB		19.0 °CWB		20.0 °CWB		22.0 °CWB		24.0 °CWB	
			TC	PI	TC	PI	TC	PI	TC	PI	TC	PI	TC	PI	TC	PI
90	270 (30.15)	10	18.3	2.52	21.8	3.01	25.4	3.53	27.1	3.79	28.9	4.07	32.4	4.62	36.0	5.18
		12	18.3	2.56	21.8	3.06	25.4	3.59	27.1	3.86	28.9	4.14	32.4	4.70	36.0	5.28
		14	18.3	2.60	21.8	3.12	25.4	3.65	27.1	3.93	28.9	4.21	32.4	4.79	36.0	5.37
		16	18.3	2.65	21.8	3.17	25.4	3.72	27.1	4.00	28.9	4.29	32.4	4.88	36.0	5.47
		18	18.3	2.69	21.8	3.23	25.4	3.79	27.1	4.08	28.9	4.37	32.4	4.97	36.0	5.78
		20	18.3	2.74	21.8	3.29	25.4	3.86	27.1	4.16	28.9	4.53	32.4	5.34	36.0	6.21
		21	18.3	2.76	21.8	3.32	25.4	3.93	27.1	4.30	28.9	4.69	32.4	5.53	36.0	6.44
		23	18.3	2.81	21.8	3.45	25.4	4.20	27.1	4.60	28.9	5.02	32.4	5.92	36.0	6.90
		25	18.3	2.96	21.8	3.68	25.4	4.49	27.1	4.92	28.9	5.37	32.4	6.34	36.0	7.39
		27	18.3	3.15	21.8	3.92	25.4	4.79	27.1	5.25	28.9	5.74	32.4	6.78	36.0	7.91
		29	18.3	3.35	21.8	4.18	25.4	5.10	27.1	5.60	28.9	6.12	32.4	7.24	36.0	8.37
		31	18.3	3.55	21.8	4.44	25.4	5.43	27.1	5.97	28.9	6.53	32.4	7.73	35.8	8.69
		33	18.3	3.77	21.8	4.72	25.4	5.78	27.1	6.36	28.9	6.96	32.4	8.24	35.3	9.02
		35	18.3	4.00	21.8	5.02	25.4	6.15	27.1	6.77	28.9	7.41	32.4	8.79	34.7	9.35
		37	18.3	4.24	21.8	5.33	25.4	6.54	27.1	7.20	28.9	7.89	32.4	9.37	34.2	9.68
		39	18.3	4.49	21.8	5.66	25.4	6.96	27.1	7.66	28.9	8.40	32.4	9.9	33.6	10.0
		80	240 (26.80)	10	16.3	2.25	19.4	2.67	22.6	3.11	24.1	3.34	25.7	3.58	28.8	4.05
12	16.3			2.29	19.4	2.71	22.6	3.17	24.1	3.40	25.7	3.64	28.8	4.13	32.0	4.63
14	16.3			2.32	19.4	2.76	22.6	3.22	24.1	3.46	25.7	3.70	28.8	4.20	32.0	4.71
16	16.3			2.36	19.4	2.81	22.6	3.28	24.1	3.52	25.7	3.77	28.8	4.28	32.0	4.80
18	16.3			2.40	19.4	2.86	22.6	3.34	24.1	3.59	25.7	3.84	28.8	4.36	32.0	4.89
20	16.3			2.44	19.4	2.91	22.6	3.40	24.1	3.66	25.7	3.91	28.8	4.52	32.0	5.23
21	16.3			2.46	19.4	2.93	22.6	3.43	24.1	3.69	25.7	3.99	28.8	4.68	32.0	5.41
23	16.3			2.50	19.4	2.99	22.6	3.60	24.1	3.93	25.7	4.27	28.8	5.01	32.0	5.80
25	16.3			2.58	19.4	3.18	22.6	3.84	24.1	4.19	25.7	4.56	28.8	5.35	32.0	6.21
27	16.3			2.74	19.4	3.38	22.6	4.09	24.1	4.47	25.7	4.87	28.8	5.72	32.0	6.64
29	16.3			2.91	19.4	3.59	22.6	4.35	24.1	4.76	25.7	5.19	28.8	6.10	32.0	7.09
31	16.3			3.09	19.4	3.82	22.6	4.63	24.1	5.07	25.7	5.53	28.8	6.50	32.0	7.56
33	16.3			3.27	19.4	4.06	22.6	4.93	24.1	5.39	25.7	5.89	28.8	6.93	32.0	8.07
35	16.3			3.47	19.4	4.30	22.6	5.24	24.1	5.74	25.7	6.26	28.8	7.38	32.0	8.60
37	16.3			3.67	19.4	4.57	22.6	5.56	24.1	6.10	25.7	6.66	28.8	7.86	32.0	9.16
39	16.3			3.89	19.4	4.84	22.6	5.91	24.1	6.48	25.7	7.08	28.8	8.37	32.0	9.8

4TW33912-3A(4)

NOTES - ANMERKUNGEN - Σημειώσεις - NOTAS - REMARQUES - NOTE - OPMERKINGEN - Примечания - NOTLAR

- The above table shows the average value of conditions which may occur.
Die obige Tabelle zeigt den Durchschnittswert der Bedingungen, die auftreten können.
Στον παραπάνω πίνακα αναγράφεται η μέση τιμή για συνθήκες που μπορεί να προκύψουν.
La tabla de arriba muestra el valor medio de condiciones que pueden ocurrir.
Le tableau ci-dessus donne la valeur moyenne pour des conditions qui peuvent survenir.
La tabella in alto mostra il valore delle condizioni medie che si possono riscontrare.
De tabel hierboven geeft de gemiddelde waarde aan van situaties die kunnen voorvallen.
Таблица расположенная выше показывает среднее значение условий, которые могут наступить.
Yukarıdaki tablo meydana gelebilecek koşulların ortalama değerini göstermektedir.
- Correction factor for mixed connection: 0.9. For more information refer to the selection procedure.
Korrekturfaktoren für gemischten Anschluss: 0,9. Weitere Informationen finden Sie im Auswahlverfahren.
Συντελεστής διόρθωσης για συνδυαζόμενη σύνδεση: 0,9. Για περισσότερες πληροφορίες ανατρέξτε στη διαδικασία επιλογής.
Factor de corrección para conexión combinada: 0,9. Si desea más información, consulte el procedimiento de selección.
Facteur de correction pour connexion d'unités mixtes : 0,9. Pour plus d'informations, se reporter à la procédure de sélection.
Fattore di correzione per collegamento varie unità: 0,9. Per maggiori informazioni fare riferimento alla procedura di selezione.
Correctiefactor voor gemengde aansluiting: 0,9. Zie selectieprocedure voor meer informatie.
Поправочный коэффициент для комбинированного соединения: 0,9. Подробная информация приводится в разделе порядка выбора.
Karışık bağlantı için düzeltme faktörü: 0.9. Daha fazla bilgi için, seçim prosedürüne bakın.

4 Capacity tables

4 - 1 Cooling Capacity Tables

RXYRQ12P - Correction factor for mixed connection: 0.8																		
TC: Total Capacity: kW ; PI: Power Input: kW (compressor + outdoor fan motor)																		
Combination (%)	Capacity index (kW)	Outdoor air temp. °CDB	Indoor air temperature:															
			14.0 °CWB		16.0 °CWB		18.0 °CWB		19.0 °CWB		20.0 °CWB		22.0 °CWB		24.0 °CWB			
			20.0 °CDB		23.0 °CDB		16.0 °CDB		27.0 °CDB		28.0 °CDB		30.0 °CDB		32.0 °CDB			
			TC	PI	TC	PI	TC	PI	TC	PI	TC	PI	TC	PI	TC	PI		
130	390 (43.55)	10	23.5	3.17	28.0	3.81	32.6	4.47	34.8	4.80	37.1	5.13	41.6	5.78	44.8	5.66		
		12	23.5	3.23	28.0	3.88	32.6	4.55	34.8	4.88	37.1	5.22	41.6	5.88	44.3	5.80		
		14	23.5	3.28	28.0	3.95	32.6	4.63	34.8	4.97	37.1	5.31	41.6	6.07	43.8	6.13		
		16	23.5	3.34	28.0	4.02	32.6	4.71	34.8	5.13	37.1	5.63	41.6	6.40	43.2	6.46		
		18	23.5	3.40	28.0	4.09	32.6	5.00	34.8	5.52	37.1	6.06	41.6	6.73	42.7	6.79		
		20	23.5	3.46	28.0	4.35	32.6	5.37	34.8	5.93	37.1	6.51	41.1	7.06	42.1	7.12		
		21	23.5	3.55	28.0	4.50	32.6	5.57	34.8	6.14	37.1	6.75	40.8	7.22	41.8	7.29		
		23	23.5	3.80	28.0	4.82	32.6	5.96	34.8	6.58	37.1	7.24	40.2	7.55	41.3	7.63		
		25	23.5	4.05	28.0	5.15	32.6	6.38	34.8	7.05	37.1	7.75	39.7	7.89	40.8	7.97		
		27	23.5	4.32	28.0	5.50	32.6	6.82	34.8	7.54	37.1	8.14	39.2	8.22	40.2	8.31		
		29	23.5	4.60	28.0	5.87	32.6	7.29	34.8	8.06	37.1	8.47	38.6	8.56	39.7	8.65		
		31	23.5	4.90	28.0	6.25	32.6	7.78	34.8	8.61	37.0	8.80	38.1	8.90	39.1	8.99		
		33	23.5	5.21	28.0	6.66	32.6	8.30	34.8	9.08	36.5	9.13	37.5	9.24	38.6	9.34		
		35	23.5	5.54	28.0	7.10	32.6	8.85	34.8	9.42	35.9	9.47	37.0	9.58	38.0	9.68		
		37	23.5	5.89	28.0	7.55	32.6	9.43	34.8	9.75	35.4	9.81	36.4	9.9	37.5	10.0		
		39	23.5	6.26	28.0	8.0	32.6	10.0	34.3	10.1	34.8	10.1	35.9	10.3	36.9	10.4		
		120	360 (40.20)	10	21.7	2.92	25.9	3.50	30.1	4.10	32.2	4.41	34.3	4.71	38.4	5.32	42.6	5.87
				12	21.7	2.97	25.9	3.56	30.1	4.18	32.2	4.49	34.3	4.80	38.4	5.41	42.6	5.83
14	21.7			3.02	25.9	3.63	30.1	4.25	32.2	4.56	34.3	4.88	38.4	5.51	42.6	6.08		
16	21.7			3.07	25.9	3.69	30.1	4.33	32.2	4.65	34.3	5.00	38.4	5.93	42.4	6.41		
18	21.7			3.13	25.9	3.76	30.1	4.47	32.2	4.91	34.3	5.38	38.4	6.39	41.8	6.74		
20	21.7			3.18	25.9	3.90	30.1	4.79	32.2	5.28	34.3	5.78	38.4	6.87	41.3	7.07		
21	21.7			3.21	25.9	4.03	30.1	4.96	32.2	5.46	34.3	5.99	38.4	7.11	41.0	7.24		
23	21.7			3.42	25.9	4.32	30.1	5.31	32.2	5.85	34.3	6.42	38.4	7.50	40.5	7.57		
25	21.7			3.65	25.9	4.61	30.1	5.68	32.2	6.26	34.3	6.87	38.4	7.83	39.9	7.90		
27	21.7			3.89	25.9	4.92	30.1	6.07	32.2	6.70	34.3	7.35	38.4	8.16	39.4	8.24		
29	21.7			4.14	25.9	5.24	30.1	6.48	32.2	7.15	34.3	7.85	37.9	8.49	38.8	8.58		
31	21.7			4.41	25.9	5.59	30.1	6.91	32.2	7.63	34.3	8.39	37.3	8.83	38.3	8.92		
33	21.7			4.68	25.9	5.95	30.1	7.37	32.2	8.14	34.3	8.95	36.8	9.16	37.7	9.26		
35	21.7			4.97	25.9	6.33	30.1	7.85	32.2	8.68	34.3	9.40	36.2	9.50	37.2	9.60		
37	21.7			5.28	25.9	6.73	30.1	8.37	32.2	9.25	34.3	9.74	35.7	9.84	36.7	9.9		
39	21.7			5.61	25.9	7.16	30.1	8.9	32.2	9.9	34.2	10.1	35.1	10.2	36.1	10.3		
110	330 (36.85)			10	19.9	2.68	23.7	3.20	27.6	3.74	29.5	4.02	31.4	4.30	35.2	4.86	39.1	5.41
				12	19.9	2.72	23.7	3.26	27.6	3.81	29.5	4.09	31.4	4.37	35.2	4.94	39.1	5.50
		14	19.9	2.77	23.7	3.31	27.6	3.87	29.5	4.16	31.4	4.45	35.2	5.03	39.1	5.63		
		16	19.9	2.82	23.7	3.37	27.6	3.94	29.5	4.24	31.4	4.53	35.2	5.21	39.1	6.08		
		18	19.9	2.86	23.7	3.43	27.6	4.02	29.5	4.34	31.4	4.75	35.2	5.61	39.1	6.55		
		20	19.9	2.91	23.7	3.49	27.6	4.25	29.5	4.66	31.4	5.10	35.2	6.03	39.1	7.02		
		21	19.9	2.94	23.7	3.59	27.6	4.39	29.5	4.83	31.4	5.28	35.2	6.24	39.1	7.18		
		23	19.9	3.07	23.7	3.84	27.6	4.70	29.5	5.17	31.4	5.65	35.2	6.69	39.1	7.51		
		25	19.9	3.27	23.7	4.10	27.6	5.03	29.5	5.53	31.4	6.05	35.2	7.17	39.1	7.84		
		27	19.9	3.48	23.7	4.37	27.6	5.37	29.5	5.90	31.4	6.46	35.2	7.67	38.5	8.17		
		29	19.9	3.71	23.7	4.66	27.6	5.72	29.5	6.30	31.4	6.90	35.2	8.20	38.0	8.51		
		31	19.9	3.94	23.7	4.96	27.6	6.10	29.5	6.72	31.4	7.37	35.2	8.75	37.5	8.84		
		33	19.9	4.18	23.7	5.28	27.6	6.50	29.5	7.16	31.4	7.86	35.2	9.09	36.9	9.18		
		35	19.9	4.44	23.7	5.61	27.6	6.92	29.5	7.63	31.4	8.37	35.2	9.43	36.4	9.52		
		37	19.9	4.71	23.7	5.96	27.6	7.37	29.5	8.12	31.4	8.92	34.9	9.76	35.8	9.86		
		39	19.9	5.00	23.7	6.34	27.6	7.8	29.5	8.6	31.4	9.5	34.4	10.1	35.3	10.2		
		100	300 (33.50)	10	18.1	2.45	21.6	2.91	25.1	3.39	26.8	3.63	28.5	3.88	32.0	4.39	35.5	4.90
				12	18.1	2.48	21.6	2.95	25.1	3.45	26.8	3.70	28.5	3.95	32.0	4.47	35.5	4.98
14	18.1			2.52	21.6	3.00	25.1	3.50	26.8	3.76	28.5	4.02	32.0	4.54	35.5	5.07		
16	18.1			2.56	21.6	3.05	25.1	3.57	26.8	3.83	28.5	4.09	32.0	4.63	35.5	5.27		
18	18.1			2.61	21.6	3.11	25.1	3.63	26.8	3.90	28.5	4.17	32.0	4.88	35.5	5.68		
20	18.1			2.65	21.6	3.16	25.1	3.73	26.8	4.09	28.5	4.46	32.0	5.24	35.5	6.10		
21	18.1			2.67	21.6	3.19	25.1	3.86	26.8	4.23	28.5	4.61	32.0	5.43	35.5	6.32		
23	18.1			2.74	21.6	3.40	25.1	4.13	26.8	4.52	28.5	4.94	32.0	5.82	35.5	6.77		
25	18.1			2.92	21.6	3.62	25.1	4.41	26.8	4.83	28.5	5.28	32.0	6.23	35.5	7.25		
27	18.1			3.10	21.6	3.86	25.1	4.71	26.8	5.16	28.5	5.64	32.0	6.66	35.5	7.76		
29	18.1			3.30	21.6	4.11	25.1	5.02	26.8	5.50	28.5	6.02	32.0	7.11	35.5	8.30		
31	18.1			3.50	21.6	4.37	25.1	5.34	26.8	5.86	28.5	6.41	32.0	7.59	35.5	8.77		
33	18.1			3.71	21.6	4.65	25.1	5.69	26.8	6.25	28.5	6.83	32.0	8.09	35.5	9.10		
35	18.1			3.94	21.6	4.93	25.1	6.05	26.8	6.65	28.5	7.28	32.0	8.63	35.5	9.43		
37	18.1			4.17	21.6	5.24	25.1	6.43	26.8	7.07	28.5	7.75	32.0	9.19	35.0	9.77		
39	18.1			4.42	21.6	5.56	25.1	6.84	26.8	7.53	28.5	8.2	32.0	9.8	34.4	10.1		

4TW33912-3A(5)

4 Capacity tables

4 - 1 Cooling Capacity Tables

RXYRQ12P - Correction factor for mixed connection: 0.8

TC: Total Capacity: kW ; PI: Power Input: kW (compressor + outdoor fan motor)

Combination (%)	Capacity index (kW)	Outdoor air temp. °CDB	Indoor air temperature:													
			14.0 °CWB		16.0 °CWB		18.0 °CWB		19.0 °CWB		20.0 °CWB		22.0 °CWB		24.0 °CWB	
			TC	PI	TC	PI	TC	PI	TC	PI	TC	PI	TC	PI	TC	PI
90 (30.15)	270	10	16.3	2.22	19.4	2.62	22.6	3.04	24.1	3.26	25.7	3.48	28.8	3.93	32.0	4.38
		12	16.3	2.25	19.4	2.66	22.6	3.09	24.1	3.31	25.7	3.54	28.8	3.99	32.0	4.46
		14	16.3	2.28	19.4	2.70	22.6	3.14	24.1	3.37	25.7	3.60	28.8	4.06	32.0	4.53
		16	16.3	2.32	19.4	2.75	22.6	3.20	24.1	3.43	25.7	3.66	28.8	4.14	32.0	4.62
		18	16.3	2.36	19.4	2.79	22.6	3.25	24.1	3.49	25.7	3.73	28.8	4.21	32.0	4.87
		20	16.3	2.40	19.4	2.84	22.6	3.31	24.1	3.55	25.7	3.86	28.8	4.52	32.0	5.23
		21	16.3	2.41	19.4	2.87	22.6	3.37	24.1	3.67	25.7	3.99	28.8	4.68	32.0	5.41
		23	16.3	2.46	19.4	2.98	22.6	3.60	24.1	3.93	25.7	4.27	28.8	5.01	32.0	5.80
		25	16.3	2.58	19.4	3.18	22.6	3.84	24.1	4.19	25.7	4.56	28.8	5.35	32.0	6.21
		27	16.3	2.74	19.4	3.38	22.6	4.09	24.1	4.47	25.7	4.87	28.8	5.72	32.0	6.64
		29	16.3	2.91	19.4	3.59	22.6	4.35	24.1	4.76	25.7	5.19	28.8	6.10	32.0	7.09
		31	16.3	3.09	19.4	3.82	22.6	4.63	24.1	5.07	25.7	5.53	28.8	6.50	32.0	7.56
		33	16.3	3.27	19.4	4.06	22.6	4.93	24.1	5.39	25.7	5.89	28.8	6.93	32.0	8.07
		35	16.3	3.47	19.4	4.30	22.6	5.24	24.1	5.74	25.7	6.26	28.8	7.38	32.0	8.60
		37	16.3	3.67	19.4	4.57	22.6	5.56	24.1	6.10	25.7	6.66	28.8	7.86	32.0	9.16
		39	16.3	3.89	19.4	4.84	22.6	5.91	24.1	6.48	25.7	7.08	28.8	8.4	32.0	9.8
		80 (26.80)	240	10	14.5	1.99	17.3	2.34	20.0	2.70	21.4	2.89	22.8	3.08	25.6	3.47
12	14.5			2.02	17.3	2.38	20.0	2.74	21.4	2.94	22.8	3.13	25.6	3.53	28.4	3.93
14	14.5			2.05	17.3	2.41	20.0	2.79	21.4	2.98	22.8	3.18	25.6	3.59	28.4	4.00
16	14.5			2.08	17.3	2.45	20.0	2.84	21.4	3.04	22.8	3.24	25.6	3.65	28.4	4.07
18	14.5			2.12	17.3	2.49	20.0	2.89	21.4	3.09	22.8	3.30	25.6	3.72	28.4	4.15
20	14.5			2.15	17.3	2.53	20.0	2.94	21.4	3.14	22.8	3.35	25.6	3.85	28.4	4.43
21	14.5			2.17	17.3	2.55	20.0	2.96	21.4	3.17	22.8	3.42	25.6	3.98	28.4	4.58
23	14.5			2.20	17.3	2.60	20.0	3.10	21.4	3.37	22.8	3.65	25.6	4.26	28.4	4.91
25	14.5			2.27	17.3	2.76	20.0	3.30	21.4	3.59	22.8	3.90	25.6	4.55	28.4	5.24
27	14.5			2.41	17.3	2.93	20.0	3.52	21.4	3.83	22.8	4.16	25.6	4.85	28.4	5.60
29	14.5			2.55	17.3	3.12	20.0	3.74	21.4	4.08	22.8	4.43	25.6	5.17	28.4	5.98
31	14.5			2.70	17.3	3.31	20.0	3.98	21.4	4.34	22.8	4.71	25.6	5.51	28.4	6.37
33	14.5			2.86	17.3	3.51	20.0	4.22	21.4	4.61	22.8	5.01	25.6	5.86	28.4	6.79
35	14.5			3.03	17.3	3.72	20.0	4.48	21.4	4.90	22.8	5.32	25.6	6.24	28.4	7.23
37	14.5			3.20	17.3	3.94	20.0	4.76	21.4	5.20	22.8	5.66	25.6	6.64	28.4	7.70
39	14.5			3.39	17.3	4.17	20.0	5.05	21.4	5.52	22.8	6.01	25.6	7.06	28.4	8.2

4TW33912-3A(6)

NOTES - ANMERKUNGEN - Σημειώσεις - NOTAS - REMARQUES - NOTE - OPMERKINGEN - Примечания - NOTLAR

- The above table shows the average value of conditions which may occur.
Die obige Tabelle zeigt den Durchschnittswert der Bedingungen, die auftreten können.
Στον παραπάνω πίνακα αναγράφεται η μέση τιμή για συνθήκες που μπορεί να προκύψουν.
La tabla de arriba muestra el valor medio de condiciones que pueden ocurrir.
Le tableau ci-dessus donne la valeur moyenne pour des conditions qui peuvent survenir.
La tabella in alto mostra il valore delle condizioni medie che si possono riscontrare.
De tabel hierboven geeft de gemiddelde waarde aan van situaties die kunnen voorvallen.
Таблица расположенная выше показывает среднее значение условий, которые могут наступить.
Yukarıdaki tablo meydana gelebilecek koşulların ortalama değerini göstermektedir.
- Correction factor for mixed connection: 0.8. For more information refer to the selection procedure.
Korrekturfaktoren für gemischten Anschluss: 0,8. Weitere Informationen finden Sie im Auswahlverfahren.
Συντελεστής διόρθωσης για συνδυαζόμενη σύνδεση: 0,8. Για περισσότερες πληροφορίες ανατρέξτε στη διαδικασία επιλογής.
Factor de corrección para conexión combinada: 0,8. Si desea más información, consulte el procedimiento de selección.
Facteur de correction pour connexion d'unités mixtes : 0,8. Pour plus d'informations, se reporter à la procédure de sélection.
Fattore di correzione per collegamento varie unità: 0,8. Per maggiori informazioni fare riferimento alla procedura di selezione.
Correctiefactor voor gemengde aansluiting: 0,8. Zie selectieprocedure voor meer informatie.
Поправочный коэффициент для комбинированного соединения: 0,8. Подробная информация приводится в разделе порядка выбора.
Karışık bağlantı için düzeltme faktörü: 0,8. Daha fazla bilgi için, seçim prosedürüne bakın.

4 Capacity tables

4 - 1 Cooling Capacity Tables

RXYRQ12P - Correction factor for mixed connection: 0.7																
TC: Total Capacity: kW ; PI: Power Input: kW (compressor + outdoor fan motor)																
Combination (%)	Capacity index (kW)	Outdoor air temp. °CDB	Indoor air temperature:													
			14.0 °CWB		16.0 °CWB		18.0 °CWB		19.0 °CWB		20.0 °CWB		22.0 °CWB		24.0 °CWB	
			20.0 °CDB		23.0 °CDB		16.0 °CDB		27.0 °CDB		28.0 °CDB		30.0 °CDB		32.0 °CDB	
			TC	PI	TC	PI	TC	PI	TC	PI	TC	PI	TC	PI	TC	PI
130	390 (43.55)	10	20.6	2.69	24.5	3.20	28.5	3.72	30.5	3.98	32.5	4.23	36.4	4.74	40.4	5.23
		12	20.6	2.74	24.5	3.25	28.5	3.78	30.5	4.04	32.5	4.30	36.4	4.81	40.4	5.48
		14	20.6	2.78	24.5	3.31	28.5	3.84	30.5	4.11	32.5	4.37	36.4	5.08	40.4	5.92
		16	20.6	2.83	24.5	3.36	28.5	3.90	30.5	4.24	32.5	4.63	36.4	5.48	40.4	6.39
		18	20.6	2.87	24.5	3.42	28.5	4.15	30.5	4.55	32.5	4.98	36.4	5.90	40.4	6.79
		20	20.6	2.92	24.5	3.63	28.5	4.45	30.5	4.89	32.5	5.35	36.4	6.34	40.4	7.12
		21	20.6	3.00	24.5	3.76	28.5	4.60	30.5	5.06	32.5	5.54	36.4	6.56	40.4	7.29
		23	20.6	3.20	24.5	4.02	28.5	4.93	30.5	5.42	32.5	5.93	36.4	7.04	40.4	7.63
		25	20.6	3.41	24.5	4.29	28.5	5.27	30.5	5.80	32.5	6.35	36.4	7.54	40.4	7.97
		27	20.6	3.63	24.5	4.57	28.5	5.63	30.5	6.19	32.5	6.79	36.4	8.07	40.2	8.31
		29	20.6	3.87	24.5	4.87	28.5	6.00	30.5	6.61	32.5	7.25	36.4	8.56	39.7	8.65
		31	20.6	4.11	24.5	5.19	28.5	6.40	30.5	7.05	32.5	7.74	36.4	8.90	39.1	8.99
		33	20.6	4.37	24.5	5.52	28.5	6.82	30.5	7.52	32.5	8.26	36.4	9.24	38.6	9.34
		35	20.6	4.64	24.5	5.87	28.5	7.26	30.5	8.01	32.5	8.80	36.4	9.58	38.0	9.68
		37	20.6	4.92	24.5	6.25	28.5	7.73	30.5	8.54	32.5	9.38	36.4	9.9	37.5	10.0
		39	20.6	5.22	24.5	6.6	28.5	8.2	30.5	9.1	32.5	10.0	35.9	10.3	36.9	10.4
		120	360 (40.20)	10	19.0	2.50	22.7	2.96	26.3	3.43	28.1	3.67	30.0	3.91	33.6	4.38
12	19.0			2.54	22.7	3.01	26.3	3.49	28.1	3.73	30.0	3.97	33.6	4.45	37.3	4.92
14	19.0			2.58	22.7	3.05	26.3	3.54	28.1	3.79	30.0	4.04	33.6	4.53	37.3	5.25
16	19.0			2.62	22.7	3.10	26.3	3.60	28.1	3.86	30.0	4.14	33.6	4.87	37.3	5.67
18	19.0			2.66	22.7	3.16	26.3	3.72	28.1	4.07	30.0	4.45	33.6	5.24	37.3	6.10
20	19.0			2.70	22.7	3.27	26.3	3.99	28.1	4.37	30.0	4.77	33.6	5.63	37.3	6.56
21	19.0			2.73	22.7	3.38	26.3	4.12	28.1	4.52	30.0	4.94	33.6	5.83	37.3	6.80
23	19.0			2.90	22.7	3.62	26.3	4.41	28.1	4.84	30.0	5.29	33.6	6.25	37.3	7.29
25	19.0			3.09	22.7	3.86	26.3	4.71	28.1	5.17	30.0	5.66	33.6	6.69	37.3	7.81
27	19.0			3.29	22.7	4.11	26.3	5.03	28.1	5.53	30.0	6.04	33.6	7.15	37.3	8.24
29	19.0			3.50	22.7	4.38	26.3	5.36	28.1	5.89	30.0	6.45	33.6	7.64	37.3	8.58
31	19.0			3.72	22.7	4.66	26.3	5.72	28.1	6.28	30.0	6.88	33.6	8.16	37.3	8.92
33	19.0			3.95	22.7	4.96	26.3	6.09	28.1	6.70	30.0	7.34	33.6	8.71	37.3	9.26
35	19.0			4.19	22.7	5.27	26.3	6.48	28.1	7.13	30.0	7.82	33.6	9.28	37.2	9.60
37	19.0			4.44	22.7	5.60	26.3	6.89	28.1	7.59	30.0	8.32	33.6	9.84	36.7	9.9
39	19.0			4.71	22.7	5.94	26.3	7.3	28.1	8.1	30.0	8.9	33.6	10.2	36.1	10.3
110	330 (36.85)			10	17.4	2.30	20.8	2.72	24.1	3.15	25.8	3.36	27.5	3.58	30.8	4.02
		12	17.4	2.34	20.8	2.76	24.1	3.20	25.8	3.42	27.5	3.64	30.8	4.09	34.2	4.53
		14	17.4	2.37	20.8	2.81	24.1	3.25	25.8	3.47	27.5	3.70	30.8	4.15	34.2	4.63
		16	17.4	2.41	20.8	2.85	24.1	3.30	25.8	3.53	27.5	3.76	30.8	4.30	34.2	4.99
		18	17.4	2.45	20.8	2.90	24.1	3.36	25.8	3.62	27.5	3.94	30.8	4.63	34.2	5.37
		20	17.4	2.49	20.8	2.95	24.1	3.55	25.8	3.88	27.5	4.23	30.8	4.97	34.2	5.76
		21	17.4	2.51	20.8	3.03	24.1	3.67	25.8	4.02	27.5	4.37	30.8	5.14	34.2	5.97
		23	17.4	2.62	20.8	3.24	24.1	3.93	25.8	4.29	27.5	4.68	30.8	5.51	34.2	6.40
		25	17.4	2.79	20.8	3.45	24.1	4.19	25.8	4.59	27.5	5.00	30.8	5.89	34.2	6.85
		27	17.4	2.96	20.8	3.68	24.1	4.47	25.8	4.90	27.5	5.34	30.8	6.29	34.2	7.33
		29	17.4	3.15	20.8	3.91	24.1	4.76	25.8	5.22	27.5	5.70	30.8	6.72	34.2	7.83
		31	17.4	3.34	20.8	4.16	24.1	5.07	25.8	5.56	27.5	6.07	30.8	7.17	34.2	8.36
		33	17.4	3.55	20.8	4.42	24.1	5.39	25.8	5.92	27.5	6.47	30.8	7.65	34.2	8.92
		35	17.4	3.76	20.8	4.69	24.1	5.74	25.8	6.30	27.5	6.89	30.8	8.15	34.2	9.52
		37	17.4	3.98	20.8	4.98	24.1	6.10	25.8	6.70	27.5	7.33	30.8	8.68	34.2	9.86
		39	17.4	4.22	20.8	5.29	24.1	6.5	25.8	7.1	27.5	7.8	30.8	9.2	34.2	10.2
		100	300 (33.50)	10	15.8	2.12	18.9	2.48	21.9	2.87	23.5	3.06	25.0	3.26	28.0	3.65
12	15.8			2.15	18.9	2.52	21.9	2.91	23.5	3.11	25.0	3.31	28.0	3.71	31.1	4.12
14	15.8			2.18	18.9	2.56	21.9	2.96	23.5	3.16	25.0	3.36	28.0	3.78	31.1	4.19
16	15.8			2.21	18.9	2.60	21.9	3.01	23.5	3.21	25.0	3.42	28.0	3.84	31.1	4.35
18	15.8			2.24	18.9	2.64	21.9	3.06	23.5	3.27	25.0	3.48	28.0	4.05	31.1	4.68
20	15.8			2.28	18.9	2.69	21.9	3.14	23.5	3.42	25.0	3.72	28.0	4.34	31.1	5.02
21	15.8			2.30	18.9	2.71	21.9	3.25	23.5	3.54	25.0	3.85	28.0	4.50	31.1	5.20
23	15.8			2.35	18.9	2.88	21.9	3.47	23.5	3.78	25.0	4.11	28.0	4.81	31.1	5.57
25	15.8			2.50	18.9	3.07	21.9	3.70	23.5	4.04	25.0	4.39	28.0	5.14	31.1	5.96
27	15.8			2.66	18.9	3.27	21.9	3.94	23.5	4.30	25.0	4.68	28.0	5.49	31.1	6.37
29	15.8			2.82	18.9	3.47	21.9	4.20	23.5	4.59	25.0	4.99	28.0	5.86	31.1	6.80
31	15.8			2.99	18.9	3.69	21.9	4.46	23.5	4.88	25.0	5.32	28.0	6.25	31.1	7.26
33	15.8			3.17	18.9	3.92	21.9	4.75	23.5	5.19	25.0	5.66	28.0	6.66	31.1	7.74
35	15.8			3.35	18.9	4.15	21.9	5.04	23.5	5.52	25.0	6.02	28.0	7.09	31.1	8.25
37	15.8			3.55	18.9	4.41	21.9	5.36	23.5	5.87	25.0	6.40	28.0	7.55	31.1	8.78
39	15.8			3.76	18.9	4.67	21.9	5.69	23.5	6.23	25.0	6.8	28.0	8.0	31.1	9.4

4TW33912-3A(7)

4 Capacity tables

4 - 1 Cooling Capacity Tables

RXYRQ12P - Correction factor for mixed connection: 0.7

TC: Total Capacity: kW ; PI: Power Input: kW (compressor + outdoor fan motor)

Combination (%)	Capacity index (kW)	Outdoor air temp. °CDB	Indoor air temperature:													
			14.0 °CWB		16.0 °CWB		18.0 °CWB		19.0 °CWB		20.0 °CWB		22.0 °CWB		24.0 °CWB	
			TC	PI	TC	PI	TC	PI	TC	PI	TC	PI	TC	PI	TC	PI
90 (30.15)	270	10	14.2	1.93	17.0	2.25	19.7	2.59	21.1	2.76	22.5	2.94	25.2	3.29	28.0	3.65
		12	14.2	1.96	17.0	2.29	19.7	2.63	21.1	2.81	22.5	2.98	25.2	3.34	28.0	3.71
		14	14.2	1.99	17.0	2.32	19.7	2.67	21.1	2.85	22.5	3.03	25.2	3.40	28.0	3.77
		16	14.2	2.01	17.0	2.36	19.7	2.71	21.1	2.90	22.5	3.08	25.2	3.45	28.0	3.83
		18	14.2	2.04	17.0	2.39	19.7	2.76	21.1	2.95	22.5	3.13	25.2	3.51	28.0	4.04
		20	14.2	2.08	17.0	2.43	19.7	2.81	21.1	3.00	22.5	3.24	25.2	3.77	28.0	4.33
		21	14.2	2.09	17.0	2.45	19.7	2.85	21.1	3.10	22.5	3.35	25.2	3.90	28.0	4.48
		23	14.2	2.12	17.0	2.55	19.7	3.04	21.1	3.30	22.5	3.58	25.2	4.17	28.0	4.80
		25	14.2	2.23	17.0	2.71	19.7	3.24	21.1	3.52	22.5	3.82	25.2	4.45	28.0	5.13
		27	14.2	2.37	17.0	2.88	19.7	3.45	21.1	3.75	22.5	4.07	25.2	4.75	28.0	5.48
		29	14.2	2.51	17.0	3.06	19.7	3.67	21.1	3.99	22.5	4.34	25.2	5.06	28.0	5.84
		31	14.2	2.66	17.0	3.25	19.7	3.90	21.1	4.25	22.5	4.61	25.2	5.39	28.0	6.23
		33	14.2	2.81	17.0	3.44	19.7	4.14	21.1	4.51	22.5	4.90	25.2	5.74	28.0	6.64
		35	14.2	2.98	17.0	3.65	19.7	4.39	21.1	4.79	22.5	5.21	25.2	6.10	28.0	7.07
		37	14.2	3.15	17.0	3.87	19.7	4.66	21.1	5.09	22.5	5.54	25.2	6.49	28.0	7.52
		39	14.2	3.33	17.0	4.09	19.7	4.95	21.1	5.40	22.5	5.88	25.2	6.9	28.0	8.0
		80	240 (26.80)	10	12.7	1.75	15.1	2.03	17.5	2.32	18.8	2.47	20.0	2.62	22.4	2.93
12	12.7			1.78	15.1	2.06	17.5	2.36	18.8	2.51	20.0	2.66	22.4	2.98	24.9	3.29
14	12.7			1.80	15.1	2.09	17.5	2.39	18.8	2.55	20.0	2.70	22.4	3.02	24.9	3.35
16	12.7			1.83	15.1	2.12	17.5	2.43	18.8	2.59	20.0	2.75	22.4	3.07	24.9	3.41
18	12.7			1.85	15.1	2.15	17.5	2.47	18.8	2.63	20.0	2.79	22.4	3.13	24.9	3.46
20	12.7			1.88	15.1	2.19	17.5	2.51	18.8	2.67	20.0	2.84	22.4	3.23	24.9	3.69
21	12.7			1.89	15.1	2.20	17.5	2.53	18.8	2.69	20.0	2.89	22.4	3.34	24.9	3.82
23	12.7			1.92	15.1	2.24	17.5	2.64	18.8	2.86	20.0	3.09	22.4	3.57	24.9	4.09
25	12.7			1.98	15.1	2.37	17.5	2.81	18.8	3.05	20.0	3.29	22.4	3.81	24.9	4.36
27	12.7			2.09	15.1	2.52	17.5	2.99	18.8	3.24	20.0	3.50	22.4	4.06	24.9	4.65
29	12.7			2.22	15.1	2.67	17.5	3.18	18.8	3.45	20.0	3.73	22.4	4.32	24.9	4.96
31	12.7			2.35	15.1	2.83	17.5	3.37	18.8	3.66	20.0	3.96	22.4	4.60	24.9	5.28
33	12.7			2.48	15.1	3.00	17.5	3.58	18.8	3.89	20.0	4.21	22.4	4.89	24.9	5.62
35	12.7			2.62	15.1	3.18	17.5	3.79	18.8	4.12	20.0	4.47	22.4	5.19	24.9	5.98
37	12.7			2.77	15.1	3.36	17.5	4.02	18.8	4.37	20.0	4.74	22.4	5.52	24.9	6.36
39	12.7			2.92	15.1	3.56	17.5	4.26	18.8	4.63	20.0	5.03	22.4	5.86	24.9	6.8

4TW33912-3A(8)

NOTES - ANMERKUNGEN - Σημειώσεις - NOTAS - REMARQUES - NOTE - OPMERKINGEN - Примечания - NOTLAR

- The above table shows the average value of conditions which may occur.
Die obige Tabelle zeigt den Durchschnittswert der Bedingungen, die auftreten können.
Στον παραπάνω πίνακα αναγράφεται η μέση τιμή για συνθήκες που μπορεί να προκύψουν.
La tabla de arriba muestra el valor medio de condiciones que pueden ocurrir.
Le tableau ci-dessus donne la valeur moyenne pour des conditions qui peuvent survenir.
La tabella in alto mostra il valore delle condizioni medie che si possono riscontrare.
De tabel hierboven geeft de gemiddelde waarde aan van situaties die kunnen voorvallen.
Таблица расположенная выше показывает среднее значение условий, которые могут наступить.
Yukarıdaki tablo meydana gelebilecek koşulların ortalama değerini göstermektedir.
- Correction factor for mixed connection: 0.7. For more information refer to the selection procedure.
Korrekturfaktoren für gemischten Anschluss: 0,7. Weitere Informationen finden Sie im Auswahlverfahren.
Συντελεστής διόρθωσης για συνδυαζόμενη σύνδεση: 0,7. Για περισσότερες πληροφορίες ανατρέξτε στη διαδικασία επιλογής.
Factor de corrección para conexión combinada: 0,7. Si desea más información, consulte el procedimiento de selección.
Facteur de correction pour connexion d'unités mixtes : 0,7. Pour plus d'informations, se reporter à la procédure de sélection.
Fattore di correzione per collegamento varie unità: 0,7. Per maggiori informazioni fare riferimento alla procedura di selezione.
Correctiefactor voor gemengde aansluiting: 0,7. Zie selectieprocedure voor meer informatie.
Поправочный коэффициент для комбинированного соединения: 0,7. Подробная информация приводится в разделе порядка выбора.
Karışık bağlantı için düzeltme faktörü: 0,7. Daha fazla bilgi için, seçim prosedürüne bakın.

4 Capacity tables

4 - 1 Cooling Capacity Tables

RXYRQ12P - Correction factor for mixed connection: 0.6																		
TC: Total Capacity: kW ; PI: Power Input: kW (compressor + outdoor fan motor)																		
Combination (%)	Capacity index (kW)	Outdoor air temp. °CDB	Indoor air temperature:															
			14.0 °CWB		16.0 °CWB		18.0 °CWB		19.0 °CWB		20.0 °CWB		22.0 °CWB		24.0 °CWB			
			20.0 °CDB		23.0 °CDB		16.0 °CDB		27.0 °CDB		28.0 °CDB		30.0 °CDB		32.0 °CDB			
			TC	PI	TC	PI	TC	PI	TC	PI	TC	PI	TC	PI	TC	PI		
130	390 (43.55)	10	17.6	2.26	21.0	2.64	24.4	3.04	26.1	3.23	27.8	3.43	31.2	3.81	34.6	4.17		
		12	17.6	2.29	21.0	2.68	24.4	3.08	26.1	3.28	27.8	3.48	31.2	3.86	34.6	4.36		
		14	17.6	2.32	21.0	2.72	24.4	3.13	26.1	3.33	27.8	3.53	31.2	4.07	34.6	4.71		
		16	17.6	2.36	21.0	2.77	24.4	3.18	26.1	3.43	27.8	3.73	31.2	4.38	34.6	5.08		
		18	17.6	2.39	21.0	2.81	24.4	3.37	26.1	3.68	27.8	4.01	31.2	4.71	34.6	5.47		
		20	17.6	2.43	21.0	2.98	24.4	3.61	26.1	3.95	27.8	4.30	31.2	5.06	34.6	5.88		
		21	17.6	2.49	21.0	3.08	24.4	3.73	26.1	4.09	27.8	4.45	31.2	5.24	34.6	6.09		
		23	17.6	2.66	21.0	3.29	24.4	3.99	26.1	4.37	27.8	4.77	31.2	5.61	34.6	6.52		
		25	17.6	2.83	21.0	3.51	24.4	4.26	26.1	4.67	27.8	5.09	31.2	6.00	34.6	6.99		
		27	17.6	3.01	21.0	3.74	24.4	4.55	26.1	4.98	27.8	5.44	31.2	6.41	34.6	7.47		
		29	17.6	3.20	21.0	3.98	24.4	4.85	26.1	5.31	27.8	5.80	31.2	6.85	34.6	7.98		
		31	17.6	3.39	21.0	4.23	24.4	5.16	26.1	5.66	27.8	6.19	31.2	7.31	34.6	8.53		
		33	17.6	3.60	21.0	4.49	24.4	5.49	26.1	6.03	27.8	6.59	31.2	7.79	34.6	9.10		
		35	17.6	3.82	21.0	4.77	24.4	5.84	26.1	6.41	27.8	7.02	31.2	8.31	34.6	9.68		
		37	17.6	4.05	21.0	5.07	24.4	6.21	26.1	6.82	27.8	7.47	31.2	8.8	34.6	10.0		
		39	17.6	4.29	21.0	5.4	24.4	6.6	26.1	7.3	27.8	7.9	31.2	9.4	34.6	10.4		
		120	360 (40.20)	10	16.3	2.11	19.4	2.46	22.6	2.82	24.1	3.00	25.7	3.18	28.8	3.54	32.0	3.89
				12	16.3	2.14	19.4	2.50	22.6	2.86	24.1	3.05	25.7	3.23	28.8	3.59	32.0	3.94
14	16.3			2.17	19.4	2.53	22.6	2.91	24.1	3.09	25.7	3.28	28.8	3.64	32.0	4.20		
16	16.3			2.20	19.4	2.57	22.6	2.95	24.1	3.14	25.7	3.35	28.8	3.92	32.0	4.53		
18	16.3			2.23	19.4	2.61	22.6	3.04	24.1	3.31	25.7	3.60	28.8	4.21	32.0	4.87		
20	16.3			2.26	19.4	2.70	22.6	3.25	24.1	3.55	25.7	3.86	28.8	4.52	32.0	5.23		
21	16.3			2.28	19.4	2.79	22.6	3.37	24.1	3.67	25.7	3.99	28.8	4.68	32.0	5.41		
23	16.3			2.43	19.4	2.98	22.6	3.60	24.1	3.93	25.7	4.27	28.8	5.01	32.0	5.80		
25	16.3			2.58	19.4	3.18	22.6	3.84	24.1	4.19	25.7	4.56	28.8	5.35	32.0	6.21		
27	16.3			2.74	19.4	3.38	22.6	4.09	24.1	4.47	25.7	4.87	28.8	5.72	32.0	6.64		
29	16.3			2.91	19.4	3.59	22.6	4.35	24.1	4.76	25.7	5.19	28.8	6.10	32.0	7.09		
31	16.3			3.09	19.4	3.82	22.6	4.63	24.1	5.07	25.7	5.53	28.8	6.50	32.0	7.56		
33	16.3			3.27	19.4	4.06	22.6	4.93	24.1	5.39	25.7	5.89	28.8	6.93	32.0	8.07		
35	16.3			3.47	19.4	4.30	22.6	5.24	24.1	5.74	25.7	6.26	28.8	7.38	32.0	8.60		
37	16.3			3.67	19.4	4.57	22.6	5.56	24.1	6.10	25.7	6.66	28.8	7.86	32.0	9.2		
39	16.3			3.89	19.4	4.84	22.6	5.9	24.1	6.5	25.7	7.1	28.8	8.4	32.0	9.8		
110	330 (36.85)			10	14.9	1.96	17.8	2.28	20.7	2.60	22.1	2.77	23.5	2.93	26.4	3.27	29.3	3.59
				12	14.9	1.98	17.8	2.31	20.7	2.64	22.1	2.81	23.5	2.98	26.4	3.31	29.3	3.64
		14	14.9	2.01	17.8	2.34	20.7	2.68	22.1	2.85	23.5	3.02	26.4	3.36	29.3	3.72		
		16	14.9	2.04	17.8	2.38	20.7	2.72	22.1	2.90	23.5	3.07	26.4	3.48	29.3	4.01		
		18	14.9	2.07	17.8	2.41	20.7	2.77	22.1	2.97	23.5	3.21	26.4	3.74	29.3	4.31		
		20	14.9	2.10	17.8	2.45	20.7	2.92	22.1	3.17	23.5	3.44	26.4	4.01	29.3	4.62		
		21	14.9	2.12	17.8	2.52	20.7	3.02	22.1	3.28	23.5	3.56	26.4	4.15	29.3	4.78		
		23	14.9	2.21	17.8	2.69	20.7	3.22	22.1	3.51	23.5	3.80	26.4	4.44	29.3	5.12		
		25	14.9	2.34	17.8	2.86	20.7	3.43	22.1	3.74	23.5	4.06	26.4	4.74	29.3	5.48		
		27	14.9	2.49	17.8	3.04	20.7	3.66	22.1	3.98	23.5	4.33	26.4	5.06	29.3	5.85		
		29	14.9	2.64	17.8	3.23	20.7	3.89	22.1	4.24	23.5	4.61	26.4	5.40	29.3	6.24		
		31	14.9	2.80	17.8	3.43	20.7	4.14	22.1	4.51	23.5	4.91	26.4	5.75	29.3	6.66		
		33	14.9	2.96	17.8	3.64	20.7	4.39	22.1	4.80	23.5	5.22	26.4	6.12	29.3	7.10		
		35	14.9	3.13	17.8	3.86	20.7	4.67	22.1	5.10	23.5	5.55	26.4	6.52	29.3	7.56		
		37	14.9	3.32	17.8	4.09	20.7	4.95	22.1	5.42	23.5	5.90	26.4	6.93	29.3	8.05		
		39	14.9	3.51	17.8	4.34	20.7	5.3	22.1	5.8	23.5	6.3	26.4	7.4	29.3	8.6		
		100	300 (33.50)	10	13.6	1.81	16.2	2.10	18.8	2.39	20.1	2.54	21.4	2.69	24.0	2.99	26.6	3.29
				12	13.6	1.84	16.2	2.13	18.8	2.42	20.1	2.58	21.4	2.73	24.0	3.03	26.6	3.34
14	13.6			1.86	16.2	2.16	18.8	2.46	20.1	2.61	21.4	2.77	24.0	3.08	26.6	3.39		
16	13.6			1.89	16.2	2.19	18.8	2.50	20.1	2.65	21.4	2.81	24.0	3.13	26.6	3.52		
18	13.6			1.91	16.2	2.22	18.8	2.54	20.1	2.70	21.4	2.86	24.0	3.30	26.6	3.78		
20	13.6			1.94	16.2	2.25	18.8	2.60	20.1	2.82	21.4	3.05	24.0	3.53	26.6	4.05		
21	13.6			1.95	16.2	2.27	18.8	2.69	20.1	2.91	21.4	3.15	24.0	3.65	26.6	4.19		
23	13.6			2.00	16.2	2.41	18.8	2.87	20.1	3.11	21.4	3.36	24.0	3.90	26.6	4.49		
25	13.6			2.12	16.2	2.56	18.8	3.05	20.1	3.31	21.4	3.59	24.0	4.17	26.6	4.79		
27	13.6			2.25	16.2	2.72	18.8	3.25	20.1	3.53	21.4	3.82	24.0	4.44	26.6	5.12		
29	13.6			2.38	16.2	2.89	18.8	3.45	20.1	3.75	21.4	4.07	24.0	4.74	26.6	5.46		
31	13.6			2.52	16.2	3.07	18.8	3.67	20.1	3.99	21.4	4.33	24.0	5.04	26.6	5.81		
33	13.6			2.67	16.2	3.25	18.8	3.89	20.1	4.24	21.4	4.60	24.0	5.36	26.6	6.19		
35	13.6			2.82	16.2	3.44	18.8	4.13	20.1	4.50	21.4	4.89	24.0	5.70	26.6	6.59		
37	13.6			2.98	16.2	3.65	18.8	4.38	20.1	4.78	21.4	5.19	24.0	6.06	26.6	7.01		
39	13.6			3.15	16.2	3.86	18.8	4.64	20.1	5.07	21.4	5.5	24.0	6.4	26.6	7.5		

4TW33912-3A(9)

4 Capacity tables

4 - 1 Cooling Capacity Tables

RXYRQ12P - Correction factor for mixed connection: 0.6

TC: Total Capacity: kW ; PI: Power Input: kW (compressor + outdoor fan motor)

Combination (%)	Capacity index (kW)	Outdoor air temp. °CDB	Indoor air temperature:															
			14.0 °CWB		16.0 °CWB		18.0 °CWB		19.0 °CWB		20.0 °CWB		22.0 °CWB		24.0 °CWB			
			20.0 °CDB		23.0 °CDB		16.0 °CDB		27.0 °CDB		28.0 °CDB		30.0 °CDB		32.0 °CDB			
			TC	PI	TC	PI	TC	PI	TC	PI	TC	PI	TC	PI	TC	PI		
90	270 (30.15)	10	12.2	1.67	14.6	1.92	16.9	2.18	18.1	2.31	19.3	2.44	21.6	2.71	24.0	2.98		
		12	12.2	1.69	14.6	1.94	16.9	2.21	18.1	2.34	19.3	2.48	21.6	2.75	24.0	3.03		
		14	12.2	1.71	14.6	1.97	16.9	2.24	18.1	2.38	19.3	2.52	21.6	2.79	24.0	3.07		
		16	12.2	1.73	14.6	2.00	16.9	2.27	18.1	2.41	19.3	2.55	21.6	2.84	24.0	3.12		
		18	12.2	1.76	14.6	2.03	16.9	2.31	18.1	2.45	19.3	2.59	21.6	2.88	24.0	3.29		
		20	12.2	1.78	14.6	2.06	16.9	2.34	18.1	2.49	19.3	2.68	21.6	3.09	24.0	3.52		
		21	12.2	1.79	14.6	2.07	16.9	2.38	18.1	2.57	19.3	2.77	21.6	3.19	24.0	3.64		
		23	12.2	1.82	14.6	2.15	16.9	2.53	18.1	2.74	19.3	2.95	21.6	3.41	24.0	3.89		
		25	12.2	1.91	14.6	2.28	16.9	2.70	18.1	2.92	19.3	3.15	21.6	3.63	24.0	4.16		
		27	12.2	2.02	14.6	2.42	16.9	2.87	18.1	3.10	19.3	3.35	21.6	3.87	24.0	4.43		
		29	12.2	2.14	14.6	2.57	16.9	3.04	18.1	3.30	19.3	3.56	21.6	4.12	24.0	4.72		
		31	12.2	2.26	14.6	2.72	16.9	3.23	18.1	3.50	19.3	3.78	21.6	4.38	24.0	5.03		
		33	12.2	2.39	14.6	2.88	16.9	3.42	18.1	3.71	19.3	4.02	21.6	4.66	24.0	5.35		
		35	12.2	2.52	14.6	3.05	16.9	3.63	18.1	3.94	19.3	4.26	21.6	4.95	24.0	5.69		
		37	12.2	2.66	14.6	3.23	16.9	3.84	18.1	4.18	19.3	4.52	21.6	5.26	24.0	6.05		
		39	12.2	2.81	14.6	3.41	16.9	4.07	18.1	4.43	19.3	4.79	21.6	5.6	24.0	6.4		
		80	240 (26.80)	10	10.9	1.53	12.9	1.75	15.0	1.97	16.1	2.08	17.1	2.20	19.2	2.44	21.3	2.68
				12	10.9	1.55	12.9	1.77	15.0	2.00	16.1	2.11	17.1	2.23	19.2	2.47	21.3	2.72
				14	10.9	1.57	12.9	1.79	15.0	2.02	16.1	2.14	17.1	2.26	19.2	2.51	21.3	2.76
16	10.9			1.59	12.9	1.82	15.0	2.05	16.1	2.18	17.1	2.30	19.2	2.55	21.3	2.80		
18	10.9			1.61	12.9	1.84	15.0	2.08	16.1	2.21	17.1	2.33	19.2	2.59	21.3	2.84		
20	10.9			1.63	12.9	1.87	15.0	2.11	16.1	2.24	17.1	2.37	19.2	2.67	21.3	3.03		
21	10.9			1.64	12.9	1.88	15.0	2.13	16.1	2.26	17.1	2.41	19.2	2.76	21.3	3.13		
23	10.9			1.66	12.9	1.91	15.0	2.22	16.1	2.39	17.1	2.57	19.2	2.94	21.3	3.34		
25	10.9			1.70	12.9	2.02	15.0	2.36	16.1	2.55	17.1	2.74	19.2	3.14	21.3	3.57		
27	10.9			1.80	12.9	2.14	15.0	2.51	16.1	2.70	17.1	2.91	19.2	3.34	21.3	3.80		
29	10.9			1.91	12.9	2.27	15.0	2.66	16.1	2.87	17.1	3.09	19.2	3.55	21.3	4.04		
31	10.9			2.02	12.9	2.40	15.0	2.82	16.1	3.04	17.1	3.28	19.2	3.77	21.3	4.30		
33	10.9			2.13	12.9	2.54	15.0	2.99	16.1	3.23	17.1	3.48	19.2	4.00	21.3	4.57		
35	10.9			2.24	12.9	2.68	15.0	3.16	16.1	3.42	17.1	3.68	19.2	4.25	21.3	4.86		
37	10.9			2.37	12.9	2.83	15.0	3.35	16.1	3.62	17.1	3.90	19.2	4.51	21.3	5.16		
39	10.9			2.49	12.9	2.99	15.0	3.54	16.1	3.83	17.1	4.13	19.2	4.78	21.3	5.5		

4TW33912-3A(10)

NOTES - ANMERKUNGEN - Σημειώσεις - NOTAS - REMARQUES - NOTE - OPMERKINGEN - Примечания - NOTLAR

- The above table shows the average value of conditions which may occur.
Die obige Tabelle zeigt den Durchschnittswert der Bedingungen, die auftreten können.
Στον παραπάνω πίνακα αναγράφεται η μέση τιμή για συνθήκες που μπορεί να προκύψουν.
La tabla de arriba muestra el valor medio de condiciones que pueden ocurrir.
Le tableau ci-dessus donne la valeur moyenne pour des conditions qui peuvent survenir.
La tabella in alto mostra il valore delle condizioni medie che si possono riscontrare.
De tabel hierboven geeft de gemiddelde waarde aan van situaties die kunnen voorvallen.
Таблица расположенная выше показывает среднее значение условий, которые могут наступить.
Yukarıdaki tablo meydana gelebilecek koşulların ortalama değerini göstermektedir.
- Correction factor for mixed connection: 0.6. For more information refer to the selection procedure.
Korrekturfaktoren für gemischten Anschluss: 0,6. Weitere Informationen finden Sie im Auswahlverfahren.
Συντελεστής διόρθωσης για συνδυαζόμενη σύνδεση: 0,6. Για περισσότερες πληροφορίες ανατρέξτε στη διαδικασία επιλογής.
Factor de corrección para conexión combinada: 0,6. Si desea más información, consulte el procedimiento de selección.
Facteur de correction pour connexion d'unités mixtes : 0,6. Pour plus d'informations, se reporter à la procédure de sélection.
Fattore di correzione per collegamento varie unità: 0,6. Per maggiori informazioni fare riferimento alla procedura di selezione.
Correctiefactor voor gemengde aansluiting: 0,6. Zie selectieprocedure voor meer informatie.
Поправочный коэффициент для комбинированного соединения: 0,6. Подробная информация приводится в разделе порядка выбора.
Karışık bağlantı için düzeltme faktörü: 0.6. Daha fazla bilgi için, seçim prosedürüne bakın.

4 Capacity tables

4 - 1 Cooling Capacity Tables

RXYRQ14P - Correction factor for mixed connection: 1.0																
TC: Total Capacity: kW ; PI: Power Input: kW (compressor + outdoor fan motor)																
Combination (%)	Capacity index (kW)	Outdoor air temp. °CDB	Indoor air temperature:													
			14.0 °CWB		16.0 °CWB		18.0 °CWB		19.0 °CWB		20.0 °CWB		22.0 °CWB		24.0 °CWB	
			20.0 °CDB	23.0 °CDB	16.0 °CDB	19.0 °CDB	20.0 °CDB	22.0 °CDB	24.0 °CDB	26.0 °CDB	28.0 °CDB	30.0 °CDB	24.0 °CWB	32.0 °CDB		
130	455 (52.00)	10	35.1	5.25	41.9	6.43	48.6	7.64	50.4	7.80	51.0	7.64	52.3	7.32	53.5	6.99
		12	35.1	5.35	41.9	6.55	48.6	7.79	49.7	7.76	50.4	7.60	51.6	7.27	52.9	7.16
		14	35.1	5.45	41.9	6.67	48.4	7.89	49.1	7.72	49.7	7.56	51.0	7.50	52.2	7.57
		16	35.1	5.55	41.9	6.80	47.8	7.85	48.4	7.79	49.1	7.83	50.3	7.90	51.6	7.98
		18	35.1	5.66	41.9	6.94	47.1	8.15	47.8	8.19	48.4	8.23	49.7	8.31	50.9	8.39
		20	35.1	5.77	41.9	7.39	46.5	8.5	47.1	8.6	47.8	8.6	49.0	8.7	50.3	8.8
		21	35.1	5.94	41.9	7.65	46.2	8.7	46.8	8.8	47.4	8.8	48.7	8.9	50.0	9.0
		23	35.1	6.35	41.9	8.21	45.5	9.1	46.1	9.2	46.8	9.2	48.0	9.3	49.3	9.4
		25	35.1	6.80	41.9	8.8	44.9	9.5	45.5	9.6	46.1	9.6	47.4	9.7	48.7	9.8
		27	35.1	7.26	41.9	9.4	44.2	9.9	44.8	10.0	45.5	10.0	46.7	10.2	48.0	10.3
		29	35.1	7.75	41.9	10.0	43.6	10.3	44.2	10.4	44.8	10.5	46.1	10.6	47.4	10.7
		31	35.1	8.26	41.6	10.6	42.9	10.8	43.5	10.8	44.2	10.9	45.4	11.0	46.7	11.1
		33	35.1	8.8	41.0	11.0	42.3	11.2	42.9	11.2	43.5	11.3	44.8	11.4	46.1	11.5
		35	35.1	9.4	40.3	11.4	41.6	11.6	42.2	11.6	42.9	11.7	44.1	11.8	45.4	12.0
		37	35.1	10.0	39.7	11.8	41.0	12.0	41.6	12.0	42.2	12.1	43.5	12.3	44.8	12.4
		39	35.1	10.6	39.0	12.2	40.3	12.4	40.9	12.5	41.6	12.5	42.8	12.7	44.1	12.8
		120	420 (48.00)	10	32.4	4.80	38.6	5.86	44.9	6.97	48.0	7.53	50.2	7.84	51.4	7.55
12	32.4			4.88	38.6	5.97	44.9	7.10	48.0	7.67	49.6	7.81	50.7	7.51	51.9	7.20
14	32.4			4.97	38.6	6.08	44.9	7.23	48.0	7.82	48.9	7.77	50.1	7.46	51.2	7.51
16	32.4			5.07	38.6	6.20	44.9	7.38	47.7	7.88	48.3	7.78	49.4	7.85	50.6	7.92
18	32.4			5.17	38.6	6.32	44.9	7.63	47.0	8.14	47.6	8.18	48.8	8.25	49.9	8.32
20	32.4			5.27	38.6	6.57	44.9	8.20	46.4	8.5	47.0	8.6	48.1	8.7	49.3	8.7
21	32.4			5.32	38.6	6.81	44.9	8.50	46.1	8.7	46.6	8.8	47.8	8.9	49.0	8.9
23	32.4			5.68	38.6	7.29	44.8	9.1	45.4	9.1	46.0	9.2	47.2	9.3	48.3	9.3
25	32.4			6.07	38.6	7.81	44.2	9.5	44.8	9.5	45.3	9.6	46.5	9.7	47.7	9.8
27	32.4			6.48	38.6	8.35	43.5	9.9	44.1	9.9	44.7	10.0	45.9	10.1	47.0	10.2
29	32.4			6.91	38.6	8.9	42.9	10.3	43.4	10.3	44.0	10.4	45.2	10.5	46.4	10.6
31	32.4			7.37	38.6	9.5	42.2	10.7	42.8	10.7	43.4	10.8	44.6	10.9	45.7	11.0
33	32.4			7.85	38.6	10.1	41.6	11.1	42.1	11.1	42.7	11.2	43.9	11.3	45.1	11.4
35	32.4			8.36	38.6	10.8	40.9	11.5	41.5	11.6	42.1	11.6	43.2	11.7	44.4	11.9
37	32.4			8.9	38.6	11.5	40.3	11.9	40.8	12.0	41.4	12.0	42.6	12.2	43.8	12.3
39	32.4			9.5	38.4	12.2	39.6	12.3	40.2	12.4	40.8	12.4	41.9	12.6	43.1	12.7
110	385 (44.00)			10	29.7	4.36	35.4	5.30	41.1	6.30	44.0	6.81	46.9	7.32	50.5	7.78
		12	29.7	4.43	35.4	5.40	41.1	6.42	44.0	6.94	46.9	7.46	49.8	7.74	50.9	7.46
		14	29.7	4.51	35.4	5.50	41.1	6.54	44.0	7.07	46.9	7.61	49.2	7.69	50.3	7.46
		16	29.7	4.60	35.4	5.61	41.1	6.67	44.0	7.21	46.9	7.75	48.5	7.80	49.6	7.86
		18	29.7	4.69	35.4	5.72	41.1	6.80	44.0	7.41	46.8	8.13	47.9	8.19	49.0	8.26
		20	29.7	4.78	35.4	5.83	41.1	7.20	44.0	7.96	46.2	8.5	47.2	8.6	48.3	8.7
		21	29.7	4.82	35.4	6.01	41.1	7.46	44.0	8.25	45.8	8.7	46.9	8.8	48.0	8.9
		23	29.7	5.05	35.4	6.44	41.1	8.00	44.0	8.8	45.2	9.1	46.3	9.2	47.3	9.3
		25	29.7	5.39	35.4	6.88	41.1	8.6	44.0	9.5	44.5	9.5	45.6	9.6	46.7	9.7
		27	29.7	5.75	35.4	7.35	41.1	9.2	43.4	9.9	43.9	9.9	45.0	10.0	46.0	10.1
		29	29.7	6.13	35.4	7.85	41.1	9.8	42.7	10.3	43.2	10.3	44.3	10.4	45.4	10.5
		31	29.7	6.53	35.4	8.37	41.1	10.5	42.0	10.7	42.6	10.7	43.7	10.8	44.7	10.9
		33	29.7	6.95	35.4	8.9	40.9	11.0	41.4	11.1	41.9	11.1	43.0	11.2	44.1	11.3
		35	29.7	7.39	35.4	9.5	40.2	11.4	40.7	11.5	41.3	11.5	42.4	11.6	43.4	11.8
		37	29.7	7.86	35.4	10.1	39.6	11.8	40.1	11.9	40.6	11.9	41.7	12.1	42.8	12.2
		39	29.7	8.36	35.4	10.8	38.9	12.2	39.4	12.3	40.0	12.4	41.1	12.5	42.1	12.6
		100	350 (40.00)	10	27.0	3.93	32.2	4.76	37.4	5.64	40.0	6.10	42.6	6.56	47.8	7.49
12	27.0			4.00	32.2	4.85	37.4	5.75	40.0	6.21	42.6	6.68	47.8	7.64	49.9	7.72
14	27.0			4.07	32.2	4.94	37.4	5.86	40.0	6.33	42.6	6.81	47.8	7.78	49.3	7.67
16	27.0			4.14	32.2	5.03	37.4	5.97	40.0	6.45	42.6	6.94	47.6	7.89	48.6	7.80
18	27.0			4.22	32.2	5.13	37.4	6.09	40.0	6.58	42.6	7.08	47.0	8.14	48.0	8.20
20	27.0			4.30	32.2	5.23	37.4	6.27	40.0	6.91	42.6	7.58	46.3	8.5	47.3	8.6
21	27.0			4.34	32.2	5.28	37.4	6.50	40.0	7.16	42.6	7.86	46.0	8.7	47.0	8.8
23	27.0			4.46	32.2	5.64	37.4	6.96	40.0	7.67	42.6	8.43	45.4	9.1	46.3	9.2
25	27.0			4.75	32.2	6.02	37.4	7.44	40.0	8.21	42.6	9.0	44.7	9.5	45.7	9.6
27	27.0			5.07	32.2	6.43	37.4	7.96	40.0	8.8	42.6	9.7	44.1	9.9	45.0	10.0
29	27.0			5.40	32.2	6.86	37.4	8.50	40.0	9.4	42.4	10.2	43.4	10.3	44.4	10.4
31	27.0			5.74	32.2	7.31	37.4	9.1	40.0	10.0	41.8	10.6	42.8	10.7	43.7	10.8
33	27.0			6.11	32.2	7.78	37.4	9.7	40.0	10.7	41.1	11.0	42.1	11.1	43.1	11.2
35	27.0			6.49	32.2	8.28	37.4	10.3	40.0	11.4	40.5	11.5	41.5	11.6	42.4	11.7
37	27.0			6.89	32.2	8.8	37.4	11.0	39.3	11.8	39.8	11.9	40.8	12.0	41.8	12.1
39	27.0			7.32	32.2	9.4	37.4	11.7	38.7	12.2	39.2	12.3	40.2	12.4	41.1	12.5

4TW33912-3A(1)

4 Capacity tables

4 - 1 Cooling Capacity Tables

RXYRQ14P - Correction factor for mixed connection: 1.0

TC: Total Capacity: kW ; PI: Power Input: kW (compressor + outdoor fan motor)

Combination (%)	Capacity index (kW)	Outdoor air temp. °CDB	Indoor air temperature:													
			14.0 °CWB		16.0 °CWB		18.0 °CWB		19.0 °CWB		20.0 °CWB		22.0 °CWB		24.0 °CWB	
			20.0 °CDB		23.0 °CDB		16.0 °CDB		27.0 °CDB		28.0 °CDB		30.0 °CDB		32.0 °CDB	
			TC	PI	TC	PI	TC	PI	TC	PI	TC	PI	TC	PI	TC	PI
90	315 (36.00)	10	24.3	3.52	29.0	4.24	33.7	5.01	36.0	5.40	38.3	5.81	43.0	6.63	47.7	7.48
		12	24.3	3.58	29.0	4.32	33.7	5.10	36.0	5.50	38.3	5.92	43.0	6.76	47.7	7.62
		14	24.3	3.64	29.0	4.39	33.7	5.19	36.0	5.61	38.3	6.03	43.0	6.89	47.7	7.76
		16	24.3	3.70	29.0	4.48	33.7	5.29	36.0	5.72	38.3	6.15	43.0	7.02	47.6	7.89
		18	24.3	3.77	29.0	4.56	33.7	5.40	36.0	5.83	38.3	6.27	43.0	7.16	47.0	8.14
		20	24.3	3.84	29.0	4.65	33.7	5.50	36.0	5.95	38.3	6.50	43.0	7.30	46.3	8.5
		21	24.3	3.87	29.0	4.69	33.7	5.60	36.0	6.15	38.3	6.73	43.0	7.47	46.0	8.7
		23	24.3	3.95	29.0	4.89	33.7	5.99	36.0	6.59	38.3	7.21	43.0	8.6	45.3	9.1
		25	24.3	4.16	29.0	5.22	33.7	6.41	36.0	7.05	38.3	7.72	43.0	9.2	44.7	9.5
		27	24.3	4.43	29.0	5.57	33.7	6.84	36.0	7.53	38.3	8.25	43.0	9.8	44.0	9.9
		29	24.3	4.71	29.0	5.93	33.7	7.30	36.0	8.04	38.3	8.8	42.5	10.3	43.4	10.3
		31	24.3	5.01	29.0	6.31	33.7	7.78	36.0	8.6	38.3	9.4	41.9	10.7	42.7	10.7
		33	24.3	5.32	29.0	6.72	33.7	8.29	36.0	9.1	38.3	10.0	41.2	11.1	42.1	11.1
		35	24.3	5.65	29.0	7.15	33.7	8.8	36.0	9.7	38.3	10.7	40.6	11.5	41.4	11.5
		37	24.3	5.99	29.0	7.60	33.7	9.4	36.0	10.4	38.3	11.4	39.9	11.9	40.8	12.0
		39	24.3	6.36	29.0	8.07	33.7	10.0	36.0	11.0	38.3	12.1	39.3	12.3	40.1	12.4
		80	280 (32.00)	10	21.6	3.12	25.8	3.74	29.9	4.39	32.0	4.73	34.1	5.08	38.2	5.79
12	21.6			3.17	25.8	3.80	29.9	4.47	32.0	4.82	34.1	5.17	38.2	5.90	42.4	6.65
14	21.6			3.22	25.8	3.87	29.9	4.55	32.0	4.91	34.1	5.27	38.2	6.01	42.4	6.77
16	21.6			3.28	25.8	3.94	29.9	4.64	32.0	5.00	34.1	5.37	38.2	6.13	42.4	6.91
18	21.6			3.34	25.8	4.01	29.9	4.73	32.0	5.10	34.1	5.47	38.2	6.25	42.4	7.04
20	21.6			3.39	25.8	4.09	29.9	4.82	32.0	5.20	34.1	5.58	38.2	6.48	42.4	7.53
21	21.6			3.42	25.8	4.12	29.9	4.86	32.0	5.25	34.1	5.70	38.2	6.71	42.4	7.80
23	21.6			3.49	25.8	4.20	29.9	5.10	32.0	5.59	34.1	6.10	38.2	7.19	42.4	8.37
25	21.6			3.60	25.8	4.48	29.9	5.45	32.0	5.97	34.1	6.52	38.2	7.69	42.4	9.0
27	21.6			3.83	25.8	4.77	29.9	5.81	32.0	6.37	34.1	6.96	38.2	8.22	42.4	9.6
29	21.6			4.07	25.8	5.07	29.9	6.19	32.0	6.80	34.1	7.43	38.2	8.8	42.4	10.2
31	21.6			4.32	25.8	5.40	29.9	6.60	32.0	7.24	34.1	7.92	38.2	9.4	41.8	10.6
33	21.6			4.59	25.8	5.74	29.9	7.02	32.0	7.71	34.1	8.44	38.2	10.0	41.1	11.0
35	21.6			4.86	25.8	6.10	29.9	7.47	32.0	8.21	34.1	9.0	38.2	10.7	40.4	11.4
37	21.6			5.16	25.8	6.47	29.9	7.94	32.0	8.74	34.1	9.6	38.2	11.4	39.8	11.9
39	21.6			5.46	25.8	6.87	29.9	8.44	32.0	9.29	34.1	10.2	38.2	12.1	39.1	12.3

4TW33912-3A(2)

NOTES - ANMERKUNGEN - Σημειώσεις - NOTAS - REMARQUES - NOTE - OPMERKINGEN - Примечания - NOTLAR

- The above table shows the average value of conditions which may occur.
Die obige Tabelle zeigt den Durchschnittswert der Bedingungen, die auftreten können.
Στον παραπάνω πίνακα αναγράφεται η μέση τιμή για συνθήκες που μπορεί να προκύψουν.
La tabla de arriba muestra el valor medio de condiciones que pueden ocurrir.
Le tableau ci-dessus donne la valeur moyenne pour des conditions qui peuvent survenir.
La tabella in alto mostra il valore delle condizioni medie che si possono riscontrare.
De tabel hierboven geeft de gemiddelde waarde aan van situaties die kunnen voorvallen.
Таблица расположенная выше показывает среднее значение условий, которые могут наступить.
Yukarıdaki tablo meydana gelebilecek koşulların ortalama değerini göstermektedir.
- Correction factor for mixed connection: 1.0. For more information refer to the selection procedure.
Korrekturfaktoren für gemischten Anschluss: 1,0. Weitere Informationen finden Sie im Auswahlverfahren.
Συντελεστής διόρθωσης για συνδυαζόμενη σύνδεση: 1,0. Για περισσότερες πληροφορίες ανατρέξτε στη διαδικασία επιλογής.
Factor de corrección para conexión combinada: 1,0. Si desea más información, consulte el procedimiento de selección.
Facteur de correction pour connexion d'unités mixtes : 1,0. Pour plus d'informations, se reporter à la procédure de sélection.
Fattore di correzione per collegamento varie unità: 1,0. Per maggiori informazioni fare riferimento alla procedura di selezione.
Correctiefactor voor gemengde aansluiting: 1,0. Zie selectieprocedure voor meer informatie.
Поправочный коэффициент для комбинированного соединения: 1,0. Подробная информация приводится в разделе порядка выбора.
Karışık bağlantı için düzeltme faktörü: 1.0. Daha fazla bilgi için, seçim prosedürüne bakın.

4 Capacity tables

4 - 1 Cooling Capacity Tables

RXYRQ14P - Correction factor for mixed connection: 0.9																
TC: Total Capacity: kW ; PI: Power Input: kW (compressor + outdoor fan motor)																
Combination (%)	Capacity index (kW)	Outdoor air temp. °CDB	Indoor air temperature:													
			14.0 °CWB		16.0 °CWB		18.0 °CWB		19.0 °CWB		20.0 °CWB		22.0 °CWB		24.0 °CWB	
			20.0 °CDB		23.0 °CDB		16.0 °CDB		27.0 °CDB		28.0 °CDB		30.0 °CDB		32.0 °CDB	
			TC	PI	TC	PI	TC	PI	TC	PI	TC	PI	TC	PI	TC	PI
130	455 (52.00)	10	31.6	4.56	37.7	5.53	43.8	6.54	46.8	7.04	49.8	7.55	52.3	7.32	53.5	6.99
		12	31.6	4.64	37.7	5.63	43.8	6.66	46.8	7.17	49.8	7.60	51.6	7.27	52.9	7.16
		14	31.6	4.72	37.7	5.74	43.8	6.78	46.8	7.30	49.7	7.56	51.0	7.50	52.2	7.57
		16	31.6	4.81	37.7	5.84	43.8	6.91	46.8	7.54	49.1	7.83	50.3	7.90	51.6	7.98
		18	31.6	4.90	37.7	5.96	43.8	7.35	46.8	8.13	48.4	8.23	49.7	8.31	50.9	8.39
		20	31.6	4.99	37.7	6.34	43.8	7.9	46.8	8.6	47.8	8.6	49.0	8.7	50.3	8.8
		21	31.6	5.13	37.7	6.56	43.8	8.2	46.8	8.8	47.4	8.8	48.7	8.9	50.0	9.0
		23	31.6	5.49	37.7	7.03	43.8	8.8	46.1	9.2	46.8	9.2	48.0	9.3	49.3	9.4
		25	31.6	5.86	37.7	7.5	43.8	9.4	45.5	9.6	46.1	9.6	47.4	9.7	48.7	9.8
		27	31.6	6.26	37.7	8.0	43.8	9.9	44.8	10.0	45.5	10.0	46.7	10.2	48.0	10.3
		29	31.6	6.67	37.7	8.6	43.6	10.3	44.2	10.4	44.8	10.5	46.1	10.6	47.4	10.7
		31	31.6	7.11	37.7	9.2	42.9	10.8	43.5	10.8	44.2	10.9	45.4	11.0	46.7	11.1
		33	31.6	7.6	37.7	9.8	42.3	11.2	42.9	11.2	43.5	11.3	44.8	11.4	46.1	11.5
		35	31.6	8.1	37.7	10.4	41.6	11.6	42.2	11.6	42.9	11.7	44.1	11.8	45.4	12.0
		37	31.6	8.6	37.7	11.1	41.0	12.0	41.6	12.0	42.2	12.1	43.5	12.3	44.8	12.4
		39	31.6	9.1	37.7	11.8	40.3	12.4	40.9	12.5	41.6	12.5	42.8	12.7	44.1	12.8
120	420 (48.00)	10	29.2	4.18	34.8	5.06	40.4	5.98	43.2	6.44	46.0	6.91	51.4	7.55	52.6	7.25
		12	29.2	4.25	34.8	5.15	40.4	6.09	43.2	6.56	46.0	7.04	50.7	7.51	51.9	7.20
		14	29.2	4.33	34.8	5.25	40.4	6.20	43.2	6.68	46.0	7.17	50.1	7.46	51.2	7.51
		16	29.2	4.41	34.8	5.35	40.4	6.32	43.2	6.81	46.0	7.35	49.4	7.85	50.6	7.92
		18	29.2	4.49	34.8	5.45	40.4	6.53	43.2	7.21	46.0	7.92	48.8	8.25	49.9	8.32
		20	29.2	4.58	34.8	5.66	40.4	7.01	43.2	7.7	46.0	8.5	48.1	8.7	49.3	8.7
		21	29.2	4.62	34.8	5.86	40.4	7.26	43.2	8.0	46.0	8.8	47.8	8.9	49.0	8.9
		23	29.2	4.93	34.8	6.27	40.4	7.8	43.2	8.6	46.0	9.2	47.2	9.3	48.3	9.3
		25	29.2	5.26	34.8	6.71	40.4	8.3	43.2	9.2	45.3	9.6	46.5	9.7	47.7	9.8
		27	29.2	5.61	34.8	7.16	40.4	8.9	43.2	9.9	44.7	10.0	45.9	10.1	47.0	10.2
		29	29.2	5.98	34.8	7.6	40.4	9.5	43.2	10.3	44.0	10.4	45.2	10.5	46.4	10.6
		31	29.2	6.37	34.8	8.2	40.4	10.2	42.8	10.7	43.4	10.8	44.6	10.9	45.7	11.0
		33	29.2	6.78	34.8	8.7	40.4	10.8	42.1	11.1	42.7	11.2	43.9	11.3	45.1	11.4
		35	29.2	7.21	34.8	9.3	40.4	11.5	41.5	11.6	42.1	11.6	43.2	11.7	44.4	11.9
		37	29.2	7.7	34.8	9.9	40.3	11.9	40.8	12.0	41.4	12.0	42.6	12.2	43.8	12.3
		39	29.2	8.1	34.8	10.5	39.6	12.3	40.2	12.4	40.8	12.4	41.9	12.6	43.1	12.7
110	385 (44.00)	10	26.7	3.82	31.9	4.60	37.0	5.43	39.6	5.85	42.2	6.27	47.3	7.13	51.6	7.51
		12	26.7	3.88	31.9	4.69	37.0	5.53	39.6	5.96	42.2	6.39	47.3	7.26	50.9	7.46
		14	26.7	3.95	31.9	4.77	37.0	5.63	39.6	6.07	42.2	6.51	47.3	7.39	50.3	7.46
		16	26.7	4.02	31.9	4.86	37.0	5.73	39.6	6.18	42.2	6.63	47.3	7.67	49.6	7.86
		18	26.7	4.09	31.9	4.95	37.0	5.84	39.6	6.34	42.2	6.96	47.3	8.19	49.0	8.26
		20	26.7	4.17	31.9	5.04	37.0	6.18	39.6	6.81	42.2	7.5	47.2	8.6	48.3	8.7
		21	26.7	4.21	31.9	5.20	37.0	6.40	39.6	7.06	42.2	7.7	46.9	8.8	48.0	8.9
		23	26.7	4.40	31.9	5.56	37.0	6.86	39.6	7.6	42.2	8.3	46.3	9.2	47.3	9.3
		25	26.7	4.69	31.9	5.94	37.0	7.3	39.6	8.1	42.2	8.9	45.6	9.6	46.7	9.7
		27	26.7	5.00	31.9	6.34	37.0	7.8	39.6	8.7	42.2	9.5	45.0	10.0	46.0	10.1
		29	26.7	5.32	31.9	6.76	37.0	8.4	39.6	9.2	42.2	10.2	44.3	10.4	45.4	10.5
		31	26.7	5.67	31.9	7.20	37.0	8.9	39.6	9.9	42.2	10.7	43.7	10.8	44.7	10.9
		33	26.7	6.02	31.9	7.7	37.0	9.5	39.6	10.5	41.9	11.1	43.0	11.2	44.1	11.3
		35	26.7	6.40	31.9	8.2	37.0	10.2	39.6	11.2	41.3	11.5	42.4	11.6	43.4	11.8
		37	26.7	6.80	31.9	8.7	37.0	10.8	39.6	11.9	40.6	11.9	41.7	12.1	42.8	12.2
		39	26.7	7.22	31.9	9.2	37.0	11.5	39.4	12.3	40.0	12.4	41.1	12.5	42.1	12.6
100	350 (40.00)	10	24.3	3.46	29.0	4.15	33.7	4.89	36.0	5.26	38.3	5.64	43.0	6.42	47.7	7.20
		12	24.3	3.52	29.0	4.23	33.7	4.97	36.0	5.36	38.3	5.74	43.0	6.53	47.7	7.32
		14	24.3	3.58	29.0	4.30	33.7	5.06	36.0	5.45	38.3	5.85	43.0	6.65	47.7	7.46
		16	24.3	3.64	29.0	4.38	33.7	5.16	36.0	5.56	38.3	5.96	43.0	6.78	47.7	7.77
		18	24.3	3.70	29.0	4.46	33.7	5.26	36.0	5.66	38.3	6.07	43.0	7.16	47.7	8.20
		20	24.3	3.77	29.0	4.54	33.7	5.41	36.0	5.94	38.3	6.50	43.0	7.7	47.3	8.6
		21	24.3	3.80	29.0	4.59	33.7	5.60	36.0	6.15	38.3	6.73	43.0	8.0	47.0	8.8
		23	24.3	3.90	29.0	4.89	33.7	5.99	36.0	6.59	38.3	7.21	43.0	8.6	46.3	9.2
		25	24.3	4.16	29.0	5.22	33.7	6.41	36.0	7.05	38.3	7.7	43.0	9.2	45.7	9.6
		27	24.3	4.43	29.0	5.57	33.7	6.84	36.0	7.5	38.3	8.3	43.0	9.8	45.0	10.0
		29	24.3	4.71	29.0	5.93	33.7	7.30	36.0	8.0	38.3	8.8	43.0	10.3	44.4	10.4
		31	24.3	5.01	29.0	6.31	33.7	7.8	36.0	8.6	38.3	9.4	42.8	10.7	43.7	10.8
		33	24.3	5.32	29.0	6.72	33.7	8.3	36.0	9.1	38.3	10.0	42.1	11.1	43.1	11.2
		35	24.3	5.65	29.0	7.15	33.7	8.8	36.0	9.7	38.3	10.7	41.5	11.6	42.4	11.7
		37	24.3	5.99	29.0	7.6	33.7	9.4	36.0	10.4	38.3	11.4	40.8	12.0	41.8	12.1
		39	24.3	6.36	29.0	8.1	33.7	10.0	36.0	11.0	38.3	12.1	40.2	12.4	41.1	12.5

4TW33912-3A(3)

4 Capacity tables

4 - 1 Cooling Capacity Tables

RXYRQ14P - Correction factor for mixed connection: 0.9

TC: Total Capacity: kW ; PI: Power Input: kW (compressor + outdoor fan motor)

Combination (%)	Capacity index (kW)	Outdoor air temp. °CDB	Indoor air temperature:													
			14.0 °CWB		16.0 °CWB		18.0 °CWB		19.0 °CWB		20.0 °CWB		22.0 °CWB		24.0 °CWB	
			TC	PI	TC	PI	TC	PI	TC	PI	TC	PI	TC	PI	TC	PI
90	315 (36.00)	10	21.9	3.11	26.1	3.72	30.3	4.36	32.4	4.69	34.5	5.02	38.7	5.70	42.9	6.40
		12	21.9	3.16	26.1	3.78	30.3	4.43	32.4	4.77	34.5	5.11	38.7	5.81	42.9	6.52
		14	21.9	3.22	26.1	3.85	30.3	4.51	32.4	4.86	34.5	5.20	38.7	5.92	42.9	6.64
		16	21.9	3.27	26.1	3.92	30.3	4.60	32.4	4.95	34.5	5.30	38.7	6.03	42.9	6.76
		18	21.9	3.32	26.1	3.99	30.3	4.68	32.4	5.04	34.5	5.40	38.7	6.14	42.9	7.14
		20	21.9	3.38	26.1	4.06	30.3	4.77	32.4	5.14	34.5	5.60	38.7	6.59	42.9	7.7
		21	21.9	3.41	26.1	4.10	30.3	4.85	32.4	5.31	34.5	5.80	38.7	6.83	42.9	7.9
		23	21.9	3.47	26.1	4.26	30.3	5.19	32.4	5.68	34.5	6.21	38.7	7.3	42.9	8.5
		25	21.9	3.66	26.1	4.55	30.3	5.54	32.4	6.07	34.5	6.63	38.7	7.8	42.9	9.1
		27	21.9	3.89	26.1	4.84	30.3	5.91	32.4	6.48	34.5	7.09	38.7	8.4	42.9	9.8
		29	21.9	4.13	26.1	5.16	30.3	6.30	32.4	6.92	34.5	7.6	38.7	8.9	42.9	10.3
		31	21.9	4.39	26.1	5.49	30.3	6.71	32.4	7.4	34.5	8.1	38.7	9.5	42.7	10.7
		33	21.9	4.66	26.1	5.83	30.3	7.14	32.4	7.9	34.5	8.6	38.7	10.2	42.1	11.1
		35	21.9	4.94	26.1	6.20	30.3	7.6	32.4	8.4	34.5	9.2	38.7	10.9	41.4	11.5
		37	21.9	5.24	26.1	6.58	30.3	8.1	32.4	8.9	34.5	9.7	38.7	11.6	40.8	12.0
		39	21.9	5.55	26.1	6.99	30.3	8.6	32.4	9.5	34.5	10.4	38.7	12.3	40.1	12.4
		80	280 (32.00)	10	19.4	2.78	23.2	3.30	26.9	3.85	28.8	4.13	30.7	4.42	34.4	5.01
12	19.4			2.82	23.2	3.35	26.9	3.91	28.8	4.20	30.7	4.49	34.4	5.10	38.2	5.72
14	19.4			2.87	23.2	3.41	26.9	3.98	28.8	4.27	30.7	4.57	34.4	5.19	38.2	5.82
16	19.4			2.91	23.2	3.47	26.9	4.05	28.8	4.35	30.7	4.66	34.4	5.29	38.2	5.93
18	19.4			2.96	23.2	3.53	26.9	4.12	28.8	4.43	30.7	4.75	34.4	5.39	38.2	6.04
20	19.4			3.01	23.2	3.59	26.9	4.20	28.8	4.51	30.7	4.84	34.4	5.58	38.2	6.46
21	19.4			3.04	23.2	3.62	26.9	4.24	28.8	4.56	30.7	4.93	34.4	5.78	38.2	6.69
23	19.4			3.09	23.2	3.69	26.9	4.44	28.8	4.85	30.7	5.27	34.4	6.18	38.2	7.17
25	19.4			3.19	23.2	3.92	26.9	4.74	28.8	5.18	30.7	5.63	34.4	6.61	38.2	7.7
27	19.4			3.39	23.2	4.18	26.9	5.05	28.8	5.52	30.7	6.01	34.4	7.06	38.2	8.2
29	19.4			3.60	23.2	4.44	26.9	5.38	28.8	5.88	30.7	6.41	34.4	7.5	38.2	8.8
31	19.4			3.81	23.2	4.72	26.9	5.72	28.8	6.26	30.7	6.83	34.4	8.0	38.2	9.3
33	19.4			4.04	23.2	5.01	26.9	6.08	28.8	6.66	30.7	7.27	34.4	8.6	38.2	10.0
35	19.4			4.28	23.2	5.32	26.9	6.47	28.8	7.09	30.7	7.7	34.4	9.1	38.2	10.6
37	19.4			4.53	23.2	5.64	26.9	6.87	28.8	7.53	30.7	8.2	34.4	9.7	38.2	11.3
39	19.4			4.80	23.2	5.98	26.9	7.30	28.8	8.01	30.7	8.7	34.4	10.3	38.2	12.1

4TW33912-3A(4)

NOTES - ANMERKUNGEN - Σημειώσεις - NOTAS - REMARQUES - NOTE - OPMERKINGEN - Примечания - NOTLAR

- The above table shows the average value of conditions which may occur.
Die obige Tabelle zeigt den Durchschnittswert der Bedingungen, die auftreten können.
Στον παραπάνω πίνακα αναγράφεται η μέση τιμή για συνθήκες που μπορεί να προκύψουν.
La tabla de arriba muestra el valor medio de condiciones que pueden ocurrir.
Le tableau ci-dessus donne la valeur moyenne pour des conditions qui peuvent survenir.
La tabella in alto mostra il valore delle condizioni medie che si possono riscontrare.
De tabel hierboven geeft de gemiddelde waarde aan van situaties die kunnen voorvallen.
Таблица расположенная выше показывает среднее значение условий, которые могут наступить.
Yukarıdaki tablo meydana gelebilecek koşulların ortalama değerini göstermektedir.
- Correction factor for mixed connection: 0.9. For more information refer to the selection procedure.
Korrekturfaktoren für gemischten Anschluss: 0,9. Weitere Informationen finden Sie im Auswahlverfahren.
Συντελεστής διόρθωσης για συνδυαζόμενη σύνδεση: 0,9. Για περισσότερες πληροφορίες ανατρέξτε στη διαδικασία επιλογής.
Factor de corrección para conexión combinada: 0,9. Si desea más información, consulte el procedimiento de selección.
Facteur de correction pour connexion d'unités mixtes : 0,9. Pour plus d'informations, se reporter à la procédure de sélection.
Fattore di correzione per collegamento varie unità: 0,9. Per maggiori informazioni fare riferimento alla procedura di selezione.
Correctiefactor voor gemengde aansluiting: 0,9. Zie selectieprocedure voor meer informatie.
Поправочный коэффициент для комбинированного соединения: 0,9. Подробная информация приводится в разделе порядка выбора.
Karışık bağlantı için düzeltme faktörü: 0.9. Daha fazla bilgi için, seçim prosedürüne bakın.

4 Capacity tables

4 - 1 Cooling Capacity Tables

RXYRQ14P - Correction factor for mixed connection: 0.8																
TC: Total Capacity: kW ; PI: Power Input: kW (compressor + outdoor fan motor)																
Combination (%)	Capacity index (kW)	Outdoor air temp. °CDB	Indoor air temperature:													
			14.0 °CWB		16.0 °CWB		18.0 °CWB		19.0 °CWB		20.0 °CWB		22.0 °CWB		24.0 °CWB	
			20.0 °CDB		23.0 °CDB		16.0 °CDB		27.0 °CDB		28.0 °CDB		30.0 °CDB		32.0 °CDB	
			TC	PI	TC	PI	TC	PI	TC	PI	TC	PI	TC	PI	TC	PI
130	455 (52.00)	10	28.1	3.92	33.5	4.71	38.9	5.52	41.6	5.93	44.3	6.34	49.7	7.14	53.5	6.99
		12	28.1	3.98	33.5	4.79	38.9	5.62	41.6	6.03	44.3	6.44	49.7	7.26	52.9	7.16
		14	28.1	4.05	33.5	4.87	38.9	5.71	41.6	6.14	44.3	6.56	49.7	7.50	52.2	7.57
		16	28.1	4.12	33.5	4.96	38.9	5.82	41.6	6.33	44.3	6.95	49.7	7.90	51.6	7.98
		18	28.1	4.20	33.5	5.05	38.9	6.18	41.6	6.82	44.3	7.48	49.7	8.31	50.9	8.39
		20	28.1	4.27	33.5	5.37	38.9	6.6	41.6	7.3	44.3	8.0	49.0	8.7	50.3	8.8
		21	28.1	4.39	33.5	5.56	38.9	6.9	41.6	7.6	44.3	8.3	48.7	8.9	50.0	9.0
		23	28.1	4.69	33.5	5.95	38.9	7.4	41.6	8.1	44.3	8.9	48.0	9.3	49.3	9.4
		25	28.1	5.00	33.5	6.4	38.9	7.9	41.6	8.7	44.3	9.6	47.4	9.7	48.7	9.8
		27	28.1	5.34	33.5	6.8	38.9	8.4	41.6	9.3	44.3	10.0	46.7	10.2	48.0	10.3
		29	28.1	5.68	33.5	7.2	38.9	9.0	41.6	10.0	44.3	10.5	46.1	10.6	47.4	10.7
		31	28.1	6.05	33.5	7.7	38.9	9.6	41.6	10.6	44.2	10.9	45.4	11.0	46.7	11.1
		33	28.1	6.4	33.5	8.2	38.9	10.2	41.6	11.2	43.5	11.3	44.8	11.4	46.1	11.5
		35	28.1	6.8	33.5	8.8	38.9	10.9	41.6	11.6	42.9	11.7	44.1	11.8	45.4	12.0
		37	28.1	7.3	33.5	9.3	38.9	11.6	41.6	12.0	42.2	12.1	43.5	12.3	44.8	12.4
		39	28.1	7.7	33.5	9.9	38.9	12.4	40.9	12.5	41.6	12.5	42.8	12.7	44.1	12.8
120	420 (48.00)	10	25.9	3.61	30.9	4.33	35.9	5.07	38.4	5.45	40.9	5.82	45.9	6.57	50.9	7.25
		12	25.9	3.67	30.9	4.40	35.9	5.16	38.4	5.54	40.9	5.92	45.9	6.68	50.9	7.20
		14	25.9	3.73	30.9	4.48	35.9	5.25	38.4	5.64	40.9	6.03	45.9	6.80	50.9	7.51
		16	25.9	3.80	30.9	4.56	35.9	5.34	38.4	5.74	40.9	6.18	45.9	7.33	50.6	7.92
		18	25.9	3.86	30.9	4.64	35.9	5.52	38.4	6.07	40.9	6.65	45.9	7.89	49.9	8.32
		20	25.9	3.93	30.9	4.82	35.9	5.92	38.4	6.5	40.9	7.1	45.9	8.5	49.3	8.7
		21	25.9	3.97	30.9	4.98	35.9	6.13	38.4	6.7	40.9	7.4	45.9	8.8	49.0	8.9
		23	25.9	4.23	30.9	5.33	35.9	6.6	38.4	7.2	40.9	7.9	45.9	9.3	48.3	9.3
		25	25.9	4.51	30.9	5.69	35.9	7.0	38.4	7.7	40.9	8.5	45.9	9.7	47.7	9.8
		27	25.9	4.81	30.9	6.08	35.9	7.5	38.4	8.3	40.9	9.1	45.9	10.1	47.0	10.2
		29	25.9	5.12	30.9	6.5	35.9	8.0	38.4	8.8	40.9	9.7	45.2	10.5	46.4	10.6
		31	25.9	5.44	30.9	6.9	35.9	8.5	38.4	9.4	40.9	10.4	44.6	10.9	45.7	11.0
		33	25.9	5.78	30.9	7.3	35.9	9.1	38.4	10.1	40.9	11.1	43.9	11.3	45.1	11.4
		35	25.9	6.14	30.9	7.8	35.9	9.7	38.4	10.7	40.9	11.6	43.2	11.7	44.4	11.9
		37	25.9	6.5	30.9	8.3	35.9	10.3	38.4	11.4	40.9	12.0	42.6	12.2	43.8	12.3
		39	25.9	6.9	30.9	8.8	35.9	11.0	38.4	12.2	40.8	12.4	41.9	12.6	43.1	12.7
110	385 (44.00)	10	23.8	3.31	28.3	3.96	32.9	4.62	35.2	4.96	37.5	5.31	42.1	6.00	46.6	6.69
		12	23.8	3.37	28.3	4.02	32.9	4.70	35.2	5.05	37.5	5.40	42.1	6.10	46.6	6.80
		14	23.8	3.42	28.3	4.09	32.9	4.79	35.2	5.14	37.5	5.49	42.1	6.21	46.6	6.96
		16	23.8	3.48	28.3	4.16	32.9	4.87	35.2	5.23	37.5	5.59	42.1	6.44	46.6	7.51
		18	23.8	3.54	28.3	4.24	32.9	4.96	35.2	5.37	37.5	5.86	42.1	6.93	46.6	8.08
		20	23.8	3.60	28.3	4.31	32.9	5.24	35.2	5.76	37.5	6.3	42.1	7.4	46.6	8.7
		21	23.8	3.63	28.3	4.44	32.9	5.43	35.2	5.96	37.5	6.5	42.1	7.7	46.6	8.9
		23	23.8	3.79	28.3	4.75	32.9	5.81	35.2	6.4	37.5	7.0	42.1	8.3	46.6	9.3
		25	23.8	4.04	28.3	5.07	32.9	6.2	35.2	6.8	37.5	7.5	42.1	8.9	46.6	9.7
		27	23.8	4.30	28.3	5.40	32.9	6.6	35.2	7.3	37.5	8.0	42.1	9.5	46.0	10.1
		29	23.8	4.58	28.3	5.75	32.9	7.1	35.2	7.8	37.5	8.5	42.1	10.1	45.4	10.5
		31	23.8	4.87	28.3	6.13	32.9	7.5	35.2	8.3	37.5	9.1	42.1	10.8	44.7	10.9
		33	23.8	5.17	28.3	6.5	32.9	8.0	35.2	8.8	37.5	9.7	42.1	11.2	44.1	11.3
		35	23.8	5.49	28.3	6.9	32.9	8.5	35.2	9.4	37.5	10.3	42.1	11.6	43.4	11.8
		37	23.8	5.82	28.3	7.4	32.9	9.1	35.2	10.0	37.5	11.0	41.7	12.1	42.8	12.2
		39	23.8	6.17	28.3	7.8	32.9	9.7	35.2	10.7	37.5	11.7	41.1	12.5	42.1	12.6
100	350 (40.00)	10	21.6	3.02	25.8	3.59	29.9	4.18	32.0	4.49	34.1	4.80	38.2	5.42	42.4	6.05
		12	21.6	3.07	25.8	3.65	29.9	4.26	32.0	4.57	34.1	4.88	38.2	5.52	42.4	6.15
		14	21.6	3.12	25.8	3.71	29.9	4.33	32.0	4.65	34.1	4.97	38.2	5.61	42.4	6.26
		16	21.6	3.17	25.8	3.77	29.9	4.41	32.0	4.73	34.1	5.05	38.2	5.71	42.4	6.51
		18	21.6	3.22	25.8	3.84	29.9	4.48	32.0	4.81	34.1	5.15	38.2	6.03	42.4	7.01
		20	21.6	3.27	25.8	3.91	29.9	4.61	32.0	5.05	34.1	5.50	38.2	6.5	42.4	7.5
		21	21.6	3.30	25.8	3.94	29.9	4.77	32.0	5.22	34.1	5.70	38.2	6.7	42.4	7.8
		23	21.6	3.38	25.8	4.20	29.9	5.10	32.0	5.59	34.1	6.10	38.2	7.2	42.4	8.4
		25	21.6	3.60	25.8	4.48	29.9	5.45	32.0	5.97	34.1	6.5	38.2	7.7	42.4	9.0
		27	21.6	3.83	25.8	4.77	29.9	5.81	32.0	6.4	34.1	7.0	38.2	8.2	42.4	9.6
		29	21.6	4.07	25.8	5.07	29.9	6.19	32.0	6.8	34.1	7.4	38.2	8.8	42.4	10.2
		31	21.6	4.32	25.8	5.40	29.9	6.6	32.0	7.2	34.1	7.9	38.2	9.4	42.4	10.8
		33	21.6	4.59	25.8	5.74	29.9	7.0	32.0	7.7	34.1	8.4	38.2	10.0	42.4	11.2
		35	21.6	4.86	25.8	6.10	29.9	7.5	32.0	8.2	34.1	9.0	38.2	10.7	42.4	11.7
		37	21.6	5.16	25.8	6.5	29.9	7.9	32.0	8.7	34.1	9.6	38.2	11.4	41.8	12.1
		39	21.6	5.46	25.8	6.9	29.9	8.4	32.0	9.3	34.1	10.2	38.2	12.1	41.1	12.5

4TW33912-3A(5)

4 Capacity tables

4 - 1 Cooling Capacity Tables

RXYRQ14P - Correction factor for mixed connection: 0.8

TC: Total Capacity: kW ; PI: Power Input: kW (compressor + outdoor fan motor)

Combination (%)	Capacity index (kW)	Outdoor air temp. °CDB	Indoor air temperature:													
			14.0 °CWB		16.0 °CWB		18.0 °CWB		19.0 °CWB		20.0 °CWB		22.0 °CWB		24.0 °CWB	
			TC	PI	TC	PI	TC	PI	TC	PI	TC	PI	TC	PI	TC	PI
90	315 (36.00)	10	19.4	2.74	23.2	3.23	26.9	3.75	28.8	4.02	30.7	4.29	34.4	4.85	38.2	5.41
		12	19.4	2.78	23.2	3.29	26.9	3.82	28.8	4.09	30.7	4.37	34.4	4.93	38.2	5.50
		14	19.4	2.82	23.2	3.34	26.9	3.88	28.8	4.16	30.7	4.44	34.4	5.02	38.2	5.60
		16	19.4	2.86	23.2	3.39	26.9	3.95	28.8	4.23	30.7	4.52	34.4	5.11	38.2	5.70
		18	19.4	2.91	23.2	3.45	26.9	4.02	28.8	4.31	30.7	4.60	34.4	5.20	38.2	6.02
		20	19.4	2.96	23.2	3.51	26.9	4.09	28.8	4.39	30.7	4.77	34.4	5.58	38.2	6.5
		21	19.4	2.98	23.2	3.54	26.9	4.16	28.8	4.54	30.7	4.93	34.4	5.78	38.2	6.7
		23	19.4	3.03	23.2	3.62	26.9	4.44	28.8	4.85	30.7	5.27	34.4	6.2	38.2	7.2
		25	19.4	3.19	23.2	3.98	26.9	4.74	28.8	5.18	30.7	5.63	34.4	6.6	38.2	7.7
		27	19.4	3.39	23.2	4.18	26.9	5.05	28.8	5.52	30.7	6.01	34.4	7.1	38.2	8.2
		29	19.4	3.60	23.2	4.44	26.9	5.38	28.8	5.88	30.7	6.4	34.4	7.5	38.2	8.8
		31	19.4	3.81	23.2	4.72	26.9	5.72	28.8	6.3	30.7	6.8	34.4	8.0	38.2	9.3
		33	19.4	4.04	23.2	5.01	26.9	6.08	28.8	6.7	30.7	7.3	34.4	8.6	38.2	10.0
		35	19.4	4.28	23.2	5.32	26.9	6.5	28.8	7.1	30.7	7.7	34.4	9.1	38.2	10.6
		37	19.4	4.53	23.2	5.64	26.9	6.9	28.8	7.5	30.7	8.2	34.4	9.7	38.2	11.3
		39	19.4	4.80	23.2	5.98	26.9	7.3	28.8	8.0	30.7	8.7	34.4	10.3	38.2	12.1
		80	280 (32.00)	10	17.3	2.46	20.6	2.89	23.9	3.34	25.6	3.57	27.3	3.80	30.6	4.28
12	17.3			2.50	20.6	2.93	23.9	3.39	25.6	3.63	27.3	3.87	30.6	4.36	33.9	4.86
14	17.3			2.54	20.6	2.98	23.9	3.45	25.6	3.69	27.3	3.93	30.6	4.43	33.9	4.94
16	17.3			2.57	20.6	3.03	23.9	3.50	25.6	3.75	27.3	4.00	30.6	4.51	33.9	5.03
18	17.3			2.61	20.6	3.08	23.9	3.56	25.6	3.81	27.3	4.07	30.6	4.59	33.9	5.12
20	17.3			2.65	20.6	3.13	23.9	3.63	25.6	3.88	27.3	4.14	30.6	4.75	33.9	5.47
21	17.3			2.67	20.6	3.15	23.9	3.66	25.6	3.92	27.3	4.22	30.6	4.91	33.9	5.66
23	17.3			2.72	20.6	3.21	23.9	3.83	25.6	4.16	27.3	4.51	30.6	5.26	33.9	6.06
25	17.3			2.80	20.6	3.41	23.9	4.08	25.6	4.44	27.3	4.82	30.6	5.61	33.9	6.5
27	17.3			2.97	20.6	3.62	23.9	4.34	25.6	4.73	27.3	5.13	30.6	5.99	33.9	6.9
29	17.3			3.15	20.6	3.85	23.9	4.62	25.6	5.03	27.3	5.47	30.6	6.4	33.9	7.4
31	17.3			3.34	20.6	4.09	23.9	4.91	25.6	5.35	27.3	5.82	30.6	6.8	33.9	7.9
33	17.3			3.53	20.6	4.33	23.9	5.22	25.6	5.69	27.3	6.19	30.6	7.2	33.9	8.4
35	17.3			3.74	20.6	4.59	23.9	5.54	25.6	6.05	27.3	6.6	30.6	7.7	33.9	8.9
37	17.3			3.96	20.6	4.87	23.9	5.88	25.6	6.42	27.3	7.0	30.6	8.2	33.9	9.5
39	17.3			4.18	20.6	5.15	23.9	6.23	25.6	6.81	27.3	7.4	30.6	8.7	33.9	10.1

4TW33912-3A(6)

NOTES - ANMERKUNGEN - Σημειώσεις - NOTAS - REMARQUES - NOTE - OPMERKINGEN - Примечания - NOTLAR

- The above table shows the average value of conditions which may occur.
Die obige Tabelle zeigt den Durchschnittswert der Bedingungen, die auftreten können.
 Στον παραπάνω πίνακα αναγράφεται η μέση τιμή για συνθήκες που μπορεί να προκύψουν.
La tabla de arriba muestra el valor medio de condiciones que pueden ocurrir.
 Le tableau ci-dessus donne la valeur moyenne pour des conditions qui peuvent survenir.
La tabella in alto mostra il valore delle condizioni medie che si possono riscontrare.
 De tabel hierboven geeft de gemiddelde waarde aan van situaties die kunnen voorvallen.
Таблица расположенная выше показывает среднее значение условий, которые могут наступить.
 Yukarıdaki tablo meydana gelebilecek koşulların ortalama değerini göstermektedir.
- Correction factor for mixed connection: 0.8. For more information refer to the selection procedure.
Korrekturfaktoren für gemischten Anschluss: 0,8. Weitere Informationen finden Sie im Auswahlverfahren.
 Συντελεστής διόρθωσης για συνδυαζόμενη σύνδεση: 0,8. Για περισσότερες πληροφορίες ανατρέξτε στη διαδικασία επιλογής.
Factor de corrección para conexión combinada: 0,8. Si desea más información, consulte el procedimiento de selección.
 Facteur de correction pour connexion d'unités mixtes : 0,8. Pour plus d'informations, se reporter à la procédure de sélection.
Fattore di correzione per collegamento varie unità: 0,8. Per maggiori informazioni fare riferimento alla procedura di selezione.
 Correctiefactor voor gemengde aansluiting: 0,8. Zie selectieprocedure voor meer informatie.
Поправочный коэффициент для комбинированного соединения: 0,8. Подробная информация приводится в разделе порядка выбора.
 Karışık bağlantı için düzeltme faktörü: 0,8. Daha fazla bilgi için, seçim prosedürüne bakın.

4 Capacity tables

4 - 1 Cooling Capacity Tables

RXYRQ14P - Correction factor for mixed connection: 0.7																
TC: Total Capacity: kW ; PI: Power Input: kW (compressor + outdoor fan motor)																
Combination (%)	Capacity index (kW)	Outdoor air temp. °CDB	Indoor air temperature:													
			14.0 °CWB		16.0 °CWB		18.0 °CWB		19.0 °CWB		20.0 °CWB		22.0 °CWB		24.0 °CWB	
			20.0 °CDB		23.0 °CDB		16.0 °CDB		27.0 °CDB		28.0 °CDB		30.0 °CDB		32.0 °CDB	
			TC	PI	TC	PI	TC	PI	TC	PI	TC	PI	TC	PI	TC	PI
130	455 (52.00)	10	24.6	3.33	29.3	3.95	34.0	4.59	36.4	4.91	38.8	5.23	43.5	5.85	48.2	6.46
		12	24.6	3.38	29.3	4.02	34.0	4.67	36.4	4.99	38.8	5.31	43.5	5.95	48.2	6.76
		14	24.6	3.43	29.3	4.08	34.0	4.74	36.4	5.07	38.8	5.40	43.5	6.27	48.2	7.32
		16	24.6	3.49	29.3	4.15	34.0	4.82	36.4	5.23	38.8	5.72	43.5	6.76	48.2	7.90
		18	24.6	3.55	29.3	4.22	34.0	5.12	36.4	5.62	38.8	6.15	43.5	7.28	48.2	8.39
		20	24.6	3.61	29.3	4.49	34.0	5.5	36.4	6.0	38.8	6.6	43.5	7.8	48.2	8.8
		21	24.6	3.70	29.3	4.64	34.0	5.7	36.4	6.2	38.8	6.8	43.5	8.1	48.2	9.0
		23	24.6	3.95	29.3	4.96	34.0	6.1	36.4	6.7	38.8	7.3	43.5	8.7	48.2	9.4
		25	24.6	4.21	29.3	5.3	34.0	6.5	36.4	7.2	38.8	7.8	43.5	9.3	48.2	9.8
		27	24.6	4.49	29.3	5.6	34.0	6.9	36.4	7.7	38.8	8.4	43.5	10.0	48.0	10.3
		29	24.6	4.78	29.3	6.0	34.0	7.4	36.4	8.2	38.8	9.0	43.5	10.6	47.4	10.7
		31	24.6	5.08	29.3	6.4	34.0	7.9	36.4	8.7	38.8	9.6	43.5	11.0	46.7	11.1
		33	24.6	5.4	29.3	6.8	34.0	8.4	36.4	9.3	38.8	10.2	43.5	11.4	46.1	11.5
		35	24.6	5.7	29.3	7.3	34.0	9.0	36.4	9.9	38.8	10.9	43.5	11.8	45.4	12.0
		37	24.6	6.1	29.3	7.7	34.0	9.6	36.4	10.5	38.8	11.6	43.5	12.3	44.8	12.4
		39	24.6	6.5	29.3	8.2	34.0	10.2	36.4	11.2	38.8	12.3	42.8	12.7	44.1	12.8
120	420 (48.00)	10	22.7	3.09	27.0	3.65	31.4	4.24	33.6	4.53	35.8	4.83	40.2	5.41	44.5	5.99
		12	22.7	3.13	27.0	3.71	31.4	4.31	33.6	4.61	35.8	4.91	40.2	5.50	44.5	6.08
		14	22.7	3.18	27.0	3.77	31.4	4.38	33.6	4.68	35.8	4.99	40.2	5.59	44.5	6.49
		16	22.7	3.23	27.0	3.83	31.4	4.45	33.6	4.76	35.8	5.11	40.2	6.02	44.5	7.00
		18	22.7	3.28	27.0	3.90	31.4	4.59	33.6	5.03	35.8	5.49	40.2	6.47	44.5	7.54
		20	22.7	3.34	27.0	4.04	31.4	4.92	33.6	5.4	35.8	5.9	40.2	7.0	44.5	8.1
		21	22.7	3.37	27.0	4.18	31.4	5.09	33.6	5.6	35.8	6.1	40.2	7.2	44.5	8.4
		23	22.7	3.58	27.0	4.47	31.4	5.4	33.6	6.0	35.8	6.5	40.2	7.7	44.5	9.0
		25	22.7	3.82	27.0	4.77	31.4	5.8	33.6	6.4	35.8	7.0	40.2	8.3	44.5	9.6
		27	22.7	4.06	27.0	5.08	31.4	6.2	33.6	6.8	35.8	7.5	40.2	8.8	44.5	10.2
		29	22.7	4.32	27.0	5.4	31.4	6.6	33.6	7.3	35.8	8.0	40.2	9.4	44.5	10.6
		31	22.7	4.59	27.0	5.8	31.4	7.1	33.6	7.8	35.8	8.5	40.2	10.1	44.5	11.0
		33	22.7	4.87	27.0	6.1	31.4	7.5	33.6	8.3	35.8	9.1	40.2	10.8	44.5	11.4
		35	22.7	5.17	27.0	6.5	31.4	8.0	33.6	8.8	35.8	9.7	40.2	11.5	44.4	11.9
		37	22.7	5.5	27.0	6.9	31.4	8.5	33.6	9.4	35.8	10.3	40.2	12.2	43.8	12.3
		39	22.7	5.8	27.0	7.3	31.4	9.1	33.6	10.0	35.8	10.9	40.2	12.6	43.1	12.7
110	385 (44.00)	10	20.8	2.85	24.8	3.36	28.8	3.89	30.8	4.15	32.8	4.42	36.8	4.97	40.8	5.50
		12	20.8	2.89	24.8	3.41	28.8	3.95	30.8	4.22	32.8	4.50	36.8	5.05	40.8	5.59
		14	20.8	2.93	24.8	3.46	28.8	4.01	30.8	4.29	32.8	4.57	36.8	5.13	40.8	5.71
		16	20.8	2.98	24.8	3.52	28.8	4.08	30.8	4.36	32.8	4.65	36.8	5.31	40.8	6.16
		18	20.8	3.03	24.8	3.58	28.8	4.15	30.8	4.47	32.8	4.87	36.8	5.71	40.8	6.63
		20	20.8	3.07	24.8	3.64	28.8	4.38	30.8	4.79	32.8	5.2	36.8	6.1	40.8	7.1
		21	20.8	3.10	24.8	3.75	28.8	4.54	30.8	4.96	32.8	5.4	36.8	6.3	40.8	7.4
		23	20.8	3.23	24.8	4.00	28.8	4.85	30.8	5.3	32.8	5.8	36.8	6.8	40.8	7.9
		25	20.8	3.44	24.8	4.26	28.8	5.2	30.8	5.7	32.8	6.2	36.8	7.3	40.8	8.5
		27	20.8	3.66	24.8	4.54	28.8	5.5	30.8	6.0	32.8	6.6	36.8	7.8	40.8	9.1
		29	20.8	3.89	24.8	4.83	28.8	5.9	30.8	6.4	32.8	7.0	36.8	8.3	40.8	9.7
		31	20.8	4.13	24.8	5.14	28.8	6.3	30.8	6.9	32.8	7.5	36.8	8.9	40.8	10.3
		33	20.8	4.38	24.8	5.5	28.8	6.7	30.8	7.3	32.8	8.0	36.8	9.4	40.8	11.0
		35	20.8	4.64	24.8	5.8	28.8	7.1	30.8	7.8	32.8	8.5	36.8	10.1	40.8	11.8
		37	20.8	4.92	24.8	6.2	28.8	7.5	30.8	8.3	32.8	9.1	36.8	10.7	40.8	12.2
		39	20.8	5.21	24.8	6.5	28.8	8.0	30.8	8.8	32.8	9.6	36.8	11.4	40.8	12.6
100	350 (40.00)	10	18.9	2.61	22.5	3.07	26.2	3.54	28.0	3.78	29.8	4.02	33.5	4.51	37.1	5.01
		12	18.9	2.65	22.5	3.11	26.2	3.60	28.0	3.84	29.8	4.09	33.5	4.59	37.1	5.09
		14	18.9	2.69	22.5	3.16	26.2	3.65	28.0	3.90	29.8	4.16	33.5	4.66	37.1	5.17
		16	18.9	2.73	22.5	3.21	26.2	3.71	28.0	3.97	29.8	4.23	33.5	4.74	37.1	5.37
		18	18.9	2.77	22.5	3.27	26.2	3.78	28.0	4.04	29.8	4.30	33.5	5.00	37.1	5.78
		20	18.9	2.82	22.5	3.32	26.2	3.88	28.0	4.23	29.8	4.59	33.5	5.4	37.1	6.2
		21	18.9	2.84	22.5	3.35	26.2	4.01	28.0	4.37	29.8	4.75	33.5	5.6	37.1	6.4
		23	18.9	2.90	22.5	3.56	26.2	4.28	28.0	4.67	29.8	5.08	33.5	5.9	37.1	6.9
		25	18.9	3.09	22.5	3.79	26.2	4.57	28.0	4.99	29.8	5.4	33.5	6.4	37.1	7.4
		27	18.9	3.28	22.5	4.03	26.2	4.87	28.0	5.3	29.8	5.8	33.5	6.8	37.1	7.9
		29	18.9	3.48	22.5	4.29	26.2	5.18	28.0	5.7	29.8	6.2	33.5	7.2	37.1	8.4
		31	18.9	3.69	22.5	4.56	26.2	5.5	28.0	6.0	29.8	6.6	33.5	7.7	37.1	9.0
		33	18.9	3.91	22.5	4.84	26.2	5.9	28.0	6.4	29.8	7.0	33.5	8.2	37.1	9.6
		35	18.9	4.14	22.5	5.13	26.2	6.2	28.0	6.8	29.8	7.4	33.5	8.8	37.1	10.2
		37	18.9	4.39	22.5	5.4	26.2	6.6	28.0	7.2	29.8	7.9	33.5	9.3	37.1	10.8
		39	18.9	4.64	22.5	5.8	26.2	7.0	28.0	7.7	29.8	8.4	33.5	9.9	37.1	11.6

4TW33912-3A(7)

4 Capacity tables

4 - 1 Cooling Capacity Tables

RXYRQ14P - Correction factor for mixed connection: 0.7

TC: Total Capacity: kW ; PI: Power Input: kW (compressor + outdoor fan motor)

Combination (%)	Capacity index (kW)	Outdoor air temp. °CDB	Indoor air temperature:													
			14.0 °CWB		16.0 °CWB		18.0 °CWB		19.0 °CWB		20.0 °CWB		22.0 °CWB		24.0 °CWB	
			TC	PI	TC	PI	TC	PI	TC	PI	TC	PI	TC	PI	TC	PI
90	315 (36.00)	10	17.0	2.39	20.3	2.78	23.6	3.20	25.2	3.41	26.8	3.63	30.1	4.06	33.4	4.50
		12	17.0	2.42	20.3	2.83	23.6	3.25	25.2	3.46	26.8	3.68	30.1	4.13	33.4	4.58
		14	17.0	2.45	20.3	2.87	23.6	3.30	25.2	3.52	26.8	3.74	30.1	4.20	33.4	4.65
		16	17.0	2.49	20.3	2.91	23.6	3.35	25.2	3.58	26.8	3.81	30.1	4.27	33.4	4.73
		18	17.0	2.53	20.3	2.96	23.6	3.41	25.2	3.64	26.8	3.87	30.1	4.34	33.4	4.99
		20	17.0	2.56	20.3	3.01	23.6	3.46	25.2	3.70	26.8	4.00	30.1	4.65	33.4	5.4
		21	17.0	2.58	20.3	3.03	23.6	3.52	25.2	3.82	26.8	4.14	30.1	4.81	33.4	5.5
		23	17.0	2.62	20.3	3.15	23.6	3.76	25.2	4.08	26.8	4.42	30.1	5.1	33.4	5.9
		25	17.0	2.75	20.3	3.35	23.6	4.00	25.2	4.35	26.8	4.72	30.1	5.5	33.4	6.3
		27	17.0	2.92	20.3	3.56	23.6	4.26	25.2	4.64	26.8	5.03	30.1	5.9	33.4	6.8
		29	17.0	3.10	20.3	3.78	23.6	4.53	25.2	4.93	26.8	5.4	30.1	6.3	33.4	7.2
		31	17.0	3.28	20.3	4.01	23.6	4.81	25.2	5.2	26.8	5.7	30.1	6.7	33.4	7.7
		33	17.0	3.47	20.3	4.25	23.6	5.11	25.2	5.6	26.8	6.1	30.1	7.1	33.4	8.2
		35	17.0	3.67	20.3	4.51	23.6	5.4	25.2	5.9	26.8	6.4	30.1	7.5	33.4	8.7
		37	17.0	3.89	20.3	4.77	23.6	5.8	25.2	6.3	26.8	6.8	30.1	8.0	33.4	9.3
		39	17.0	4.11	20.3	5.06	23.6	6.1	25.2	6.7	26.8	7.3	30.1	8.5	33.4	9.9
		80	280 (32.00)	10	15.1	2.17	18.0	2.51	20.9	2.87	22.4	3.05	23.9	3.24	26.8	3.62
12	15.1			2.19	18.0	2.54	20.9	2.91	22.4	3.10	23.9	3.29	26.8	3.67	29.7	4.07
14	15.1			2.22	18.0	2.58	20.9	2.95	22.4	3.14	23.9	3.34	26.8	3.73	29.7	4.14
16	15.1			2.25	18.0	2.62	20.9	3.00	22.4	3.19	23.9	3.39	26.8	3.80	29.7	4.21
18	15.1			2.29	18.0	2.66	20.9	3.05	22.4	3.25	23.9	3.45	26.8	3.86	29.7	4.28
20	15.1			2.32	18.0	2.70	20.9	3.10	22.4	3.30	23.9	3.51	26.8	3.99	29.7	4.56
21	15.1			2.34	18.0	2.72	20.9	3.12	22.4	3.33	23.9	3.57	26.8	4.13	29.7	4.72
23	15.1			2.37	18.0	2.76	20.9	3.26	22.4	3.53	23.9	3.81	26.8	4.41	29.7	5.05
25	15.1			2.44	18.0	2.93	20.9	3.47	22.4	3.76	23.9	4.06	26.8	4.70	29.7	5.4
27	15.1			2.59	18.0	3.11	20.9	3.69	22.4	4.00	23.9	4.33	26.8	5.01	29.7	5.7
29	15.1			2.74	18.0	3.30	20.9	3.92	22.4	4.26	23.9	4.60	26.8	5.3	29.7	6.1
31	15.1			2.90	18.0	3.50	20.9	4.17	22.4	4.52	23.9	4.89	26.8	5.7	29.7	6.5
33	15.1			3.06	18.0	3.71	20.9	4.42	22.4	4.80	23.9	5.20	26.8	6.0	29.7	6.9
35	15.1			3.24	18.0	3.92	20.9	4.68	22.4	5.09	23.9	5.5	26.8	6.4	29.7	7.4
37	15.1			3.42	18.0	4.15	20.9	4.96	22.4	5.40	23.9	5.9	26.8	6.8	29.7	7.9
39	15.1			3.61	18.0	4.39	20.9	5.26	22.4	5.72	23.9	6.2	26.8	7.2	29.7	8.4

4TW33912-3A(8)

NOTES - ANMERKUNGEN - Σημειώσεις - NOTAS - REMARQUES - NOTE - OPMERKINGEN - Примечания - NOTLAR

- The above table shows the average value of conditions which may occur.
Die obige Tabelle zeigt den Durchschnittswert der Bedingungen, die auftreten können.
 Στον παραπάνω πίνακα αναγράφεται η μέση τιμή για συνθήκες που μπορεί να προκύψουν.
La tabla de arriba muestra el valor medio de condiciones que pueden ocurrir.
 Le tableau ci-dessus donne la valeur moyenne pour des conditions qui peuvent survenir.
La tabella in alto mostra il valore delle condizioni medie che si possono riscontrare.
 De tabel hierboven geeft de gemiddelde waarde aan van situaties die kunnen voorvallen.
 Таблица расположенная выше показывает среднее значение условий, которые могут наступить.
 Yukarıdaki tablo meydana gelebilecek koşulların ortalama değerini göstermektedir.
- Correction factor for mixed connection: 0.7. For more information refer to the selection procedure.
Korrekturfaktoren für gemischten Anschluss: 0,7. Weitere Informationen finden Sie im Auswahlverfahren.
 Συντελεστής διόρθωσης για συνδυαζόμενη σύνδεση: 0,7. Για περισσότερες πληροφορίες ανατρέξτε στη διαδικασία επιλογής.
Factor de corrección para conexión combinada: 0,7. Si desea más información, consulte el procedimiento de selección.
 Facteur de correction pour connexion d'unités mixtes : 0,7. Pour plus d'informations, se reporter à la procédure de sélection.
Fattore di correzione per collegamento varie unità: 0,7. Per maggiori informazioni fare riferimento alla procedura di selezione.
 Correctiefactor voor gemengde aansluiting: 0,7. Zie selectieprocedure voor meer informatie.
 Поправочный коэффициент для комбинированного соединения: 0,7. Подробная информация приводится в разделе порядка выбора.
 Karışık bağlantı için düzeltme faktörü: 0,7. Daha fazla bilgi için, seçim prosedürüne bakın.

4 Capacity tables

4 - 1 Cooling Capacity Tables

RXYRQ14P - Correction factor for mixed connection: 0.6																
TC: Total Capacity: kW ; PI: Power Input: kW (compressor + outdoor fan motor)																
Combination (%)	Capacity index (kW)	Outdoor air temp. °CDB	Indoor air temperature:													
			14.0 °CWB		16.0 °CWB		18.0 °CWB		19.0 °CWB		20.0 °CWB		22.0 °CWB		24.0 °CWB	
			20.0 °CDB		23.0 °CDB		16.0 °CDB		27.0 °CDB		28.0 °CDB		30.0 °CDB		32.0 °CDB	
			TC	PI	TC	PI	TC	PI	TC	PI	TC	PI	TC	PI	TC	PI
130	455 (52.00)	10	21.1	2.79	25.1	3.27	29.2	3.75	31.2	3.99	33.2	4.23	37.3	4.70	41.3	5.15
		12	21.1	2.83	25.1	3.32	29.2	3.81	31.2	4.05	33.2	4.29	37.3	4.77	41.3	5.39
		14	21.1	2.87	25.1	3.37	29.2	3.86	31.2	4.11	33.2	4.36	37.3	5.02	41.3	5.82
		16	21.1	2.91	25.1	3.42	29.2	3.93	31.2	4.24	33.2	4.61	37.3	5.41	41.3	6.28
		18	21.1	2.96	25.1	3.47	29.2	4.16	31.2	4.55	33.2	4.95	37.3	5.82	41.3	6.75
		20	21.1	3.00	25.1	3.68	29.2	4.5	31.2	4.9	33.2	5.3	37.3	6.2	41.3	7.3
		21	21.1	3.08	25.1	3.81	29.2	4.6	31.2	5.0	33.2	5.5	37.3	6.5	41.3	7.5
		23	21.1	3.28	25.1	4.06	29.2	4.9	31.2	5.4	33.2	5.9	37.3	6.9	41.3	8.1
		25	21.1	3.50	25.1	4.3	29.2	5.3	31.2	5.8	33.2	6.3	37.3	7.4	41.3	8.6
		27	21.1	3.72	25.1	4.6	29.2	5.6	31.2	6.2	33.2	6.7	37.3	7.9	41.3	9.2
		29	21.1	3.95	25.1	4.9	29.2	6.0	31.2	6.6	33.2	7.2	37.3	8.5	41.3	9.9
		31	21.1	4.19	25.1	5.2	29.2	6.4	31.2	7.0	33.2	7.6	37.3	9.0	41.3	10.5
33	21.1	4.4	25.1	5.6	29.2	6.8	31.2	7.4	33.2	8.1	37.3	9.6	41.3	11.2		
35	21.1	4.7	25.1	5.9	29.2	7.2	31.2	7.9	33.2	8.7	37.3	10.3	41.3	12.0		
37	21.1	5.0	25.1	6.3	29.2	7.7	31.2	8.4	33.2	9.2	37.3	10.9	41.3	12.4		
39	21.1	5.3	25.1	6.6	29.2	8.1	31.2	9.0	33.2	9.8	37.3	11.6	41.3	12.8		
120	420 (48.00)	10	19.4	2.60	23.2	3.04	26.9	3.48	28.8	3.71	30.7	3.93	34.4	4.37	38.2	4.80
		12	19.4	2.64	23.2	3.08	26.9	3.53	28.8	3.76	30.7	3.99	34.4	4.43	38.2	4.87
		14	19.4	2.68	23.2	3.13	26.9	3.59	28.8	3.82	30.7	4.05	34.4	4.50	38.2	5.19
		16	19.4	2.72	23.2	3.18	26.9	3.64	28.8	3.88	30.7	4.14	34.4	4.84	38.2	5.59
		18	19.4	2.76	23.2	3.23	26.9	3.75	28.8	4.09	30.7	4.45	34.4	5.20	38.2	6.02
		20	19.4	2.80	23.2	3.34	26.9	4.02	28.8	4.4	30.7	4.8	34.4	5.6	38.2	6.5
		21	19.4	2.82	23.2	3.45	26.9	4.16	28.8	4.5	30.7	4.9	34.4	5.8	38.2	6.7
		23	19.4	3.00	23.2	3.68	26.9	4.4	28.8	4.8	30.7	5.3	34.4	6.2	38.2	7.2
		25	19.4	3.19	23.2	3.92	26.9	4.7	28.8	5.2	30.7	5.6	34.4	6.6	38.2	7.7
		27	19.4	3.39	23.2	4.18	26.9	5.1	28.8	5.5	30.7	6.0	34.4	7.1	38.2	8.2
		29	19.4	3.60	23.2	4.4	26.9	5.4	28.8	5.9	30.7	6.4	34.4	7.5	38.2	8.8
		31	19.4	3.81	23.2	4.7	26.9	5.7	28.8	6.3	30.7	6.8	34.4	8.0	38.2	9.3
33	19.4	4.04	23.2	5.0	26.9	6.1	28.8	6.7	30.7	7.3	34.4	8.6	38.2	10.0		
35	19.4	4.28	23.2	5.3	26.9	6.5	28.8	7.1	30.7	7.7	34.4	9.1	38.2	10.6		
37	19.4	4.5	23.2	5.6	26.9	6.9	28.8	7.5	30.7	8.2	34.4	9.7	38.2	11.3		
39	19.4	4.8	23.2	6.0	26.9	7.3	28.8	8.0	30.7	8.7	34.4	10.3	38.2	12.1		
110	385 (44.00)	10	17.8	2.42	21.3	2.81	24.7	3.22	26.4	3.42	28.1	3.62	31.5	4.03	35.0	4.44
		12	17.8	2.45	21.3	2.85	24.7	3.26	26.4	3.47	28.1	3.68	31.5	4.09	35.0	4.50
		14	17.8	2.48	21.3	2.89	24.7	3.31	26.4	3.52	28.1	3.74	31.5	4.16	35.0	4.60
		16	17.8	2.52	21.3	2.94	24.7	3.36	26.4	3.58	28.1	3.79	31.5	4.30	35.0	4.95
		18	17.8	2.56	21.3	2.98	24.7	3.42	26.4	3.66	28.1	3.97	31.5	4.62	35.0	5.32
		20	17.8	2.59	21.3	3.03	24.7	3.60	26.4	3.92	28.1	4.2	31.5	5.0	35.0	5.7
		21	17.8	2.61	21.3	3.11	24.7	3.73	26.4	4.05	28.1	4.4	31.5	5.1	35.0	5.9
		23	17.8	2.72	21.3	3.32	24.7	3.98	26.4	4.3	28.1	4.7	31.5	5.5	35.0	6.3
		25	17.8	2.89	21.3	3.53	24.7	4.2	26.4	4.6	28.1	5.0	31.5	5.9	35.0	6.8
		27	17.8	3.07	21.3	3.76	24.7	4.5	26.4	4.9	28.1	5.3	31.5	6.2	35.0	7.2
		29	17.8	3.26	21.3	3.99	24.7	4.8	26.4	5.2	28.1	5.7	31.5	6.7	35.0	7.7
		31	17.8	3.45	21.3	4.24	24.7	5.1	26.4	5.6	28.1	6.1	31.5	7.1	35.0	8.2
33	17.8	3.66	21.3	4.5	24.7	5.4	26.4	5.9	28.1	6.4	31.5	7.6	35.0	8.8		
35	17.8	3.87	21.3	4.8	24.7	5.8	26.4	6.3	28.1	6.9	31.5	8.0	35.0	9.3		
37	17.8	4.10	21.3	5.1	24.7	6.1	26.4	6.7	28.1	7.3	31.5	8.6	35.0	9.9		
39	17.8	4.33	21.3	5.4	24.7	6.5	26.4	7.1	28.1	7.7	31.5	9.1	35.0	10.6		
100	350 (40.00)	10	16.2	2.24	19.3	2.59	22.4	2.95	24.0	3.13	25.6	3.32	28.7	3.69	31.8	4.06
		12	16.2	2.27	19.3	2.62	22.4	2.99	24.0	3.18	25.6	3.37	28.7	3.75	31.8	4.12
		14	16.2	2.30	19.3	2.66	22.4	3.04	24.0	3.23	25.6	3.42	28.7	3.80	31.8	4.19
		16	16.2	2.33	19.3	2.70	22.4	3.08	24.0	3.28	25.6	3.47	28.7	3.86	31.8	4.35
		18	16.2	2.36	19.3	2.74	22.4	3.13	24.0	3.33	25.6	3.53	28.7	4.07	31.8	4.67
		20	16.2	2.39	19.3	2.78	22.4	3.21	24.0	3.48	25.6	3.76	28.7	4.4	31.8	5.0
		21	16.2	2.41	19.3	2.80	22.4	3.32	24.0	3.60	25.6	3.89	28.7	4.5	31.8	5.2
		23	16.2	2.46	19.3	2.98	22.4	3.54	24.0	3.84	25.6	4.16	28.7	4.8	31.8	5.5
		25	16.2	2.62	19.3	3.17	22.4	3.77	24.0	4.09	25.6	4.4	28.7	5.1	31.8	5.9
		27	16.2	2.78	19.3	3.36	22.4	4.01	24.0	4.4	25.6	4.7	28.7	5.5	31.8	6.3
		29	16.2	2.94	19.3	3.57	22.4	4.27	24.0	4.6	25.6	5.0	28.7	5.8	31.8	6.7
		31	16.2	3.11	19.3	3.79	22.4	4.5	24.0	4.9	25.6	5.3	28.7	6.2	31.8	7.2
33	16.2	3.29	19.3	4.01	22.4	4.8	24.0	5.2	25.6	5.7	28.7	6.6	31.8	7.6		
35	16.2	3.48	19.3	4.25	22.4	5.1	24.0	5.6	25.6	6.0	28.7	7.0	31.8	8.1		
37	16.2	3.68	19.3	4.5	22.4	5.4	24.0	5.9	25.6	6.4	28.7	7.5	31.8	8.7		
39	16.2	3.89	19.3	4.8	22.4	5.7	24.0	6.3	25.6	6.8	28.7	8.0	31.8	9.2		

4TW33912-3A(9)

4 Capacity tables

4 - 1 Cooling Capacity Tables

RXYRQ14P - Correction factor for mixed connection: 0.6

TC: Total Capacity: kW ; PI: Power Input: kW (compressor + outdoor fan motor)

Combination (%)	Capacity index (kW)	Outdoor air temp. °CDB	Indoor air temperature:															
			14.0 °CWB		16.0 °CWB		18.0 °CWB		19.0 °CWB		20.0 °CWB		22.0 °CWB		24.0 °CWB			
			20.0 °CDB		23.0 °CDB		16.0 °CDB		27.0 °CDB		28.0 °CDB		30.0 °CDB		32.0 °CDB			
			TC	PI	TC	PI	TC	PI	TC	PI	TC	PI	TC	PI	TC	PI		
90	315 (36.00)	10	14,6	2,06	17,4	2,37	20,2	2,69	21,6	2,85	23,0	3,02	25,8	3,35	28,6	3,68		
		12	14,6	2,09	17,4	2,40	20,2	2,73	21,6	2,89	23,0	3,06	25,8	3,40	28,6	3,74		
		14	14,6	2,11	17,4	2,43	20,2	2,77	21,6	2,94	23,0	3,11	25,8	3,45	28,6	3,80		
		16	14,6	2,14	17,4	2,47	20,2	2,81	21,6	2,98	23,0	3,15	25,8	3,50	28,6	3,86		
		18	14,6	2,17	17,4	2,50	20,2	2,85	21,6	3,03	23,0	3,20	25,8	3,56	28,6	4,06		
		20	14,6	2,20	17,4	2,54	20,2	2,89	21,6	3,07	23,0	3,31	25,8	3,81	28,6	4,3		
		21	14,6	2,21	17,4	2,56	20,2	2,94	21,6	3,17	23,0	3,42	25,8	3,94	28,6	4,5		
		23	14,6	2,25	17,4	2,65	20,2	3,13	21,6	3,38	23,0	3,65	25,8	4,2	28,6	4,8		
		25	14,6	2,35	17,4	2,82	20,2	3,33	21,6	3,60	23,0	3,89	25,8	4,5	28,6	5,1		
		27	14,6	2,49	17,4	2,99	20,2	3,54	21,6	3,83	23,0	4,14	25,8	4,8	28,6	5,5		
		29	14,6	2,64	17,4	3,17	20,2	3,76	21,6	4,07	23,0	4,4	25,8	5,1	28,6	5,8		
		31	14,6	2,79	17,4	3,36	20,2	3,99	21,6	4,3	23,0	4,7	25,8	5,4	28,6	6,2		
		33	14,6	2,95	17,4	3,56	20,2	4,23	21,6	4,6	23,0	5,0	25,8	5,8	28,6	6,6		
		35	14,6	3,12	17,4	3,77	20,2	4,5	21,6	4,9	23,0	5,3	25,8	6,1	28,6	7,0		
		37	14,6	3,29	17,4	3,98	20,2	4,7	21,6	5,2	23,0	5,6	25,8	6,5	28,6	7,5		
		39	14,6	3,47	17,4	4,21	20,2	5,0	21,6	5,5	23,0	5,9	25,8	6,9	28,6	7,9		
		80	280 (32.00)	10	13,0	1,89	15,5	2,16	18,0	2,43	19,2	2,58	20,4	2,72	22,9	3,01	25,4	3,31
				12	13,0	1,91	15,5	2,18	18,0	2,47	19,2	2,61	20,4	2,76	22,9	3,05	25,4	3,35
				14	13,0	1,93	15,5	2,21	18,0	2,50	19,2	2,65	20,4	2,80	22,9	3,10	25,4	3,41
16	13,0			1,96	15,5	2,24	18,0	2,54	19,2	2,69	20,4	2,84	22,9	3,15	25,4	3,46		
18	13,0			1,98	15,5	2,27	18,0	2,57	19,2	2,73	20,4	2,88	22,9	3,20	25,4	3,51		
20	13,0			2,01	15,5	2,30	18,0	2,61	19,2	2,77	20,4	2,93	22,9	3,30	25,4	3,74		
21	13,0			2,02	15,5	2,32	18,0	2,63	19,2	2,79	20,4	2,98	22,9	3,41	25,4	3,87		
23	13,0			2,05	15,5	2,35	18,0	2,75	19,2	2,96	20,4	3,17	22,9	3,64	25,4	4,13		
25	13,0			2,11	15,5	2,49	18,0	2,92	19,2	3,14	20,4	3,38	22,9	3,87	25,4	4,4		
27	13,0			2,23	15,5	2,64	18,0	3,10	19,2	3,34	20,4	3,59	22,9	4,12	25,4	4,7		
29	13,0			2,36	15,5	2,80	18,0	3,29	19,2	3,55	20,4	3,81	22,9	4,4	25,4	5,0		
31	13,0			2,49	15,5	2,96	18,0	3,48	19,2	3,76	20,4	4,05	22,9	4,7	25,4	5,3		
33	13,0			2,63	15,5	3,13	18,0	3,69	19,2	3,99	20,4	4,29	22,9	4,9	25,4	5,6		
35	13,0			2,77	15,5	3,31	18,0	3,91	19,2	4,22	20,4	4,6	22,9	5,2	25,4	6,0		
37	13,0			2,92	15,5	3,50	18,0	4,13	19,2	4,47	20,4	4,8	22,9	5,6	25,4	6,4		
39	13,0			3,08	15,5	3,69	18,0	4,37	19,2	4,73	20,4	5,1	22,9	5,9	25,4	6,8		

4TW33912-3A(10)

NOTES - ANMERKUNGEN - Σημειώσεις - NOTAS - REMARQUES - NOTE - OPMERKINGEN - Примечания - NOTLAR

- The above table shows the average value of conditions which may occur.
Die obige Tabelle zeigt den Durchschnittswert der Bedingungen, die auftreten können.
Στον παραπάνω πίνακα αναγράφεται η μέση τιμή για συνθήκες που μπορεί να προκύψουν.
La tabla de arriba muestra el valor medio de condiciones que pueden ocurrir.
Le tableau ci-dessus donne la valeur moyenne pour des conditions qui peuvent survenir.
La tabella in alto mostra il valore delle condizioni medie che si possono riscontrare.
De tabel hierboven geeft de gemiddelde waarde aan van situaties die kunnen voorvallen.
Таблица расположенная выше показывает среднее значение условий, которые могут наступить.
Yukarıdaki tablo meydana gelebilecek koşulların ortalama değerini göstermektedir.
- Correction factor for mixed connection: 0.6. For more information refer to the selection procedure.
Korrekturfaktoren für gemischten Anschluss: 0,6. Weitere Informationen finden Sie im Auswahlverfahren.
Συντελεστής διόρθωσης για συνδυαζόμενη σύνδεση: 0,6. Για περισσότερες πληροφορίες ανατρέξτε στη διαδικασία επιλογής.
Factor de corrección para conexión combinada: 0,6. Si desea más información, consulte el procedimiento de selección.
Facteur de correction pour connexion d'unités mixtes : 0,6. Pour plus d'informations, se reporter à la procédure de sélection.
Fattore di correzione per collegamento varie unità: 0,6. Per maggiori informazioni fare riferimento alla procedura di selezione.
Correctiefactor voor gemengde aansluiting: 0,6. Zie selectieprocedure voor meer informatie.
Поправочный коэффициент для комбинированного соединения: 0,6. Подробная информация приводится в разделе порядка выбора.
Karışık bağlantı için düzeltme faktörü: 0.6. Daha fazla bilgi için, seçim prosedürüne bakın.

4 Capacity tables

4 - 1 Cooling Capacity Tables

RXYRQ16P - Correction factor for mixed connection: 1.0																		
TC: Total Capacity: kW ; PI: Power Input: kW (compressor + outdoor fan motor)																		
Combination (%)	Capacity index (kW)	Outdoor air temp. °CDB	Indoor air temperature:															
			14.0 °CWB		16.0 °CWB		18.0 °CWB		19.0 °CWB		20.0 °CWB		22.0 °CWB		24.0 °CWB			
			20.0 °CDB		23.0 °CDB		16.0 °CDB		27.0 °CDB		28.0 °CDB		30.0 °CDB		32.0 °CDB			
			TC	PI	TC	PI	TC	PI	TC	PI	TC	PI	TC	PI	TC	PI		
130	520 (58.50)	10	39.5	6.22	47.1	7.61	54.7	9.1	56.7	9.2	57.4	9.1	58.8	8.7	60.2	8.28		
		12	39.5	6.33	47.1	7.75	54.7	9.2	55.9	9.2	56.7	9.0	58.1	8.6	59.5	8.5		
		14	39.5	6.45	47.1	7.90	54.5	9.3	55.2	9.1	55.9	9.0	57.3	8.9	58.8	9.0		
		16	39.5	6.57	47.1	8.06	53.8	9.3	54.5	9.2	55.2	9.3	56.6	9.4	58.0	9.4		
		18	39.5	6.70	47.1	8.22	53.0	9.6	53.7	9.7	54.5	9.7	55.9	9.8	57.3	9.9		
		20	39.5	6.84	47.1	8.8	52.3	10.1	53.0	10.2	53.7	10.2	55.2	10.3	56.6	10.4		
		21	39.5	7.03	47.1	9.1	51.9	10.4	52.7	10.4	53.4	10.5	54.8	10.6	56.2	10.7		
		23	39.5	7.52	47.1	9.7	51.2	10.8	51.9	10.9	52.6	10.9	54.1	11.0	55.5	11.2		
		25	39.5	8.05	47.1	10.4	50.5	11.3	51.2	11.4	51.9	11.4	53.3	11.5	54.7	11.7		
		27	39.5	8.6	47.1	11.1	49.7	11.8	50.5	11.8	51.2	11.9	52.6	12.0	54.0	12.1		
		29	39.5	9.2	47.1	11.9	49.0	12.3	49.7	12.3	50.4	12.4	51.9	12.5	53.3	12.6		
		31	39.5	9.8	46.9	12.6	48.3	12.7	49.0	12.8	49.7	12.9	51.1	13.0	52.5	13.1		
		33	39.5	10.4	46.1	13.1	47.5	13.2	48.3	13.3	49.0	13.4	50.4	13.5	51.8	13.7		
		35	39.5	11.1	45.4	13.5	46.8	13.7	47.5	13.8	48.2	13.9	49.7	14.0	51.1	14.2		
		37	39.5	11.8	44.7	14.0	46.1	14.2	46.8	14.3	47.5	14.3	48.9	14.5	50.4	14.7		
		39	39.5	12.6	43.9	14.5	45.4	14.7	46.1	14.8	46.8	14.8	48.2	15.0	49.6	15.2		
		120	480 (54.00)	10	36.4	5.68	43.5	6.94	50.5	8.25	54.0	8.9	56.5	9.3	57.8	8.9	59.1	8.6
				12	36.4	5.78	43.5	7.07	50.5	8.41	54.0	9.1	55.8	9.2	57.1	8.9	58.4	8.5
14	36.4			5.89	43.5	7.20	50.5	8.6	54.0	9.3	55.0	9.2	56.3	8.8	57.7	8.9		
16	36.4			6.00	43.5	7.34	50.5	8.7	53.6	9.3	54.3	9.2	55.6	9.3	56.9	9.4		
18	36.4			6.12	43.5	7.49	50.5	9.0	52.9	9.6	53.6	9.7	54.9	9.8	56.2	9.9		
20	36.4			6.24	43.5	7.78	50.5	9.7	52.2	10.1	52.8	10.2	54.1	10.2	55.5	10.3		
21	36.4			6.30	43.5	8.06	50.5	10.1	51.8	10.3	52.5	10.4	53.8	10.5	55.1	10.6		
23	36.4			6.73	43.5	8.6	50.4	10.8	51.1	10.8	51.7	10.9	53.0	11.0	54.4	11.1		
25	36.4			7.19	43.5	9.2	49.7	11.2	50.3	11.3	51.0	11.3	52.3	11.5	53.6	11.6		
27	36.4			7.68	43.5	9.9	49.0	11.7	49.6	11.8	50.3	11.8	51.6	11.9	52.9	12.1		
29	36.4			8.19	43.5	10.6	48.2	12.2	48.9	12.2	49.5	12.3	50.9	12.4	52.2	12.5		
31	36.4			8.7	43.5	11.3	47.5	12.7	48.1	12.7	48.8	12.8	50.1	12.9	51.4	13.0		
33	36.4			9.3	43.5	12.0	46.8	13.1	47.4	13.2	48.1	13.3	49.4	13.4	50.7	13.5		
35	36.4			9.9	43.5	12.8	46.0	13.6	46.7	13.7	47.3	13.8	48.7	13.9	50.0	14.0		
37	36.4			10.5	43.5	13.7	45.3	14.1	46.0	14.2	46.6	14.2	47.9	14.4	49.2	14.5		
39	36.4			11.2	43.2	14.4	44.6	14.6	45.2	14.7	45.9	14.7	47.2	14.9	48.5	15.1		
110	440 (49.50)			10	33.4	5.16	39.8	6.28	46.3	7.46	49.5	8.06	52.7	8.7	56.8	9.2	58.0	8.9
				12	33.4	5.25	39.8	6.40	46.3	7.60	49.5	8.21	52.7	8.8	56.1	9.2	57.3	8.8
		14	33.4	5.35	39.8	6.52	46.3	7.74	49.5	8.37	52.7	9.0	55.3	9.1	56.5	8.8		
		16	33.4	5.45	39.8	6.64	46.3	7.90	49.5	8.5	52.7	9.2	54.6	9.2	55.8	9.3		
		18	33.4	5.55	39.8	6.77	46.3	8.05	49.5	8.8	52.7	9.6	53.9	9.7	55.1	9.8		
		20	33.4	5.66	39.8	6.91	46.3	8.5	49.5	9.4	51.9	10.1	53.1	10.2	54.3	10.3		
		21	33.4	5.71	39.8	7.12	46.3	8.8	49.5	9.8	51.6	10.3	52.8	10.4	54.0	10.5		
		23	33.4	5.98	39.8	7.62	46.3	9.5	49.5	10.5	50.8	10.8	52.0	10.9	53.2	11.0		
		25	33.4	6.39	39.8	8.15	46.3	10.1	49.5	11.2	50.1	11.3	51.3	11.4	52.5	11.5		
		27	33.4	6.81	39.8	8.7	46.3	10.8	48.8	11.7	49.4	11.7	50.6	11.8	51.8	12.0		
		29	33.4	7.26	39.8	9.3	46.3	11.6	48.0	12.2	48.6	12.2	49.8	12.3	51.0	12.4		
		31	33.4	7.73	39.8	9.9	46.3	12.4	47.3	12.6	47.9	12.7	49.1	12.8	50.3	12.9		
		33	33.4	8.23	39.8	10.6	46.0	13.1	46.6	13.1	47.2	13.2	48.4	13.3	49.6	13.4		
		35	33.4	8.8	39.8	11.3	45.2	13.5	45.8	13.6	46.4	13.7	47.6	13.8	48.9	13.9		
		37	33.4	9.3	39.8	12.0	44.5	14.0	45.1	14.1	45.7	14.1	46.9	14.3	48.1	14.4		
		39	33.4	9.9	39.8	12.8	43.8	14.5	44.4	14.6	45.0	14.6	46.2	14.8	47.4	14.9		
		100	400 (45.00)	10	30.4	4.65	36.2	5.64	42.1	6.68	45.0	7.22	47.9	7.77	53.8	8.9	56.9	9.2
				12	30.4	4.73	36.2	5.74	42.1	6.81	45.0	7.36	47.9	7.91	53.8	9.0	56.2	9.1
14	30.4			4.82	36.2	5.85	42.1	6.94	45.0	7.50	47.9	8.06	53.8	9.2	55.4	9.1		
16	30.4			4.90	36.2	5.96	42.1	7.07	45.0	7.64	47.9	8.22	53.6	9.3	54.7	9.2		
18	30.4			5.00	36.2	6.08	42.1	7.21	45.0	7.79	47.9	8.39	52.9	9.6	54.0	9.7		
20	30.4			5.09	36.2	6.20	42.1	7.43	45.0	8.19	47.9	9.0	52.1	10.1	53.2	10.2		
21	30.4			5.14	36.2	6.26	42.1	7.69	45.0	8.5	47.9	9.3	51.8	10.3	52.9	10.4		
23	30.4			5.28	36.2	6.67	42.1	8.24	45.0	9.1	47.9	10.0	51.0	10.8	52.1	10.9		
25	30.4			5.63	36.2	7.13	42.1	8.8	45.0	9.7	47.9	10.7	50.3	11.3	51.4	11.4		
27	30.4			6.00	36.2	7.61	42.1	9.4	45.0	10.4	47.9	11.4	49.6	11.8	50.7	11.9		
29	30.4			6.39	36.2	8.12	42.1	10.1	45.0	11.1	47.7	12.1	48.8	12.2	49.9	12.3		
31	30.4			6.80	36.2	8.7	42.1	10.7	45.0	11.9	47.0	12.6	48.1	12.7	49.2	12.8		
33	30.4			7.23	36.2	9.2	42.1	11.4	45.0	12.7	46.3	13.1	47.4	13.2	48.5	13.3		
35	30.4			7.68	36.2	9.8	42.1	12.2	45.0	13.5	45.5	13.6	46.6	13.7	47.7	13.8		
37	30.4			8.16	36.2	10.4	42.1	13.0	44.3	14.0	44.8	14.0	45.9	14.2	47.0	14.3		
39	30.4			8.7	36.2	11.1	42.1	13.8	43.5	14.5	44.1	14.5	45.2	14.7	46.3	14.8		

4TW33912-3A(1)

4 Capacity tables

4 - 1 Cooling Capacity Tables

RXYRQ16P - Correction factor for mixed connection: 1.0

TC: Total Capacity: kW ; PI: Power Input: kW (compressor + outdoor fan motor)

Combination (%)	Capacity index (kW)	Outdoor air temp. °CDB	Indoor air temperature:															
			14.0 °CWB		16.0 °CWB		18.0 °CWB		19.0 °CWB		20.0 °CWB		22.0 °CWB		24.0 °CWB			
			20.0 °CDB		23.0 °CDB		16.0 °CDB		27.0 °CDB		28.0 °CDB		30.0 °CDB		32.0 °CDB			
			TC	PI	TC	PI	TC	PI	TC	PI	TC	PI	TC	PI	TC	PI		
90	360 (40.50)	10	27.3	4.16	32.6	5.02	37.9	5.93	40.5	6.40	43.1	6.88	48.4	7.86	53.7	8.9		
		12	27.3	4.23	32.6	5.11	37.9	6.04	40.5	6.52	43.1	7.01	48.4	8.00	53.7	9.0		
		14	27.3	4.31	32.6	5.20	37.9	6.15	40.5	6.64	43.1	7.14	48.4	8.16	53.7	9.2		
		16	27.3	4.38	32.6	5.30	37.9	6.27	40.5	6.77	43.1	7.28	48.4	8.32	53.6	9.3		
		18	27.3	4.46	32.6	5.40	37.9	6.39	40.5	6.90	43.1	7.42	48.4	8.5	52.8	9.6		
		20	27.3	4.54	32.6	5.50	37.9	6.52	40.5	7.04	43.1	7.70	48.4	9.1	52.1	10.1		
		21	27.3	4.59	32.6	5.56	37.9	6.63	40.5	7.29	43.1	7.97	48.4	9.4	51.7	10.3		
		23	27.3	4.67	32.6	5.79	37.9	7.10	40.5	7.80	43.1	8.5	48.4	10.1	51.0	10.8		
		25	27.3	4.92	32.6	6.18	37.9	7.59	40.5	8.34	43.1	9.1	48.4	10.8	50.3	11.3		
		27	27.3	5.24	32.6	6.59	37.9	8.10	40.5	8.9	43.1	9.8	48.4	11.6	49.5	11.8		
		29	27.3	5.58	32.6	7.02	37.9	8.6	40.5	9.5	43.1	10.4	47.8	12.1	48.8	12.2		
		31	27.3	5.93	32.6	7.48	37.9	9.2	40.5	10.2	43.1	11.1	47.1	12.6	48.1	12.7		
		33	27.3	6.30	32.6	7.96	37.9	9.8	40.5	10.8	43.1	11.9	46.4	13.1	47.4	13.2		
		35	27.3	6.69	32.6	8.5	37.9	10.5	40.5	11.5	43.1	12.7	45.6	13.6	46.6	13.7		
		37	27.3	7.10	32.6	9.0	37.9	11.1	40.5	12.3	43.1	13.5	44.9	14.0	45.9	14.2		
		39	27.3	7.53	32.6	9.6	37.9	11.8	40.5	13.1	43.1	14.4	44.2	14.5	45.2	14.6		
		80	320 (36.00)	10	24.3	3.70	29.0	4.43	33.7	5.20	36.0	5.60	38.3	6.01	43.0	6.86	47.7	7.72
				12	24.3	3.76	29.0	4.50	33.7	5.29	36.0	5.70	38.3	6.12	43.0	6.99	47.7	7.87
14	24.3			3.82	29.0	4.58	33.7	5.39	36.0	5.81	38.3	6.24	43.0	7.12	47.7	8.02		
16	24.3			3.88	29.0	4.66	33.7	5.49	36.0	5.92	38.3	6.36	43.0	7.26	47.7	8.18		
18	24.3			3.95	29.0	4.75	33.7	5.60	36.0	6.03	38.3	6.48	43.0	7.40	47.7	8.34		
20	24.3			4.02	29.0	4.84	33.7	5.70	36.0	6.15	38.3	6.61	43.0	7.67	47.7	8.9		
21	24.3			4.06	29.0	4.88	33.7	5.76	36.0	6.21	38.3	6.75	43.0	7.94	47.7	9.2		
23	24.3			4.13	29.0	4.98	33.7	6.04	36.0	6.62	38.3	7.22	43.0	8.5	47.7	9.9		
25	24.3			4.27	29.0	5.30	33.7	6.45	36.0	7.07	38.3	7.72	43.0	9.1	47.7	10.6		
27	24.3			4.54	29.0	5.65	33.7	6.88	36.0	7.55	38.3	8.24	43.0	9.7	47.7	11.4		
29	24.3			4.82	29.0	6.01	33.7	7.34	36.0	8.05	38.3	8.8	43.0	10.4	47.7	12.1		
31	24.3			5.12	29.0	6.39	33.7	7.81	36.0	8.6	38.3	9.4	43.0	11.1	47.0	12.6		
33	24.3			5.43	29.0	6.79	33.7	8.32	36.0	9.1	38.3	10.0	43.0	11.8	46.2	13.1		
35	24.3			5.76	29.0	7.22	33.7	8.8	36.0	9.7	38.3	10.6	43.0	12.6	45.5	13.6		
37	24.3			6.11	29.0	7.66	33.7	9.4	36.0	10.3	38.3	11.3	43.0	13.4	44.8	14.0		
39	24.3			6.47	29.0	8.14	33.7	10.0	36.0	11.0	38.3	12.1	43.0	14.3	44.0	14.5		

4TW33912-3A(2)

NOTES - ANMERKUNGEN - Σημειώσεις - NOTAS - REMARQUES - NOTE - OPMERKINGEN - Примечания - NOTLAR

- The above table shows the average value of conditions which may occur.
Die obige Tabelle zeigt den Durchschnittswert der Bedingungen, die auftreten können.
Στον παραπάνω πίνακα αναγράφεται η μέση τιμή για συνθήκες που μπορεί να προκύψουν.
La tabla de arriba muestra el valor medio de condiciones que pueden ocurrir.
Le tableau ci-dessus donne la valeur moyenne pour des conditions qui peuvent survenir.
La tabella in alto mostra il valore delle condizioni medie che si possono riscontrare.
De tabel hierboven geeft de gemiddelde waarde aan van situaties die kunnen voorvallen.
Таблица расположенная выше показывает среднее значение условий, которые могут наступить.
Yukarıdaki tablo meydana gelebilecek koşulların ortalama değerini göstermektedir.
- Correction factor for mixed connection: 1.0. For more information refer to the selection procedure.
Korrekturfaktoren für gemischten Anschluss: 1,0. Weitere Informationen finden Sie im Auswahlverfahren.
Συντελεστής διόρθωσης για συνδυαζόμενη σύνδεση: 1,0. Για περισσότερες πληροφορίες ανατρέξτε στη διαδικασία επιλογής.
Factor de corrección para conexión combinada: 1,0. Si desea más información, consulte el procedimiento de selección.
Facteur de correction pour connexion d'unités mixtes : 1,0. Pour plus d'informations, se reporter à la procédure de sélection.
Fattore di correzione per collegamento varie unità: 1,0. Per maggiori informazioni fare riferimento alla procedura di selezione.
Correctiefactor voor gemengde aansluiting: 1,0. Zie selectieprocedure voor meer informatie.
Поправочный коэффициент для комбинированного соединения: 1,0. Подробная информация приводится в разделе порядка выбора.
Karışık bağlantı için düzeltme faktörü: 1.0. Daha fazla bilgi için, seçim prosedürüne bakın.

4 Capacity tables

4 - 1 Cooling Capacity Tables

RXYRQ16P - Correction factor for mixed connection: 0.9																
TC: Total Capacity: kW ; PI: Power Input: kW (compressor + outdoor fan motor)																
Combination (%)	Capacity index (kW)	Outdoor air temp. °CDB	Indoor air temperature:													
			14.0 °CWB		16.0 °CWB		18.0 °CWB		19.0 °CWB		20.0 °CWB		22.0 °CWB		24.0 °CWB	
			20.0 °CDB		23.0 °CDB		16.0 °CDB		27.0 °CDB		28.0 °CDB		30.0 °CDB		32.0 °CDB	
			TC	PI	TC	PI	TC	PI	TC	PI	TC	PI	TC	PI	TC	PI
130	520 (58.50)	10	35.5	5.40	42.4	6.55	49.2	7.7	52.7	8.3	56.1	8.9	58.8	8.7	60.2	8.28
		12	35.5	5.49	42.4	6.67	49.2	7.9	52.7	8.5	56.1	9.0	58.1	8.6	59.5	8.5
		14	35.5	5.59	42.4	6.79	49.2	8.0	52.7	8.6	55.9	9.0	57.3	8.9	58.8	9.0
		16	35.5	5.70	42.4	6.92	49.2	8.2	52.7	8.9	55.2	9.3	56.6	9.4	58.0	9.4
		18	35.5	5.80	42.4	7.05	49.2	8.7	52.7	9.6	54.5	9.7	55.9	9.8	57.3	9.9
		20	35.5	5.91	42.4	7.5	49.2	9.3	52.7	10.2	53.7	10.2	55.2	10.3	56.6	10.4
		21	35.5	6.08	42.4	7.8	49.2	9.7	52.7	10.4	53.4	10.5	54.8	10.6	56.2	10.7
		23	35.5	6.50	42.4	8.3	49.2	10.4	51.9	10.9	52.6	10.9	54.1	11.0	55.5	11.2
		25	35.5	6.94	42.4	8.9	49.2	11.1	51.2	11.4	51.9	11.4	53.3	11.5	54.7	11.7
		27	35.5	7.4	42.4	9.5	49.2	11.8	50.5	11.8	51.2	11.9	52.6	12.0	54.0	12.1
		29	35.5	7.9	42.4	10.2	49.0	12.3	49.7	12.3	50.4	12.4	51.9	12.5	53.3	12.6
		31	35.5	8.4	42.4	10.9	48.3	12.7	49.0	12.8	49.7	12.9	51.1	13.0	52.5	13.1
		33	35.5	9.0	42.4	11.6	47.5	13.2	48.3	13.3	49.0	13.4	50.4	13.5	51.8	13.7
		35	35.5	9.5	42.4	12.3	46.8	13.7	47.5	13.8	48.2	13.9	49.7	14.0	51.1	14.2
		37	35.5	10.2	42.4	13.1	46.1	14.2	46.8	14.3	47.5	14.3	48.9	14.5	50.4	14.7
		39	35.5	10.8	42.4	14.0	45.4	14.7	46.1	14.8	46.8	14.8	48.2	15.0	49.6	15.2
120	480 (54.00)	10	32.8	4.95	39.1	6.00	45.4	7.08	48.6	7.6	51.8	8.2	57.8	8.9	59.1	8.6
		12	32.8	5.04	39.1	6.10	45.4	7.21	48.6	7.8	51.8	8.3	57.1	8.9	58.4	8.5
		14	32.8	5.13	39.1	6.22	45.4	7.3	48.6	7.9	51.8	8.5	56.3	8.8	57.7	8.9
		16	32.8	5.22	39.1	6.33	45.4	7.5	48.6	8.1	51.8	8.7	55.6	9.3	56.9	9.4
		18	32.8	5.32	39.1	6.45	45.4	7.7	48.6	8.5	51.8	9.4	54.9	9.8	56.2	9.9
		20	32.8	5.42	39.1	6.70	45.4	8.3	48.6	9.2	51.8	10.1	54.1	10.2	55.5	10.3
		21	32.8	5.47	39.1	6.94	45.4	8.6	48.6	9.5	51.8	10.4	53.8	10.5	55.1	10.6
		23	32.8	5.84	39.1	7.4	45.4	9.2	48.6	10.2	51.7	10.9	53.0	11.0	54.4	11.1
		25	32.8	6.23	39.1	7.9	45.4	9.9	48.6	10.9	51.0	11.3	52.3	11.5	53.6	11.6
		27	32.8	6.65	39.1	8.5	45.4	10.6	48.6	11.7	50.3	11.8	51.6	11.9	52.9	12.1
		29	32.8	7.08	39.1	9.1	45.4	11.3	48.6	12.2	49.5	12.3	50.9	12.4	52.2	12.5
		31	32.8	7.5	39.1	9.7	45.4	12.0	48.1	12.7	48.8	12.8	50.1	12.9	51.4	13.0
		33	32.8	8.0	39.1	10.3	45.4	12.8	47.4	13.2	48.1	13.3	49.4	13.4	50.7	13.5
		35	32.8	8.5	39.1	11.0	45.4	13.6	46.7	13.7	47.3	13.8	48.7	13.9	50.0	14.0
		37	32.8	9.1	39.1	11.7	45.3	14.1	46.0	14.2	46.6	14.2	47.9	14.4	49.2	14.5
		39	32.8	9.6	39.1	12.4	44.6	14.6	45.2	14.7	45.9	14.7	47.2	14.9	48.5	15.1
110	440 (49.50)	10	30.1	4.52	35.9	5.45	41.7	6.43	44.6	6.93	47.4	7.4	53.2	8.4	58.0	8.9
		12	30.1	4.59	35.9	5.55	41.7	6.54	44.6	7.05	47.4	7.6	53.2	8.6	57.3	8.8
		14	30.1	4.67	35.9	5.65	41.7	6.66	44.6	7.18	47.4	7.7	53.2	8.8	56.5	8.8
		16	30.1	4.76	35.9	5.75	41.7	6.79	44.6	7.3	47.4	7.8	53.2	9.1	55.8	9.3
		18	30.1	4.84	35.9	5.86	41.7	6.92	44.6	7.5	47.4	8.2	53.2	9.7	55.1	9.8
		20	30.1	4.93	35.9	5.97	41.7	7.3	44.6	8.1	47.4	8.8	53.1	10.2	54.3	10.3
		21	30.1	4.98	35.9	6.15	41.7	7.6	44.6	8.4	47.4	9.2	52.8	10.4	54.0	10.5
		23	30.1	5.21	35.9	6.58	41.7	8.1	44.6	9.0	47.4	9.8	52.0	10.9	53.2	11.0
		25	30.1	5.56	35.9	7.03	41.7	8.7	44.6	9.6	47.4	10.5	51.3	11.4	52.5	11.5
		27	30.1	5.92	35.9	7.5	41.7	9.3	44.6	10.2	47.4	11.3	50.6	11.8	51.8	12.0
		29	30.1	6.31	35.9	8.0	41.7	9.9	44.6	10.9	47.4	12.0	49.8	12.3	51.0	12.4
		31	30.1	6.71	35.9	8.5	41.7	10.6	44.6	11.7	47.4	12.7	49.1	12.8	50.3	12.9
		33	30.1	7.13	35.9	9.1	41.7	11.3	44.6	12.5	47.2	13.2	48.4	13.3	49.6	13.4
		35	30.1	7.6	35.9	9.7	41.7	12.0	44.6	13.3	46.4	13.7	47.6	13.8	48.9	13.9
		37	30.1	8.1	35.9	10.3	41.7	12.8	44.6	14.1	45.7	14.1	46.9	14.3	48.1	14.4
		39	30.1	8.6	35.9	10.9	41.7	13.6	44.4	14.6	45.0	14.6	46.2	14.8	47.4	14.9
100	400 (45.00)	10	27.3	4.10	32.6	4.92	37.9	5.79	40.5	6.23	43.1	6.68	48.4	7.6	53.7	8.5
		12	27.3	4.16	32.6	5.01	37.9	5.89	40.5	6.34	43.1	6.80	48.4	7.7	53.7	8.7
		14	27.3	4.23	32.6	5.09	37.9	6.00	40.5	6.46	43.1	6.93	48.4	7.9	53.7	8.8
		16	27.3	4.31	32.6	5.19	37.9	6.11	40.5	6.58	43.1	7.06	48.4	8.0	53.7	9.2
		18	27.3	4.38	32.6	5.28	37.9	6.22	40.5	6.71	43.1	7.19	48.4	8.5	53.7	9.7
		20	27.3	4.46	32.6	5.38	37.9	6.41	40.5	7.04	43.1	7.7	48.4	9.1	53.2	10.2
		21	27.3	4.50	32.6	5.43	37.9	6.63	40.5	7.3	43.1	8.0	48.4	9.4	52.9	10.4
		23	27.3	4.62	32.6	5.79	37.9	7.10	40.5	7.8	43.1	8.5	48.4	10.1	52.1	10.9
		25	27.3	4.92	32.6	6.18	37.9	7.6	40.5	8.3	43.1	9.1	48.4	10.8	51.4	11.4
		27	27.3	5.24	32.6	6.59	37.9	8.1	40.5	8.9	43.1	9.8	48.4	11.6	50.7	11.9
		29	27.3	5.58	32.6	7.02	37.9	8.6	40.5	9.5	43.1	10.4	48.4	12.2	49.9	12.3
		31	27.3	5.93	32.6	7.5	37.9	9.2	40.5	10.2	43.1	11.1	48.1	12.7	49.2	12.8
		33	27.3	6.30	32.6	8.0	37.9	9.8	40.5	10.8	43.1	11.9	47.4	13.2	48.5	13.3
		35	27.3	6.69	32.6	8.5	37.9	10.5	40.5	11.5	43.1	12.7	46.6	13.7	47.7	13.8
		37	27.3	7.10	32.6	9.0	37.9	11.1	40.5	12.3	43.1	13.5	45.9	14.2	47.0	14.3
		39	27.3	7.5	32.6	9.6	37.9	11.8	40.5	13.1	43.1	14.4	45.2	14.7	46.3	14.8

4TW33912-3A(3)

4 Capacity tables

4 - 1 Cooling Capacity Tables

RXYRQ16P - Correction factor for mixed connection: 0.9

TC: Total Capacity: kW ; PI: Power Input: kW (compressor + outdoor fan motor)

Combination (%)	Capacity index (kW)	Outdoor air temp. °CDB	Indoor air temperature:													
			14.0 °CWB		16.0 °CWB		18.0 °CWB		19.0 °CWB		20.0 °CWB		22.0 °CWB		24.0 °CWB	
			20.0 °CDB		23.0 °CDB		16.0 °CDB		27.0 °CDB		28.0 °CDB		30.0 °CDB		32.0 °CDB	
			TC	PI	TC	PI	TC	PI	TC	PI	TC	PI	TC	PI	TC	PI
90	360 (40.50)	10	24.6	3.69	29.3	4.40	34.1	5.16	36.5	5.55	38.8	5.95	43.6	6.76	48.3	7.6
		12	24.6	3.75	29.3	4.48	34.1	5.25	36.5	5.65	38.8	6.05	43.6	6.88	48.3	7.7
		14	24.6	3.81	29.3	4.56	34.1	5.34	36.5	5.75	38.8	6.16	43.6	7.00	48.3	7.9
		16	24.6	3.87	29.3	4.64	34.1	5.44	36.5	5.86	38.8	6.28	43.6	7.14	48.3	8.0
		18	24.6	3.94	29.3	4.72	34.1	5.54	36.5	5.97	38.8	6.40	43.6	7.3	48.3	8.5
		20	24.6	4.01	29.3	4.81	34.1	5.65	36.5	6.08	38.8	6.63	43.6	7.8	48.3	9.1
		21	24.6	4.04	29.3	4.85	34.1	5.74	36.5	6.29	38.8	6.86	43.6	8.1	48.3	9.4
		23	24.6	4.11	29.3	5.05	34.1	6.14	36.5	6.73	38.8	7.3	43.6	8.7	48.3	10.1
		25	24.6	4.33	29.3	5.38	34.1	6.56	36.5	7.19	38.8	7.9	43.6	9.3	48.3	10.8
		27	24.6	4.60	29.3	5.74	34.1	7.00	36.5	7.7	38.8	8.4	43.6	9.9	48.3	11.6
		29	24.6	4.89	29.3	6.11	34.1	7.5	36.5	8.2	38.8	9.0	43.6	10.6	48.3	12.2
		31	24.6	5.20	29.3	6.50	34.1	7.9	36.5	8.7	38.8	9.5	43.6	11.3	48.1	12.7
		33	24.6	5.52	29.3	6.91	34.1	8.5	36.5	9.3	38.8	10.2	43.6	12.1	47.4	13.2
		35	24.6	5.85	29.3	7.3	34.1	9.0	36.5	9.9	38.8	10.8	43.6	12.9	46.6	13.7
		37	24.6	6.20	29.3	7.8	34.1	9.6	36.5	10.5	38.8	11.5	43.6	13.7	45.9	14.2
		39	24.6	6.57	29.3	8.3	34.1	10.2	36.5	11.2	38.8	12.3	43.6	14.5	45.2	14.6
		80	320 (36.00)	10	21.9	3.29	26.1	3.91	30.3	4.55	32.4	4.89	34.5	5.23	38.7	5.93
12	21.9			3.34	26.1	3.97	30.3	4.63	32.4	4.97	34.5	5.32	38.7	6.04	42.9	6.77
14	21.9			3.40	26.1	4.04	30.3	4.71	32.4	5.06	34.5	5.42	38.7	6.15	42.9	6.89
16	21.9			3.45	26.1	4.11	30.3	4.80	32.4	5.15	34.5	5.52	38.7	6.26	42.9	7.02
18	21.9			3.51	26.1	4.18	30.3	4.88	32.4	5.25	34.5	5.62	38.7	6.38	42.9	7.16
20	21.9			3.57	26.1	4.25	30.3	4.97	32.4	5.35	34.5	5.73	38.7	6.61	42.9	7.6
21	21.9			3.60	26.1	4.29	30.3	5.02	32.4	5.40	34.5	5.84	38.7	6.84	42.9	7.9
23	21.9			3.66	26.1	4.37	30.3	5.26	32.4	5.74	34.5	6.25	38.7	7.3	42.9	8.5
25	21.9			3.77	26.1	4.65	30.3	5.61	32.4	6.13	34.5	6.67	38.7	7.8	42.9	9.1
27	21.9			4.01	26.1	4.94	30.3	5.98	32.4	6.54	34.5	7.12	38.7	8.4	42.9	9.7
29	21.9			4.26	26.1	5.26	30.3	6.37	32.4	6.97	34.5	7.6	38.7	8.9	42.9	10.4
31	21.9			4.52	26.1	5.59	30.3	6.78	32.4	7.4	34.5	8.1	38.7	9.5	42.9	11.1
33	21.9			4.79	26.1	5.93	30.3	7.21	32.4	7.9	34.5	8.6	38.7	10.1	42.9	11.8
35	21.9			5.07	26.1	6.30	30.3	7.7	32.4	8.4	34.5	9.2	38.7	10.8	42.9	12.6
37	21.9			5.37	26.1	6.68	30.3	8.1	32.4	8.9	34.5	9.7	38.7	11.5	42.9	13.4
39	21.9			5.68	26.1	7.08	30.3	8.6	32.4	9.5	34.5	10.4	38.7	12.2	42.9	14.3

4TW33912-3A(4)

NOTES - ANMERKUNGEN - Σημειώσεις - NOTAS - REMARQUES - NOTE - OPMERKINGEN - Примечания - NOTLAR

- The above table shows the average value of conditions which may occur.
Die obige Tabelle zeigt den Durchschnittswert der Bedingungen, die auftreten können.
Στον παραπάνω πίνακα αναγράφεται η μέση τιμή για συνθήκες που μπορεί να προκύψουν.
La tabla de arriba muestra el valor medio de condiciones que pueden ocurrir.
Le tableau ci-dessus donne la valeur moyenne pour des conditions qui peuvent survenir.
La tabella in alto mostra il valore delle condizioni medie che si possono riscontrare.
De tabel hierboven geeft de gemiddelde waarde aan van situaties die kunnen voorvallen.
Таблица расположенная выше показывает среднее значение условий, которые могут наступить.
Yukarıdaki tablo meydana gelebilecek koşulların ortalama değerini göstermektedir.
- Correction factor for mixed connection: 0.9. For more information refer to the selection procedure.
Korrekturfaktoren für gemischten Anschluss: 0,9. Weitere Informationen finden Sie im Auswahlverfahren.
Συντελεστής διόρθωσης για συνδυαζόμενη σύνδεση: 0,9. Για περισσότερες πληροφορίες ανατρέξτε στη διαδικασία επιλογής.
Factor de corrección para conexión combinada: 0,9. Si desea más información, consulte el procedimiento de selección.
Facteur de correction pour connexion d'unités mixtes : 0,9. Pour plus d'informations, se reporter à la procédure de sélection.
Fattore di correzione per collegamento varie unità: 0,9. Per maggiori informazioni fare riferimento alla procedura di selezione.
Correctiefactor voor gemengde aansluiting: 0,9. Zie selectieprocedure voor meer informatie.
Поправочный коэффициент для комбинированного соединения: 0,9. Подробная информация приводится в разделе порядка выбора.
Karışık bağlantı için düzeltme faktörü: 0.9. Daha fazla bilgi için, seçim prosedürüne bakın.

4 Capacity tables

4 - 1 Cooling Capacity Tables

RXYRQ16P - Correction factor for mixed connection: 0.8																
TC: Total Capacity: kW ; PI: Power Input: kW (compressor + outdoor fan motor)																
Combination (%)	Capacity index (kW)	Outdoor air temp. °CDB	Indoor air temperature:													
			14.0 °CWB		16.0 °CWB		18.0 °CWB		19.0 °CWB		20.0 °CWB		22.0 °CWB		24.0 °CWB	
			20.0 °CDB		23.0 °CDB		16.0 °CDB		27.0 °CDB		28.0 °CDB		30.0 °CDB		32.0 °CDB	
			TC	PI	TC	PI	TC	PI	TC	PI	TC	PI	TC	PI	TC	PI
130	520 (58.50)	10	31.6	4.64	37.7	5.58	43.8	6.5	46.8	7.0	49.8	7.5	55.9	8.5	60.2	8.28
		12	31.6	4.72	37.7	5.67	43.8	6.6	46.8	7.1	49.8	7.6	55.9	8.6	59.5	8.5
		14	31.6	4.80	37.7	5.77	43.8	6.8	46.8	7.3	49.8	7.8	55.9	8.9	58.8	9.0
		16	31.6	4.88	37.7	5.87	43.8	6.9	46.8	7.5	49.8	8.2	55.9	9.4	58.0	9.4
		18	31.6	4.97	37.7	5.98	43.8	7.3	46.8	8.1	49.8	8.9	55.9	9.8	57.3	9.9
		20	31.6	5.06	37.7	6.4	43.8	7.9	46.8	8.7	49.8	9.5	55.2	10.3	56.6	10.4
		21	31.6	5.20	37.7	6.6	43.8	8.1	46.8	9.0	49.8	9.9	54.8	10.6	56.2	10.7
		23	31.6	5.55	37.7	7.0	43.8	8.7	46.8	9.6	49.8	10.6	54.1	11.0	55.5	11.2
		25	31.6	5.93	37.7	7.5	43.8	9.3	46.8	10.3	49.8	11.3	53.3	11.5	54.7	11.7
		27	31.6	6.3	37.7	8.0	43.8	10.0	46.8	11.0	49.8	11.9	52.6	12.0	54.0	12.1
		29	31.6	6.7	37.7	8.6	43.8	10.7	46.8	11.8	49.8	12.4	51.9	12.5	53.3	12.6
		31	31.6	7.2	37.7	9.1	43.8	11.4	46.8	12.6	49.7	12.9	51.1	13.0	52.5	13.1
33	31.6	7.6	37.7	9.7	43.8	12.1	46.8	13.3	49.0	13.4	50.4	13.5	51.8	13.7		
35	31.6	8.1	37.7	10.4	43.8	12.9	46.8	13.8	48.2	13.9	49.7	14.0	51.1	14.2		
37	31.6	8.6	37.7	11.0	43.8	13.8	46.8	14.3	47.5	14.3	48.9	14.5	50.4	14.7		
39	31.6	9.2	37.7	11.8	43.8	14.7	46.8	14.8	46.8	14.8	48.2	15.0	49.6	15.2		
120	480 (54.00)	10	29.2	4.28	34.8	5.13	40.4	6.00	43.2	6.4	46.0	6.9	51.6	7.8	57.2	8.6
		12	29.2	4.35	34.8	5.21	40.4	6.11	43.2	6.6	46.0	7.0	51.6	7.9	57.2	8.5
		14	29.2	4.42	34.8	5.30	40.4	6.2	43.2	6.7	46.0	7.1	51.6	8.1	57.2	8.9
		16	29.2	4.50	34.8	5.40	40.4	6.3	43.2	6.8	46.0	7.3	51.6	8.7	56.9	9.4
		18	29.2	4.57	34.8	5.50	40.4	6.5	43.2	7.2	46.0	7.9	51.6	9.3	56.2	9.9
		20	29.2	4.66	34.8	5.70	40.4	7.0	43.2	7.7	46.0	8.5	51.6	10.0	55.5	10.3
		21	29.2	4.70	34.8	5.90	40.4	7.3	43.2	8.0	46.0	8.8	51.6	10.4	55.1	10.6
		23	29.2	5.01	34.8	6.3	40.4	7.8	43.2	8.6	46.0	9.4	51.6	11.0	54.4	11.1
		25	29.2	5.34	34.8	6.7	40.4	8.3	43.2	9.2	46.0	10.1	51.6	11.5	53.6	11.6
		27	29.2	5.69	34.8	7.2	40.4	8.9	43.2	9.8	46.0	10.8	51.6	11.9	52.9	12.1
		29	29.2	6.06	34.8	7.7	40.4	9.5	43.2	10.5	46.0	11.5	50.9	12.4	52.2	12.5
		31	29.2	6.4	34.8	8.2	40.4	10.1	43.2	11.2	46.0	12.3	50.1	12.9	51.4	13.0
33	29.2	6.8	34.8	8.7	40.4	10.8	43.2	11.9	46.0	13.1	49.4	13.4	50.7	13.5		
35	29.2	7.3	34.8	9.3	40.4	11.5	43.2	12.7	46.0	13.8	48.7	13.9	50.0	14.0		
37	29.2	7.7	34.8	9.8	40.4	12.2	43.2	13.5	46.0	14.2	47.9	14.4	49.2	14.5		
39	29.2	8.2	34.8	10.5	40.4	13.0	43.2	14.4	45.9	14.7	47.2	14.9	48.5	15.1		
110	440 (49.50)	10	26.7	3.92	31.9	4.68	37.0	5.48	39.6	5.88	42.2	6.3	47.3	7.1	52.5	7.9
		12	26.7	3.99	31.9	4.76	37.0	5.57	39.6	5.98	42.2	6.4	47.3	7.2	52.5	8.1
		14	26.7	4.05	31.9	4.84	37.0	5.67	39.6	6.09	42.2	6.5	47.3	7.4	52.5	8.2
		16	26.7	4.12	31.9	4.93	37.0	5.77	39.6	6.2	42.2	6.6	47.3	7.6	52.5	8.9
		18	26.7	4.19	31.9	5.02	37.0	5.87	39.6	6.4	42.2	6.9	47.3	8.2	52.5	9.6
		20	26.7	4.26	31.9	5.11	37.0	6.2	39.6	6.8	42.2	7.5	47.3	8.8	52.5	10.3
		21	26.7	4.30	31.9	5.26	37.0	6.4	39.6	7.1	42.2	7.7	47.3	9.1	52.5	10.5
		23	26.7	4.49	31.9	5.62	37.0	6.9	39.6	7.6	42.2	8.3	47.3	9.8	52.5	11.0
		25	26.7	4.79	31.9	6.00	37.0	7.4	39.6	8.1	42.2	8.8	47.3	10.5	52.5	11.5
		27	26.7	5.10	31.9	6.4	37.0	7.8	39.6	8.6	42.2	9.5	47.3	11.2	51.8	12.0
		29	26.7	5.42	31.9	6.8	37.0	8.4	39.6	9.2	42.2	10.1	47.3	12.0	51.0	12.4
		31	26.7	5.76	31.9	7.3	37.0	8.9	39.6	9.8	42.2	10.8	47.3	12.8	50.3	12.9
33	26.7	6.12	31.9	7.7	37.0	9.5	39.6	10.5	42.2	11.5	47.3	13.3	49.6	13.4		
35	26.7	6.5	31.9	8.2	37.0	10.1	39.6	11.2	42.2	12.2	47.3	13.8	48.9	13.9		
37	26.7	6.9	31.9	8.7	37.0	10.8	39.6	11.9	42.2	13.0	46.9	14.3	48.1	14.4		
39	26.7	7.3	31.9	9.3	37.0	11.5	39.6	12.7	42.2	13.9	46.2	14.8	47.4	14.9		
100	400 (45.00)	10	24.3	3.58	29.0	4.25	33.7	4.96	36.0	5.32	38.3	5.68	43.0	6.4	47.7	7.2
		12	24.3	3.63	29.0	4.32	33.7	5.04	36.0	5.41	38.3	5.78	43.0	6.5	47.7	7.3
		14	24.3	3.69	29.0	4.39	33.7	5.13	36.0	5.50	38.3	5.88	43.0	6.6	47.7	7.4
		16	24.3	3.75	29.0	4.47	33.7	5.22	36.0	5.60	38.3	5.99	43.0	6.8	47.7	7.7
		18	24.3	3.81	29.0	4.55	33.7	5.31	36.0	5.70	38.3	6.09	43.0	7.1	47.7	8.3
		20	24.3	3.88	29.0	4.63	33.7	5.46	36.0	5.98	38.3	6.5	43.0	7.7	47.7	8.9
		21	24.3	3.91	29.0	4.67	33.7	5.65	36.0	6.2	38.3	6.7	43.0	7.9	47.7	9.2
		23	24.3	4.01	29.0	4.97	33.7	6.04	36.0	6.6	38.3	7.2	43.0	8.5	47.7	9.9
		25	24.3	4.27	29.0	5.30	33.7	6.5	36.0	7.1	38.3	7.7	43.0	9.1	47.7	10.6
		27	24.3	4.54	29.0	5.65	33.7	6.9	36.0	7.5	38.3	8.2	43.0	9.7	47.7	11.4
		29	24.3	4.82	29.0	6.01	33.7	7.3	36.0	8.0	38.3	8.8	43.0	10.4	47.7	12.1
		31	24.3	5.12	29.0	6.4	33.7	7.8	36.0	8.6	38.3	9.4	43.0	11.1	47.7	12.8
33	24.3	5.43	29.0	6.8	33.7	8.3	36.0	9.1	38.3	10.0	43.0	11.8	47.7	13.3		
35	24.3	5.76	29.0	7.2	33.7	8.8	36.0	9.7	38.3	10.6	43.0	12.6	47.7	13.8		
37	24.3	6.11	29.0	7.7	33.7	9.4	36.0	10.3	38.3	11.3	43.0	13.4	47.0	14.3		
39	24.3	6.5	29.0	8.1	33.7	10.0	36.0	11.0	38.3	12.1	43.0	14.3	46.3	14.8		

4TW33912-3A(5)

4 Capacity tables

4 - 1 Cooling Capacity Tables

RXYRQ16P - Correction factor for mixed connection: 0.8

TC: Total Capacity: kW; PI: Power Input: kW (compressor + outdoor fan motor)

Combination (%)	Capacity index (kW)	Outdoor air temp. °CDB	Indoor air temperature:													
			14.0 °CWB		16.0 °CWB		18.0 °CWB		19.0 °CWB		20.0 °CWB		22.0 °CWB		24.0 °CWB	
			TC	PI	TC	PI	TC	PI	TC	PI	TC	PI	TC	PI	TC	PI
90 (40.50)	360	10	21.9	3.24	26.1	3.83	30.3	4.45	32.4	4.76	34.5	5.09	38.7	5.74	42.9	6.4
		12	21.9	3.29	26.1	3.89	30.3	4.52	32.4	4.84	34.5	5.17	38.7	5.84	42.9	6.5
		14	21.9	3.34	26.1	3.95	30.3	4.60	32.4	4.93	34.5	5.26	38.7	5.94	42.9	6.6
		16	21.9	3.39	26.1	4.02	30.3	4.68	32.4	5.01	34.5	5.35	38.7	6.05	42.9	6.8
		18	21.9	3.45	26.1	4.09	30.3	4.76	32.4	5.10	34.5	5.45	38.7	6.2	42.9	7.1
		20	21.9	3.50	26.1	4.16	30.3	4.84	32.4	5.20	34.5	5.64	38.7	6.6	42.9	7.6
		21	21.9	3.53	26.1	4.19	30.3	4.92	32.4	5.37	34.5	5.84	38.7	6.8	42.9	7.9
		23	21.9	3.59	26.1	4.36	30.3	5.26	32.4	5.74	34.5	6.2	38.7	7.3	42.9	8.5
		25	21.9	3.77	26.1	4.65	30.3	5.61	32.4	6.13	34.5	6.7	38.7	7.8	42.9	9.1
		27	21.9	4.01	26.1	4.94	30.3	5.98	32.4	6.5	34.5	7.1	38.7	8.4	42.9	9.7
		29	21.9	4.26	26.1	5.26	30.3	6.4	32.4	7.0	34.5	7.6	38.7	8.9	42.9	10.4
		31	21.9	4.52	26.1	5.59	30.3	6.8	32.4	7.4	34.5	8.1	38.7	9.5	42.9	11.1
		33	21.9	4.79	26.1	5.93	30.3	7.2	32.4	7.9	34.5	8.6	38.7	10.1	42.9	11.8
		35	21.9	5.07	26.1	6.3	30.3	7.7	32.4	8.4	34.5	9.2	38.7	10.8	42.9	12.6
		37	21.9	5.37	26.1	6.7	30.3	8.1	32.4	8.9	34.5	9.7	38.7	11.5	42.9	13.4
		39	21.9	5.68	26.1	7.1	30.3	8.6	32.4	9.5	34.5	10.4	38.7	12.2	42.9	14.3
		80	320	10	19.4	2.92	23.2	3.42	26.9	3.95	28.8	4.22	30.7	4.50	34.4	5.07
12	19.4			2.96	23.2	3.47	26.9	4.01	28.8	4.29	30.7	4.58	34.4	5.16	38.2	5.75
14	19.4			3.00	23.2	3.53	26.9	4.08	28.8	4.37	30.7	4.66	34.4	5.25	38.2	5.85
16	19.4			3.05	23.2	3.58	26.9	4.15	28.8	4.44	30.7	4.74	34.4	5.34	38.2	5.96
18	19.4			3.09	23.2	3.64	26.9	4.22	28.8	4.52	30.7	4.82	34.4	5.44	38.2	6.06
20	19.4			3.14	23.2	3.70	26.9	4.29	28.8	4.60	30.7	4.91	34.4	5.63	38.2	6.5
21	19.4			3.17	23.2	3.74	26.9	4.33	28.8	4.64	30.7	5.00	34.4	5.82	38.2	6.7
23	19.4			3.22	23.2	3.80	26.9	4.53	28.8	4.93	30.7	5.34	34.4	6.2	38.2	7.2
25	19.4			3.32	23.2	4.04	26.9	4.83	28.8	5.26	30.7	5.70	34.4	6.6	38.2	7.7
27	19.4			3.52	23.2	4.29	26.9	5.14	28.8	5.60	30.7	6.08	34.4	7.1	38.2	8.2
29	19.4			3.73	23.2	4.56	26.9	5.47	28.8	5.96	30.7	6.5	34.4	7.6	38.2	8.7
31	19.4			3.95	23.2	4.84	26.9	5.82	28.8	6.3	30.7	6.9	34.4	8.1	38.2	9.3
33	19.4			4.19	23.2	5.13	26.9	6.18	28.8	6.7	30.7	7.3	34.4	8.6	38.2	9.9
35	19.4			4.43	23.2	5.44	26.9	6.6	28.8	7.2	30.7	7.8	34.4	9.1	38.2	10.6
37	19.4			4.68	23.2	5.76	26.9	7.0	28.8	7.6	30.7	8.3	34.4	9.7	38.2	11.3
39	19.4			4.95	23.2	6.10	26.9	7.4	28.8	8.1	30.7	8.8	34.4	10.3	38.2	12.0

4TW33912-3A(6)

NOTES - ANMERKUNGEN - Σημειώσεις - NOTAS - REMARQUES - NOTE - OPMERKINGEN - Примечания - NOTLAR

- The above table shows the average value of conditions which may occur.
Die obige Tabelle zeigt den Durchschnittswert der Bedingungen, die auftreten können.
 Στον παραπάνω πίνακα αναγράφεται η μέση τιμή για συνθήκες που μπορεί να προκύψουν.
La tabla de arriba muestra el valor medio de condiciones que pueden ocurrir.
 Le tableau ci-dessus donne la valeur moyenne pour des conditions qui peuvent survenir.
La tabella in alto mostra il valore delle condizioni medie che si possono riscontrare.
 De tabel hierboven geeft de gemiddelde waarde aan van situaties die kunnen voorvallen.
Таблица расположенная выше показывает среднее значение условий, которые могут наступить.
 Yukarıdaki tablo meydana gelebilecek koşulların ortalama değerini göstermektedir.
- Correction factor for mixed connection: 0.8. For more information refer to the selection procedure.
Korrekturfaktoren für gemischten Anschluss: 0,8. Weitere Informationen finden Sie im Auswahlverfahren.
 Συντελεστής διόρθωσης για συνδυαζόμενη σύνδεση: 0,8. Για περισσότερες πληροφορίες ανατρέξτε στη διαδικασία επιλογής.
Factor de corrección para conexión combinada: 0,8. Si desea más información, consulte el procedimiento de selección.
 Facteur de correction pour connexion d'unités mixtes : 0,8. Pour plus d'informations, se reporter à la procédure de sélection.
Fattore di correzione per collegamento varie unità: 0,8. Per maggiori informazioni fare riferimento alla procedura di selezione.
 Correctiefactor voor gemengde aansluiting: 0,8. Zie selectieprocedure voor meer informatie.
Поправочный коэффициент для комбинированного соединения: 0,8. Подробная информация приводится в разделе порядка выбора.
 Karışık bağlantı için düzeltme faktörü: 0.8. Daha fazla bilgi için, seçim prosedürüne bakın.

4 Capacity tables

4 - 1 Cooling Capacity Tables

RXYRQ16P - Correction factor for mixed connection: 0.7																		
TC: Total Capacity: kW ; PI: Power Input: kW (compressor + outdoor fan motor)																		
Combination (%)	Capacity index (kW)	Outdoor air temp. °CDB	Indoor air temperature:															
			14.0 °CWB		16.0 °CWB		18.0 °CWB		19.0 °CWB		20.0 °CWB		22.0 °CWB		24.0 °CWB			
			20.0 °CDB		23.0 °CDB		16.0 °CDB		27.0 °CDB		28.0 °CDB		30.0 °CDB		32.0 °CDB			
			TC	PI	TC	PI	TC	PI	TC	PI	TC	PI	TC	PI	TC	PI		
130	520 (58.50)	10	27.6	3.94	33.0	4.68	38.3	5.4	41.0	5.8	43.6	6.2	48.9	6.9	54.3	7.65		
		12	27.6	4.00	33.0	4.76	38.3	5.5	41.0	5.9	43.6	6.3	48.9	7.0	54.3	8.0		
		14	27.6	4.07	33.0	4.84	38.3	5.6	41.0	6.0	43.6	6.4	48.9	7.4	54.3	8.7		
		16	27.6	4.13	33.0	4.92	38.3	5.7	41.0	6.2	43.6	6.8	48.9	8.0	54.3	9.4		
		18	27.6	4.20	33.0	5.00	38.3	6.1	41.0	6.7	43.6	7.3	48.9	8.6	54.3	9.9		
		20	27.6	4.27	33.0	5.3	38.3	6.5	41.0	7.1	43.6	7.8	48.9	9.3	54.3	10.4		
		21	27.6	4.39	33.0	5.5	38.3	6.7	41.0	7.4	43.6	8.1	48.9	9.6	54.3	10.7		
		23	27.6	4.68	33.0	5.9	38.3	7.2	41.0	7.9	43.6	8.7	48.9	10.3	54.3	11.2		
		25	27.6	4.99	33.0	6.3	38.3	7.7	41.0	8.5	43.6	9.3	48.9	11.0	54.3	11.7		
		27	27.6	5.3	33.0	6.7	38.3	8.2	41.0	9.1	43.6	9.9	48.9	11.8	54.0	12.1		
		29	27.6	5.7	33.0	7.1	38.3	8.8	41.0	9.7	43.6	10.6	48.9	12.5	53.3	12.6		
		31	27.6	6.0	33.0	7.6	38.3	9.4	41.0	10.3	43.6	11.3	48.9	13.0	52.5	13.1		
		33	27.6	6.4	33.0	8.1	38.3	10.0	41.0	11.0	43.6	12.1	48.9	13.5	51.8	13.7		
		35	27.6	6.8	33.0	8.6	38.3	10.6	41.0	11.7	43.6	12.9	48.9	14.0	51.1	14.2		
		37	27.6	7.2	33.0	9.1	38.3	11.3	41.0	12.5	43.6	13.7	48.9	14.5	50.4	14.7		
		39	27.6	7.6	33.0	9.7	38.3	12.0	41.0	13.3	43.6	14.6	48.2	15.0	49.6	15.2		
		120	480 (54.00)	10	25.5	3.65	30.4	4.33	35.3	5.02	37.8	5.4	40.3	5.7	45.2	6.4	50.1	7.1
				12	25.5	3.71	30.4	4.40	35.3	5.10	37.8	5.5	40.3	5.8	45.2	6.5	50.1	7.2
14	25.5			3.77	30.4	4.47	35.3	5.2	37.8	5.5	40.3	5.9	45.2	6.6	50.1	7.7		
16	25.5			3.83	30.4	4.54	35.3	5.3	37.8	5.6	40.3	6.0	45.2	7.1	50.1	8.3		
18	25.5			3.89	30.4	4.62	35.3	5.4	37.8	6.0	40.3	6.5	45.2	7.7	50.1	8.9		
20	25.5			3.95	30.4	4.79	35.3	5.8	37.8	6.4	40.3	7.0	45.2	8.2	50.1	9.6		
21	25.5			3.99	30.4	4.95	35.3	6.0	37.8	6.6	40.3	7.2	45.2	8.5	50.1	9.9		
23	25.5			4.25	30.4	5.3	35.3	6.5	37.8	7.1	40.3	7.7	45.2	9.1	50.1	10.7		
25	25.5			4.52	30.4	5.6	35.3	6.9	37.8	7.6	40.3	8.3	45.2	9.8	50.1	11.4		
27	25.5			4.81	30.4	6.0	35.3	7.4	37.8	8.1	40.3	8.8	45.2	10.5	50.1	12.1		
29	25.5			5.12	30.4	6.4	35.3	7.8	37.8	8.6	40.3	9.4	45.2	11.2	50.1	12.5		
31	25.5			5.4	30.4	6.8	35.3	8.4	37.8	9.2	40.3	10.1	45.2	11.9	50.1	13.0		
33	25.5			5.8	30.4	7.2	35.3	8.9	37.8	9.8	40.3	10.7	45.2	12.7	50.1	13.5		
35	25.5			6.1	30.4	7.7	35.3	9.5	37.8	10.4	40.3	11.4	45.2	13.6	50.0	14.0		
37	25.5			6.5	30.4	8.2	35.3	10.1	37.8	11.1	40.3	12.2	45.2	14.4	49.2	14.5		
39	25.5			6.9	30.4	8.7	35.3	10.7	37.8	11.8	40.3	13.0	45.2	14.9	48.5	15.1		
110	440 (49.50)			10	23.4	3.37	27.9	3.98	32.4	4.60	34.7	4.92	36.9	5.2	41.4	5.9	45.9	6.5
				12	23.4	3.42	27.9	4.04	32.4	4.68	34.7	5.00	36.9	5.3	41.4	6.0	45.9	6.6
		14	23.4	3.47	27.9	4.10	32.4	4.75	34.7	5.08	36.9	5.4	41.4	6.1	45.9	6.8		
		16	23.4	3.53	27.9	4.17	32.4	4.83	34.7	5.2	36.9	5.5	41.4	6.3	45.9	7.3		
		18	23.4	3.58	27.9	4.24	32.4	4.91	34.7	5.3	36.9	5.8	41.4	6.8	45.9	7.8		
		20	23.4	3.64	27.9	4.31	32.4	5.2	34.7	5.7	36.9	6.2	41.4	7.3	45.9	8.4		
		21	23.4	3.67	27.9	4.44	32.4	5.4	34.7	5.9	36.9	6.4	41.4	7.5	45.9	8.7		
		23	23.4	3.83	27.9	4.74	32.4	5.7	34.7	6.3	36.9	6.8	41.4	8.1	45.9	9.4		
		25	23.4	4.08	27.9	5.05	32.4	6.1	34.7	6.7	36.9	7.3	41.4	8.6	45.9	10.0		
		27	23.4	4.34	27.9	5.4	32.4	6.5	34.7	7.2	36.9	7.8	41.4	9.2	45.9	10.7		
		29	23.4	4.61	27.9	5.7	32.4	7.0	34.7	7.6	36.9	8.3	41.4	9.8	45.9	11.5		
		31	23.4	4.89	27.9	6.1	32.4	7.4	34.7	8.1	36.9	8.9	41.4	10.5	45.9	12.2		
		33	23.4	5.19	27.9	6.5	32.4	7.9	34.7	8.7	36.9	9.5	41.4	11.2	45.9	13.1		
		35	23.4	5.5	27.9	6.9	32.4	8.4	34.7	9.2	36.9	10.1	41.4	11.9	45.9	13.9		
		37	23.4	5.8	27.9	7.3	32.4	8.9	34.7	9.8	36.9	10.7	41.4	12.7	45.9	14.4		
		39	23.4	6.2	27.9	7.7	32.4	9.5	34.7	10.4	36.9	11.4	41.4	13.5	45.9	14.9		
		100	400 (45.00)	10	21.3	3.09	25.4	3.63	29.5	4.19	31.5	4.48	33.5	4.76	37.6	5.3	41.7	5.9
				12	21.3	3.14	25.4	3.69	29.5	4.26	31.5	4.55	33.5	4.84	37.6	5.4	41.7	6.0
14	21.3			3.19	25.4	3.75	29.5	4.33	31.5	4.62	33.5	4.92	37.6	5.5	41.7	6.1		
16	21.3			3.23	25.4	3.81	29.5	4.40	31.5	4.70	33.5	5.00	37.6	5.6	41.7	6.4		
18	21.3			3.28	25.4	3.87	29.5	4.47	31.5	4.78	33.5	5.09	37.6	5.9	41.7	6.8		
20	21.3			3.33	25.4	3.93	29.5	4.59	31.5	5.01	33.5	5.4	37.6	6.4	41.7	7.3		
21	21.3			3.36	25.4	3.96	29.5	4.75	31.5	5.2	33.5	5.6	37.6	6.6	41.7	7.6		
23	21.3			3.44	25.4	4.21	29.5	5.07	31.5	5.5	33.5	6.0	37.6	7.0	41.7	8.1		
25	21.3			3.66	25.4	4.49	29.5	5.4	31.5	5.9	33.5	6.4	37.6	7.5	41.7	8.7		
27	21.3			3.89	25.4	4.78	29.5	5.8	31.5	6.3	33.5	6.9	37.6	8.0	41.7	9.3		
29	21.3			4.12	25.4	5.08	29.5	6.1	31.5	6.7	33.5	7.3	37.6	8.6	41.7	9.9		
31	21.3			4.37	25.4	5.4	29.5	6.5	31.5	7.1	33.5	7.8	37.6	9.1	41.7	10.6		
33	21.3			4.63	25.4	5.7	29.5	6.9	31.5	7.6	33.5	8.3	37.6	9.7	41.7	11.3		
35	21.3			4.91	25.4	6.1	29.5	7.4	31.5	8.1	33.5	8.8	37.6	10.4	41.7	12.1		
37	21.3			5.19	25.4	6.4	29.5	7.8	31.5	8.6	33.5	9.4	37.6	11.0	41.7	12.8		
39	21.3			5.5	25.4	6.8	29.5	8.3	31.5	9.1	33.5	10.0	37.6	11.7	41.7	13.7		

4TW33912-3A(7)

4 Capacity tables

4 - 1 Cooling Capacity Tables

RXYRQ16P - Correction factor for mixed connection: 0.7

TC: Total Capacity: kW ; PI: Power Input: kW (compressor + outdoor fan motor)

Combination (%)	Capacity index (kW)	Outdoor air temp. °CDB	Indoor air temperature:													
			14.0 °CWB		16.0 °CWB		18.0 °CWB		19.0 °CWB		20.0 °CWB		22.0 °CWB		24.0 °CWB	
			TC	PI	TC	PI	TC	PI	TC	PI	TC	PI	TC	PI	TC	PI
90	360 (40.50)	10	19.1	2.83	22.8	3.30	26.5	3.79	28.4	4.04	30.2	4.29	33.9	4.81	37.6	5.3
		12	19.1	2.86	22.8	3.35	26.5	3.85	28.4	4.10	30.2	4.36	33.9	4.89	37.6	5.4
		14	19.1	2.91	22.8	3.40	26.5	3.91	28.4	4.17	30.2	4.43	33.9	4.97	37.6	5.5
		16	19.1	2.95	22.8	3.45	26.5	3.97	28.4	4.24	30.2	4.51	33.9	5.05	37.6	5.6
		18	19.1	2.99	22.8	3.50	26.5	4.04	28.4	4.31	30.2	4.58	33.9	5.1	37.6	5.9
		20	19.1	3.04	22.8	3.56	26.5	4.10	28.4	4.38	30.2	4.74	33.9	5.5	37.6	6.3
		21	19.1	3.06	22.8	3.59	26.5	4.17	28.4	4.53	30.2	4.90	33.9	5.7	37.6	6.6
		23	19.1	3.11	22.8	3.72	26.5	4.45	28.4	4.83	30.2	5.2	33.9	6.1	37.6	7.0
		25	19.1	3.26	22.8	3.96	26.5	4.74	28.4	5.15	30.2	5.6	33.9	6.5	37.6	7.5
		27	19.1	3.46	22.8	4.21	26.5	5.04	28.4	5.5	30.2	6.0	33.9	6.9	37.6	8.0
		29	19.1	3.67	22.8	4.47	26.5	5.4	28.4	5.8	30.2	6.3	33.9	7.4	37.6	8.5
		31	19.1	3.89	22.8	4.75	26.5	5.7	28.4	6.2	30.2	6.7	33.9	7.9	37.6	9.1
		33	19.1	4.11	22.8	5.04	26.5	6.1	28.4	6.6	30.2	7.2	33.9	8.4	37.6	9.7
		35	19.1	4.35	22.8	5.3	26.5	6.4	28.4	7.0	30.2	7.6	33.9	8.9	37.6	10.3
		37	19.1	4.60	22.8	5.7	26.5	6.8	28.4	7.4	30.2	8.1	33.9	9.5	37.6	11.0
		39	19.1	4.86	22.8	6.0	26.5	7.2	28.4	7.9	30.2	8.6	33.9	10.1	37.6	11.7
		80	320 (36.00)	10	17.0	2.57	20.3	2.97	23.6	3.39	25.2	3.61	26.8	3.83	30.1	4.28
12	17.0			2.60	20.3	3.01	23.6	3.44	25.2	3.67	26.8	3.89	30.1	4.35	33.4	4.82
14	17.0			2.63	20.3	3.06	23.6	3.50	25.2	3.72	26.8	3.95	30.1	4.42	33.4	4.90
16	17.0			2.67	20.3	3.10	23.6	3.55	25.2	3.78	26.8	4.02	30.1	4.50	33.4	4.98
18	17.0			2.71	20.3	3.15	23.6	3.61	25.2	3.84	26.8	4.08	30.1	4.57	33.4	5.07
20	17.0			2.75	20.3	3.20	23.6	3.67	25.2	3.91	26.8	4.15	30.1	4.72	33.4	5.4
21	17.0			2.77	20.3	3.22	23.6	3.70	25.2	3.94	26.8	4.23	30.1	4.89	33.4	5.6
23	17.0			2.81	20.3	3.27	23.6	3.86	25.2	4.18	26.8	4.52	30.1	5.2	33.4	6.0
25	17.0			2.89	20.3	3.47	23.6	4.11	25.2	4.46	26.8	4.81	30.1	5.6	33.4	6.4
27	17.0			3.06	20.3	3.69	23.6	4.37	25.2	4.74	26.8	5.12	30.1	5.9	33.4	6.8
29	17.0			3.24	20.3	3.91	23.6	4.65	25.2	5.04	26.8	5.4	30.1	6.3	33.4	7.3
31	17.0			3.43	20.3	4.15	23.6	4.93	25.2	5.4	26.8	5.8	30.1	6.7	33.4	7.7
33	17.0			3.63	20.3	4.39	23.6	5.23	25.2	5.7	26.8	6.2	30.1	7.1	33.4	8.2
35	17.0			3.83	20.3	4.65	23.6	5.5	25.2	6.0	26.8	6.5	30.1	7.6	33.4	8.7
37	17.0			4.05	20.3	4.92	23.6	5.9	25.2	6.4	26.8	6.9	30.1	8.1	33.4	9.3
39	17.0			4.27	20.3	5.20	23.6	6.2	25.2	6.8	26.8	7.4	30.1	8.6	33.4	9.9

4TW33912-3A(8)

NOTES - ANMERKUNGEN - Σημειώσεις - NOTAS - REMARQUES - NOTE - OPMERKINGEN - Примечания - NOTLAR

- The above table shows the average value of conditions which may occur.
Die obige Tabelle zeigt den Durchschnittswert der Bedingungen, die auftreten können.
 Στον παραπάνω πίνακα αναγράφεται η μέση τιμή για συνθήκες που μπορεί να προκύψουν.
La tabla de arriba muestra el valor medio de condiciones que pueden ocurrir.
 Le tableau ci-dessus donne la valeur moyenne pour des conditions qui peuvent survenir.
La tabella in alto mostra il valore delle condizioni medie che si possono riscontrare.
 De tabel hierboven geeft de gemiddelde waarde aan van situaties die kunnen voorvallen.
Таблица расположенная выше показывает среднее значение условий, которые могут наступить.
 Yukarıdaki tablo meydana gelebilecek koşulların ortalama değerini göstermektedir.
- Correction factor for mixed connection: 0.7. For more information refer to the selection procedure.
Korrekturfaktoren für gemischten Anschluss: 0,7. Weitere Informationen finden Sie im Auswahlverfahren.
 Συντελεστής διόρθωσης για συνδυαζόμενη σύνδεση: 0,7. Για περισσότερες πληροφορίες ανατρέξτε στη διαδικασία επιλογής.
Factor de corrección para conexión combinada: 0,7. Si desea más información, consulte el procedimiento de selección.
 Facteur de correction pour connexion d'unités mixtes : 0,7. Pour plus d'informations, se reporter à la procédure de sélection.
Fattore di correzione per collegamento varie unità: 0,7. Per maggiori informazioni fare riferimento alla procedura di selezione.
 Correctiefactor voor gemengde aansluiting: 0,7. Zie selectieprocedure voor meer informatie.
Поправочный коэффициент для комбинированного соединения: 0,7. Подробная информация приводится в разделе порядка выбора.
 Karışık bağlantı için düzeltme faktörü: 0.7. Daha fazla bilgi için, seçim prosedürüne bakın.

4 Capacity tables

4 - 1 Cooling Capacity Tables

RXYRQ16P - Correction factor for mixed connection: 0.6																		
TC: Total Capacity: kW ; PI: Power Input: kW (compressor + outdoor fan motor)																		
Combination (%)	Capacity index (kW)	Outdoor air temp. °CDB	Indoor air temperature:															
			14.0 °CWB		16.0 °CWB		18.0 °CWB		19.0 °CWB		20.0 °CWB		22.0 °CWB		24.0 °CWB			
			20.0 °CDB		23.0 °CDB		16.0 °CDB		27.0 °CDB		28.0 °CDB		30.0 °CDB		32.0 °CDB			
			TC	PI	TC	PI	TC	PI	TC	PI	TC	PI	TC	PI	TC	PI		
130	520 (58.50)	10	23.7	3.30	28.3	3.87	32.8	4.4	35.1	4.7	37.4	5.0	41.9	5.6	46.5	6.10		
		12	23.7	3.35	28.3	3.93	32.8	4.5	35.1	4.8	37.4	5.1	41.9	5.6	46.5	6.4		
		14	23.7	3.40	28.3	3.99	32.8	4.6	35.1	4.9	37.4	5.2	41.9	5.9	46.5	6.9		
		16	23.7	3.45	28.3	4.05	32.8	4.6	35.1	5.0	37.4	5.5	41.9	6.4	46.5	7.4		
		18	23.7	3.50	28.3	4.11	32.8	4.9	35.1	5.4	37.4	5.9	41.9	6.9	46.5	8.0		
		20	23.7	3.56	28.3	4.4	32.8	5.3	35.1	5.8	37.4	6.3	41.9	7.4	46.5	8.6		
		21	23.7	3.65	28.3	4.5	32.8	5.5	35.1	6.0	37.4	6.5	41.9	7.7	46.5	8.9		
		23	23.7	3.89	28.3	4.8	32.8	5.8	35.1	6.4	37.4	7.0	41.9	8.2	46.5	9.5		
		25	23.7	4.14	28.3	5.1	32.8	6.2	35.1	6.8	37.4	7.5	41.9	8.8	46.5	10.2		
		27	23.7	4.4	28.3	5.5	32.8	6.7	35.1	7.3	37.4	8.0	41.9	9.4	46.5	10.9		
		29	23.7	4.7	28.3	5.8	32.8	7.1	35.1	7.8	37.4	8.5	41.9	10.0	46.5	11.7		
		31	23.7	5.0	28.3	6.2	32.8	7.5	35.1	8.3	37.4	9.0	41.9	10.7	46.5	12.5		
		33	23.7	5.3	28.3	6.6	32.8	8.0	35.1	8.8	37.4	9.6	41.9	11.4	46.5	13.3		
		35	23.7	5.6	28.3	7.0	32.8	8.5	35.1	9.4	37.4	10.3	41.9	12.1	46.5	14.2		
		37	23.7	5.9	28.3	7.4	32.8	9.1	35.1	10.0	37.4	10.9	41.9	12.9	46.5	14.7		
		39	23.7	6.3	28.3	7.9	32.8	9.7	35.1	10.6	37.4	11.6	41.9	13.8	46.5	15.2		
		120	480 (54.00)	10	21.9	3.08	26.1	3.60	30.3	4.12	32.4	4.4	34.5	4.7	38.7	5.2	42.9	5.7
				12	21.9	3.12	26.1	3.65	30.3	4.19	32.4	4.5	34.5	4.7	38.7	5.3	42.9	5.8
14	21.9			3.17	26.1	3.70	30.3	4.2	32.4	4.5	34.5	4.8	38.7	5.3	42.9	6.1		
16	21.9			3.22	26.1	3.76	30.3	4.3	32.4	4.6	34.5	4.9	38.7	5.7	42.9	6.6		
18	21.9			3.26	26.1	3.82	30.3	4.4	32.4	4.8	34.5	5.3	38.7	6.2	42.9	7.1		
20	21.9			3.31	26.1	3.95	30.3	4.8	32.4	5.2	34.5	5.6	38.7	6.6	42.9	7.6		
21	21.9			3.34	26.1	4.09	30.3	4.9	32.4	5.4	34.5	5.8	38.7	6.8	42.9	7.9		
23	21.9			3.55	26.1	4.4	30.3	5.3	32.4	5.7	34.5	6.2	38.7	7.3	42.9	8.5		
25	21.9			3.77	26.1	4.6	30.3	5.6	32.4	6.1	34.5	6.7	38.7	7.8	42.9	9.1		
27	21.9			4.01	26.1	4.9	30.3	6.0	32.4	6.5	34.5	7.1	38.7	8.4	42.9	9.7		
29	21.9			4.26	26.1	5.3	30.3	6.4	32.4	7.0	34.5	7.6	38.7	8.9	42.9	10.4		
31	21.9			4.5	26.1	5.6	30.3	6.8	32.4	7.4	34.5	8.1	38.7	9.5	42.9	11.1		
33	21.9			4.8	26.1	5.9	30.3	7.2	32.4	7.9	34.5	8.6	38.7	10.1	42.9	11.8		
35	21.9			5.1	26.1	6.3	30.3	7.7	32.4	8.4	34.5	9.2	38.7	10.8	42.9	12.6		
37	21.9			5.4	26.1	6.7	30.3	8.1	32.4	8.9	34.5	9.7	38.7	11.5	42.9	13.4		
39	21.9			5.7	26.1	7.1	30.3	8.6	32.4	9.5	34.5	10.4	38.7	12.2	42.9	14.3		
110	440 (49.50)			10	20.0	2.86	23.9	3.33	27.8	3.81	29.7	4.05	31.6	4.3	35.5	4.8	39.4	5.3
				12	20.0	2.90	23.9	3.38	27.8	3.86	29.7	4.11	31.6	4.4	35.5	4.8	39.4	5.3
		14	20.0	2.94	23.9	3.43	27.8	3.92	29.7	4.17	31.6	4.4	35.5	4.9	39.4	5.4		
		16	20.0	2.98	23.9	3.48	27.8	3.98	29.7	4.2	31.6	4.5	35.5	5.1	39.4	5.9		
		18	20.0	3.03	23.9	3.53	27.8	4.05	29.7	4.3	31.6	4.7	35.5	5.5	39.4	6.3		
		20	20.0	3.07	23.9	3.59	27.8	4.3	29.7	4.6	31.6	5.0	35.5	5.9	39.4	6.8		
		21	20.0	3.10	23.9	3.69	27.8	4.4	29.7	4.8	31.6	5.2	35.5	6.1	39.4	7.0		
		23	20.0	3.23	23.9	3.93	27.8	4.7	29.7	5.1	31.6	5.6	35.5	6.5	39.4	7.5		
		25	20.0	3.43	23.9	4.18	27.8	5.0	29.7	5.5	31.6	5.9	35.5	6.9	39.4	8.0		
		27	20.0	3.64	23.9	4.5	27.8	5.3	29.7	5.8	31.6	6.3	35.5	7.4	39.4	8.6		
		29	20.0	3.86	23.9	4.7	27.8	5.7	29.7	6.2	31.6	6.7	35.5	7.9	39.4	9.1		
		31	20.0	4.09	23.9	5.0	27.8	6.0	29.7	6.6	31.6	7.2	35.5	8.4	39.4	9.7		
		33	20.0	4.33	23.9	5.3	27.8	6.4	29.7	7.0	31.6	7.6	35.5	9.0	39.4	10.4		
		35	20.0	4.6	23.9	5.6	27.8	6.8	29.7	7.5	31.6	8.1	35.5	9.5	39.4	11.1		
		37	20.0	4.9	23.9	6.0	27.8	7.2	29.7	7.9	31.6	8.6	35.5	10.1	39.4	11.8		
		39	20.0	5.1	23.9	6.3	27.8	7.7	29.7	8.4	31.6	9.2	35.5	10.8	39.4	12.5		
		100	400 (45.00)	10	18.2	2.65	21.7	3.07	25.2	3.49	27.0	3.71	28.8	3.93	32.3	4.4	35.8	4.8
				12	18.2	2.68	21.7	3.11	25.2	3.54	27.0	3.77	28.8	3.99	32.3	4.4	35.8	4.9
14	18.2			2.72	21.7	3.15	25.2	3.60	27.0	3.82	28.8	4.05	32.3	4.5	35.8	5.0		
16	18.2			2.76	21.7	3.20	25.2	3.65	27.0	3.88	28.8	4.11	32.3	4.6	35.8	5.1		
18	18.2			2.80	21.7	3.25	25.2	3.71	27.0	3.94	28.8	4.18	32.3	4.8	35.8	5.5		
20	18.2			2.84	21.7	3.30	25.2	3.80	27.0	4.12	28.8	4.5	32.3	5.2	35.8	5.9		
21	18.2			2.86	21.7	3.32	25.2	3.93	27.0	4.3	28.8	4.6	32.3	5.3	35.8	6.1		
23	18.2			2.92	21.7	3.52	25.2	4.19	27.0	4.5	28.8	4.9	32.3	5.7	35.8	6.6		
25	18.2			3.10	21.7	3.75	25.2	4.5	27.0	4.8	28.8	5.2	32.3	6.1	35.8	7.0		
27	18.2			3.29	21.7	3.98	25.2	4.8	27.0	5.2	28.8	5.6	32.3	6.5	35.8	7.5		
29	18.2			3.48	21.7	4.23	25.2	5.1	27.0	5.5	28.8	6.0	32.3	6.9	35.8	8.0		
31	18.2			3.69	21.7	4.5	25.2	5.4	27.0	5.8	28.8	6.3	32.3	7.4	35.8	8.5		
33	18.2			3.90	21.7	4.8	25.2	5.7	27.0	6.2	28.8	6.7	32.3	7.8	35.8	9.1		
35	18.2			4.12	21.7	5.0	25.2	6.0	27.0	6.6	28.8	7.1	32.3	8.3	35.8	9.6		
37	18.2			4.36	21.7	5.3	25.2	6.4	27.0	7.0	28.8	7.6	32.3	8.9	35.8	10.3		
39	18.2			4.6	21.7	5.6	25.2	6.8	27.0	7.4	28.8	8.1	32.3	9.4	35.8	10.9		

4TW33912-3A(9)

4 Capacity tables

4 - 1 Cooling Capacity Tables

RXYRQ16P - Correction factor for mixed connection: 0.6

TC: Total Capacity: kW ; PI: Power Input: kW (compressor + outdoor fan motor)

Combination (%)	Capacity index (kW)	Outdoor air temp. °CDB	Indoor air temperature:															
			14.0 °CWB		16.0 °CWB		18.0 °CWB		19.0 °CWB		20.0 °CWB		22.0 °CWB		24.0 °CWB			
			20.0 °CDB		23.0 °CDB		16.0 °CDB		27.0 °CDB		28.0 °CDB		30.0 °CDB		32.0 °CDB			
			TC	PI	TC	PI	TC	PI	TC	PI	TC	PI	TC	PI	TC	PI		
90	360 (40.50)	10	16,4	2,44	19,6	2,81	22,7	3,18	24,3	3,38	25,9	3,57	29,0	3,97	32,2	4,4		
		12	16,4	2,47	19,6	2,84	22,7	3,23	24,3	3,43	25,9	3,63	29,0	4,03	32,2	4,4		
		14	16,4	2,50	19,6	2,88	22,7	3,28	24,3	3,48	25,9	3,68	29,0	4,09	32,2	4,5		
		16	16,4	2,54	19,6	2,92	22,7	3,32	24,3	3,53	25,9	3,74	29,0	4,15	32,2	4,6		
		18	16,4	2,57	19,6	2,97	22,7	3,37	24,3	3,58	25,9	3,79	29,0	4,2	32,2	4,8		
		20	16,4	2,60	19,6	3,01	22,7	3,43	24,3	3,64	25,9	3,92	29,0	4,5	32,2	5,2		
		21	16,4	2,62	19,6	3,03	22,7	3,48	24,3	3,76	25,9	4,05	29,0	4,7	32,2	5,3		
		23	16,4	2,66	19,6	3,14	22,7	3,71	24,3	4,01	25,9	4,3	29,0	5,0	32,2	5,7		
		25	16,4	2,79	19,6	3,34	22,7	3,94	24,3	4,27	25,9	4,6	29,0	5,3	32,2	6,1		
		27	16,4	2,95	19,6	3,54	22,7	4,19	24,3	4,5	25,9	4,9	29,0	5,7	32,2	6,5		
		29	16,4	3,13	19,6	3,76	22,7	4,5	24,3	4,8	25,9	5,2	29,0	6,0	32,2	6,9		
		31	16,4	3,31	19,6	3,98	22,7	4,7	24,3	5,1	25,9	5,5	29,0	6,4	32,2	7,4		
		33	16,4	3,49	19,6	4,22	22,7	5,0	24,3	5,4	25,9	5,9	29,0	6,8	32,2	7,8		
		35	16,4	3,69	19,6	4,5	22,7	5,3	24,3	5,8	25,9	6,2	29,0	7,2	32,2	8,3		
		37	16,4	3,90	19,6	4,7	22,7	5,6	24,3	6,1	25,9	6,6	29,0	7,7	32,2	8,8		
		39	16,4	4,11	19,6	5,0	22,7	6,0	24,3	6,5	25,9	7,0	29,0	8,2	32,2	9,4		
		80	320 (36.00)	10	14,6	2,24	17,4	2,55	20,2	2,88	21,6	3,05	23,0	3,22	25,8	3,56	28,6	3,91
				12	14,6	2,26	17,4	2,59	20,2	2,92	21,6	3,09	23,0	3,27	25,8	3,62	28,6	3,97
				14	14,6	2,29	17,4	2,62	20,2	2,96	21,6	3,14	23,0	3,31	25,8	3,67	28,6	4,03
16	14,6			2,32	17,4	2,65	20,2	3,00	21,6	3,18	23,0	3,36	25,8	3,73	28,6	4,10		
18	14,6			2,35	17,4	2,69	20,2	3,05	21,6	3,23	23,0	3,41	25,8	3,78	28,6	4,16		
20	14,6			2,38	17,4	2,73	20,2	3,09	21,6	3,28	23,0	3,46	25,8	3,91	28,6	4,4		
21	14,6			2,39	17,4	2,75	20,2	3,12	21,6	3,30	23,0	3,53	25,8	4,04	28,6	4,6		
23	14,6			2,43	17,4	2,79	20,2	3,25	21,6	3,50	23,0	3,76	25,8	4,3	28,6	4,9		
25	14,6			2,49	17,4	2,95	20,2	3,46	21,6	3,72	23,0	4,00	25,8	4,6	28,6	5,2		
27	14,6			2,64	17,4	3,13	20,2	3,67	21,6	3,96	23,0	4,25	25,8	4,9	28,6	5,6		
29	14,6			2,79	17,4	3,32	20,2	3,89	21,6	4,20	23,0	4,5	25,8	5,2	28,6	5,9		
31	14,6			2,95	17,4	3,51	20,2	4,13	21,6	4,5	23,0	4,8	25,8	5,5	28,6	6,3		
33	14,6			3,11	17,4	3,71	20,2	4,37	21,6	4,7	23,0	5,1	25,8	5,9	28,6	6,7		
35	14,6			3,28	17,4	3,92	20,2	4,6	21,6	5,0	23,0	5,4	25,8	6,2	28,6	7,1		
37	14,6			3,46	17,4	4,14	20,2	4,9	21,6	5,3	23,0	5,7	25,8	6,6	28,6	7,5		
39	14,6			3,65	17,4	4,37	20,2	5,2	21,6	5,6	23,0	6,0	25,8	7,0	28,6	8,0		

4TW33912-3A(10)

NOTES - ANMERKUNGEN - Σημειώσεις - NOTAS - REMARQUES - NOTE - OPMERKINGEN - Примечания - NOTLAR

- The above table shows the average value of conditions which may occur.
Die obige Tabelle zeigt den Durchschnittswert der Bedingungen, die auftreten können.
Στον παραπάνω πίνακα αναγράφεται η μέση τιμή για συνθήκες που μπορεί να προκύψουν.
La tabla de arriba muestra el valor medio de condiciones que pueden ocurrir.
Le tableau ci-dessus donne la valeur moyenne pour des conditions qui peuvent survenir.
La tabella in alto mostra il valore delle condizioni medie che si possono riscontrare.
De tabel hierboven geeft de gemiddelde waarde aan van situaties die kunnen voorvallen.
Таблица расположенная выше показывает среднее значение условий, которые могут наступить.
Yukarıdaki tablo meydana gelebilecek koşulların ortalama değerini göstermektedir.
- Correction factor for mixed connection: 0.6. For more information refer to the selection procedure.
Korrekturfaktoren für gemischten Anschluss: 0,6. Weitere Informationen finden Sie im Auswahlverfahren.
Συντελεστής διόρθωσης για συνδυαζόμενη σύνδεση: 0,6. Για περισσότερες πληροφορίες ανατρέξτε στη διαδικασία επιλογής.
Factor de corrección para conexión combinada: 0,6. Si desea más información, consulte el procedimiento de selección.
Facteur de correction pour connexion d'unités mixtes : 0,6. Pour plus d'informations, se reporter à la procédure de sélection.
Fattore di correzione per collegamento varie unità: 0,6. Per maggiori informazioni fare riferimento alla procedura di selezione.
Correctiefactor voor gemengde aansluiting: 0,6. Zie selectieprocedure voor meer informatie.
Поправочный коэффициент для комбинированного соединения: 0,7. Подробная информация приводится в разделе порядка выбора.
Karışık bağlantı için düzeltme faktörü: 0.7. Daha fazla bilgi için, seçim prosedürüne bakın.

4 Capacity tables

4 - 1 Cooling Capacity Tables

RXYRQ18P - Correction factor for mixed connection: 1.0

TC: Total Capacity: kW ; PI: Power Input: kW (compressor + outdoor fan motor)

Combination (%)	Capacity index (kW)	Outdoor air temp. °CDB	Indoor air temperature:													
			14.0 °CWB		16.0 °CWB		18.0 °CWB		19.0 °CWB		20.0 °CWB		22.0 °CWB		24.0 °CWB	
			20.0 °CDB		23.0 °CDB		16.0 °CDB		27.0 °CDB		28.0 °CDB		30.0 °CDB		32.0 °CDB	
			TC	PI	TC	PI	TC	PI	TC	PI	TC	PI	TC	PI	TC	PI
90	405 (44.10)	10	29.8	4.72	35.5	5.69	41.2	6.72	44.1	7.25	47.0	7.79	52.7	8.90	58.4	10.0
		12	29.8	4.80	35.5	5.79	41.2	6.84	44.1	7.39	47.0	7.94	52.7	9.07	58.4	10.2
		14	29.8	4.88	35.5	5.90	41.2	6.97	44.1	7.53	47.0	8.09	52.7	9.24	58.4	10.4
		16	29.8	4.97	35.5	6.01	41.2	7.10	44.1	7.67	47.0	8.25	52.7	9.43	58.3	10.6
		18	29.8	5.06	35.5	6.12	41.2	7.24	44.1	7.82	47.0	8.41	52.7	9.61	57.5	10.9
		20	29.8	5.15	35.5	6.24	41.2	7.39	44.1	7.98	47.0	8.73	52.7	10.3	56.7	11.5
		21	29.8	5.20	35.5	6.30	41.2	7.51	44.1	8.26	47.0	9.04	52.7	10.7	56.3	11.7
		23	29.8	5.30	35.5	6.56	41.2	8.04	44.1	8.84	47.0	9.68	52.7	11.5	55.5	12.3
		25	29.8	5.58	35.5	7.00	41.2	8.60	44.1	9.46	47.0	10.4	52.7	12.3	54.8	12.8
		27	29.8	5.94	35.5	7.47	41.2	9.18	44.1	10.1	47.0	11.1	52.7	13.1	54.0	13.3
		29	29.8	6.32	35.5	7.96	41.2	9.80	44.1	10.8	47.0	11.8	52.1	13.8	53.2	13.9
		31	29.8	6.72	35.5	8.48	41.2	10.4	44.1	11.5	47.0	12.6	51.3	14.3	52.4	14.4
		33	29.8	7.14	35.5	9.02	41.2	11.1	44.1	12.3	47.0	13.5	50.5	14.8	51.6	15.0
		35	29.8	7.58	35.5	9.59	41.2	11.8	44.1	13.1	47.0	14.4	49.7	15.4	50.8	15.5
		37	29.8	8.04	35.5	10.2	41.2	12.6	44.1	13.9	47.0	15.3	48.9	15.9	50.0	16.1
		39	29.8	8.53	35.5	10.8	41.2	13.4	44.1	14.8	47.0	16.3	48.1	16.5	49.2	16.6
		80	360 (39.20)	10	26.5	4.19	31.6	5.02	36.7	5.89	39.2	6.35	41.7	6.81	46.8	7.77
12	26.5			4.26	31.6	5.10	36.7	6.00	39.2	6.47	41.7	6.94	46.8	7.92	51.9	8.92
14	26.5			4.33	31.6	5.19	36.7	6.11	39.2	6.59	41.7	7.07	46.8	8.07	51.9	9.09
16	26.5			4.40	31.6	5.29	36.7	6.22	39.2	6.71	41.7	7.21	46.8	8.22	51.9	9.27
18	26.5			4.48	31.6	5.38	36.7	6.34	39.2	6.84	41.7	7.35	46.8	8.39	51.9	9.45
20	26.5			4.56	31.6	5.48	36.7	6.47	39.2	6.97	41.7	7.49	46.8	8.69	51.9	10.1
21	26.5			4.60	31.6	5.54	36.7	6.53	39.2	7.04	41.7	7.65	46.8	9.00	51.9	10.5
23	26.5			4.68	31.6	5.64	36.7	6.85	39.2	7.50	41.7	8.18	46.8	9.65	51.9	11.2
25	26.5			4.83	31.6	6.01	36.7	7.31	39.2	8.01	41.7	8.75	46.8	10.3	51.9	12.0
27	26.5			5.14	31.6	6.40	36.7	7.80	39.2	8.55	41.7	9.34	46.8	11.0	51.9	12.9
29	26.5			5.46	31.6	6.81	36.7	8.31	39.2	9.12	41.7	9.97	46.8	11.8	51.9	13.7
31	26.5			5.80	31.6	7.24	36.7	8.85	39.2	9.72	41.7	10.6	46.8	12.6	51.1	14.3
33	26.5			6.16	31.6	7.70	36.7	9.42	39.2	10.4	41.7	11.3	46.8	13.4	50.3	14.8
35	26.5			6.53	31.6	8.18	36.7	10.0	39.2	11.0	41.7	12.1	46.8	14.3	49.6	15.4
37	26.5			6.92	31.6	8.69	36.7	10.7	39.2	11.7	41.7	12.8	46.8	15.2	48.8	15.9
39	26.5			7.33	31.6	9.22	36.7	11.3	39.2	12.5	41.7	13.7	46.8	16.2	48.0	16.4

4TW33912-3A(2)

NOTES - ANMERKUNGEN - Σημειώσεις - NOTAS - REMARQUES - NOTE - OPMERKINGEN - Примечания - NOTLAR

- The above table shows the average value of conditions which may occur.
Die obige Tabelle zeigt den Durchschnittswert der Bedingungen, die auftreten können.
Στον παραπάνω πίνακα αναγράφεται η μέση τιμή για συνθήκες που μπορεί να προκύψουν.
La tabla de arriba muestra el valor medio de condiciones que pueden ocurrir.
Le tableau ci-dessus donne la valeur moyenne pour des conditions qui peuvent survenir.
La tabella in alto mostra il valore delle condizioni medie che si possono riscontrare.
De tabel hierboven geeft de gemiddelde waarde aan van situaties die kunnen voorvallen.
Таблица расположенная выше показывает среднее значение условий, которые могут наступить.
Yukarıdaki tablo meydana gelebilecek koşulların ortalama değerini göstermektedir.
- Correction factor for mixed connection: 1.0. For more information refer to the selection procedure.
Korrekturfaktoren für gemischten Anschluss: 1,0. Weitere Informationen finden Sie im Auswahlverfahren.
Συντελεστής διόρθωσης για συνδυαζόμενη σύνδεση: 1,0. Για περισσότερες πληροφορίες ανατρέξτε στη διαδικασία επιλογής.
Factor de corrección para conexión combinada: 1,0. Si desea más información, consulte el procedimiento de selección.
Facteur de correction pour connexion d'unités mixtes : 1,0. Pour plus d'informations, se reporter à la procédure de sélection.
Fattore di correzione per collegamento varie unità: 1,0. Per maggiori informazioni fare riferimento alla procedura di selezione.
Correctiefactor voor gemengde aansluiting: 1,0. Zie selectieprocedure voor meer informatie.
Поправочный коэффициент для комбинированного соединения: 1,0. Подробная информация приводится в разделе порядка выбора.
Karışık bağlantı için düzeltme faktörü: 1.0. Daha fazla bilgi için, seçim prosedürüne bakın.

4 Capacity tables

4 - 1 Cooling Capacity Tables

RXYRQ18P - Correction factor for mixed connection: 0.9

TC: Total Capacity: kW ; PI: Power Input: kW (compressor + outdoor fan motor)

Combination (%)	Capacity index (kW)	Outdoor air temp. °CDB	Indoor air temperature:													
			14.0 °CWB		16.0 °CWB		18.0 °CWB		19.0 °CWB		20.0 °CWB		22.0 °CWB		24.0 °CWB	
			20.0 °CDB		23.0 °CDB		16.0 °CDB		27.0 °CDB		28.0 °CDB		30.0 °CDB		32.0 °CDB	
		TC	PI	TC	PI	TC	PI	TC	PI	TC	PI	TC	PI	TC	PI	
130	585 (63.70)	10	38.7	6.12	46.1	7.43	53.6	8.8	57.3	9.5	61.1	10.1	64.0	9.83	65.6	9.39
		12	38.7	6.23	46.1	7.56	53.6	8.9	57.3	9.6	61.1	10.2	63.2	9.76	64.8	9.61
		14	38.7	6.34	46.1	7.70	53.6	9.1	57.3	9.8	60.9	10.1	62.4	10.1	64.0	10.2
		16	38.7	6.45	46.1	7.84	53.6	9.3	57.3	10.1	60.1	10.5	61.6	10.6	63.2	10.7
		18	38.7	6.58	46.1	7.99	53.6	9.9	57.3	10.9	59.3	11.0	60.9	11.1	62.4	11.3
		20	38.7	6.70	46.1	8.51	53.6	10.6	57.3	11.5	58.5	11.6	60.1	11.7	61.6	11.8
		21	38.7	6.89	46.1	8.8	53.6	11.0	57.3	11.8	58.1	11.9	59.7	12.0	61.2	12.1
		23	38.7	7.37	46.1	9.4	53.6	11.8	56.5	12.3	57.3	12.4	58.9	12.5	60.4	12.6
		25	38.7	7.87	46.1	10.1	53.6	12.6	55.7	12.9	56.5	12.9	58.1	13.1	59.6	13.2
		27	38.7	8.40	46.1	10.8	53.6	13.3	54.9	13.4	55.7	13.5	57.3	13.6	58.8	13.8
		29	38.7	9.0	46.1	11.5	53.4	13.9	54.1	14.0	54.9	14.0	56.5	14.2	58.0	14.3
		31	38.7	9.5	46.1	12.3	52.6	14.4	53.3	14.5	54.1	14.6	55.7	14.7	57.2	14.9
		33	38.7	10.2	46.1	13.1	51.8	15.0	52.5	15.1	53.3	15.1	54.9	15.3	56.4	15.5
		35	38.7	10.8	46.1	14.0	51.0	15.5	51.8	15.6	52.5	15.7	54.1	15.9	55.6	16.1
		37	38.7	11.5	46.1	14.9	50.2	16.1	51.0	16.2	51.7	16.3	53.3	16.4	54.8	16.6
		39	38.7	12.2	46.1	15.9	49.4	16.6	50.2	16.7	50.9	16.8	52.5	17.0	54.0	17.2
120	540 (58.80)	10	35.7	5.61	42.6	6.80	49.5	8.02	52.9	8.6	56.4	9.3	62.9	10.1	64.4	9.73
		12	35.7	5.71	42.6	6.92	49.5	8.17	52.9	8.8	56.4	9.4	62.1	10.1	63.6	9.67
		14	35.7	5.81	42.6	7.04	49.5	8.32	52.9	9.0	56.4	9.6	61.3	10.0	62.8	10.1
		16	35.7	5.92	42.6	7.18	49.5	8.48	52.9	9.1	56.4	9.9	60.6	10.5	62.0	10.6
		18	35.7	6.03	42.6	7.31	49.5	8.8	52.9	9.7	56.4	10.6	59.8	11.1	61.2	11.2
		20	35.7	6.14	42.6	7.60	49.5	9.4	52.9	10.4	56.4	11.4	59.0	11.6	60.4	11.7
		21	35.7	6.20	42.6	7.86	49.5	9.7	52.9	10.8	56.4	11.8	58.6	11.9	60.0	12.0
		23	35.7	6.61	42.6	8.42	49.5	10.4	52.9	11.5	56.3	12.3	57.8	12.4	59.2	12.5
		25	35.7	7.06	42.6	9.0	49.5	11.2	52.9	12.4	55.5	12.9	57.0	13.0	58.4	13.1
		27	35.7	7.53	42.6	9.6	49.5	12.0	52.9	13.2	54.7	13.4	56.2	13.5	57.6	13.7
		29	35.7	8.03	42.6	10.3	49.5	12.8	52.9	13.9	53.9	13.9	55.4	14.1	56.8	14.2
		31	35.7	8.55	42.6	10.9	49.5	13.6	52.4	14.4	53.1	14.5	54.6	14.6	56.0	14.8
		33	35.7	9.1	42.6	11.7	49.5	14.6	51.6	15.0	52.3	15.0	53.8	15.2	55.2	15.3
		35	35.7	9.7	42.6	12.4	49.5	15.4	50.8	15.5	51.5	15.6	53.0	15.8	54.4	15.9
		37	35.7	10.3	42.6	13.2	49.3	16.0	50.0	16.1	50.8	16.1	52.2	16.3	53.6	16.5
		39	35.7	10.9	42.6	14.1	48.5	16.5	49.2	16.6	50.0	16.7	51.4	16.9	52.8	17.1
110	495 (53.90)	10	32.7	5.12	39.0	6.18	45.4	7.28	48.5	7.85	51.7	8.42	58.0	9.6	63.2	10.1
		12	32.7	5.21	39.0	6.29	45.4	7.42	48.5	7.99	51.7	8.6	58.0	9.7	62.4	10.0
		14	32.7	5.30	39.0	6.40	45.4	7.55	48.5	8.14	51.7	8.7	58.0	9.9	61.6	10.0
		16	32.7	5.39	39.0	6.52	45.4	7.69	48.5	8.29	51.7	8.9	58.0	10.3	60.8	10.5
		18	32.7	5.49	39.0	6.64	45.4	7.84	48.5	8.51	51.7	9.3	58.0	11.0	60.0	11.1
		20	32.7	5.59	39.0	6.77	45.4	8.30	48.5	9.1	51.7	10.0	57.9	11.5	59.2	11.6
		21	32.7	5.64	39.0	6.97	45.4	8.6	48.5	9.5	51.7	10.4	57.5	11.8	58.8	11.9
		23	32.7	5.90	39.0	7.46	45.4	9.2	48.5	10.1	51.7	11.1	56.7	12.3	58.0	12.4
		25	32.7	6.30	39.0	7.97	45.4	9.8	48.5	10.9	51.7	11.9	55.9	12.9	57.2	13.0
		27	32.7	6.71	39.0	8.51	45.4	10.5	48.5	11.6	51.7	12.8	55.1	13.4	56.4	13.5
		29	32.7	7.15	39.0	9.1	45.4	11.2	48.5	12.4	51.7	13.6	54.3	14.0	55.6	14.1
		31	32.7	7.60	39.0	9.7	45.4	12.0	48.5	13.2	51.7	14.4	53.5	14.5	54.8	14.7
		33	32.7	8.08	39.0	10.3	45.4	12.8	48.5	14.1	51.4	14.9	52.7	15.1	54.0	15.2
		35	32.7	8.59	39.0	11.0	45.4	13.6	48.5	15.1	50.6	15.5	51.9	15.6	53.2	15.8
		37	32.7	9.1	39.0	11.7	45.4	14.5	48.5	15.9	49.8	16.0	51.1	16.2	52.4	16.3
		39	32.7	9.7	39.0	12.4	45.4	15.5	48.3	16.5	49.0	16.6	50.3	16.7	51.6	16.9
100	450 (49.00)	10	29.8	4.64	35.5	5.58	41.2	6.56	44.1	7.06	47.0	7.57	52.7	8.6	58.4	9.7
		12	29.8	4.72	35.5	5.67	41.2	6.67	44.1	7.19	47.0	7.71	52.7	8.8	58.4	9.8
		14	29.8	4.80	35.5	5.77	41.2	6.80	44.1	7.32	47.0	7.85	52.7	8.9	58.4	10.0
		16	29.8	4.88	35.5	5.88	41.2	6.92	44.1	7.46	47.0	8.00	52.7	9.1	58.4	10.4
		18	29.8	4.97	35.5	5.99	41.2	7.05	44.1	7.60	47.0	8.15	52.7	9.6	58.4	11.0
		20	29.8	5.06	35.5	6.10	41.2	7.26	44.1	7.98	47.0	8.7	52.7	10.3	58.0	11.5
		21	29.8	5.10	35.5	6.16	41.2	7.51	44.1	8.26	47.0	9.0	52.7	10.7	57.6	11.8
		23	29.8	5.23	35.5	6.56	41.2	8.04	44.1	8.8	47.0	9.7	52.7	11.5	56.8	12.4
		25	29.8	5.58	35.5	7.00	41.2	8.60	44.1	9.5	47.0	10.4	52.7	12.3	56.0	12.9
		27	29.8	5.94	35.5	7.47	41.2	9.2	44.1	10.1	47.0	11.1	52.7	13.1	55.2	13.4
		29	29.8	6.32	35.5	7.96	41.2	9.8	44.1	10.8	47.0	11.8	52.7	13.9	54.4	14.0
		31	29.8	6.72	35.5	8.48	41.2	10.4	44.1	11.5	47.0	12.6	52.4	14.4	53.6	14.5
		33	29.8	7.14	35.5	9.0	41.2	11.1	44.1	12.3	47.0	13.5	51.6	15.0	52.8	15.1
		35	29.8	7.58	35.5	9.6	41.2	11.8	44.1	13.1	47.0	14.4	50.8	15.5	52.0	15.6
		37	29.8	8.04	35.5	10.2	41.2	12.6	44.1	13.9	47.0	15.3	50.0	16.1	51.2	16.2
		39	29.8	8.53	35.5	10.8	41.2	13.4	44.1	14.8	47.0	16.3	49.2	16.6	50.4	16.8

4TW33912-3A(3)

4 Capacity tables

4 - 1 Cooling Capacity Tables

RXYRQ18P - Correction factor for mixed connection: 0.9

TC: Total Capacity: kW ; PI: Power Input: kW (compressor + outdoor fan motor)

Combination (%)	Capacity index (kW)	Outdoor air temp. °CDB	Indoor air temperature:													
			14.0 °CWB		16.0 °CWB		18.0 °CWB		19.0 °CWB		20.0 °CWB		22.0 °CWB		24.0 °CWB	
			TC	PI	TC	PI	TC	PI	TC	PI	TC	PI	TC	PI	TC	PI
90	405 (44.10)	10	26.8	4.18	31.9	4.99	37.1	5.85	39.7	6.29	42.3	6.74	47.4	7.66	52.6	8.6
		12	26.8	4.25	31.9	5.08	37.1	5.95	39.7	6.40	42.3	6.86	47.4	7.79	52.6	8.7
		14	26.8	4.32	31.9	5.16	37.1	6.06	39.7	6.52	42.3	6.99	47.4	7.94	52.6	8.9
		16	26.8	4.39	31.9	5.25	37.1	6.17	39.7	6.64	42.3	7.12	47.4	8.09	52.6	9.1
		18	26.8	4.46	31.9	5.35	37.1	6.28	39.7	6.76	42.3	7.25	47.4	8.24	52.6	9.6
		20	26.8	4.54	31.9	5.45	37.1	6.40	39.7	6.89	42.3	7.52	47.4	8.9	52.6	10.3
		21	26.8	4.58	31.9	5.50	37.1	6.51	39.7	7.13	42.3	7.78	47.4	9.2	52.6	10.7
		23	26.8	4.66	31.9	5.72	37.1	6.96	39.7	7.63	42.3	8.33	47.4	9.8	52.6	11.4
		25	26.8	4.91	31.9	6.10	37.1	7.43	39.7	8.15	42.3	8.9	47.4	10.5	52.6	12.3
		27	26.8	5.22	31.9	6.50	37.1	7.93	39.7	8.7	42.3	9.5	47.4	11.2	52.6	13.1
		29	26.8	5.55	31.9	6.92	37.1	8.46	39.7	9.3	42.3	10.1	47.4	12.0	52.6	13.9
		31	26.8	5.89	31.9	7.36	37.1	9.0	39.7	9.9	42.3	10.8	47.4	12.8	52.4	14.4
		33	26.8	6.25	31.9	7.83	37.1	9.6	39.7	10.5	42.3	11.5	47.4	13.7	51.6	15.0
		35	26.8	6.63	31.9	8.32	37.1	10.2	39.7	11.2	42.3	12.3	47.4	14.6	50.8	15.5
		37	26.8	7.03	31.9	8.8	37.1	10.8	39.7	11.9	42.3	13.1	47.4	15.5	50.0	16.1
		39	26.8	7.45	31.9	9.4	37.1	11.5	39.7	12.7	42.3	13.9	47.4	16.5	49.2	16.6
80	360 (39.20)	10	23.8	3.73	28.4	4.43	33.0	5.16	35.3	5.54	37.6	5.93	42.2	6.72	46.8	7.53
		12	23.8	3.79	28.4	4.50	33.0	5.25	35.3	5.64	37.6	6.03	42.2	6.84	46.8	7.67
		14	23.8	3.85	28.4	4.57	33.0	5.34	35.3	5.74	37.6	6.14	42.2	6.97	46.8	7.81
		16	23.8	3.91	28.4	4.65	33.0	5.44	35.3	5.84	37.6	6.25	42.2	7.10	46.8	7.96
		18	23.8	3.98	28.4	4.73	33.0	5.53	35.3	5.95	37.6	6.37	42.2	7.23	46.8	8.11
		20	23.8	4.04	28.4	4.82	33.0	5.64	35.3	6.06	37.6	6.49	42.2	7.49	46.8	8.7
		21	23.8	4.08	28.4	4.86	33.0	5.69	35.3	6.12	37.6	6.62	42.2	7.75	46.8	9.0
		23	23.8	4.15	28.4	4.95	33.0	5.96	35.3	6.51	37.6	7.08	42.2	8.30	46.8	9.6
		25	23.8	4.28	28.4	5.26	33.0	6.36	35.3	6.95	37.6	7.56	42.2	8.9	46.8	10.3
		27	23.8	4.55	28.4	5.60	33.0	6.78	35.3	7.41	37.6	8.07	42.2	9.5	46.8	11.0
		29	23.8	4.83	28.4	5.96	33.0	7.22	35.3	7.89	37.6	8.60	42.2	10.1	46.8	11.7
		31	23.8	5.12	28.4	6.33	33.0	7.68	35.3	8.40	37.6	9.2	42.2	10.8	46.8	12.5
		33	23.8	5.43	28.4	6.72	33.0	8.17	35.3	8.9	37.6	9.8	42.2	11.5	46.8	13.4
		35	23.8	5.75	28.4	7.14	33.0	8.7	35.3	9.5	37.6	10.4	42.2	12.2	46.8	14.3
		37	23.8	6.09	28.4	7.57	33.0	9.2	35.3	10.1	37.6	11.0	42.2	13.0	46.8	15.2
		39	23.8	6.44	28.4	8.03	33.0	9.8	35.3	10.7	37.6	11.7	42.2	13.9	46.8	16.2

4TW33912-3A(4)

NOTES - ANMERKUNGEN - Σημειώσεις - NOTAS - REMARQUES - NOTE - OPMERKINGEN - Примечания - NOTLAR

- The above table shows the average value of conditions which may occur.
Die obige Tabelle zeigt den Durchschnittswert der Bedingungen, die auftreten können.
Στον παραπάνω πίνακα αναγράφεται η μέση τιμή για συνθήκες που μπορεί να προκύψουν.
La tabla de arriba muestra el valor medio de condiciones que pueden ocurrir.
Le tableau ci-dessus donne la valeur moyenne pour des conditions qui peuvent survenir.
La tabella in alto mostra il valore delle condizioni medie che si possono riscontrare.
De tabel hierboven geeft de gemiddelde waarde aan van situaties die kunnen voorvallen.
Таблица расположенная выше показывает среднее значение условий, которые могут наступить.
Yukarıdaki tablo meydana gelebilecek koşulların ortalama değerini göstermektedir.
- Correction factor for mixed connection: 0.9. For more information refer to the selection procedure.
Korrekturfaktoren für gemischten Anschluss: 0,9. Weitere Informationen finden Sie im Auswahlverfahren.
Συντελεστής διόρθωσης για συνδυαζόμενη σύνδεση: 0,9. Για περισσότερες πληροφορίες ανατρέξτε στη διαδικασία επιλογής.
Factor de corrección para conexión combinada: 0,9. Si desea más información, consulte el procedimiento de selección.
Facteur de correction pour connexion d'unités mixtes : 0,9. Pour plus d'informations, se reporter à la procédure de sélection.
Fattore di correzione per collegamento varie unità: 0,9. Per maggiori informazioni fare riferimento alla procedura di selezione.
Correctiefactor voor gemengde aansluiting: 0,9. Zie selectieprocedure voor meer informatie.
Поправочный коэффициент для комбинированного соединения: 0,9. Подробная информация приводится в разделе порядка выбора.
Karışık bağlantı için düzeltme faktörü: 0.9. Daha fazla bilgi için, seçim prosedürüne bakın.

4 Capacity tables

4 - 1 Cooling Capacity Tables

RXYRQ18P - Correction factor for mixed connection: 0.8

TC: Total Capacity: kW ; PI: Power Input: kW (compressor + outdoor fan motor)

Combination (%)	Capacity index (kW)	Outdoor air temp. °CDB	Indoor air temperature:															
			14.0 °CWB		16.0 °CWB		18.0 °CWB		19.0 °CWB		20.0 °CWB		22.0 °CWB		24.0 °CWB			
			20.0 °CDB		23.0 °CDB		16.0 °CDB		27.0 °CDB		28.0 °CDB		30.0 °CDB		32.0 °CDB			
			TC	PI	TC	PI	TC	PI	TC	PI	TC	PI	TC	PI	TC	PI		
130	585 (63.70)	10	34.4	5.26	41.0	6.32	47.6	7.4	51.0	8.0	54.3	8.5	60.9	9.58	65.6	9.39		
		12	34.4	5.35	41.0	6.43	47.6	7.5	51.0	8.1	54.3	8.6	60.9	9.74	64.8	9.61		
		14	34.4	5.44	41.0	6.54	47.6	7.7	51.0	8.2	54.3	8.8	60.9	10.1	64.0	10.2		
		16	34.4	5.53	41.0	6.66	47.6	7.8	51.0	8.5	54.3	9.3	60.9	10.6	63.2	10.7		
		18	34.4	5.63	41.0	6.78	47.6	8.3	51.0	9.1	54.3	10.0	60.9	11.1	62.4	11.3		
		20	34.4	5.73	41.0	7.21	47.6	8.9	51.0	9.8	54.3	10.8	60.1	11.7	61.6	11.8		
		21	34.4	5.89	41.0	7.5	47.6	9.2	51.0	10.2	54.3	11.2	59.7	12.0	61.2	12.1		
		23	34.4	6.29	41.0	8.0	47.6	9.9	51.0	10.9	54.3	12.0	58.9	12.5	60.4	12.6		
		25	34.4	6.72	41.0	8.5	47.6	10.6	51.0	11.7	54.3	12.8	58.1	13.1	59.6	13.2		
		27	34.4	7.16	41.0	9.1	47.6	11.3	51.0	12.5	54.3	13.5	57.3	13.6	58.8	13.8		
		29	34.4	7.6	41.0	9.7	47.6	12.1	51.0	13.4	54.3	14.0	56.5	14.2	58.0	14.3		
		31	34.4	8.1	41.0	10.4	47.6	12.9	51.0	14.3	54.1	14.6	55.7	14.7	57.2	14.9		
		33	34.4	8.6	41.0	11.0	47.6	13.8	51.0	15.1	53.3	15.1	54.9	15.3	56.4	15.5		
		35	34.4	9.2	41.0	11.8	47.6	14.7	51.0	15.6	52.5	15.7	54.1	15.9	55.6	16.1		
		37	34.4	9.8	41.0	12.5	47.6	15.6	51.0	16.2	51.7	16.3	53.3	16.4	54.8	16.6		
		39	34.4	10.4	41.0	13.3	47.6	16.6	50.2	16.7	50.9	16.8	52.5	17.0	54.0	17.2		
120	540 (58.80)	10	31.7	4.85	37.9	5.81	44.0	6.80	47.0	7.3	50.1	7.8	56.2	8.8	62.3	9.73		
		12	31.7	4.93	37.9	5.91	44.0	6.92	47.0	7.4	50.1	7.9	56.2	9.0	62.3	9.67		
		14	31.7	5.01	37.9	6.01	44.0	7.04	47.0	7.6	50.1	8.1	56.2	9.1	62.3	10.1		
		16	31.7	5.10	37.9	6.12	44.0	7.17	47.0	7.7	50.1	8.3	56.2	9.8	62.0	10.6		
		18	31.7	5.18	37.9	6.23	44.0	7.4	47.0	8.1	50.1	8.9	56.2	10.6	61.2	11.2		
		20	31.7	5.28	37.9	6.46	44.0	7.9	47.0	8.7	50.1	9.6	56.2	11.4	60.4	11.7		
		21	31.7	5.32	37.9	6.69	44.0	8.2	47.0	9.1	50.1	9.9	56.2	11.8	60.0	12.0		
		23	31.7	5.68	37.9	7.15	44.0	8.8	47.0	9.7	50.1	10.6	56.2	12.4	59.2	12.5		
		25	31.7	6.05	37.9	7.6	44.0	9.4	47.0	10.4	50.1	11.4	56.2	13.0	58.4	13.1		
		27	31.7	6.45	37.9	8.2	44.0	10.1	47.0	11.1	50.1	12.2	56.2	13.5	57.6	13.7		
		29	31.7	6.87	37.9	8.7	44.0	10.7	47.0	11.9	50.1	13.0	55.4	14.1	56.8	14.2		
		31	31.7	7.30	37.9	9.3	44.0	11.5	47.0	12.7	50.1	13.9	54.6	14.6	56.0	14.8		
		33	31.7	7.8	37.9	9.9	44.0	12.2	47.0	13.5	50.1	14.8	53.8	15.2	55.2	15.3		
		35	31.7	8.2	37.9	10.5	44.0	13.0	47.0	14.4	50.1	15.6	53.0	15.8	54.4	15.9		
		37	31.7	8.8	37.9	11.2	44.0	13.9	47.0	15.3	50.1	16.1	52.2	16.3	53.6	16.5		
		39	31.7	9.3	37.9	11.9	44.0	14.8	47.0	16.3	50.0	16.7	51.4	16.9	52.8	17.1		
110	495 (53.90)	10	29.1	4.45	34.7	5.31	40.3	6.21	43.1	6.66	45.9	7.12	51.5	8.1	57.1	9.0		
		12	29.1	4.52	34.7	5.40	40.3	6.31	43.1	6.78	45.9	7.2	51.5	8.2	57.1	9.1		
		14	29.1	4.59	34.7	5.49	40.3	6.42	43.1	6.90	45.9	7.4	51.5	8.3	57.1	9.3		
		16	29.1	4.67	34.7	5.59	40.3	6.54	43.1	7.02	45.9	7.5	51.5	8.6	57.1	10.1		
		18	29.1	4.75	34.7	5.68	40.3	6.66	43.1	7.20	45.9	7.9	51.5	9.3	57.1	10.9		
		20	29.1	4.83	34.7	5.79	40.3	7.04	43.1	7.7	45.9	8.4	51.5	10.0	57.1	11.6		
		21	29.1	4.87	34.7	5.96	40.3	7.3	43.1	8.0	45.9	8.7	51.5	10.4	57.1	11.9		
		23	29.1	5.09	34.7	6.37	40.3	7.8	43.1	8.6	45.9	9.4	51.5	11.1	57.1	12.4		
		25	29.1	5.43	34.7	6.80	40.3	8.3	43.1	9.2	45.9	10.0	51.5	11.9	57.1	13.0		
		27	29.1	5.78	34.7	7.25	40.3	8.9	43.1	9.8	45.9	10.7	51.5	12.7	56.4	13.5		
		29	29.1	6.14	34.7	7.7	40.3	9.5	43.1	10.4	45.9	11.4	51.5	13.6	55.6	14.1		
		31	29.1	6.53	34.7	8.2	40.3	10.1	43.1	11.1	45.9	12.2	51.5	14.5	54.8	14.7		
		33	29.1	6.93	34.7	8.7	40.3	10.8	43.1	11.9	45.9	13.0	51.5	15.1	54.0	15.2		
		35	29.1	7.36	34.7	9.3	40.3	11.5	43.1	12.6	45.9	13.9	51.5	15.6	53.2	15.8		
		37	29.1	7.8	34.7	9.9	40.3	12.2	43.1	13.5	45.9	14.8	51.1	16.2	52.4	16.3		
		39	29.1	8.3	34.7	10.5	40.3	13.0	43.1	14.3	45.9	15.8	50.3	16.7	51.6	16.9		
100	450 (49.00)	10	26.5	4.05	31.6	4.82	36.7	5.62	39.2	6.02	41.7	6.44	46.8	7.3	51.9	8.1		
		12	26.5	4.12	31.6	4.90	36.7	5.71	39.2	6.13	41.7	6.55	46.8	7.4	51.9	8.3		
		14	26.5	4.18	31.6	4.98	36.7	5.81	39.2	6.23	41.7	6.66	46.8	7.5	51.9	8.4		
		16	26.5	4.25	31.6	5.06	36.7	5.91	39.2	6.35	41.7	6.78	46.8	7.7	51.9	8.7		
		18	26.5	4.32	31.6	5.15	36.7	6.02	39.2	6.46	41.7	6.91	46.8	8.1	51.9	9.4		
		20	26.5	4.39	31.6	5.24	36.7	6.19	39.2	6.77	41.7	7.4	46.8	8.7	51.9	10.1		
		21	26.5	4.43	31.6	5.29	36.7	6.40	39.2	7.01	41.7	7.6	46.8	9.0	51.9	10.5		
		23	26.5	4.54	31.6	5.63	36.7	6.85	39.2	7.5	41.7	8.2	46.8	9.6	51.9	11.2		
		25	26.5	4.83	31.6	6.01	36.7	7.31	39.2	8.0	41.7	8.7	46.8	10.3	51.9	12.0		
		27	26.5	5.14	31.6	6.40	36.7	7.8	39.2	8.6	41.7	9.3	46.8	11.0	51.9	12.9		
		29	26.5	5.46	31.6	6.81	36.7	8.3	39.2	9.1	41.7	10.0	46.8	11.8	51.9	13.8		
		31	26.5	5.80	31.6	7.24	36.7	8.9	39.2	9.7	41.7	10.6	46.8	12.6	51.9	14.5		
		33	26.5	6.16	31.6	7.7	36.7	9.4	39.2	10.4	41.7	11.3	46.8	13.4	51.9	15.1		
		35	26.5	6.53	31.6	8.2	36.7	10.0	39.2	11.0	41.7	12.1	46.8	14.3	51.9	15.6		
		37	26.5	6.92	31.6	8.7	36.7	10.7	39.2	11.7	41.7	12.8	46.8	15.2	51.2	16.2		
		39	26.5	7.33	31.6	9.2	36.7	11.3	39.2	12.5	41.7	13.7	46.8	16.2	50.4	16.8		

4TW33912-3A(5)

4 Capacity tables

4 - 1 Cooling Capacity Tables

RXYRQ18P - Correction factor for mixed connection: 0.8

TC: Total Capacity: kW ; PI: Power Input: kW (compressor + outdoor fan motor)

Combination (%)	Capacity index (kW)	Outdoor air temp. °CDB	Indoor air temperature:													
			14.0 °CWB		16.0 °CWB		18.0 °CWB		19.0 °CWB		20.0 °CWB		22.0 °CWB		24.0 °CWB	
			20.0 °CDB		23.0 °CDB		16.0 °CDB		27.0 °CDB		28.0 °CDB		30.0 °CDB		32.0 °CDB	
			TC	PI	TC	PI	TC	PI	TC	PI	TC	PI	TC	PI	TC	PI
90	405 (44.10)	10	23.8	3.67	28.4	4.34	33.0	5.04	35.3	5.40	37.6	5.76	42.2	6.51	46.8	7.3
		12	23.8	3.73	28.4	4.41	33.0	5.12	35.3	5.49	37.6	5.86	42.2	6.62	46.8	7.4
		14	23.8	3.79	28.4	4.48	33.0	5.21	35.3	5.58	37.6	5.96	42.2	6.73	46.8	7.5
		16	23.8	3.84	28.4	4.56	33.0	5.30	35.3	5.68	37.6	6.07	42.2	6.85	46.8	7.7
		18	23.8	3.91	28.4	4.63	33.0	5.39	35.3	5.78	37.6	6.18	42.2	6.98	46.8	8.1
		20	23.8	3.97	28.4	4.71	33.0	5.49	35.3	5.89	37.6	6.40	42.2	7.5	46.8	8.7
		21	23.8	4.00	28.4	4.75	33.0	5.58	35.3	6.09	37.6	6.62	42.2	7.8	46.8	9.0
		23	23.8	4.07	28.4	4.94	33.0	5.96	35.3	6.51	37.6	7.08	42.2	8.3	46.8	9.6
		25	23.8	4.28	28.4	5.26	33.0	6.36	35.3	6.95	37.6	7.6	42.2	8.9	46.8	10.3
		27	23.8	4.55	28.4	5.60	33.0	6.78	35.3	7.4	37.6	8.1	42.2	9.5	46.8	11.0
		29	23.8	4.83	28.4	5.96	33.0	7.22	35.3	7.9	37.6	8.6	42.2	10.1	46.8	11.7
		31	23.8	5.12	28.4	6.33	33.0	7.7	35.3	8.4	37.6	9.2	42.2	10.8	46.8	12.5
		33	23.8	5.43	28.4	6.72	33.0	8.2	35.3	8.9	37.6	9.8	42.2	11.5	46.8	13.4
		35	23.8	5.75	28.4	7.14	33.0	8.7	35.3	9.5	37.6	10.4	42.2	12.2	46.8	14.3
		37	23.8	6.09	28.4	7.6	33.0	9.2	35.3	10.1	37.6	11.0	42.2	13.0	46.8	15.2
		39	23.8	6.44	28.4	8.0	33.0	9.8	35.3	10.7	37.6	11.7	42.2	13.9	46.8	16.2
		80	360 (39.20)	10	21.2	3.31	25.2	3.88	29.3	4.48	31.4	4.79	33.4	5.10	37.5	5.75
12	21.2			3.35	25.2	3.94	29.3	4.55	31.4	4.87	33.4	5.19	37.5	5.85	41.6	6.52
14	21.2			3.40	25.2	4.00	29.3	4.62	31.4	4.95	33.4	5.28	37.5	5.95	41.6	6.63
16	21.2			3.45	25.2	4.06	29.3	4.70	31.4	5.03	33.4	5.37	37.5	6.05	41.6	6.75
18	21.2			3.51	25.2	4.13	29.3	4.78	31.4	5.12	33.4	5.46	37.5	6.16	41.6	6.87
20	21.2			3.56	25.2	4.20	29.3	4.87	31.4	5.21	33.4	5.56	37.5	6.38	41.6	7.3
21	21.2			3.59	25.2	4.23	29.3	4.91	31.4	5.26	33.4	5.67	37.5	6.60	41.6	7.6
23	21.2			3.65	25.2	4.31	29.3	5.14	31.4	5.59	33.4	6.06	37.5	7.05	41.6	8.1
25	21.2			3.76	25.2	4.57	29.3	5.48	31.4	5.96	33.4	6.46	37.5	7.5	41.6	8.7
27	21.2			3.99	25.2	4.86	29.3	5.83	31.4	6.35	33.4	6.89	37.5	8.0	41.6	9.3
29	21.2			4.23	25.2	5.17	29.3	6.20	31.4	6.76	33.4	7.34	37.5	8.6	41.6	9.9
31	21.2			4.48	25.2	5.48	29.3	6.59	31.4	7.19	33.4	7.8	37.5	9.1	41.6	10.6
33	21.2			4.74	25.2	5.82	29.3	7.00	31.4	7.6	33.4	8.3	37.5	9.7	41.6	11.3
35	21.2			5.02	25.2	6.16	29.3	7.4	31.4	8.1	33.4	8.8	37.5	10.3	41.6	12.0
37	21.2			5.31	25.2	6.53	29.3	7.9	31.4	8.6	33.4	9.4	37.5	11.0	41.6	12.8
39	21.2			5.61	25.2	6.92	29.3	8.4	31.4	9.1	33.4	10.0	37.5	11.7	41.6	13.6

4TW33912-3A(6)

NOTES - ANMERKUNGEN - Σημειώσεις - NOTAS - REMARQUES - NOTE - OPMERKINGEN - Примечания - NOTLAR

- The above table shows the average value of conditions which may occur.
Die obige Tabelle zeigt den Durchschnittswert der Bedingungen, die auftreten können.
Στον παραπάνω πίνακα αναγράφεται η μέση τιμή για συνθήκες που μπορεί να προκύψουν.
La tabla de arriba muestra el valor medio de condiciones que pueden ocurrir.
Le tableau ci-dessus donne la valeur moyenne pour des conditions qui peuvent survenir.
La tabella in alto mostra il valore delle condizioni medie che si possono riscontrare.
De tabel hierboven geeft de gemiddelde waarde aan van situaties die kunnen voorvallen.
Таблица расположенная выше показывает среднее значение условий, которые могут наступить.
Yukarıdaki tablo meydana gelebilecek koşulların ortalama değerini göstermektedir.
- Correction factor for mixed connection: 0.8. For more information refer to the selection procedure.
Korrekturfaktoren für gemischten Anschluss: 0,8. Weitere Informationen finden Sie im Auswahlverfahren.
Συντελεστής διόρθωσης για συνδυαζόμενη σύνδεση: 0,8. Για περισσότερες πληροφορίες ανατρέξτε στη διαδικασία επιλογής.
Factor de corrección para conexión combinada: 0,8. Si desea más información, consulte el procedimiento de selección.
Facteur de correction pour connexion d'unités mixtes : 0,8. Pour plus d'informations, se reporter à la procédure de sélection.
Fattore di correzione per collegamento varie unità: 0,8. Per maggiori informazioni fare riferimento alla procedura di selezione.
Correctiefactor voor gemengde aansluiting: 0,8. Zie selectieprocedure voor meer informatie.
Поправочный коэффициент для комбинированного соединения: 0,8. Подробная информация приводится в разделе порядка выбора.
Karışık bağlantı için düzeltme faktörü: 0.8. Daha fazla bilgi için, seçim prosedürüne bakın.

4 Capacity tables

4 - 1 Cooling Capacity Tables

RXYRQ18P - Correction factor for mixed connection: 0.7																		
TC: Total Capacity: kW ; PI: Power Input: kW (compressor + outdoor fan motor)																		
Combination (%)	Capacity index (kW)	Outdoor air temp. °CDB	Indoor air temperature:															
			14.0 °CWB		16.0 °CWB		18.0 °CWB		19.0 °CWB		20.0 °CWB		22.0 °CWB		24.0 °CWB			
			20.0 °CDB		23.0 °CDB		16.0 °CDB		27.0 °CDB		28.0 °CDB		30.0 °CDB		32.0 °CDB			
			TC	PI	TC	PI	TC	PI	TC	PI	TC	PI	TC	PI	TC	PI		
130	585 (63.70)	10	30.1	4.47	35.9	5.31	41.7	6.2	44.6	6.6	47.5	7.0	53.3	7.86	59.1	8.67		
		12	30.1	4.54	35.9	5.39	41.7	6.3	44.6	6.7	47.5	7.1	53.3	7.98	59.1	9.08		
		14	30.1	4.61	35.9	5.48	41.7	6.4	44.6	6.8	47.5	7.2	53.3	8.4	59.1	9.8		
		16	30.1	4.68	35.9	5.57	41.7	6.5	44.6	7.0	47.5	7.7	53.3	9.1	59.1	10.6		
		18	30.1	4.76	35.9	5.67	41.7	6.9	44.6	7.5	47.5	8.3	53.3	9.8	59.1	11.3		
		20	30.1	4.84	35.9	6.02	41.7	7.4	44.6	8.1	47.5	8.9	53.3	10.5	59.1	11.8		
		21	30.1	4.97	35.9	6.2	41.7	7.6	44.6	8.4	47.5	9.2	53.3	10.9	59.1	12.1		
		23	30.1	5.31	35.9	6.7	41.7	8.2	44.6	9.0	47.5	9.8	53.3	11.7	59.1	12.6		
		25	30.1	5.66	35.9	7.1	41.7	8.7	44.6	9.6	47.5	10.5	53.3	12.5	59.1	13.2		
		27	30.1	6.02	35.9	7.6	41.7	9.3	44.6	10.3	47.5	11.3	53.3	13.4	58.8	13.8		
		29	30.1	6.4	35.9	8.1	41.7	10.0	44.6	11.0	47.5	12.0	53.3	14.2	58.0	14.3		
		31	30.1	6.8	35.9	8.6	41.7	10.6	44.6	11.7	47.5	12.8	53.3	14.7	57.2	14.9		
		33	30.1	7.2	35.9	9.2	41.7	11.3	44.6	12.5	47.5	13.7	53.3	15.3	56.4	15.5		
		35	30.1	7.7	35.9	9.7	41.7	12.0	44.6	13.3	47.5	14.6	53.3	15.9	55.6	16.1		
		37	30.1	8.2	35.9	10.4	41.7	12.8	44.6	14.2	47.5	15.6	53.3	16.4	54.8	16.6		
		39	30.1	8.7	35.9	11.0	41.7	13.6	44.6	15.1	47.5	16.6	52.5	17.0	54.0	17.2		
		120	540 (58.80)	10	27.8	4.14	33.1	4.90	38.5	5.69	41.2	6.1	43.8	6.5	49.2	7.3	54.5	8.04
				12	27.8	4.20	33.1	4.98	38.5	5.78	41.2	6.2	43.8	6.6	49.2	7.4	54.5	8.16
14	27.8			4.27	33.1	5.06	38.5	5.88	41.2	6.3	43.8	6.7	49.2	7.5	54.5	8.7		
16	27.8			4.34	33.1	5.15	38.5	5.97	41.2	6.4	43.8	6.9	49.2	8.1	54.5	9.4		
18	27.8			4.41	33.1	5.23	38.5	6.2	41.2	6.8	43.8	7.4	49.2	8.7	54.5	10.1		
20	27.8			4.48	33.1	5.43	38.5	6.6	41.2	7.2	43.8	7.9	49.2	9.3	54.5	10.9		
21	27.8			4.52	33.1	5.61	38.5	6.8	41.2	7.5	43.8	8.2	49.2	9.7	54.5	11.3		
23	27.8			4.81	33.1	5.99	38.5	7.3	41.2	8.0	43.8	8.8	49.2	10.4	54.5	12.1		
25	27.8			5.13	33.1	6.4	38.5	7.8	41.2	8.6	43.8	9.4	49.2	11.1	54.5	12.9		
27	27.8			5.45	33.1	6.8	38.5	8.3	41.2	9.2	43.8	10.0	49.2	11.9	54.5	13.7		
29	27.8			5.80	33.1	7.3	38.5	8.9	41.2	9.8	43.8	10.7	49.2	12.7	54.5	14.2		
31	27.8			6.16	33.1	7.7	38.5	9.5	41.2	10.4	43.8	11.4	49.2	13.5	54.5	14.8		
33	27.8			6.5	33.1	8.2	38.5	10.1	41.2	11.1	43.8	12.2	49.2	14.4	54.5	15.3		
35	27.8			6.9	33.1	8.7	38.5	10.7	41.2	11.8	43.8	13.0	49.2	15.4	54.4	15.9		
37	27.8			7.4	33.1	9.3	38.5	11.4	41.2	12.6	43.8	13.8	49.2	16.3	53.6	16.5		
39	27.8			7.8	33.1	9.9	38.5	12.1	41.2	13.4	43.8	14.7	49.2	16.9	52.8	17.1		
110	495 (53.90)			10	25.5	3.82	30.4	4.51	35.3	5.22	37.7	5.58	40.2	5.94	45.1	6.7	50.0	7.4
				12	25.5	3.88	30.4	4.58	35.3	5.30	37.7	5.67	40.2	6.0	45.1	6.8	50.0	7.5
		14	25.5	3.94	30.4	4.65	35.3	5.39	37.7	5.76	40.2	6.1	45.1	6.9	50.0	7.7		
		16	25.5	4.00	30.4	4.73	35.3	5.48	37.7	5.86	40.2	6.2	45.1	7.1	50.0	8.3		
		18	25.5	4.06	30.4	4.80	35.3	5.57	37.7	6.00	40.2	6.5	45.1	7.7	50.0	8.9		
		20	25.5	4.13	30.4	4.89	35.3	5.88	37.7	6.4	40.2	7.0	45.1	8.2	50.0	9.6		
		21	25.5	4.16	30.4	5.03	35.3	6.1	37.7	6.7	40.2	7.3	45.1	8.5	50.0	9.9		
		23	25.5	4.34	30.4	5.37	35.3	6.5	37.7	7.1	40.2	7.8	45.1	9.1	50.0	10.6		
		25	25.5	4.62	30.4	5.72	35.3	6.9	37.7	7.6	40.2	8.3	45.1	9.8	50.0	11.4		
		27	25.5	4.91	30.4	6.09	35.3	7.4	37.7	8.1	40.2	8.9	45.1	10.4	50.0	12.1		
		29	25.5	5.22	30.4	6.5	35.3	7.9	37.7	8.7	40.2	9.4	45.1	11.1	50.0	13.0		
		31	25.5	5.54	30.4	6.9	35.3	8.4	37.7	9.2	40.2	10.1	45.1	11.9	50.0	13.9		
		33	25.5	5.88	30.4	7.3	35.3	8.9	37.7	9.8	40.2	10.7	45.1	12.7	50.0	14.8		
		35	25.5	6.23	30.4	7.8	35.3	9.5	37.7	10.4	40.2	11.4	45.1	13.5	50.0	15.8		
		37	25.5	6.6	30.4	8.3	35.3	10.1	37.7	11.1	40.2	12.2	45.1	14.4	50.0	16.3		
		39	25.5	7.0	30.4	8.8	35.3	10.7	37.7	11.8	40.2	12.9	45.1	15.3	50.0	16.9		
		100	450 (49.00)	10	23.1	3.51	27.6	4.12	32.1	4.75	34.3	5.07	36.5	5.40	41.0	6.1	45.5	6.7
				12	23.1	3.56	27.6	4.18	32.1	4.83	34.3	5.15	36.5	5.49	41.0	6.2	45.5	6.8
14	23.1			3.61	27.6	4.24	32.1	4.90	34.3	5.24	36.5	5.58	41.0	6.3	45.5	6.9		
16	23.1			3.66	27.6	4.31	32.1	4.98	34.3	5.33	36.5	5.67	41.0	6.4	45.5	7.2		
18	23.1			3.72	27.6	4.38	32.1	5.07	34.3	5.42	36.5	5.77	41.0	6.7	45.5	7.8		
20	23.1			3.78	27.6	4.46	32.1	5.21	34.3	5.67	36.5	6.2	41.0	7.2	45.5	8.3		
21	23.1			3.81	27.6	4.49	32.1	5.38	34.3	5.87	36.5	6.4	41.0	7.5	45.5	8.6		
23	23.1			3.90	27.6	4.78	32.1	5.75	34.3	6.3	36.5	6.8	41.0	8.0	45.5	9.2		
25	23.1			4.14	27.6	5.09	32.1	6.13	34.3	6.7	36.5	7.3	41.0	8.5	45.5	9.9		
27	23.1			4.40	27.6	5.41	32.1	6.5	34.3	7.1	36.5	7.8	41.0	9.1	45.5	10.6		
29	23.1			4.67	27.6	5.76	32.1	7.0	34.3	7.6	36.5	8.3	41.0	9.7	45.5	11.3		
31	23.1			4.96	27.6	6.11	32.1	7.4	34.3	8.1	36.5	8.8	41.0	10.4	45.5	12.0		
33	23.1			5.25	27.6	6.5	32.1	7.9	34.3	8.6	36.5	9.4	41.0	11.0	45.5	12.8		
35	23.1			5.56	27.6	6.9	32.1	8.4	34.3	9.2	36.5	10.0	41.0	11.7	45.5	13.7		
37	23.1			5.89	27.6	7.3	32.1	8.9	34.3	9.7	36.5	10.6	41.0	12.5	45.5	14.6		
39	23.1			6.23	27.6	7.7	32.1	9.4	34.3	10.3	36.5	11.3	41.0	13.3	45.5	15.5		

4TW33912-3A(7)

4 Capacity tables

4 - 1 Cooling Capacity Tables

RXYRQ18P - Correction factor for mixed connection: 0.7

TC: Total Capacity: kW ; PI: Power Input: kW (compressor + outdoor fan motor)

Combination (%)	Capacity index (kW)	Outdoor air temp. °CDB	Indoor air temperature:													
			14.0 °CWB		16.0 °CWB		18.0 °CWB		19.0 °CWB		20.0 °CWB		22.0 °CWB		24.0 °CWB	
			20.0 °CDB		23.0 °CDB		16.0 °CDB		27.0 °CDB		28.0 °CDB		30.0 °CDB		32.0 °CDB	
			TC	PI	TC	PI	TC	PI	TC	PI	TC	PI	TC	PI	TC	PI
90	405 (44.10)	10	20.8	3.20	24.8	3.74	28.9	4.29	30.9	4.58	32.9	4.87	36.9	5.45	40.9	6.0
		12	20.8	3.25	24.8	3.79	28.9	4.36	30.9	4.65	32.9	4.94	36.9	5.54	40.9	6.1
		14	20.8	3.29	24.8	3.85	28.9	4.43	30.9	4.72	32.9	5.02	36.9	5.63	40.9	6.2
		16	20.8	3.34	24.8	3.91	28.9	4.50	30.9	4.80	32.9	5.11	36.9	5.73	40.9	6.4
		18	20.8	3.39	24.8	3.97	28.9	4.57	30.9	4.88	32.9	5.19	36.9	5.83	40.9	6.7
		20	20.8	3.44	24.8	4.03	28.9	4.65	30.9	4.97	32.9	5.37	36.9	6.2	40.9	7.2
		21	20.8	3.47	24.8	4.07	28.9	4.72	30.9	5.13	32.9	5.56	36.9	6.5	40.9	7.4
		23	20.8	3.52	24.8	4.22	28.9	5.04	30.9	5.48	32.9	5.93	36.9	6.9	40.9	8.0
		25	20.8	3.70	24.8	4.49	28.9	5.37	30.9	5.84	32.9	6.3	36.9	7.4	40.9	8.5
		27	20.8	3.92	24.8	4.78	28.9	5.72	30.9	6.2	32.9	6.7	36.9	7.9	40.9	9.1
		29	20.8	4.16	24.8	5.07	28.9	6.08	30.9	6.6	32.9	7.2	36.9	8.4	40.9	9.7
		31	20.8	4.40	24.8	5.38	28.9	6.5	30.9	7.0	32.9	7.6	36.9	8.9	40.9	10.3
		33	20.8	4.66	24.8	5.71	28.9	6.9	30.9	7.5	32.9	8.1	36.9	9.5	40.9	11.0
35	20.8	4.93	24.8	6.05	28.9	7.3	30.9	7.9	32.9	8.6	36.9	10.1	40.9	11.7		
37	20.8	5.22	24.8	6.4	28.9	7.7	30.9	8.4	32.9	9.2	36.9	10.8	40.9	12.5		
39	20.8	5.51	24.8	6.8	28.9	8.2	30.9	9.0	32.9	9.7	36.9	11.4	40.9	13.3		
80	360 (39.20)	10	18.5	2.91	22.1	3.37	25.7	3.85	27.4	4.09	29.2	4.34	32.8	4.85	36.4	5.37
		12	18.5	2.95	22.1	3.41	25.7	3.90	27.4	4.16	29.2	4.41	32.8	4.93	36.4	5.46
		14	18.5	2.98	22.1	3.46	25.7	3.96	27.4	4.22	29.2	4.48	32.8	5.01	36.4	5.55
		16	18.5	3.03	22.1	3.51	25.7	4.03	27.4	4.29	29.2	4.55	32.8	5.09	36.4	5.64
		18	18.5	3.07	22.1	3.57	25.7	4.09	27.4	4.36	29.2	4.63	32.8	5.18	36.4	5.74
		20	18.5	3.11	22.1	3.62	25.7	4.16	27.4	4.43	29.2	4.71	32.8	5.35	36.4	6.1
		21	18.5	3.13	22.1	3.65	25.7	4.19	27.4	4.47	29.2	4.80	32.8	5.54	36.4	6.3
		23	18.5	3.18	22.1	3.71	25.7	4.38	27.4	4.74	29.2	5.12	32.8	5.92	36.4	6.8
		25	18.5	3.27	22.1	3.94	25.7	4.66	27.4	5.05	29.2	5.45	32.8	6.3	36.4	7.2
		27	18.5	3.47	22.1	4.18	25.7	4.96	27.4	5.37	29.2	5.81	32.8	6.7	36.4	7.7
		29	18.5	3.68	22.1	4.43	25.7	5.27	27.4	5.71	29.2	6.18	32.8	7.2	36.4	8.2
		31	18.5	3.89	22.1	4.70	25.7	5.59	27.4	6.07	29.2	6.6	32.8	7.6	36.4	8.8
		33	18.5	4.11	22.1	4.98	25.7	5.93	27.4	6.4	29.2	7.0	32.8	8.1	36.4	9.3
35	18.5	4.34	22.1	5.27	25.7	6.3	27.4	6.8	29.2	7.4	32.8	8.6	36.4	9.9		
37	18.5	4.59	22.1	5.57	25.7	6.7	27.4	7.2	29.2	7.9	32.8	9.1	36.4	10.5		
39	18.5	4.84	22.1	5.89	25.7	7.1	27.4	7.7	29.2	8.3	32.8	9.7	36.4	11.2		

4TW33912-3A(8)

NOTES - ANMERKUNGEN - Σημειώσεις - NOTAS - REMARQUES - NOTE - OPMERKINGEN - Примечания - NOTLAR

- The above table shows the average value of conditions which may occur.
Die obige Tabelle zeigt den Durchschnittswert der Bedingungen, die auftreten können.
 Στον παραπάνω πίνακα αναγράφεται η μέση τιμή για συνθήκες που μπορεί να προκύψουν.
La tabla de arriba muestra el valor medio de condiciones que pueden ocurrir.
 Le tableau ci-dessus donne la valeur moyenne pour des conditions qui peuvent survenir.
La tabella in alto mostra il valore delle condizioni medie che si possono riscontrare.
 De tabel hierboven geeft de gemiddelde waarde aan van situaties die kunnen voorvallen.
Таблица расположенная выше показывает среднее значение условий, которые могут наступить.
 Yukarıdaki tablo meydana gelebilecek koşulların ortalama değerini göstermektedir.
- Correction factor for mixed connection: 0.7. For more information refer to the selection procedure.
Korrekturfaktoren für gemischten Anschluss: 0,7. Weitere Informationen finden Sie im Auswahlverfahren.
 Συντελεστής διόρθωσης για συνδυαζόμενη σύνδεση: 0,7. Για περισσότερες πληροφορίες ανατρέξτε στη διαδικασία επιλογής.
Factor de corrección para conexión combinada: 0,7. Si desea más información, consulte el procedimiento de selección.
 Facteur de correction pour connexion d'unités mixtes : 0,7. Pour plus d'informations, se reporter à la procédure de sélection.
Fattore di correzione per collegamento varie unità: 0,7. Per maggiori informazioni fare riferimento alla procedura di selezione.
 Correctiefactor voor gemengde aansluiting: 0,7. Zie selectieprocedure voor meer informatie.
Поправочный коэффициент для комбинированного соединения: 0,7. Подробная информация приводится в разделе порядка выбора.
 Karışık bağlantı için düzeltme faktörü: 0.7. Daha fazla bilgi için, seçim prosedürüne bakın.

4 Capacity tables

4 - 1 Cooling Capacity Tables

RXYRQ18P - Correction factor for mixed connection: 0.6

TC: Total Capacity: kW ; PI: Power Input: kW (compressor + outdoor fan motor)

Combination (%)	Capacity index (kW)	Outdoor air temp. °CDB	Indoor air temperature:															
			14.0 °CWB		16.0 °CWB		18.0 °CWB		19.0 °CWB		20.0 °CWB		22.0 °CWB		24.0 °CWB			
			20.0 °CDB		23.0 °CDB		16.0 °CDB		27.0 °CDB		28.0 °CDB		30.0 °CDB		32.0 °CDB			
			TC	PI	TC	PI	TC	PI	TC	PI	TC	PI	TC	PI	TC	PI		
130	585 (63.70)	10	25.8	3.74	30.8	4.38	35.7	5.0	38.2	5.4	40.7	5.7	45.7	6.31	50.6	6.91		
		12	25.8	3.80	30.8	4.45	35.7	5.1	38.2	5.4	40.7	5.8	45.7	6.40	50.6	7.23		
		14	25.8	3.85	30.8	4.52	35.7	5.2	38.2	5.5	40.7	5.9	45.7	6.7	50.6	7.8		
		16	25.8	3.91	30.8	4.59	35.7	5.3	38.2	5.7	40.7	6.2	45.7	7.3	50.6	8.4		
		18	25.8	3.97	30.8	4.66	35.7	5.6	38.2	6.1	40.7	6.7	45.7	7.8	50.6	9.1		
		20	25.8	4.03	30.8	4.94	35.7	6.0	38.2	6.5	40.7	7.1	45.7	8.4	50.6	9.7		
		21	25.8	4.13	30.8	5.1	35.7	6.2	38.2	6.8	40.7	7.4	45.7	8.7	50.6	10.1		
		23	25.8	4.41	30.8	5.5	35.7	6.6	38.2	7.2	40.7	7.9	45.7	9.3	50.6	10.8		
		25	25.8	4.69	30.8	5.8	35.7	7.1	38.2	7.7	40.7	8.4	45.7	9.9	50.6	11.6		
		27	25.8	4.99	30.8	6.2	35.7	7.5	38.2	8.3	40.7	9.0	45.7	10.6	50.6	12.4		
		29	25.8	5.3	30.8	6.6	35.7	8.0	38.2	8.8	40.7	9.6	45.7	11.4	50.6	13.2		
		31	25.8	5.6	30.8	7.0	35.7	8.6	38.2	9.4	40.7	10.3	45.7	12.1	50.6	14.1		
		33	25.8	6.0	30.8	7.4	35.7	9.1	38.2	10.0	40.7	10.9	45.7	12.9	50.6	15.1		
		35	25.8	6.3	30.8	7.9	35.7	9.7	38.2	10.6	40.7	11.6	45.7	13.8	50.6	16.1		
		37	25.8	6.7	30.8	8.4	35.7	10.3	38.2	11.3	40.7	12.4	45.7	14.7	50.6	16.6		
		39	25.8	7.1	30.8	8.9	35.7	10.9	38.2	12.0	40.7	13.2	45.7	15.6	50.6	17.2		
		120	540 (58.80)	10	23.8	3.49	28.4	4.08	33.0	4.67	35.3	5.0	37.6	5.3	42.2	5.9	46.8	6.44
12	23.8			3.54	28.4	4.14	33.0	4.74	35.3	5.0	37.6	5.4	42.2	6.0	46.8	6.53		
14	23.8			3.59	28.4	4.20	33.0	4.82	35.3	5.1	37.6	5.4	42.2	6.0	46.8	7.0		
16	23.8			3.64	28.4	4.26	33.0	4.89	35.3	5.2	37.6	5.6	42.2	6.5	46.8	7.5		
18	23.8			3.70	28.4	4.33	33.0	5.0	35.3	5.5	37.6	6.0	42.2	7.0	46.8	8.1		
20	23.8			3.75	28.4	4.48	33.0	5.4	35.3	5.9	37.6	6.4	42.2	7.5	46.8	8.7		
21	23.8			3.78	28.4	4.63	33.0	5.6	35.3	6.1	37.6	6.6	42.2	7.8	46.8	9.0		
23	23.8			4.02	28.4	4.94	33.0	6.0	35.3	6.5	37.6	7.1	42.2	8.3	46.8	9.6		
25	23.8			4.28	28.4	5.3	33.0	6.4	35.3	6.9	37.6	7.6	42.2	8.9	46.8	10.3		
27	23.8			4.55	28.4	5.6	33.0	6.8	35.3	7.4	37.6	8.1	42.2	9.5	46.8	11.0		
29	23.8			4.83	28.4	6.0	33.0	7.2	35.3	7.9	37.6	8.6	42.2	10.1	46.8	11.7		
31	23.8			5.12	28.4	6.3	33.0	7.7	35.3	8.4	37.6	9.2	42.2	10.8	46.8	12.5		
33	23.8			5.4	28.4	6.7	33.0	8.2	35.3	8.9	37.6	9.8	42.2	11.5	46.8	13.4		
35	23.8			5.7	28.4	7.1	33.0	8.7	35.3	9.5	37.6	10.4	42.2	12.2	46.8	14.3		
37	23.8			6.1	28.4	7.6	33.0	9.2	35.3	10.1	37.6	11.0	42.2	13.0	46.8	15.2		
39	23.8			6.4	28.4	8.0	33.0	9.8	35.3	10.7	37.6	11.7	42.2	13.9	46.8	16.2		
110	495 (53.90)			10	21.8	3.25	26.0	3.77	30.2	4.32	32.3	4.59	34.4	4.86	38.6	5.4	42.9	6.0
		12	21.8	3.29	26.0	3.83	30.2	4.38	32.3	4.66	34.4	4.9	38.6	5.5	42.9	6.0		
		14	21.8	3.33	26.0	3.88	30.2	4.45	32.3	4.73	34.4	5.0	38.6	5.6	42.9	6.2		
		16	21.8	3.38	26.0	3.94	30.2	4.51	32.3	4.80	34.4	5.1	38.6	5.8	42.9	6.6		
		18	21.8	3.43	26.0	4.00	30.2	4.58	32.3	4.91	34.4	5.3	38.6	6.2	42.9	7.1		
		20	21.8	3.48	26.0	4.06	30.2	4.84	32.3	5.3	34.4	5.7	38.6	6.6	42.9	7.7		
		21	21.8	3.51	26.0	4.18	30.2	5.0	32.3	5.4	34.4	5.9	38.6	6.9	42.9	7.9		
		23	21.8	3.66	26.0	4.45	30.2	5.3	32.3	5.8	34.4	6.3	38.6	7.4	42.9	8.5		
		25	21.8	3.88	26.0	4.74	30.2	5.7	32.3	6.2	34.4	6.7	38.6	7.9	42.9	9.1		
		27	21.8	4.12	26.0	5.04	30.2	6.1	32.3	6.6	34.4	7.2	38.6	8.4	42.9	9.7		
		29	21.8	4.37	26.0	5.4	30.2	6.4	32.3	7.0	34.4	7.6	38.6	8.9	42.9	10.4		
		31	21.8	4.64	26.0	5.7	30.2	6.9	32.3	7.5	34.4	8.1	38.6	9.5	42.9	11.0		
		33	21.8	4.91	26.0	6.0	30.2	7.3	32.3	8.0	34.4	8.7	38.6	10.1	42.9	11.8		
		35	21.8	5.20	26.0	6.4	30.2	7.7	32.3	8.5	34.4	9.2	38.6	10.8	42.9	12.5		
		37	21.8	5.5	26.0	6.8	30.2	8.2	32.3	9.0	34.4	9.8	38.6	11.5	42.9	13.3		
		39	21.8	5.8	26.0	7.2	30.2	8.7	32.3	9.5	34.4	10.4	38.6	12.2	42.9	14.2		
		100	450 (49.00)	10	19.8	3.00	23.7	3.47	27.5	3.96	29.4	4.21	31.3	4.46	35.1	5.0	39.0	5.5
12	19.8			3.04	23.7	3.52	27.5	4.02	29.4	4.27	31.3	4.52	35.1	5.0	39.0	5.5		
14	19.8			3.08	23.7	3.57	27.5	4.08	29.4	4.33	31.3	4.59	35.1	5.1	39.0	5.6		
16	19.8			3.12	23.7	3.62	27.5	4.14	29.4	4.40	31.3	4.66	35.1	5.2	39.0	5.8		
18	19.8			3.17	23.7	3.68	27.5	4.20	29.4	4.47	31.3	4.73	35.1	5.5	39.0	6.3		
20	19.8			3.21	23.7	3.73	27.5	4.31	29.4	4.67	31.3	5.1	35.1	5.9	39.0	6.7		
21	19.8			3.24	23.7	3.76	27.5	4.45	29.4	4.83	31.3	5.2	35.1	6.1	39.0	7.0		
23	19.8			3.31	23.7	3.99	27.5	4.75	29.4	5.2	31.3	5.6	35.1	6.5	39.0	7.4		
25	19.8			3.51	23.7	4.25	27.5	5.06	29.4	5.5	31.3	5.9	35.1	6.9	39.0	7.9		
27	19.8			3.72	23.7	4.51	27.5	5.4	29.4	5.9	31.3	6.3	35.1	7.4	39.0	8.5		
29	19.8			3.95	23.7	4.79	27.5	5.7	29.4	6.2	31.3	6.7	35.1	7.9	39.0	9.0		
31	19.8			4.18	23.7	5.08	27.5	6.1	29.4	6.6	31.3	7.2	35.1	8.4	39.0	9.6		
33	19.8			4.42	23.7	5.4	27.5	6.5	29.4	7.0	31.3	7.6	35.1	8.9	39.0	10.3		
35	19.8			4.67	23.7	5.7	27.5	6.8	29.4	7.5	31.3	8.1	35.1	9.5	39.0	10.9		
37	19.8			4.94	23.7	6.0	27.5	7.3	29.4	7.9	31.3	8.6	35.1	10.1	39.0	11.6		
39	19.8			5.22	23.7	6.4	27.5	7.7	29.4	8.4	31.3	9.1	35.1	10.7	39.0	12.4		

4TW33912-3A(9)

4 Capacity tables

4 - 1 Cooling Capacity Tables

RXYRQ18P - Correction factor for mixed connection: 0.6

TC: Total Capacity: kW ; PI: Power Input: kW (compressor + outdoor fan motor)

Combination (%)	Capacity index (kW)	Outdoor air temp. °CDB	Indoor air temperature:															
			14.0 °CWB		16.0 °CWB		18.0 °CWB		19.0 °CWB		20.0 °CWB		22.0 °CWB		24.0 °CWB			
			20.0 °CDB		23.0 °CDB		16.0 °CDB		27.0 °CDB		28.0 °CDB		30.0 °CDB		32.0 °CDB			
			TC	PI	TC	PI	TC	PI	TC	PI	TC	PI	TC	PI	TC	PI		
90	405 (44.10)	10	17.9	2.77	21.3	3.18	24.7	3.61	26.5	3.83	28.2	4.05	31.6	4.50	35.1	4.9		
		12	17.9	2.80	21.3	3.22	24.7	3.66	26.5	3.88	28.2	4.11	31.6	4.56	35.1	5.0		
		14	17.9	2.84	21.3	3.27	24.7	3.71	26.5	3.94	28.2	4.17	31.6	4.63	35.1	5.1		
		16	17.9	2.87	21.3	3.31	24.7	3.77	26.5	4.00	28.2	4.23	31.6	4.70	35.1	5.2		
		18	17.9	2.91	21.3	3.36	24.7	3.82	26.5	4.06	28.2	4.30	31.6	4.78	35.1	5.4		
		20	17.9	2.95	21.3	3.41	24.7	3.88	26.5	4.12	28.2	4.44	31.6	5.1	35.1	5.8		
		21	17.9	2.97	21.3	3.44	24.7	3.94	26.5	4.26	28.2	4.59	31.6	5.3	35.1	6.0		
		23	17.9	3.01	21.3	3.56	24.7	4.20	26.5	4.54	28.2	4.90	31.6	5.6	35.1	6.5		
		25	17.9	3.16	21.3	3.78	24.7	4.47	26.5	4.83	28.2	5.2	31.6	6.0	35.1	6.9		
		27	17.9	3.35	21.3	4.02	24.7	4.75	26.5	5.1	28.2	5.6	31.6	6.4	35.1	7.3		
		29	17.9	3.54	21.3	4.26	24.7	5.05	26.5	5.5	28.2	5.9	31.6	6.8	35.1	7.8		
		31	17.9	3.75	21.3	4.51	24.7	5.4	26.5	5.8	28.2	6.3	31.6	7.3	35.1	8.3		
		33	17.9	3.96	21.3	4.78	24.7	5.7	26.5	6.2	28.2	6.7	31.6	7.7	35.1	8.9		
		35	17.9	4.18	21.3	5.06	24.7	6.0	26.5	6.5	28.2	7.1	31.6	8.2	35.1	9.4		
		37	17.9	4.41	21.3	5.3	24.7	6.4	26.5	6.9	28.2	7.5	31.6	8.7	35.1	10.0		
		39	17.9	4.66	21.3	5.7	24.7	6.7	26.5	7.3	28.2	7.9	31.6	9.2	35.1	10.7		
		80	360 (39.20)	10	15.9	2.54	18.9	2.89	22.0	3.27	23.5	3.46	25.0	3.65	28.1	4.04	31.2	4.44
				12	15.9	2.57	18.9	2.93	22.0	3.31	23.5	3.50	25.0	3.70	28.1	4.10	31.2	4.50
				14	15.9	2.60	18.9	2.97	22.0	3.36	23.5	3.55	25.0	3.75	28.1	4.16	31.2	4.57
16	15.9			2.63	18.9	3.01	22.0	3.40	23.5	3.61	25.0	3.81	28.1	4.22	31.2	4.64		
18	15.9			2.66	18.9	3.05	22.0	3.45	23.5	3.66	25.0	3.87	28.1	4.29	31.2	4.71		
20	15.9			2.70	18.9	3.09	22.0	3.50	23.5	3.71	25.0	3.93	28.1	4.43	31.2	5.0		
21	15.9			2.71	18.9	3.11	22.0	3.53	23.5	3.74	25.0	4.00	28.1	4.57	31.2	5.2		
23	15.9			2.75	18.9	3.16	22.0	3.68	23.5	3.97	25.0	4.26	28.1	4.88	31.2	5.5		
25	15.9			2.83	18.9	3.35	22.0	3.92	23.5	4.22	25.0	4.53	28.1	5.2	31.2	5.9		
27	15.9			2.99	18.9	3.55	22.0	4.16	23.5	4.48	25.0	4.82	28.1	5.5	31.2	6.3		
29	15.9			3.16	18.9	3.76	22.0	4.41	23.5	4.76	25.0	5.12	28.1	5.9	31.2	6.7		
31	15.9			3.34	18.9	3.98	22.0	4.68	23.5	5.05	25.0	5.4	28.1	6.3	31.2	7.1		
33	15.9			3.53	18.9	4.21	22.0	4.95	23.5	5.3	25.0	5.8	28.1	6.6	31.2	7.6		
35	15.9			3.72	18.9	4.45	22.0	5.2	23.5	5.7	25.0	6.1	28.1	7.0	31.2	8.0		
37	15.9			3.92	18.9	4.70	22.0	5.5	23.5	6.0	25.0	6.5	28.1	7.5	31.2	8.5		
39	15.9			4.13	18.9	4.96	22.0	5.9	23.5	6.3	25.0	6.9	28.1	7.9	31.2	9.1		

4TW33912-3A(10)

NOTES - ANMERKUNGEN - Σημειώσεις - NOTAS - REMARQUES - NOTE - OPMERKINGEN - Примечания - NOTLAR

- The above table shows the average value of conditions which may occur.
Die obige Tabelle zeigt den Durchschnittswert der Bedingungen, die auftreten können.
Στον παραπάνω πίνακα αναγράφεται η μέση τιμή για συνθήκες που μπορεί να προκύψουν.
La tabla de arriba muestra el valor medio de condiciones que pueden ocurrir.
Le tableau ci-dessus donne la valeur moyenne pour des conditions qui peuvent survenir.
La tabella in alto mostra il valore delle condizioni medie che si possono riscontrare.
De tabel hierboven geeft de gemiddelde waarde aan van situaties die kunnen voorvallen.
Таблица расположенная выше показывает среднее значение условий, которые могут наступить.
Yukarıdaki tablo meydana gelebilecek koşulların ortalama değerini göstermektedir.
- Correction factor for mixed connection: 0.6. For more information refer to the selection procedure.
Korrekturfaktoren für gemischten Anschluss: 0,6. Weitere Informationen finden Sie im Auswahlverfahren.
Συντελεστής διόρθωσης για συνδυαζόμενη σύνδεση: 0,6. Για περισσότερες πληροφορίες ανατρέξτε στη διαδικασία επιλογής.
Factor de corrección para conexión combinada: 0,6. Si desea más información, consulte el procedimiento de selección.
Facteur de correction pour connexion d'unités mixtes : 0,6. Pour plus d'informations, se reporter à la procédure de sélection.
Fattore di correzione per collegamento varie unità: 0,6. Per maggiori informazioni fare riferimento alla procedura di selezione.
Correctiefactor voor gemengde aansluiting: 0,6. Zie selectieprocedure voor meer informatie.
Поправочный коэффициент для комбинированного соединения: 0,6. Подробная информация приводится в разделе порядка выбора.
Karışık bağlantı için düzeltme faktörü: 0.6. Daha fazla bilgi için, seçim prosedürüne bakın.

4 Capacity tables

4 - 2 Heating Capacity Tables

RXYRQ8P		TC: Total Capacity: kW ; PI: Power Input: kW (compressor + outdoor fan motor)															
Combination (%)	kW (Capacity index)	Outdoor air temp.		Indoor air temp. °CDB													
				16.0		18.0		20.0		21.0		22.0		24.0			
				TC	PI	TC	PI	TC	PI	TC	PI	TC	PI	TC	PI		
		°CDB	°CWB	kW		kW		kW		kW		kW		kW			
90	20.16 (180)	-19.8	-20.0	15.9	5.21	15.9	5.39	15.8	5.58	15.8	5.67	15.8	5.76	15.8	5.85	15.8	5.95
		-18.8	-19.0	16.4	5.31	16.4	5.49	16.3	5.67	16.3	5.76	16.3	5.85	16.2	6.03	16.2	6.03
		-16.7	-17.0	17.4	5.49	17.3	5.66	17.3	5.83	17.3	5.92	17.2	6.00	17.2	6.17	17.2	6.17
		-13.7	-15.0	18.3	5.66	18.3	5.82	18.2	5.98	18.2	6.06	18.2	6.14	18.2	6.30	18.2	6.30
		-11.8	-13.0	19.3	5.81	19.2	5.96	19.2	6.11	19.2	6.19	19.2	6.27	19.1	6.42	19.1	6.42
		-9.8	-11.0	20.2	5.95	20.2	6.09	20.2	6.24	20.1	6.31	20.1	6.38	19.6	6.28	19.6	6.28
		-9.5	-10.0	20.7	6.01	20.7	6.15	20.6	6.29	20.6	6.36	20.6	6.43	19.6	6.10	19.6	6.10
		-8.5	-9.1	21.2	6.06	21.1	6.20	21.1	6.34	21.1	6.41	21.0	6.48	19.6	5.95	19.6	5.95
		-7.0	-7.6	21.9	6.15	21.8	6.28	21.8	6.42	21.8	6.48	21.1	6.22	19.6	5.71	19.6	5.71
		-5.0	-5.6	22.8	6.26	22.8	6.38	22.5	6.39	21.8	6.14	21.1	5.90	19.6	5.41	19.6	5.41
		-3.0	-3.7	23.8	6.35	23.7	6.47	22.5	6.09	21.8	5.85	21.1	5.62	19.6	5.17	19.6	5.17
		0.0	-0.7	25.2	6.49	23.9	6.11	22.5	5.67	21.8	5.45	21.1	5.24	19.6	4.82	19.6	4.82
		3.0	2.2	25.4	6.14	23.9	5.72	22.5	5.31	21.8	5.11	21.1	4.91	19.6	4.53	19.6	4.53
		5.0	4.1	25.4	5.89	23.9	5.49	22.5	5.10	21.8	4.91	21.1	4.72	19.6	4.35	19.6	4.35
		7.0	6.0	25.4	5.66	23.9	5.28	22.5	4.91	21.8	4.73	21.1	4.55	19.6	4.20	19.6	4.20
		9.0	7.9	25.4	5.45	23.9	5.09	22.5	4.73	21.8	4.56	21.1	4.39	19.6	4.05	19.6	4.05
		11.0	9.8	25.4	5.26	23.9	4.91	22.5	4.57	21.8	4.40	21.1	4.24	19.6	3.91	19.6	3.91
		13.0	11.8	25.4	5.07	23.9	4.73	22.5	4.41	21.8	4.25	21.1	4.09	19.6	3.78	19.6	3.78
		15.0	13.7	25.4	4.90	23.9	4.58	22.5	4.27	21.8	4.11	21.1	3.96	19.6	3.66	19.6	3.66
		80	17.92 (160)	-19.8	-20.0	15.8	5.57	15.8	5.73	15.8	5.90	15.8	5.98	15.7	6.06	15.7	6.22
-18.8	-19.0			16.3	5.66	16.3	5.82	16.3	5.98	16.2	6.06	16.2	6.14	16.2	6.30	16.2	6.30
-16.7	-17.0			17.3	5.82	17.2	5.97	17.2	6.12	17.2	6.20	17.2	6.28	17.1	6.43	17.1	6.43
-13.7	-15.0			18.2	5.97	18.2	6.11	18.2	6.26	18.2	6.33	18.1	6.40	17.4	6.16	17.4	6.16
-11.8	-13.0			19.2	6.11	19.2	6.24	19.1	6.38	19.1	6.44	18.7	6.31	17.4	5.78	17.4	5.78
-9.8	-11.0			20.2	6.23	20.1	6.36	20.0	6.44	19.4	6.18	18.7	5.93	17.4	5.45	17.4	5.45
-9.5	-10.0			20.6	6.28	20.6	6.41	20.0	6.25	19.4	6.00	18.7	5.76	17.4	5.29	17.4	5.29
-8.5	-9.1			21.1	6.33	21.0	6.46	20.0	6.09	19.4	5.85	18.7	5.62	17.4	5.16	17.4	5.16
-7.0	-7.6			21.8	6.41	21.3	6.30	20.0	5.84	19.4	5.62	18.7	5.40	17.4	4.96	17.4	4.96
-5.0	-5.6			22.6	6.42	21.3	5.98	20.0	5.54	19.4	5.33	18.7	5.12	17.4	4.72	17.4	4.72
-3.0	-3.7			22.6	6.11	21.3	5.70	20.0	5.29	19.4	5.09	18.7	4.89	17.4	4.51	17.4	4.51
0.0	-0.7			22.6	5.69	21.3	5.30	20.0	4.93	19.4	4.75	18.7	4.57	17.4	4.21	17.4	4.21
3.0	2.2			22.6	5.33	21.3	4.98	20.0	4.63	19.4	4.46	18.7	4.29	17.4	3.96	17.4	3.96
5.0	4.1			22.6	5.12	21.3	4.78	20.0	4.45	19.4	4.29	18.7	4.13	17.4	3.82	17.4	3.82
7.0	6.0			22.6	4.93	21.3	4.60	20.0	4.29	19.4	4.14	18.7	3.98	17.4	3.68	17.4	3.68
9.0	7.9			22.6	4.75	21.3	4.44	20.0	4.14	19.4	3.99	18.7	3.85	17.4	3.56	17.4	3.56
11.0	9.8			22.6	4.58	21.3	4.29	20.0	4.00	19.4	3.86	18.7	3.72	17.4	3.44	17.4	3.44
13.0	11.8			22.6	4.42	21.3	4.14	20.0	3.86	19.4	3.73	18.7	3.59	17.4	3.33	17.4	3.33
15.0	13.7			22.6	4.28	21.3	4.01	20.0	3.74	19.4	3.61	18.7	3.48	17.4	3.23	17.4	3.23

NOTES - ANMERKUNGEN - Σημειώσεις - NOTAS - REMARQUES - NOTE - OPMERKINGEN - Примечания - NOTLAR

- is shown as reference. When selecting the unit models, avoid the Outdoor air temperature range shown by ■.
 ■ dient als Verweis. Vermeiden Sie bei der Auswahl der Geräte modelle den als ■ markierten Temperaturbereich der Außenluft.
 ■ Η είναι ενδεικτική. ■ κατά την επιλογή των μοντέλων των μονάδων, αποφύγετε το εύρος θερμοκρασίας εξωτερικού αέρα που υποδεικνύεται.
 ■ semuestra como referencia. Cuando se seleccionen los modelos de unidad, evite el intervalo de temperaturas del aire exterior indicado mediante ■.
 ■ est montré comme référence. Lors du choix des modèles d'unités, évitez la plage de températures de l'air extérieur illustré par ■.
 ■ valorii riportati unicament com referință. Nu se alegă modele de unități care să aibă valori de temperatură ale aerului exterior indicate cu ■.
 ■ is als referentie getoond. Wanneer modellen van eenheden worden gekozen, vermijd dan het bereik van buitenluchttemperaturen geïllustreerd door ■.
 ■ показан как. Привыборе модели устройства избегайте внешнюю температуру воздуха, указанную в ■.
 ■ referans olarak gösterilmektedir. Ünite modellerini seçerken, belirtilen Dış hava sıcaklığı aralığından kaçınınız.
- The above table shows the average value of conditions which may occur.
 Die obige Tabelle zeigt den Durchschnittswert der Bedingungen, die auftreten können.
 Στον παραπάνω πίνακα αναγράφεται η μέση τιμή για συνθήκες που μπορεί να προκύψουν.
 La tabla de arriba muestra el valor medio de condiciones que pueden ocurrir.
 Le tableau ci-dessus donne la valeur moyenne pour des conditions qui peuvent survenir.
 La tabella in alto mostra il valore delle condizioni medie che si possono riscontrare.
 De tabel hierboven geeft de gemiddelde waarde aan van situaties die kunnen voorvallen.
 Таблица расположенная выше показывает среднее значение условий, которые могут наступить.
 Yukarıdaki tablo meydana gelebilecek koşulların ortalama değerini göstermektedir.

4TW33912-4(2)

4 Capacity tables

4 - 2 Heating Capacity Tables

RXYRQ10P		TC: Total Capacity: kW ; PI: Power Input: kW (compressor + outdoor fan motor)													
Combination (%)	kW (Capacity index)	Outdoor air temp.		Indoor air temp. °CDB											
				16.0		18.0		20.0		21.0		22.0		24.0	
				TC	PI	TC	PI	TC	PI	TC	PI	TC	PI	TC	PI
		°CDB	°CWB	kW		kW		kW		kW		kW		kW	
90	25.20 (225)	-19.8	-20.0	20.0	7.52	19.9	7.78	19.9	8.05	19.8	8.18	19.8	8.32	19.8	8.58
		-18.8	-19.0	20.3	7.60	20.3	7.87	20.2	8.13	20.2	8.26	20.2	8.39	20.1	8.65
		-16.7	-17.0	21.1	7.79	21.0	8.04	21.0	8.29	21.0	8.42	20.9	8.54	20.9	8.79
		-13.7	-15.0	22.0	7.98	21.9	8.22	21.9	8.46	21.8	8.58	21.8	8.70	21.8	8.94
		-11.8	-13.0	22.9	8.17	22.9	8.40	22.8	8.63	22.8	8.75	22.8	8.86	22.7	9.09
		-9.8	-11.0	24.0	8.36	24.0	8.58	23.9	8.80	23.9	8.91	23.9	9.03	23.8	9.25
		-9.5	-10.0	24.6	8.46	24.5	8.68	24.5	8.89	24.4	9.00	24.4	9.11	24.4	9.32
		-8.5	-9.1	25.1	8.55	25.1	8.76	25.0	8.97	25.0	9.07	25.0	9.18	24.7	9.27
		-7.0	-7.6	26.0	8.69	26.0	8.89	25.9	9.10	25.9	9.20	25.9	9.30	24.7	8.85
		-5.0	-5.6	27.4	8.88	27.3	9.07	27.3	9.26	27.2	9.36	26.5	9.07	24.7	8.32
		-3.0	-3.7	28.7	9.05	28.7	9.23	28.4	9.27	27.4	8.90	26.5	8.54	24.7	7.84
		0.0	-0.7	31.1	9.31	30.2	9.08	28.4	8.41	27.4	8.08	26.5	7.76	24.7	7.13
		3.0	2.2	32.0	8.87	30.2	8.26	28.4	7.66	27.4	7.37	26.5	7.08	24.7	6.52
		5.0	4.1	32.0	8.34	30.2	7.77	28.4	7.22	27.4	6.94	26.5	6.68	24.7	6.15
		7.0	6.0	32.0	7.84	30.2	7.32	28.4	6.80	27.4	6.55	26.5	6.30	24.7	5.81
		9.0	7.9	32.0	7.39	30.2	6.89	28.4	6.41	27.4	6.18	26.5	5.95	24.7	5.49
		11.0	9.8	32.0	6.96	30.2	6.50	28.4	6.06	27.4	5.84	26.5	5.62	24.7	5.20
		13.0	11.8	32.0	6.55	30.2	6.13	28.4	5.71	27.4	5.51	26.5	5.31	24.7	4.91
		15.0	13.7	32.0	6.19	30.2	5.79	28.4	5.41	27.4	5.22	26.5	5.03	24.7	4.66
		80	22.40 (200)	-19.8	-20.0	19.9	8.04	19.8	8.27	19.8	8.51	19.8	8.63	19.7	8.75
-18.8	-19.0			20.2	8.11	20.2	8.35	20.1	8.58	20.1	8.70	20.1	8.81	20.0	9.05
-16.7	-17.0			21.0	8.28	20.9	8.50	20.9	8.73	20.9	8.84	20.9	8.95	20.8	9.17
-13.7	-15.0			21.9	8.45	21.8	8.66	21.8	8.88	21.8	8.98	21.7	9.09	21.7	9.31
-11.8	-13.0			22.8	8.62	22.8	8.83	22.7	9.03	22.7	9.13	22.7	9.24	22.0	8.99
-9.8	-11.0			23.9	8.79	23.9	8.99	23.8	9.19	23.8	9.28	23.6	9.26	22.0	8.49
-9.5	-10.0			24.5	8.88	24.4	9.07	24.4	9.26	24.4	9.36	23.6	8.99	22.0	8.24
-8.5	-9.1			25.0	8.96	25.0	9.15	24.9	9.33	24.4	9.12	23.6	8.75	22.0	8.02
-7.0	-7.6			25.9	9.09	25.9	9.27	25.2	9.07	24.4	8.71	23.6	8.36	22.0	7.67
-5.0	-5.6			27.3	9.25	26.8	9.20	25.2	8.52	24.4	8.19	23.6	7.86	22.0	7.22
-3.0	-3.7			28.4	9.30	26.8	8.66	25.2	8.02	24.4	7.72	23.6	7.41	22.0	6.82
0.0	-0.7			28.4	8.44	26.8	7.86	25.2	7.30	24.4	7.03	23.6	6.75	22.0	6.22
3.0	2.2			28.4	7.69	26.8	7.17	25.2	6.67	24.4	6.42	23.6	6.18	22.0	5.70
5.0	4.1			28.4	7.24	26.8	6.76	25.2	6.29	24.4	6.06	23.6	5.84	22.0	5.39
7.0	6.0			28.4	6.82	26.8	6.38	25.2	5.94	24.4	5.73	23.6	5.52	22.0	5.10
9.0	7.9			28.4	6.44	26.8	6.02	25.2	5.61	24.4	5.41	23.6	5.22	22.0	4.83
11.0	9.8			28.4	6.08	26.8	5.69	25.2	5.31	24.4	5.12	23.6	4.94	22.0	4.58
13.0	11.8			28.4	5.73	26.8	5.37	25.2	5.02	24.4	4.84	23.6	4.67	22.0	4.33
15.0	13.7			28.4	5.42	26.8	5.09	25.2	4.76	24.4	4.59	23.6	4.43	22.0	4.12

NOTES - ANMERKUNGEN - Σημειώσεις - NOTAS - REMARQUES - NOTE - OPMERKINGEN - Примечания - NOTLAR

- is shown as reference. When selecting the unit models, avoid the Outdoor air temperature range shown by .
 dient als Verweis. Vermeiden Sie bei der Auswahl der Geräte modelle den als markierten Temperaturbereich der Außenluft.
 Η είναι ενδεικτική. κατά την επιλογή των μοντέλων των μονάδων, αποφύγετε το εύρος θερμοκρασίας εξωτερικού αέρα που υποδεικνύεται .
 semuestra como referencia. Cuando se seleccionen los modelos de unidad, evite el intervalo de temperaturas del aire exterior indicado mediante .
 est montré comme référence. Lors du choix des modèles d'unités, évitez la plage de températures de l'air extérieur illustré par .
 valorii riportati unicament com referință. Nu se alegă modele de unități care să fie în afara intervalului de temperatură al aerului exterior indicat prin .
 is als referentie getoond. Wanneer modellen van eenheden worden gekozen, vermijd dan het bereik van buitenluchttemperaturen geïllustreerd door .
- показан как. Привыборе модели устройства избегайте внешнюю температуру воздуха, указанную в .
 referans olarak gösterilmektedir. Ünite modellerini seçerken, belirtilen Dış hava sıcaklığı aralığından kaçınınız .

The above table shows the average value of conditions which may occur.
 Die obige Tabelle zeigt den Durchschnittswert der Bedingungen, die auftreten können.
 Στον παραπάνω πίνακα αναγράφεται η μέση τιμή για συνθήκες που μπορεί να προκύψουν.
 La tabla de arriba muestra el valor medio de condiciones que pueden ocurrir.
 Le tableau ci-dessus donne la valeur moyenne pour des conditions qui peuvent survenir.
 La tabella in alto mostra il valore delle condizioni medie che si possono riscontrare.
 De tabel hierboven geeft de gemiddelde waarde aan van situaties die kunnen voorvallen.
 Таблица расположенная выше показывает среднее значение условий, которые могут наступить.
 Yukarıdaki tablo meydana gelebilecek koşulların ortalama değerini göstermektedir.

4TW33912-4(2)

4 Capacity tables

4 - 2 Heating Capacity Tables

RXYRQ12P		TC: Total Capacity: kW ; PI: Power Input: kW (compressor + outdoor fan motor)													
Combination (%)	kW (Capacity index)	Outdoor air temp.		Indoor air temp. °CDB											
				16.0		18.0		20.0		21.0		22.0		24.0	
				TC	PI	TC	PI	TC	PI	TC	PI	TC	PI	TC	PI
		°CDB	°CWB	kW		kW		kW		kW		kW		kW	
90	30.15 (270)	-19.8	-20.0	20.3	6.63	20.2	6.96	20.2	7.29	20.2	7.46	20.1	7.62	20.1	7.95
		-18.8	-19.0	20.7	6.74	20.6	7.06	20.5	7.39	20.5	7.55	20.5	7.71	20.4	8.03
		-16.7	-17.0	21.4	6.96	21.4	7.27	21.3	7.58	21.3	7.74	21.3	7.89	21.2	8.20
		-13.7	-15.0	22.3	7.19	22.3	7.48	22.2	7.78	22.2	7.93	22.1	8.08	22.1	8.38
		-11.8	-13.0	23.3	7.42	23.2	7.70	23.2	7.99	23.1	8.13	23.1	8.27	23.1	8.56
		-9.8	-11.0	24.4	7.65	24.3	7.92	24.3	8.20	24.2	8.33	24.2	8.47	24.1	8.74
		-9.5	-10.0	24.9	7.77	24.9	8.03	24.8	8.30	24.8	8.43	24.8	8.56	24.7	8.83
		-8.5	-9.1	25.5	7.87	25.4	8.13	25.4	8.39	25.3	8.52	25.3	8.65	25.3	8.91
		-7.0	-7.6	26.4	8.04	26.4	8.29	26.3	8.54	26.3	8.67	26.3	8.79	26.2	9.04
		-5.0	-5.6	27.8	8.27	27.7	8.50	27.7	8.74	27.6	8.86	27.6	8.98	27.5	9.22
		-3.0	-3.7	29.1	8.47	29.1	8.70	29.0	8.92	29.0	9.04	29.0	9.15	28.9	9.37
		0.0	-0.7	31.5	8.78	31.4	8.99	31.4	9.20	31.3	9.30	31.3	9.40	29.4	8.76
		3.0	2.2	34.0	9.06	33.9	9.25	33.8	9.40	32.7	9.05	31.6	8.69	29.4	8.00
		5.0	4.1	35.7	9.23	35.6	9.41	33.8	8.85	32.7	8.52	31.6	8.19	29.4	7.55
		7.0	6.0	37.5	9.39	35.9	8.97	33.8	8.34	32.7	8.03	31.6	7.72	29.4	7.12
		9.0	7.9	38.1	9.05	35.9	8.45	33.8	7.86	32.7	7.57	31.6	7.29	29.4	6.73
		11.0	9.8	38.1	8.53	35.9	7.97	33.8	7.42	32.7	7.15	31.6	6.89	29.4	6.36
		13.0	11.8	38.1	8.02	35.9	7.50	33.8	6.99	32.7	6.74	31.6	6.49	29.4	6.01
		15.0	13.7	38.1	7.57	35.9	7.09	33.8	6.61	32.7	6.38	31.6	6.15	29.4	5.70
		80	26.80 (240)	-19.8	-20.0	20.2	7.28	20.1	7.57	20.1	7.86	20.1	8.01	20.0	8.15
-18.8	-19.0			20.5	7.37	20.5	7.66	20.4	7.94	20.4	8.09	20.4	8.23	20.3	8.52
-16.7	-17.0			21.3	7.57	21.3	7.84	21.2	8.12	21.2	8.26	21.2	8.39	21.1	8.67
-13.7	-15.0			22.2	7.77	22.1	8.03	22.1	8.30	22.1	8.43	22.0	8.56	22.0	8.83
-11.8	-13.0			23.2	7.97	23.1	8.23	23.1	8.48	23.0	8.61	23.0	8.74	23.0	8.99
-9.8	-11.0			24.3	8.18	24.2	8.42	24.2	8.67	24.1	8.79	24.1	8.91	24.0	9.15
-9.5	-10.0			24.8	8.29	24.8	8.52	24.7	8.76	24.7	8.88	24.7	8.99	24.6	9.23
-8.5	-9.1			25.4	8.38	25.3	8.61	25.3	8.84	25.2	8.95	25.2	9.07	25.2	9.30
-7.0	-7.6			26.3	8.53	26.3	8.75	26.2	8.97	26.2	9.09	26.2	9.20	26.1	9.42
-5.0	-5.6			27.7	8.73	27.6	8.94	27.6	9.15	27.5	9.26	27.5	9.36	26.1	8.88
-3.0	-3.7			29.0	8.91	29.0	9.11	28.9	9.31	28.9	9.41	28.1	9.11	26.1	8.38
0.0	-0.7			31.4	9.19	31.3	9.37	30.0	8.97	29.0	8.63	28.1	8.30	26.1	7.64
3.0	2.2			33.8	9.43	31.9	8.80	30.0	8.19	29.0	7.88	28.1	7.58	26.1	7.00
5.0	4.1			33.9	8.88	31.9	8.29	30.0	7.72	29.0	7.44	28.1	7.16	26.1	6.61
7.0	6.0			33.9	8.37	31.9	7.82	30.0	7.28	29.0	7.02	28.1	6.76	26.1	6.25
9.0	7.9			33.9	7.89	31.9	7.38	30.0	6.88	29.0	6.63	28.1	6.39	26.1	5.92
11.0	9.8			33.9	7.45	31.9	6.97	30.0	6.50	29.0	6.28	28.1	6.05	26.1	5.61
13.0	11.8			33.9	7.01	31.9	6.57	30.0	6.14	29.0	5.93	28.1	5.72	26.1	5.30
15.0	13.7			33.9	6.64	31.9	6.22	30.0	5.82	29.0	5.62	28.1	5.42	26.1	5.04

NOTES - ANMERKUNGEN - Σημειώσεις - NOTAS - REMARQUES - NOTE - OPMERKINGEN - Примечания - NOTLAR

- is shown as reference. When selecting the unit models, avoid the Outdoor air temperature range shown by .
dient als Verweis. Vermeiden Sie bei der Auswahl der Geräte modelle den als markierten Temperaturbereich der Außenluft
Η είναι ενδεικτική. κατά την επιλογή των μοντέλων των μονάδων, αποφύγετε το εύρος θερμοκρασίας εξωτερικού αέρα που υποδεικνύεται
semuestra como referencia. Cuando se seleccionen los modelos de unidad, evite el intervalo de temperaturas del aire exterior indicado mediante
est montré comme référence. Lors du choix des modèles d'unités, évitez la plage de températures de l'air extérieur illustré par
valorii riportati unicament com referință. Nu se alegă modele de unități care să fie în afara intervalului de temperatură al aerului exterior indicat de
is als referentie getoond. Wanneer modellen van eenheden worden gekozen, vermijd dan het bereik van buitenluchttemperaturen geïllustreerd door
 - показан как. Привыборе модели устройства избегайте внешнюю температуру воздуха, указанную в
referans olarak gösterilmektedir. Ünite modellerini seçerken, belirtilen Dış hava sıcaklığı aralığından kaçınınız
2. The above table shows the average value of conditions which may occur.
 Die obige Tabelle zeigt den Durchschnittswert der Bedingungen, die auftreten können.
 Στον παραπάνω πίνακα αναγράφεται η μέση τιμή για συνθήκες που μπορεί να προκύψουν.
 La tabla de arriba muestra el valor medio de condiciones que pueden ocurrir.
 Le tableau ci-dessus donne la valeur moyenne pour des conditions qui peuvent survenir.
 La tabella in alto mostra il valore delle condizioni medie che si possono riscontrare.
 De tabel hierboven geeft de gemiddelde waarde aan van situaties die kunnen voorvallen.
 Таблица расположенная выше показывает среднее значение условий, которые могут наступить.
 Yukarıdaki tablo meydana gelebilecek koşulların ortalama değerini göstermektedir.

4TW33912-4(2)

4 Capacity tables

4 - 2 Heating Capacity Tables

RXYRQ14P		TC: Total Capacity: kW ; PI: Power Input: kW (compressor + outdoor fan motor)													
Combination (%)	kW (Capacity index)	Outdoor air temp.		Indoor air temp. °CDB											
				16.0		18.0		20.0		21.0		22.0		24.0	
				TC	PI	TC	PI	TC	PI	TC	PI	TC	PI	TC	PI
		°CDB	°CWB	kW		kW		kW		kW		kW		kW	
90	36.00 (315)	-19.8	-20.0	27.6	10.31	27.5	10.70	27.4	11.09	27.4	11.29	27.4	11.5	27.3	11.9
		-18.8	-19.0	28.1	10.44	28.0	10.82	28.0	11.21	27.9	11.4	27.9	11.6	27.8	12.0
		-16.7	-17.0	29.2	10.71	29.1	11.08	29.1	11.4	29.0	11.6	29.0	11.8	28.9	12.2
		-13.7	-15.0	30.4	10.98	30.4	11.3	30.3	11.7	30.3	11.9	30.2	12.0	30.1	12.4
		-11.8	-13.0	31.8	11.3	31.7	11.6	31.6	11.9	31.6	12.1	31.6	12.3	31.5	12.6
		-9.8	-11.0	33.3	11.5	33.2	11.9	33.1	12.2	33.1	12.3	33.0	12.5	33.0	12.8
		-9.5	-10.0	34.0	11.7	34.0	12.0	33.9	12.3	33.9	12.5	33.8	12.6	33.8	12.9
		-8.5	-9.1	34.8	11.8	34.7	12.1	34.6	12.4	34.6	12.6	34.6	12.7	34.5	13.0
		-7.0	-7.6	36.1	12.0	36.0	12.3	35.9	12.6	35.9	12.7	35.8	12.9	35.3	12.9
		-5.0	-5.6	37.9	12.3	37.8	12.5	37.7	12.8	37.7	13.0	37.7	13.1	35.3	12.1
		-3.0	-3.7	39.7	12.5	39.6	12.8	39.6	13.0	39.2	13.0	37.9	12.5	35.3	11.4
		0.0	-0.7	42.8	12.9	42.8	13.1	40.5	12.3	39.2	11.8	37.9	11.3	35.3	10.4
		3.0	2.2	45.7	13.0	43.1	12.1	40.5	11.2	39.2	10.8	37.9	10.4	35.3	9.55
		5.0	4.1	45.7	12.2	43.1	11.4	40.5	10.6	39.2	10.2	37.9	9.79	35.3	9.02
		7.0	6.0	45.7	11.5	43.1	10.7	40.5	10.0	39.2	9.61	37.9	9.24	35.3	8.53
		9.0	7.9	45.7	10.9	43.1	10.1	40.5	9.42	39.2	9.08	37.9	8.74	35.3	8.07
		11.0	9.8	45.7	10.2	43.1	9.6	40.5	8.91	39.2	8.59	37.9	8.27	35.3	7.64
		13.0	11.8	45.7	9.6	43.1	9.02	40.5	8.41	39.2	8.11	37.9	7.81	35.3	7.23
15.0	13.7	45.7	9.1	43.1	8.54	40.5	7.97	39.2	7.69	37.9	7.41	35.3	6.86		
80	32.00 (280)	-19.8	-20.0	27.5	11.07	27.4	11.42	27.3	11.8	27.3	11.9	27.3	12.1	27.2	12.5
		-18.8	-19.0	28.0	11.19	27.9	11.5	27.8	11.9	27.8	12.0	27.8	12.2	27.7	12.6
		-16.7	-17.0	29.1	11.4	29.0	11.8	28.9	12.1	28.9	12.2	28.9	12.4	28.8	12.7
		-13.7	-15.0	30.3	11.7	30.2	12.0	30.2	12.3	30.1	12.5	30.1	12.6	30.0	12.9
		-11.8	-13.0	31.6	11.9	31.6	12.2	31.5	12.5	31.5	12.7	31.5	12.8	31.4	13.1
		-9.8	-11.0	33.1	12.2	33.1	12.5	33.0	12.7	33.0	12.9	32.9	13.0	31.4	12.4
		-9.5	-10.0	33.9	12.3	33.8	12.6	33.8	12.9	33.8	13.0	33.7	13.1	31.4	12.0
		-8.5	-9.1	34.6	12.4	34.6	12.7	34.5	12.9	34.5	13.1	33.7	12.8	31.4	11.7
		-7.0	-7.6	35.9	12.6	35.9	12.8	35.8	13.1	34.8	12.7	33.7	12.2	31.4	11.2
		-5.0	-5.6	37.7	12.8	37.7	13.1	36.0	12.4	34.8	11.9	33.7	11.5	31.4	10.5
		-3.0	-3.7	39.6	13.0	38.3	12.6	36.0	11.7	34.8	11.3	33.7	10.8	31.4	9.96
		0.0	-0.7	40.6	12.3	38.3	11.5	36.0	10.7	34.8	10.3	33.7	9.88	31.4	9.10
		3.0	2.2	40.6	11.3	38.3	10.5	36.0	9.77	34.8	9.41	33.7	9.05	31.4	8.35
		5.0	4.1	40.6	10.6	38.3	9.9	36.0	9.22	34.8	8.89	33.7	8.56	31.4	7.90
		7.0	6.0	40.6	10.0	38.3	9.36	36.0	8.72	34.8	8.40	33.7	8.09	31.4	7.48
		9.0	7.9	40.6	9.46	38.3	8.85	36.0	8.25	34.8	7.95	33.7	7.66	31.4	7.09
		11.0	9.8	40.6	8.94	38.3	8.37	36.0	7.81	34.8	7.54	33.7	7.27	31.4	6.73
		13.0	11.8	40.6	8.44	38.3	7.91	36.0	7.38	34.8	7.13	33.7	6.88	31.4	6.38
15.0	13.7	40.6	8.00	38.3	7.50	36.0	7.01	34.8	6.77	33.7	6.53	31.4	6.07		

NOTES - ANMERKUNGEN - Σημειώσεις - NOTAS - REMARQUES - NOTE - OPMERKINGEN - Примечания - NOTLAR

- is shown as reference. When selecting the unit models, avoid the Outdoor air temperature range shown by ■.
 ■ dient als Verweis. Vermeiden Sie bei der Auswahl der Geräte modelle den als ■ markierten Temperaturbereich der Außenluft.
 ■ Η είναι ενδεικτική. ■ κατά την επιλογή των μοντέλων των μονάδων, αποφύγετε το εύρος θερμοκρασίας εξωτερικού αέρα που υποδεικνύεται.
 ■ semuestra como referencia. Cuando se seleccionen los modelos de unidad, evite el intervalo de temperaturas del aire exterior indicado mediante ■.
 ■ est montré comme référence. Lors du choix des modèles d'unités, évitez la plage de températures de l'air extérieur illustré par ■.
 ■ valorii riportati unicament com referință. Nu se alegă modele de unități care să aibă valori de temperatură ale aerului exterior indicate cu ■.
 ■ is als referentie getoond. Wanneer modellen van eenheden worden gekozen, vermijd dan het bereik van buitenluchttemperaturen geïllustreerd door ■.
 ■ показан как. Привыборе модели устройства избегайте внешнюю температуру воздуха, указанную в ■.
 ■ referans olarak gösterilmektedir. Ünite modellerini seçerken, belirtilen dış hava sıcaklığı aralığından kaçınınız.
- The above table shows the average value of conditions which may occur.
 Die obige Tabelle zeigt den Durchschnittswert der Bedingungen, die auftreten können.
 Στον παραπάνω πίνακα αναγράφεται η μέση τιμή για συνθήκες που μπορεί να προκύψουν.
 La tabla de arriba muestra el valor medio de condiciones que pueden ocurrir.
 Le tableau ci-dessus donne la valeur moyenne pour des conditions qui peuvent survenir.
 La tabella in alto mostra il valore delle condizioni medie che si possono riscontrare.
 De tabel hierboven geeft de gemiddelde waarde aan van situaties die kunnen voorvallen.
 Таблица расположенная выше показывает среднее значение условий, которые могут наступить.
 Yukarıdaki tablo meydana gelebilecek koşulların ortalama değerini göstermektedir.

4TW33912-4(2)

4 Capacity tables

4 - 2 Heating Capacity Tables

RXYRQ16 P		TC: Total Capacity: kW ; PI: Power Input: kW (compressor + outdoor fan motor)													
Combination (%)	kW (Capacity index)	Outdoor air temp.		Indoor air temp. °CDB											
				16.0		18.0		20.0		21.0		22.0		24.0	
				TC	PI	TC	PI	TC	PI	TC	PI	TC	PI	TC	PI
		°CDB	°CWB	kW		kW		kW		kW		kW		kW	
90	40.50 (360)	-19.8	-20.0	30.1	11.29	30.0	11.74	29.9	12.19	29.9	12.4	29.8	12.6	29.7	13.1
		-18.8	-19.0	30.6	11.44	30.5	11.88	30.4	12.3	30.4	12.5	30.4	12.8	30.3	13.2
		-16.7	-17.0	31.8	11.75	31.7	12.2	31.6	12.6	31.6	12.8	31.6	13.0	31.5	13.4
		-13.7	-15.0	33.1	12.1	33.1	12.5	33.0	12.9	32.9	13.1	32.9	13.3	32.8	13.7
		-11.8	-13.0	34.6	12.4	34.5	12.8	34.5	13.2	34.4	13.3	34.4	13.5	34.3	13.9
		-9.8	-11.0	36.2	12.7	36.1	13.1	36.1	13.4	36.0	13.6	36.0	13.8	35.9	14.2
		-9.5	-10.0	37.1	12.9	37.0	13.2	36.9	13.6	36.9	13.8	36.8	13.9	36.8	14.3
		-8.5	-9.1	37.9	13.0	37.8	13.3	37.7	13.7	37.7	13.9	37.6	14.1	37.6	14.4
		-7.0	-7.6	39.3	13.2	39.2	13.6	39.1	13.9	39.1	14.1	39.0	14.2	39.0	14.6
		-5.0	-5.6	41.2	13.5	41.2	13.8	41.1	14.2	41.0	14.3	41.0	14.5	39.2	13.9
		-3.0	-3.7	43.2	13.8	43.2	14.1	43.1	14.4	43.1	14.6	42.1	14.2	39.2	13.1
		0.0	-0.7	46.7	14.2	46.6	14.5	45.0	14.0	43.6	13.5	42.1	13.0	39.2	11.9
		3.0	2.2	50.2	14.6	47.9	13.8	45.0	12.8	43.6	12.3	42.1	11.8	39.2	10.9
		5.0	4.1	50.8	14.0	47.9	13.0	45.0	12.1	43.6	11.6	42.1	11.2	39.2	10.3
		7.0	6.0	50.8	13.1	47.9	12.3	45.0	11.4	43.6	11.0	42.1	10.6	39.2	9.7
		9.0	7.9	50.8	12.4	47.9	11.6	45.0	10.8	43.6	10.4	42.1	10.0	39.2	9.2
		11.0	9.8	50.8	11.7	47.9	10.9	45.0	10.2	43.6	9.8	42.1	9.4	39.2	8.73
13.0	11.8	50.8	11.0	47.9	10.3	45.0	9.6	43.6	9.3	42.1	8.92	39.2	8.25		
15.0	13.7	50.8	10.4	47.9	9.8	45.0	9.1	43.6	8.78	42.1	8.46	39.2	7.83		
80	36.00 (320)	-19.8	-20.0	29.9	12.17	29.8	12.6	29.8	13.0	29.7	13.2	29.7	13.4	29.6	13.8
		-18.8	-19.0	30.4	12.3	30.4	12.7	30.3	13.1	30.3	13.3	30.2	13.5	30.2	13.9
		-16.7	-17.0	31.7	12.6	31.6	12.9	31.5	13.3	31.5	13.5	31.4	13.7	31.4	14.1
		-13.7	-15.0	33.0	12.9	32.9	13.2	32.8	13.6	32.8	13.8	32.8	13.9	32.7	14.3
		-11.8	-13.0	34.5	13.1	34.4	13.5	34.3	13.8	34.3	14.0	34.3	14.2	34.2	14.5
		-9.8	-11.0	36.1	13.4	36.0	13.7	35.9	14.1	35.9	14.2	35.9	14.4	34.9	14.1
		-9.5	-10.0	36.9	13.6	36.9	13.9	36.8	14.2	36.8	14.4	36.7	14.5	34.9	13.7
		-8.5	-9.1	37.7	13.7	37.7	14.0	37.6	14.3	37.6	14.5	37.4	14.6	34.9	13.4
		-7.0	-7.6	39.1	13.9	39.0	14.2	39.0	14.5	38.7	14.5	37.4	13.9	34.9	12.8
		-5.0	-5.6	41.1	14.2	41.0	14.4	40.0	14.2	38.7	13.6	37.4	13.1	34.9	12.0
		-3.0	-3.7	43.1	14.4	42.6	14.4	40.0	13.4	38.7	12.9	37.4	12.4	34.9	11.4
		0.0	-0.7	45.1	14.1	42.6	13.1	40.0	12.2	38.7	11.7	37.4	11.3	34.9	10.4
		3.0	2.2	45.1	12.9	42.6	12.0	40.0	11.2	38.7	10.7	37.4	10.3	34.9	9.54
		5.0	4.1	45.1	12.1	42.6	11.3	40.0	10.5	38.7	10.1	37.4	9.77	34.9	9.02
		7.0	6.0	45.1	11.4	42.6	10.7	40.0	10.0	38.7	9.59	37.4	9.24	34.9	8.54
		9.0	7.9	45.1	10.8	42.6	10.1	40.0	9.42	38.7	9.08	37.4	8.75	34.9	8.10
		11.0	9.8	45.1	10.2	42.6	9.6	40.0	8.92	38.7	8.60	37.4	8.29	34.9	7.69
13.0	11.8	45.1	9.6	42.6	9.03	40.0	8.43	38.7	8.14	37.4	7.85	34.9	7.28		
15.0	13.7	45.1	9.1	42.6	8.56	40.0	8.00	38.7	7.73	37.4	7.46	34.9	6.92		

NOTES - ANMERKUNGEN - Σημειώσεις - NOTAS - REMARQUES - NOTE - OPMERKINGEN - Примечания - NOTLAR

- is shown as reference. When selecting the unit models, avoid the Outdoor air temperature range shown by ■
 ■ dient als Verweis. Vermeiden Sie bei der Auswahl der Geräte modelle den als ■ markierten Temperaturbereich der Außenluft
 ■ Η είναι ενδεικτική. ■ κατά την επιλογή των μοντέλων των μονάδων, αποφύγετε το εύρος θερμοκρασίας εξωτερικού αέρα που υποδεικνύεται
 ■ semuestra como referencia. Cuando se seleccionen los modelos de unidad, evite el intervalo de temperaturas del aire exterior indicado mediante ■
 ■ est montré comme référence. Lors du choix des modèles d'unités, évitez la plage de températures de l'air extérieur illustré par ■
 ■ valorii riportati unicament com referință. Nu se alegă modele de unități care să fie în afara intervalului de temperatură al aerului exterior indicat prin ■
 ■ is als referentie getoond. Wanneer modellen van eenheden worden gekozen, vermijd dan het bereik van buitenluchttemperaturen geïllustreerd door ■
- показан как. Привыборе модели устройства избегайте внешнюю температуру воздуха, указанную в ■
 ■ referans olarak gösterilmektedir. Ünite modellerini seçerken, belirtilen Dış hava sıcaklığı aralığından kaçınınız ■
 2. The above table shows the average value of conditions which may occur.
 Die obige Tabelle zeigt den Durchschnittswert der Bedingungen, die auftreten können.
 Στον παραπάνω πίνακα αναγράφεται η μέση τιμή για συνθήκες που μπορεί να προκύψουν.
 La tabla de arriba muestra el valor medio de condiciones que pueden ocurrir.
 Le tableau ci-dessus donne la valeur moyenne pour des conditions qui peuvent survenir.
 La tabella in alto mostra il valore delle condizioni medie che si possono riscontrare.
 De tabel hierboven geeft de gemiddelde waarde aan van situaties die kunnen voorvallen.
 Таблица расположенная выше показывает среднее значение условий, которые могут наступить.
 Yukarıdaki tablo meydana gelebilecek koşulların ortalama değerini göstermektedir.

4TW33912-4(2)

4 Capacity tables

4 - 2 Heating Capacity Tables

RXYRQ18P		TC: Total Capacity: kW ; PI: Power Input: kW (compressor + outdoor fan motor)													
Combination (%)	kW (Capacity index)	Outdoor air temp.		Indoor air temp. °CDB											
				16.0		18.0		20.0		21.0		22.0		24.0	
				TC	PI	TC	PI	TC	PI	TC	PI	TC	PI	TC	PI
		°CDB	°CWB	kW		kW		kW		kW		kW		kW	
90	44.10 (405)	-19.80	-20.00	30.7	10.7	30.7	11.3	30.6	11.8	30.5	12.0	30.5	12.3	30.4	12.8
		-18.80	-19.00	31.3	10.9	31.2	11.4	31.1	11.9	31.1	12.2	31.0	12.5	31.0	13.0
		-16.70	-17.00	32.5	11.3	32.4	11.8	32.4	12.3	32.3	12.5	32.3	12.8	32.2	13.3
		-13.70	-15.00	33.9	11.7	33.8	12.1	33.7	12.6	33.7	12.8	33.6	13.1	33.5	13.6
		-11.80	-13.00	35.4	12.0	35.3	12.5	35.2	12.9	35.2	13.2	35.1	13.4	35.0	13.9
		-9.80	-11.00	37.0	12.4	36.9	12.8	36.9	13.3	36.8	13.5	36.8	13.7	36.7	14.2
		-9.50	-10.00	37.9	12.6	37.8	13.0	37.7	13.4	37.7	13.7	37.6	13.9	37.5	14.3
		-8.50	-9.10	38.7	12.8	38.6	13.2	38.5	13.6	38.5	13.8	38.5	14.0	38.4	14.4
		-7.00	-7.60	40.1	13.0	40.0	13.4	40.0	13.8	39.9	14.0	39.9	14.2	39.8	14.6
		-5.00	-5.60	42.1	13.4	42.1	13.8	42.0	14.2	41.9	14.4	41.9	14.5	41.8	14.9
		-3.00	-3.70	44.2	13.7	44.1	14.1	44.0	14.5	44.0	14.6	43.9	14.8	43.8	15.2
		0.0	-0.70	47.7	14.2	47.6	14.6	47.5	14.9	47.4	15.1	47.4	15.2	44.3	14.1
		3.00	2.20	51.3	14.7	51.2	15.0	50.9	15.2	49.2	14.6	47.6	14.0	44.3	12.9
		5.00	4.10	53.9	15.0	53.8	15.3	50.9	14.3	49.2	13.8	47.6	13.2	44.3	12.2
		7.00	6.00	56.5	15.2	54.1	14.5	50.9	13.5	49.2	13.0	47.6	12.5	44.3	11.5
		9.00	7.90	57.4	14.7	54.1	13.7	50.9	12.8	49.2	12.3	47.6	11.8	44.3	10.9
		11.00	9.80	57.4	13.9	54.1	13.0	50.9	12.1	49.2	11.6	47.6	11.2	44.3	10.4
13.00	11.80	57.4	13.1	54.1	12.2	50.9	11.4	49.2	11.0	47.6	10.6	44.3	9.8		
15.00	13.70	57.4	12.4	54.1	11.6	50.9	10.8	49.2	10.4	47.6	10.1	44.3	9.31		
80	39.20 (360)	-19.80	-20.00	30.6	11.8	30.5	12.2	30.4	12.7	30.4	12.9	30.3	13.2	30.3	13.6
		-18.80	-19.00	31.1	11.9	31.1	12.4	31.0	12.8	30.9	13.1	30.9	13.3	30.8	13.8
		-16.70	-17.00	32.4	12.2	32.3	12.7	32.2	13.1	32.2	13.3	32.1	13.6	32.0	14.0
		-13.70	-15.00	33.7	12.6	33.6	13.0	33.6	13.4	33.5	13.6	33.5	13.9	33.4	14.3
		-11.80	-13.00	35.2	12.9	35.1	13.3	35.1	13.7	35.0	13.9	35.0	14.1	34.9	14.5
		-9.80	-11.00	36.9	13.3	36.8	13.6	36.7	14.0	36.7	14.2	36.6	14.4	36.5	14.8
		-9.50	-10.00	37.7	13.4	37.7	13.8	37.6	14.2	37.5	14.4	37.5	14.6	37.4	14.9
		-8.50	-9.10	38.5	13.6	38.5	13.9	38.4	14.3	38.3	14.5	38.3	14.7	38.2	15.1
		-7.00	-7.60	40.0	13.8	39.9	14.2	39.8	14.5	39.8	14.7	39.7	14.9	39.4	15.1
		-5.00	-5.60	42.0	14.1	41.9	14.5	41.8	14.8	41.8	15.0	41.7	15.2	39.4	14.2
		-3.00	-3.70	44.0	14.4	43.9	14.8	43.9	15.1	43.7	15.2	42.3	14.6	39.4	13.4
		0.0	-0.70	47.5	14.9	47.4	15.2	45.2	14.4	43.7	13.9	42.3	13.3	39.4	12.3
		3.0	2.2	51.0	15.2	48.1	14.2	45.2	13.2	43.7	12.7	42.3	12.2	39.4	11.3
		5.0	4.1	51.0	14.4	48.1	13.4	45.2	12.5	43.7	12.0	42.3	11.6	39.4	10.7
		7.0	6.0	51.0	13.6	48.1	12.7	45.2	11.8	43.7	11.4	42.3	11.0	39.4	10.1
		9.0	7.9	51.0	12.8	48.1	12.0	45.2	11.2	43.7	10.8	42.3	10.4	39.4	9.61
		11.0	9.8	51.0	12.1	48.1	11.3	45.2	10.6	43.7	10.2	42.3	9.8	39.4	9.12
13.0	11.8	51.0	11.4	48.1	10.7	45.2	10.0	43.7	9.7	42.3	9.32	39.4	8.65		
15.0	13.7	51.0	10.8	48.1	10.2	45.2	9.5	43.7	9.19	42.3	8.86	39.4	8.23		

NOTES - ANMERKUNGEN - Σημειώσεις - NOTAS - REMARQUES - NOTE - OPMERKINGEN - Примечания - NOTLAR

- is shown as reference. When selecting the unit models, avoid the Outdoor air temperature range shown by ■
 ■ dient als Verweis. Vermeiden Sie bei der Auswahl der Gerätemodelle den als ■ markierten Temperaturbereich der Außenluft
 ■ H είναι ενδεικτική. ■ κατά την επιλογή των μοντέλων των μονάδων, αποφύγετε το εύρος θερμοκρασίας εξωτερικού αέρα που υποδεικνύεται
 ■ semuestra como referencia. Cuando se seleccionen los modelos de unidad, evite el intervalo de temperaturas del aire exterior indicado mediante ■
 ■ est montré comme référence. Lors du choix des modèles d'unités, évitez la plage de températures de l'air extérieur illustré par ■
 ■ valorii riportati unicament ca referință. Nu se alegă modele de unități care să aibă valori de temperatură ale aerului exterior indicate cu ■
 ■ is als referentie getoond. Wanneer modellen van eenheden worden gekozen, vermijd dan het bereik van buitenluchttemperaturen geïllustreerd door ■
- показан как. Привыборе модели устройства избегайте внешнюю температуру воздуха, указанную в ■
 ■ referans olarak gösterilmektedir. Ünite modellerini seçerken, belirtilen Dış hava sıcaklığı aralığından kaçınınız ■
 2. The above table shows the average value of conditions which may occur.
 Die obige Tabelle zeigt den Durchschnittswert der Bedingungen, die auftreten können.
 Στον παραπάνω πίνακα αναγράφεται η μέση τιμή για συνθήκες που μπορεί να προκύψουν.
 La tabla de arriba muestra el valor medio de condiciones que pueden ocurrir.
 Le tableau ci-dessus donne la valeur moyenne pour des conditions qui peuvent survenir.
 La tabella in alto mostra il valore delle condizioni medie che si possono riscontrare.
 De tabel hierboven geeft de gemiddelde waarde aan van situaties die kunnen voorvallen.
 Таблица расположенная выше показывает среднее значение условий, которые могут наступить.
 Yukarıdaki tablo meydana gelebilecek koşulların ortalama değerini göstermektedir.

4TW33912-4(2)

4 Capacity tables

4 - 3 Integrated Heating Capacity Correction Factor

RXYRQ-P

Integrated heating capacity coefficient

The heating capacity tables do not take account of the reduction in capacity, when frost has accumulated or while the defrosting operation is in progress. The capacity values, which take these factors into account, in other words, the integrated heating capacity values, can be calculated as follows:

Formula:

Integrated heating capacity = A

Value given in table of capacity characteristics = B

Integrating correction factor for frost accumulation (kW) = C

$$A = B \times C$$

$$C = C_1 \times C_2$$

The correction factor C, can be found in the table below

Inlet port temperature of heat exchanger (°C/RH 85%)	-7	-5	-3	0	3	5	7
Correction factor C ₁	0.95	0.93	0.88	0.84	0.85	0.90	1.0

$$C_2 = 0.17 \times \left(\frac{VRV_{indoor} \text{ index}}{\sum \text{index all indoor units}} \right) + 0.83$$

Example:

Outdoor temperature: -3°C

Total VRV indoor unit capacity index: 80

Total RA or Sky air indoor unit capacity index: 140

$$\left. \begin{aligned} C_1 &= 0.88 \\ C_2 &= 0.17 \times \left(\frac{80}{140 + 80} \right) + 0.83 = 0.89 \end{aligned} \right\} C = 0.89 \times 0.88 = 0.78$$

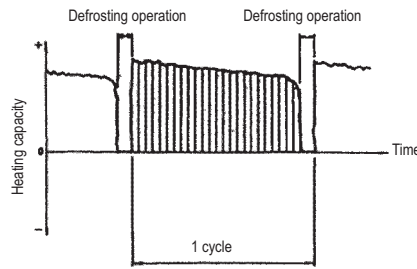

Please note that, when there is an accumulation of snow against the outside surface of the outdoor unit heat exchanger, there will always be a temporary reduction in capacity, although this will of course vary in degree in accordance with a number of other factors, such as the outdoor temperature (°CDB), relative humidity (RH) and the amount of frosting which occurs.

3TW33912-5

NOTE

The figure shows that the integrated heating capacity expresses the integrated capacity for a single cycle (from defrost operation to defrost operation) in terms of time.

4 Capacity tables

4 - 4 Capacity Correction Factor

RXYRQ8P

Correction ratio for cooling capacity

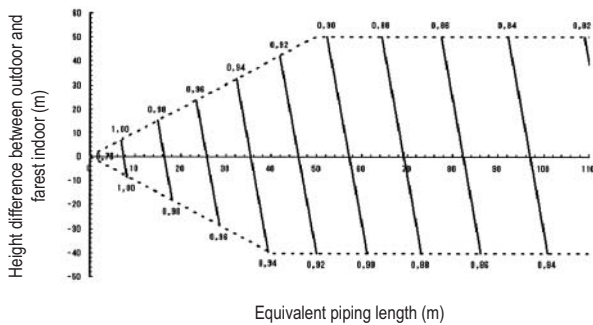

Correction ratio for heating capacity

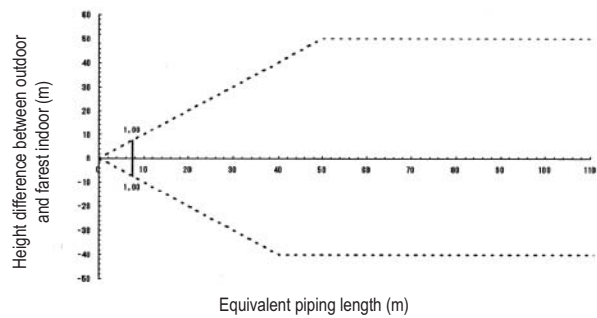

[Diameter of the main pipes (standard size)]

Model	Gas pipe	Liquid pipe
RXYRQ8P	19.1	9.5

3TW31472-1B

NOTES

- These figures illustrate the correction ratio for piping length in capacity for a standard indoor unit system at maximum load (with the thermostat set to maximum) under standard conditions. Moreover, under partial load conditions, there is only a minor deviation for the capacity correction ratio, shown in the above figures.
- With this outdoor unit, constant evaporating pressure control when cooling and constant condensing pressure control when heating is carried out.
- Method of calculating the capacity of the outdoor units:
The maximum capacity of the system will be either the total capacity of the indoor units or the maximum capacity of the outdoor units as mentioned below, whichever is smaller.
- Condition: Indoor connection ratio does not exceed 100%.

$$\text{Maximum capacity of outdoor units} = \text{Capacity of outdoor units from capacity table at 100\% connection ratio} \times \text{Correction ratio of piping to furthest indoor}$$

- Condition: Indoor connection ratio exceeds 100%.

$$\text{Maximum capacity of outdoor units} = \text{Capacity of outdoor units from capacity table at installed connection ratio} \times \text{Correction ratio of piping to furthest indoor}$$

- When level difference is 50m or more (maximum 50m for RXYRQ models) and equivalent pipe length is 90m or more, the diameter of the main gas and liquid pipes (outdoor unit - branch sections) must be increased. For new diameters, see below.

Model	Gas pipe	Liquid pipe
RXYRQ8P	22.2	12.7

- When the pipe length after the first refrigerant branch kit is more than 40m, pipe size between first and final branch kit must be increased (refer also to installation manual). For the RXYRQ models a liquid/gas pipe size up is required when the pipe length after the first refrigerant branch kit is more than 20m or 30m. For a detailed explanation refer to the installation manual.
- Equivalent length used in the above figures is based upon the following equivalent length.

$$\text{Equivalent piping length} = \text{Equivalent length of main pipe} \times \text{Correction factor} + \text{Equivalent length of branch pipes}$$

Choose the correction factor from the following table. [When cooling capacity is calculated: gas pipe size
When heating capacity is calculated: liquid pipe size

	Correction factor	
	Standard size	Size increase
Cooling (gas pipe)	1.0	0.5
Heating (liquid pipe)	1.0	0.5

(example)

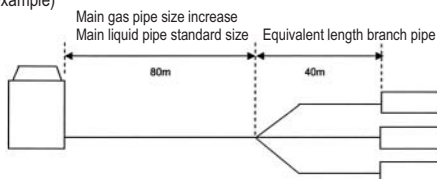

In the above case (Cooling) Overall equivalent length = 80m x 0.5 + 40m = 80m
(Heating) Overall equivalent length = 80m x 0.5 + 40m = 80m
The rate of change in cooling capacity when height difference = 0 is thus approximately 0.86
heating capacity when height difference = 0 is thus approximately 1.0

4 Capacity tables

4 - 4 Capacity Correction Factor

RXYRQ10P

Correction factor for cooling capacity

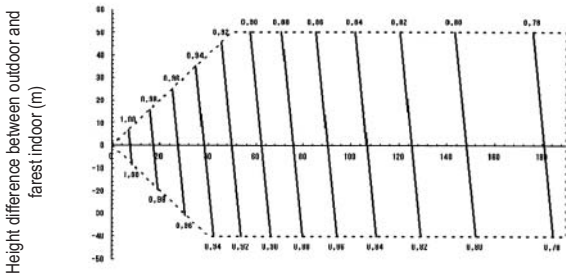

Correction factor for heating capacity

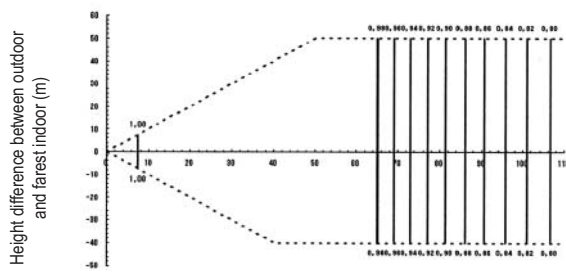

Equivalent piping length (m)

Equivalent piping length (m)

[Diameter of the main pipes (standard size)]

Model	Gas pipe	Liquid pipe
RXYRQ10P	22.2	9.5

3TW31472-1B

NOTES

- These figures illustrate the correction ratio for piping length in capacity for a standard indoor unit system at maximum load (with the thermostat set to maximum) under standard conditions. Moreover, under partial load conditions, there is only a minor deviation for the capacity correction ratio, shown in the above figures.
- With this outdoor unit, constant evaporating pressure control when cooling and constant condensing pressure control when heating is carried out.
- Method of calculating the capacity of the outdoor units:
The maximum capacity of the system will be either the total capacity of the indoor units or the maximum capacity of the outdoor units as mentioned below, whichever is smaller.
- Condition: Indoor connection ratio does not exceed 100%.

Maximum capacity of outdoor units = Capacity of outdoor units from capacity table at 100% connection ratio
x Correction ratio of piping to furthest indoor

- Condition: Indoor connection ratio exceeds 100%.

Maximum capacity of outdoor units = Capacity of outdoor units from capacity table at installed connection ratio
x Correction ratio of piping to furthest indoor

- When level difference is 50m (maximum 50m for RXYRQ models) or more and equivalent pipe length is 90m or more, the diameter of the main gas and liquid pipes (outdoor unit - branch sections) must be increased. For new diameters, see below.

Model	Gas pipe	Liquid pipe
RXYRQ10P	25.4*	12.7

* If not available on site, do not increase. If not increased, no correction factor should be applied to the equivalent length (see note 6).

- When the pipe length after the first refrigerant branch kit is more than 40m, pipe size between first and final branch kit must be increased (refer also to installation manual). For the RXYRQ models a liquid/gas pipe size up is required when the pipe length after the first refrigerant branch kit is more than 20m or 30m. For a detailed explanation refer to the installation manual.
- Equivalent length used in the above figures is based upon the following equivalent length.

Equivalent piping length = Equivalent length of main pipe x Correction factor + Equivalent length of branch pipes

Choose the correction factor from the following table. [When cooling capacity is calculated: gas pipe size
[When heating capacity is calculated: liquid pipe size

	Correction factor	
	Standard size	Size increase
Cooling (gas pipe)	1.0	0.5
Heating (liquid pipe)	1.0	0.5

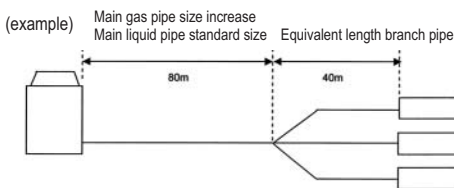

In the above case (Cooling) Overall equivalent length = 80m x 0.5 + 40m = 80m
(Heating) Overall equivalent length = 80m x 0.5 + 40m = 80m
The rate of change in cooling capacity when height difference = 0 is thus approximately 0.87
heating capacity when height difference = 0 is thus approximately 0.90

4 Capacity tables

4 - 4 Capacity Correction Factor

RXYRQ12-14P

Correction ratio for cooling capacity

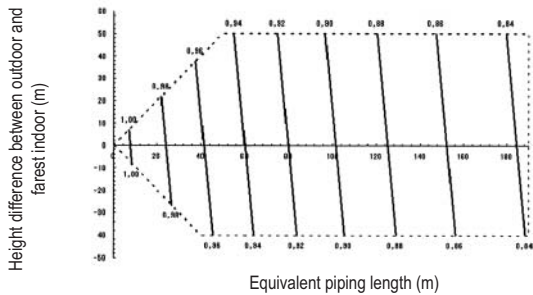

Correction ratio for heating capacity

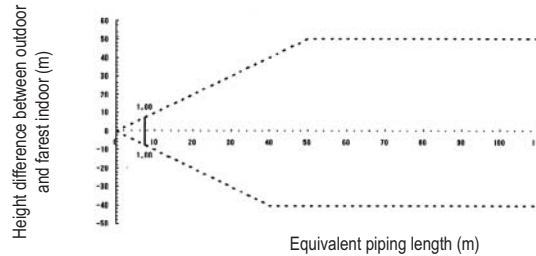

[Diameter of the main pipes (standard size)]

Model	Gas pipe	Liquid pipe
RXYRQ12P	28.6	12.7
RXYRQ14P	28.6	12.7

3TW31472-1B

NOTES

- These figures illustrate the correction ratio for piping length in capacity for a standard indoor unit system at maximum load (with the thermostat set to maximum) under standard conditions. Moreover, under partial load conditions, there is only a minor deviation for the capacity correction ratio, shown in the above figures.
- With this outdoor unit, constant evaporating pressure control when cooling and constant condensing pressure control when heating is carried out.
- Method of calculating the capacity of the outdoor units:
The maximum capacity of the system will be either the total capacity of the indoor units or the maximum capacity of the outdoor units as mentioned below, whichever is smaller.
- Condition: Indoor connection ratio does not exceed 100%.

$$\text{Maximum capacity of outdoor units} = \text{Capacity of outdoor units from capacity table at 100\% connection ratio} \times \text{Correction ratio of piping to furthest indoor}$$

- Condition: Indoor connection ratio exceeds 100%.

$$\text{Maximum capacity of outdoor units} = \text{Capacity of outdoor units from capacity table at installed connection ratio} \times \text{Correction ratio of piping to furthest indoor}$$

- When level difference is 50m or more (maximum 50m for RXYRQ models) and equivalent pipe length is 90m or more, the diameter of the main gas and liquid pipes (outdoor unit - branch sections) must be increased. For new diameters, see below.

Model	Gas pipe	Liquid pipe
RXYRQ12P	28.6	15.9
RXYRQ14P	28.6	15.9

- When the pipe length after the first refrigerant branch kit is more than 40m, pipe size between first and final branch kit must be increased (refer also to installation manual). For the RXYRQ models a liquid/gas pipe size up is required when the pipe length after the first refrigerant branch kit is more than 20m or 30m. For a detailed explanation refer to the installation manual.
- Equivalent length used in the above figures is based upon the following equivalent length.

$$\text{Equivalent piping length} = \text{Equivalent length of main pipe} \times \text{Correction factor} + \text{Equivalent length of branch pipes}$$

Choose the correction factor from the following table. [When cooling capacity is calculated: gas pipe size
When heating capacity is calculated: liquid pipe size]

	Correction factor	
	Standard size	Size increase
Cooling (gas pipe)	1.0	
Heating (liquid pipe)	1.0	0.5

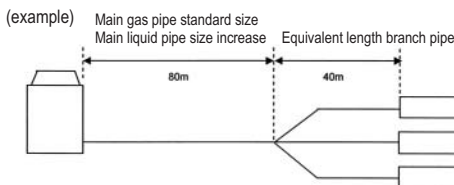

In the above case (Cooling) Overall equivalent length = 80m x 1.0 + 40m = 120m
(Heating) Overall equivalent length = 80m x 0.5 + 40m = 80m
The rate of change in cooling capacity when height difference = 0 is thus approximately 0.89
heating capacity when height difference = 0 is thus approximately 1.0

4 Capacity tables

4 - 4 Capacity Correction Factor

RXYRQ16P

Correction ratio for cooling capacity

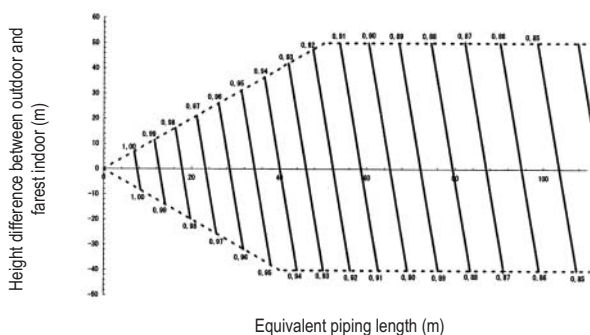

Correction ratio for heating capacity

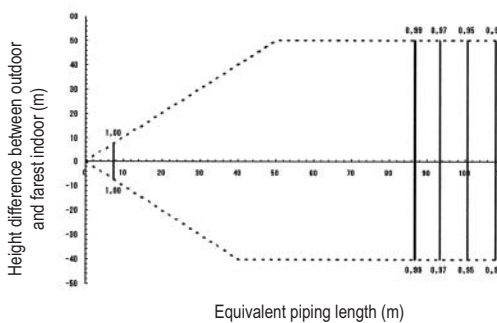

[Diameter of the main pipes (standard size)]

Model	Gas pipe	Liquid pipe
RXYRQ16P	28.6	12.7

3TW31472-1B

NOTES

- These figures illustrate the correction ratio for piping length in capacity for a standard indoor unit system at maximum load (with the thermostat set to maximum) under standard conditions. Moreover, under partial load conditions, there is only a minor deviation for the capacity correction ratio, shown in the above figures.
- With this outdoor unit, constant evaporating pressure control when cooling and constant condensing pressure control when heating is carried out.
- Method of calculating the capacity of the outdoor units:
The maximum capacity of the system will be either the total capacity of the indoor units or the maximum capacity of the outdoor units as mentioned below, whichever is smaller.
- Condition: Indoor connection ratio does not exceed 100%.

$$\text{Maximum capacity of outdoor units} = \text{Capacity of outdoor units from capacity table at 100\% connection ratio} \times \text{Correction ratio of piping to furthest indoor}$$

- Condition: Indoor connection ratio exceeds 100%.

$$\text{Maximum capacity of outdoor units} = \text{Capacity of outdoor units from capacity table at installed connection ratio} \times \text{Correction ratio of piping to furthest indoor}$$

- When level difference is 50m (maximum 50m for RXYRQ models) or more and equivalent pipe length is 90m or more, the diameter of the main gas and liquid pipes (outdoor unit - branch sections) must be increased. For new diameters, see below.

Model	Gas pipe	Liquid pipe
RXYRQ16P	31.8*	15.9

* If not available on site, do not increase. If not increased, no correction factor should be applied to the equivalent length (see note 6).

- When the pipe length after the first refrigerant branch kit is more than 40m, pipe size between first and final branch kit must be increased (refer also to installation manual). For the RXYRQ models a liquid/gas pipe size up is required when the pipe length after the first refrigerant branch kit is more than 20m or 30m. For a detailed explanation refer to the installation manual.
- Equivalent length used in the above figures is based upon the following equivalent length.

$$\text{Overall Equivalent length} = \text{Equivalent length of main pipe} \times \text{Correction factor} + \text{Equivalent length of branch pipes}$$

Choose the correction factor from the following table. [When cooling capacity is calculated: gas pipe size
[When heating capacity is calculated: liquid pipe size

	Correction factor	
	Standard size	Size increase
Cooling (gas pipe)	1.0	0.5
Heating (liquid pipe)	1.0	0.5

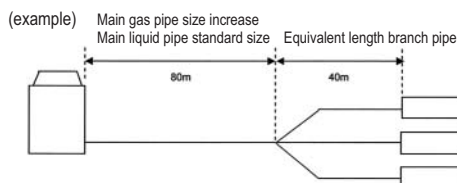

In the above case (Cooling) Overall equivalent length = 80m x 0.5 + 40m = 80m
(Heating) Overall equivalent length = 80m x 0.5 + 40m = 80m
The rate of change in cooling capacity when height difference = 0 is thus approximately 0.88
heating capacity when height difference = 0 is thus approximately 0.99

4 Capacity tables

4 - 4 Capacity Correction Factor

RXYRQ18P

Correction ratio for cooling capacity

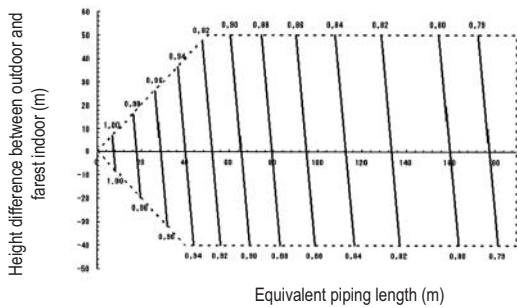

Correction ratio for heating capacity

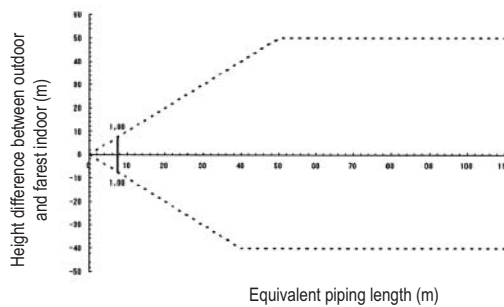

[Diameter of the main pipes (standard size)]

Model	Gas pipe	Liquid pipe
RXYRQ18P	28.6	15.9

3TW31472-1B

NOTES

- These figures illustrate the correction ratio for piping length in capacity for a standard indoor unit system at maximum load (with the thermostat set to maximum) under standard conditions. Moreover, under partial load conditions, there is only a minor deviation for the capacity correction ratio, shown in the above figures.
- With this outdoor unit, constant evaporating pressure control when cooling and constant condensing pressure control when heating is carried out.
- Method of calculating the capacity of the outdoor units:
The maximum capacity of the system will be either the total capacity of the indoor units or the maximum capacity of the outdoor units as mentioned below, whichever is smaller.
- Condition: Indoor connection ratio does not exceed 100%.

$$\text{Maximum capacity of outdoor units} = \text{Capacity of outdoor units from capacity table at 100\% connection ratio} \times \text{Correction ratio of piping to furthest indoor}$$

- Condition: Indoor connection ratio exceeds 100%.

$$\text{Maximum capacity of outdoor units} = \text{Capacity of outdoor units from capacity table at installed connection ratio} \times \text{Correction ratio of piping to furthest indoor}$$

- When level difference is 50m or more (maximum 50m for RXYRQ models) and equivalent pipe length is 90m or more, the diameter of the main gas and liquid pipes (outdoor unit - branch sections) must be increased. For new diameters, see below.

Model	Gas pipe	Liquid pipe
RXYRQ18P	31.8*	19.1

* If not available on site, do not increase. If not increased, no correction factor should be applied to the equivalent length (see note 6).

- When the pipe length after the first refrigerant branch kit is more than 40m, pipe size between first and final branch kit must be increased (refer also to installation manual). For the RXYRQ models a liquid/gas pipe size up is required when the pipe length after the first refrigerant branch kit is more than 20m or 30m. For a detailed explanation refer to the installation manual.
- Equivalent length used in the above figures is based upon the following equivalent length.

$$\text{Equivalent piping length} = \text{Equivalent length of main pipe} \times \text{Correction factor} + \text{Equivalent length of branch pipes}$$

Choose the correction factor from the following table. [When cooling capacity is calculated: gas pipe size
When heating capacity is calculated: liquid pipe size]

	Correction factor	
	Standard size	Size increase
Cooling (gas pipe)	1.0	0.5
Heating (liquid pipe)	1.0	0.5

(example) Main gas pipe standard size
Main liquid pipe size increase Equivalent length branch pipe

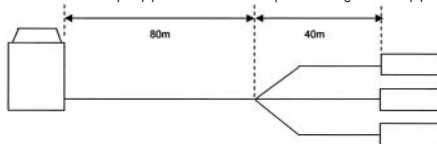

In the above case (Cooling) Overall equivalent length = 80m x 1.0 + 40m = 120m
(for RXYQ38-44) (Heating) Overall equivalent length = 80m x 0.5 + 40m = 80m
The rate of change in cooling capacity when height difference = 0 is thus approximately 0.83
heating capacity when height difference = 0 is thus approximately 1.0

5 Dimensional drawings

5 - 1 Dimensional Drawings

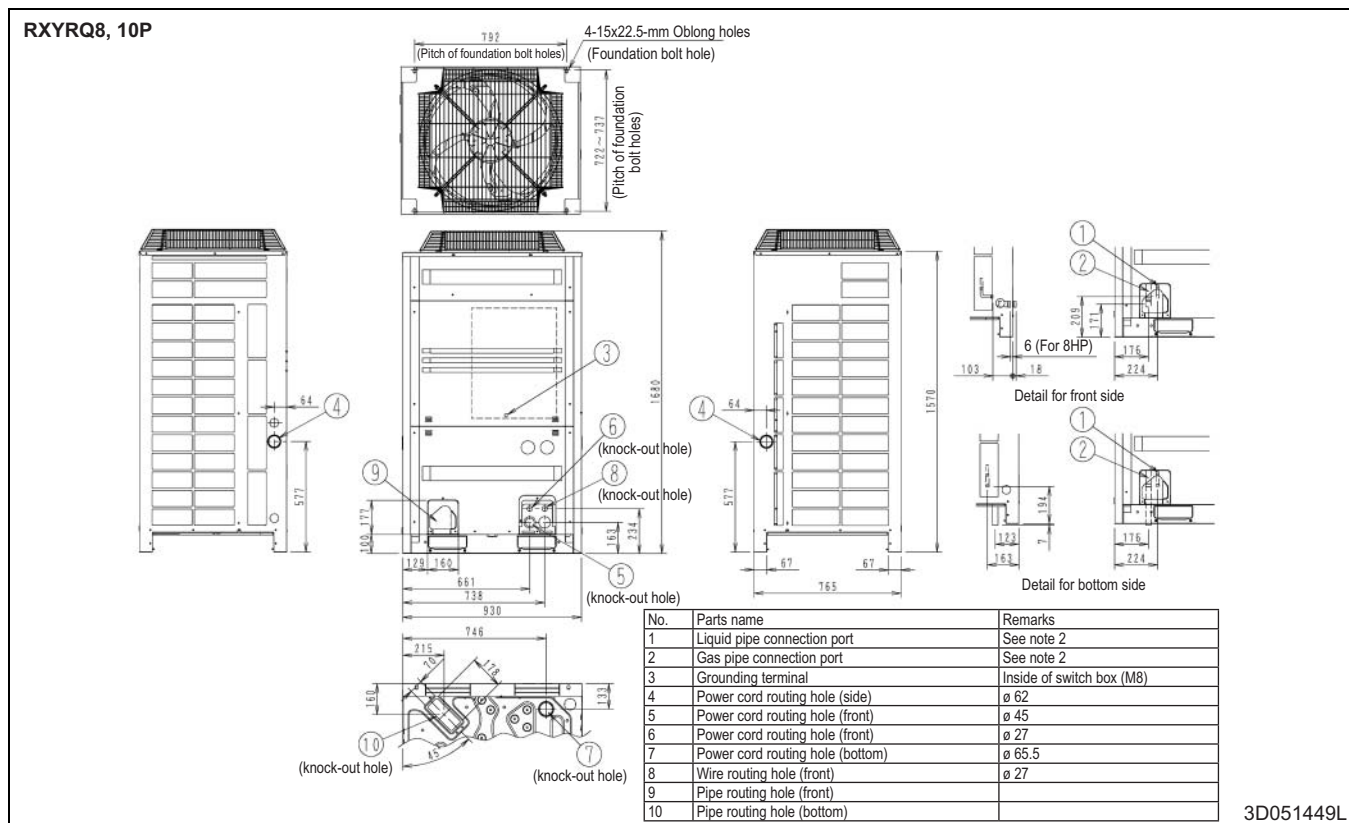

NOTES

- Detail for front side and detail for bottom side indicate the dimensions after fixing the attached piping
- Gas pipe [Heat pump type] ø 19.1 Brazing connection RXYRQ8P type
ø 22.2 Brazing connection RXYRQ10P type
Liquid pipe [Heat pump type] ø 9.5 Brazing connection RXYRQ8,10P type

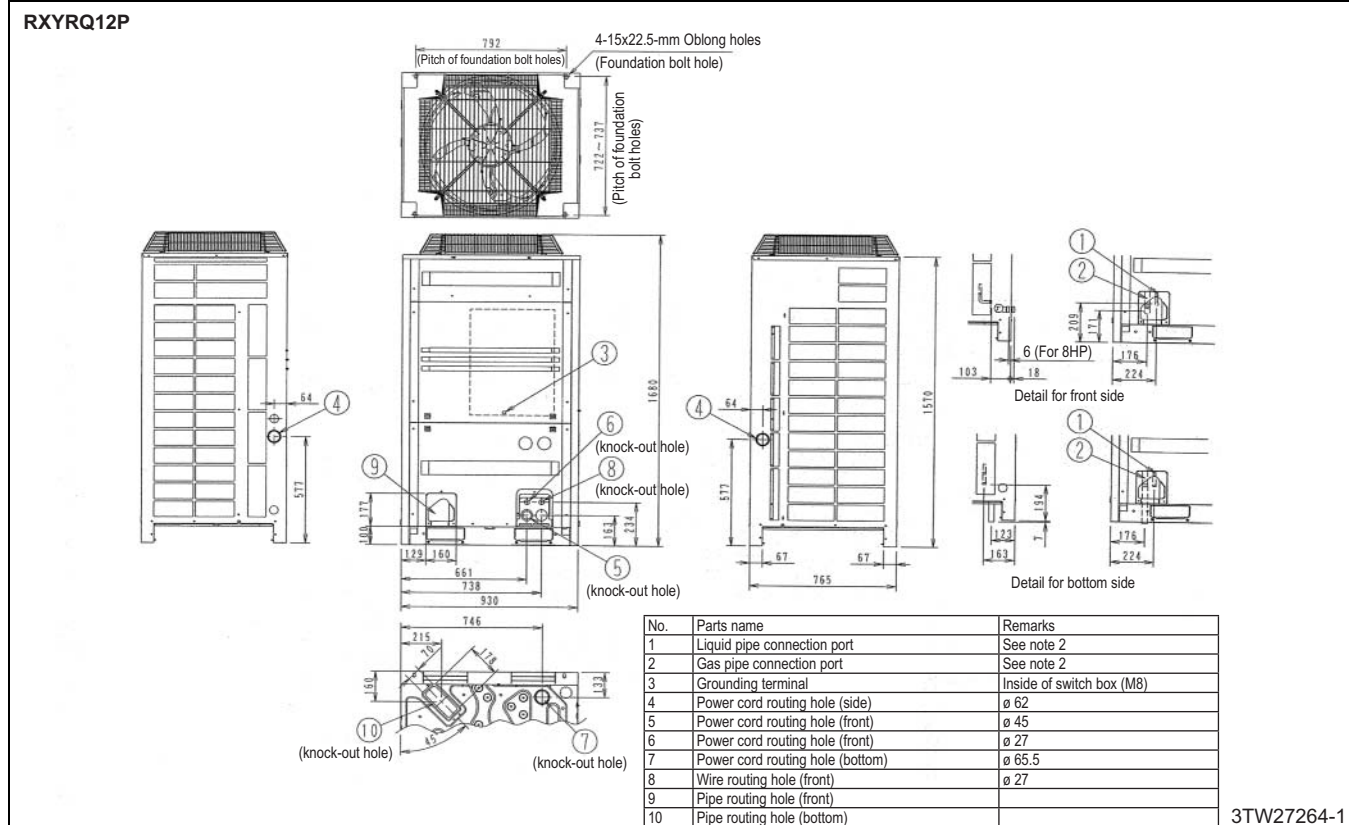

NOTES

- Detail for front side and detail for bottom side indicate the dimensions after fixing the attached piping
- Gas pipe [Heat pump type] ø 28.6 Brazing connection***12P type
Liquid pipe [Heat pump type] ø 12.7 Brazing connection***12P type

5 Dimensional drawings

5 - 1 Dimensional Drawings

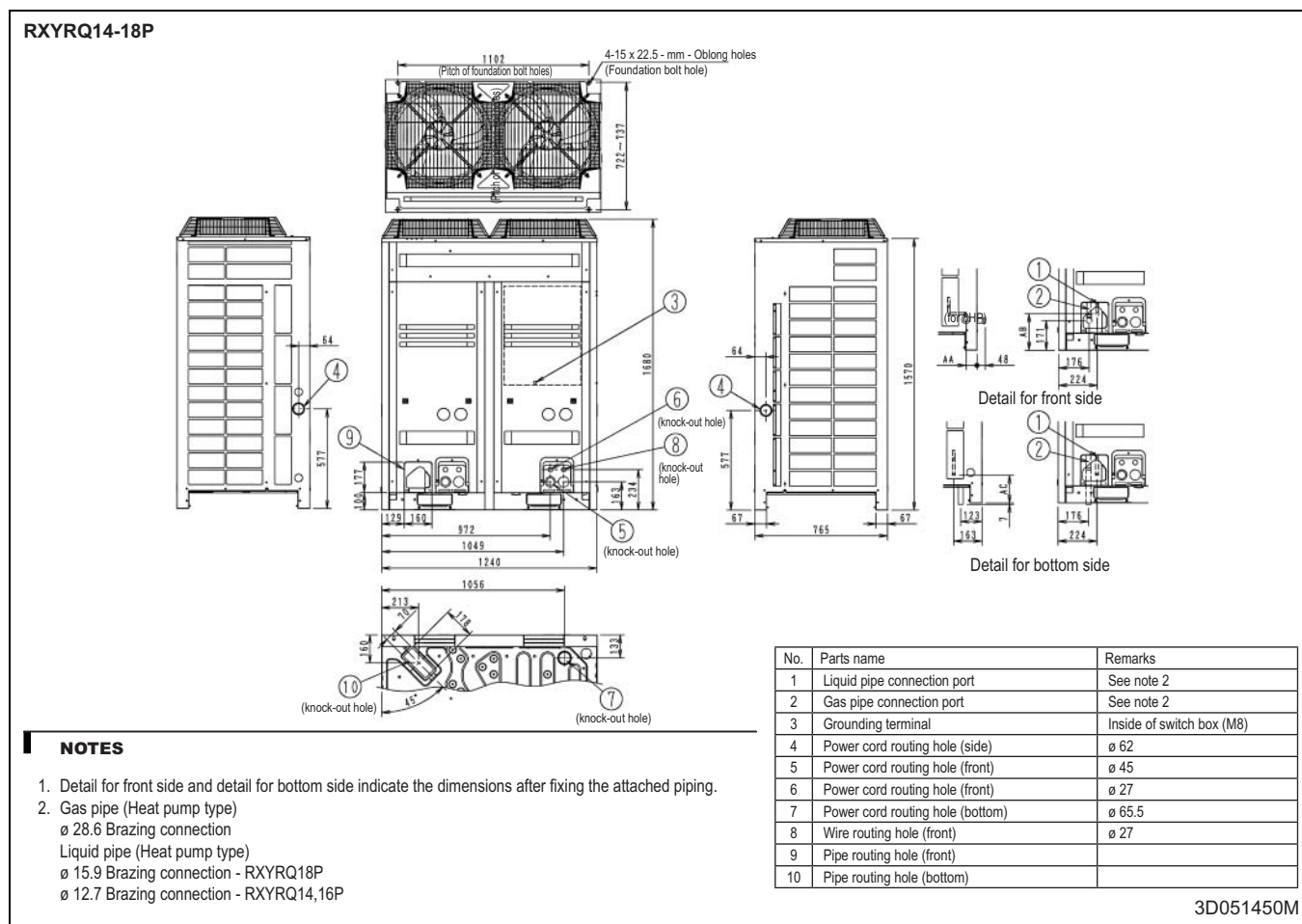

5 Dimensional drawings

5 - 2 Dimensional Drawings with Accessories

RXYRQ8-12P

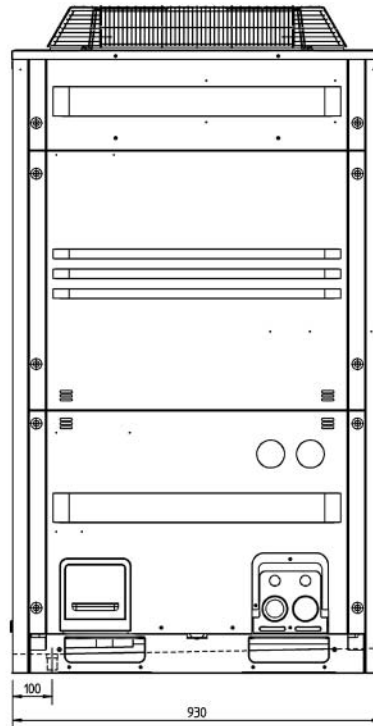
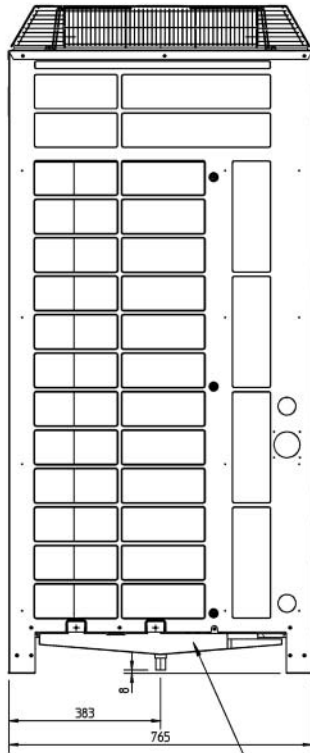

Item	Parts name	Remark
1	Central drain pan kit	KWC26B280

3TW27244-1

RXYRQ14-18P

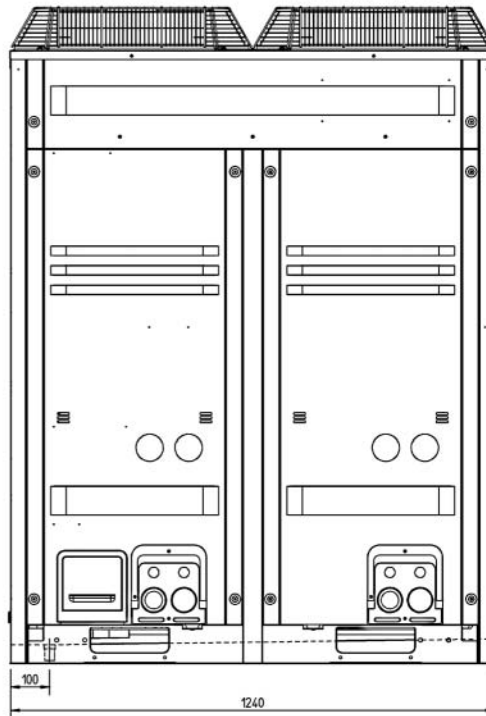
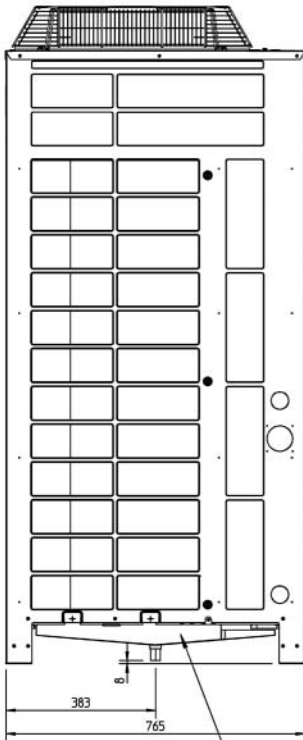

Item	Parts name	Remark
1	Central drain pan kit	KWC26B450

3TW27274-1

6 Centre of gravity

6 - 1 Centre of Gravity

RXYRQ8P

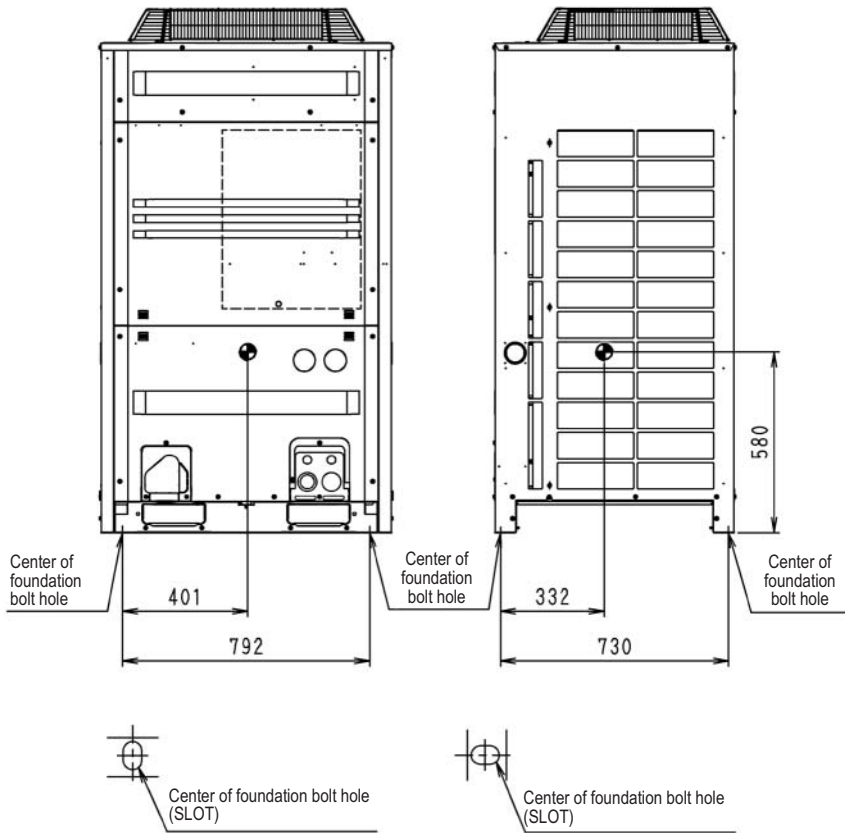

4D052146L

RXYRQ10,12P

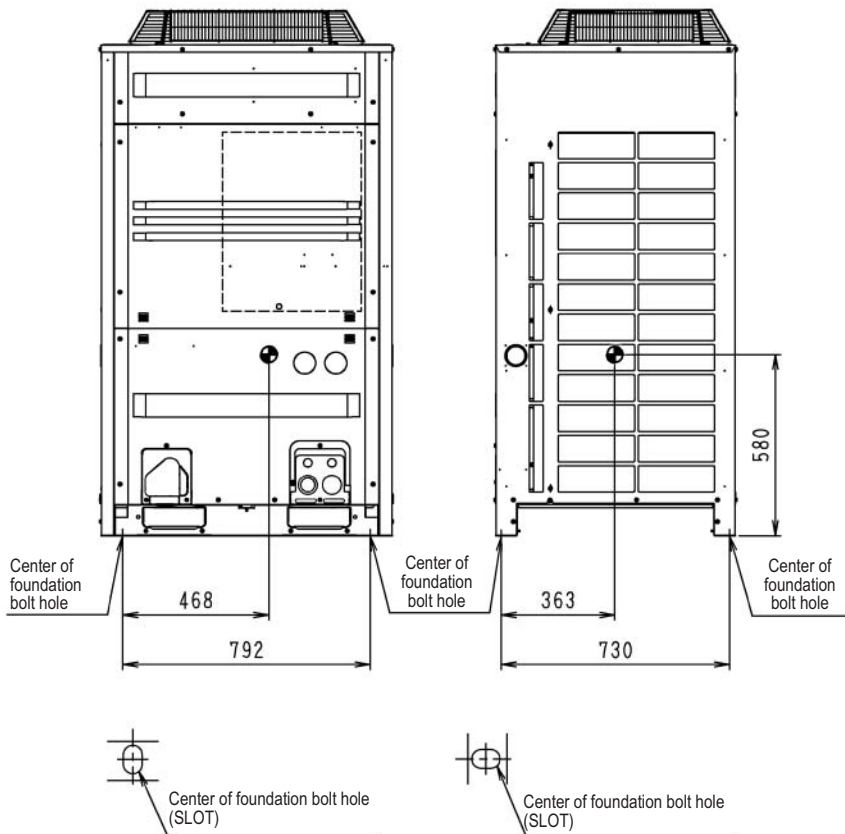

4D052147J

6 Centre of gravity

6 - 1 Centre of Gravity

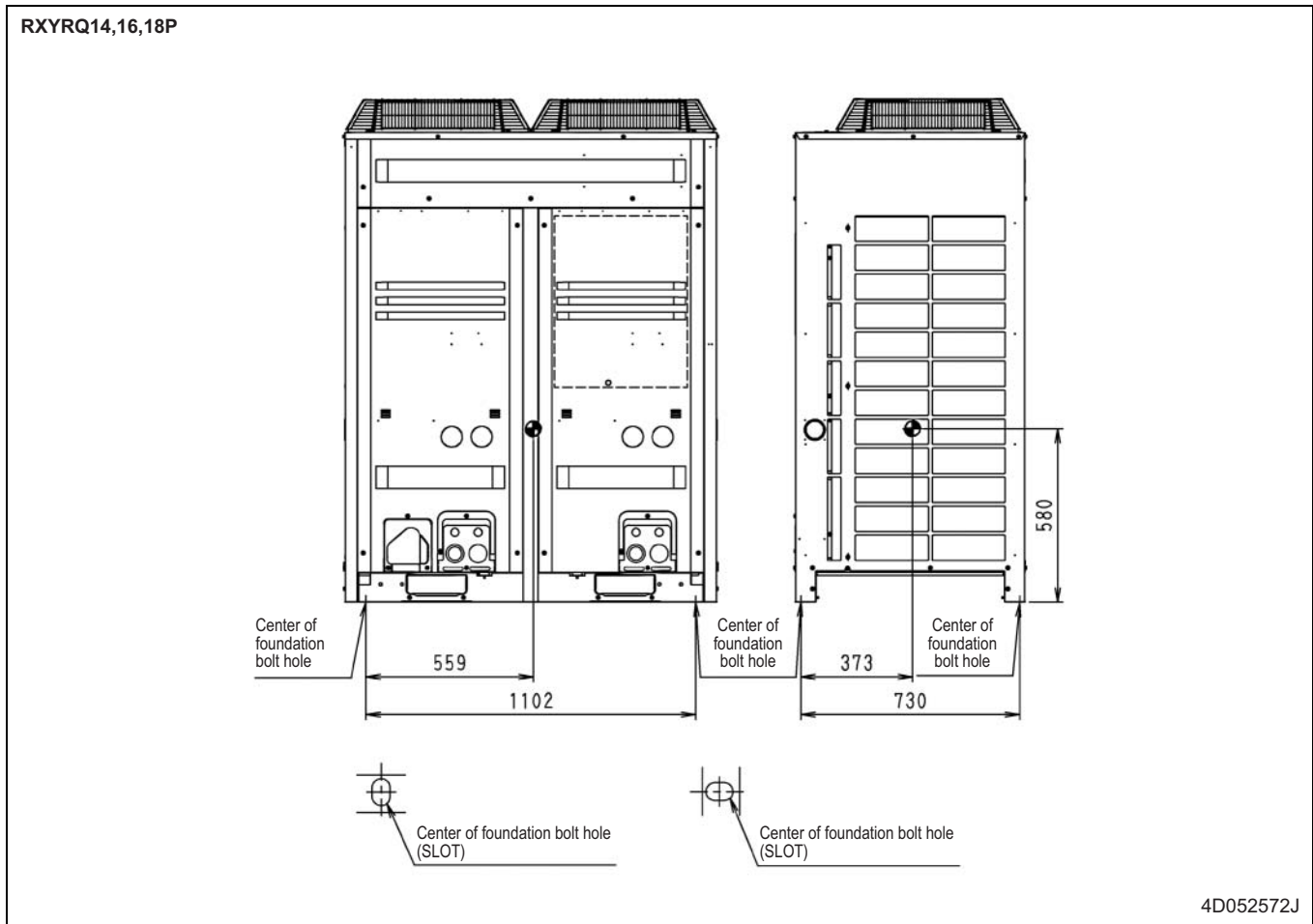

7 Piping diagrams

7 - 1 Piping Diagrams

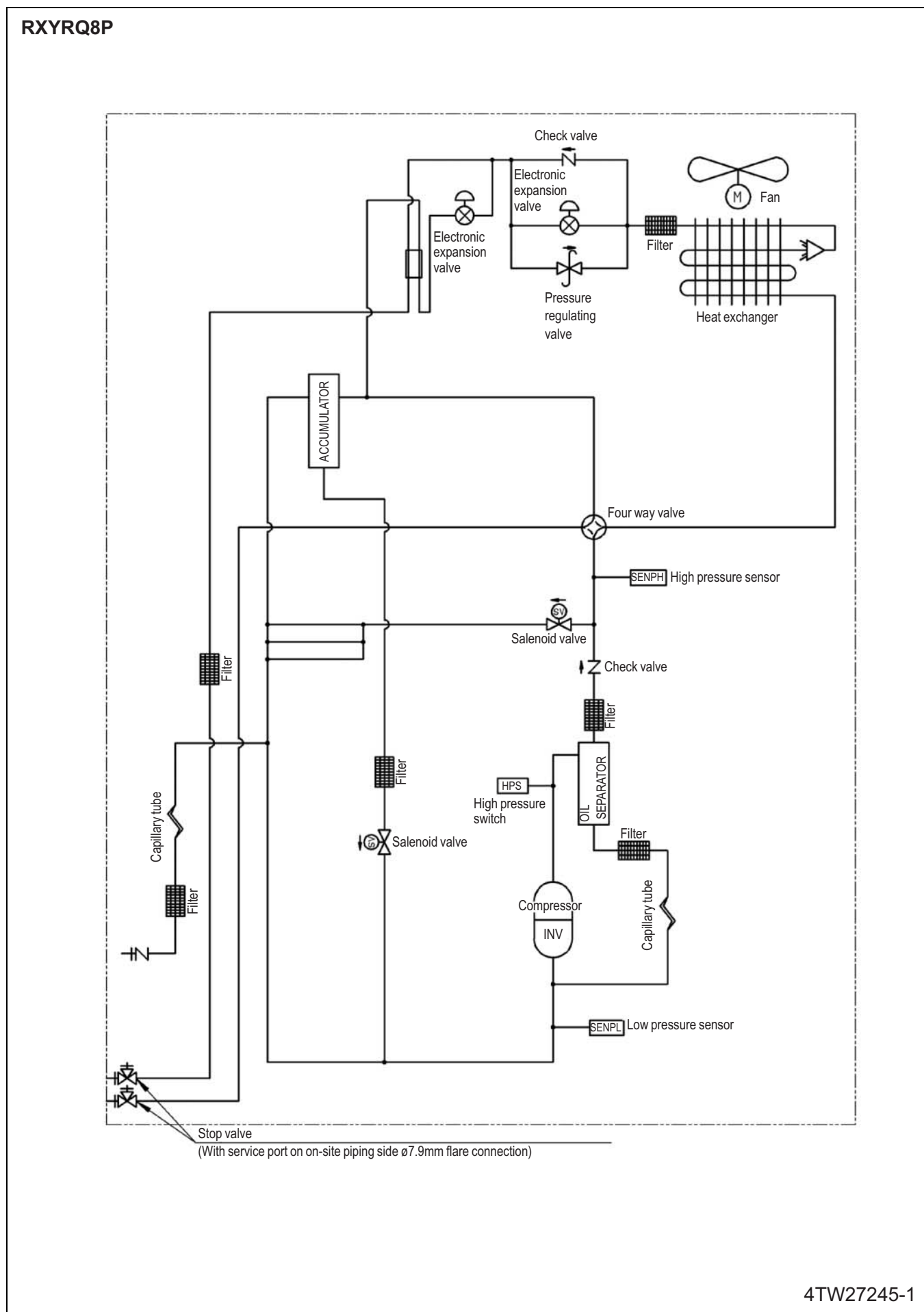

7 Piping diagrams

7 - 1 Piping Diagrams

RXYRQ10,12P

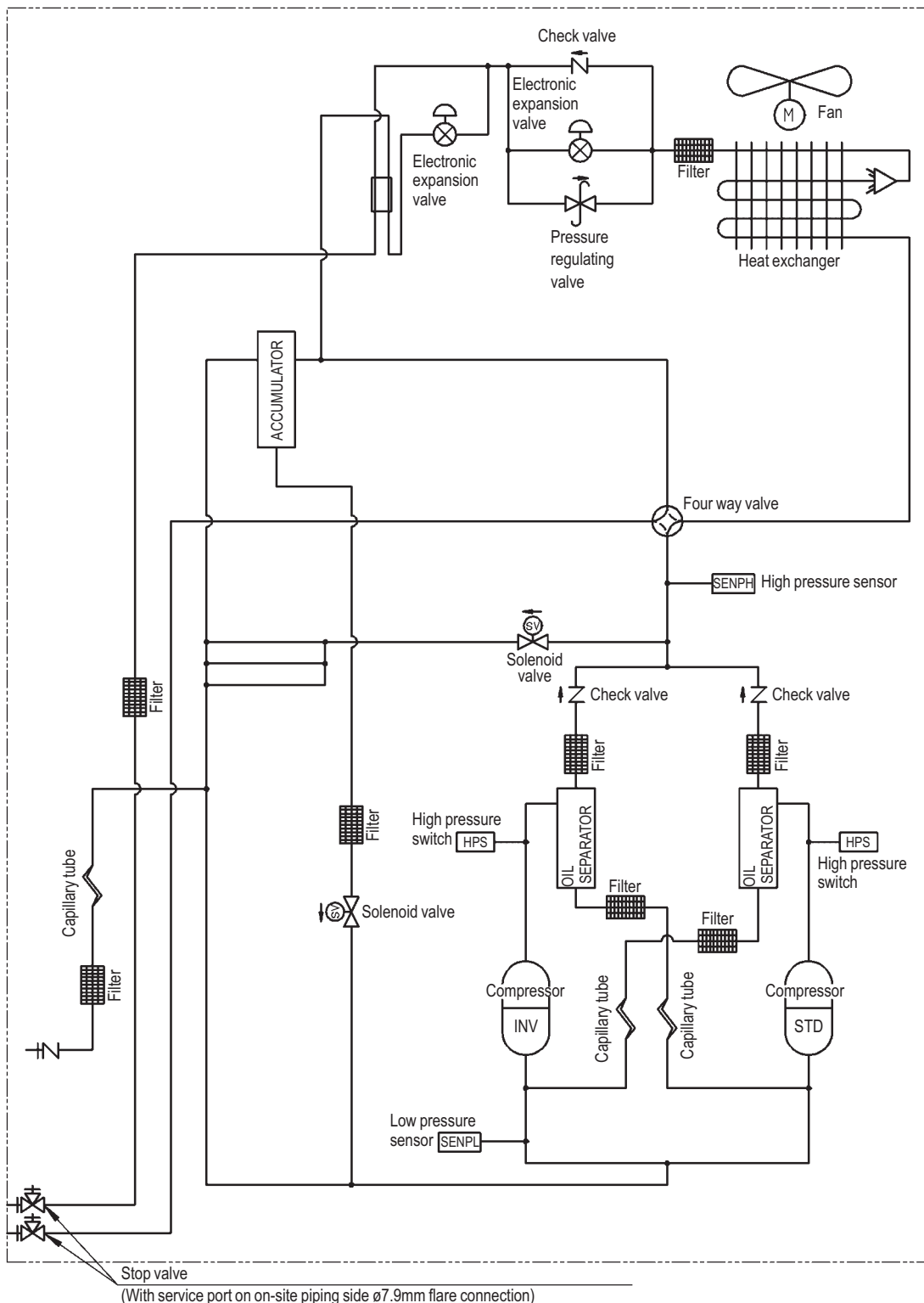

4TW27255-1

7 Piping diagrams

7 - 1 Piping Diagrams

RXYRQ14-18P

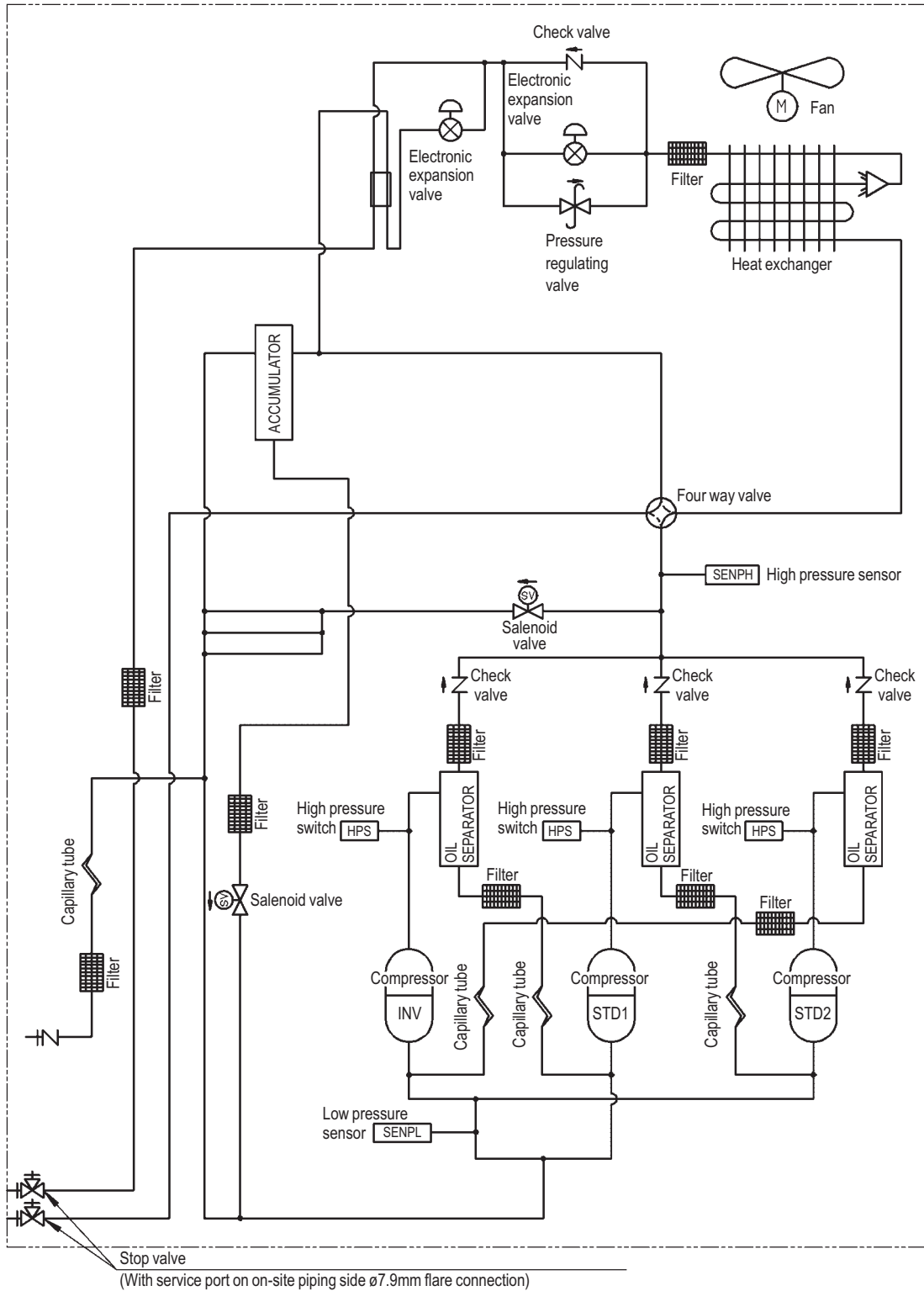

4TW27275-1

8 Wiring diagrams

8 - 1 Wiring Diagrams - Three Phase

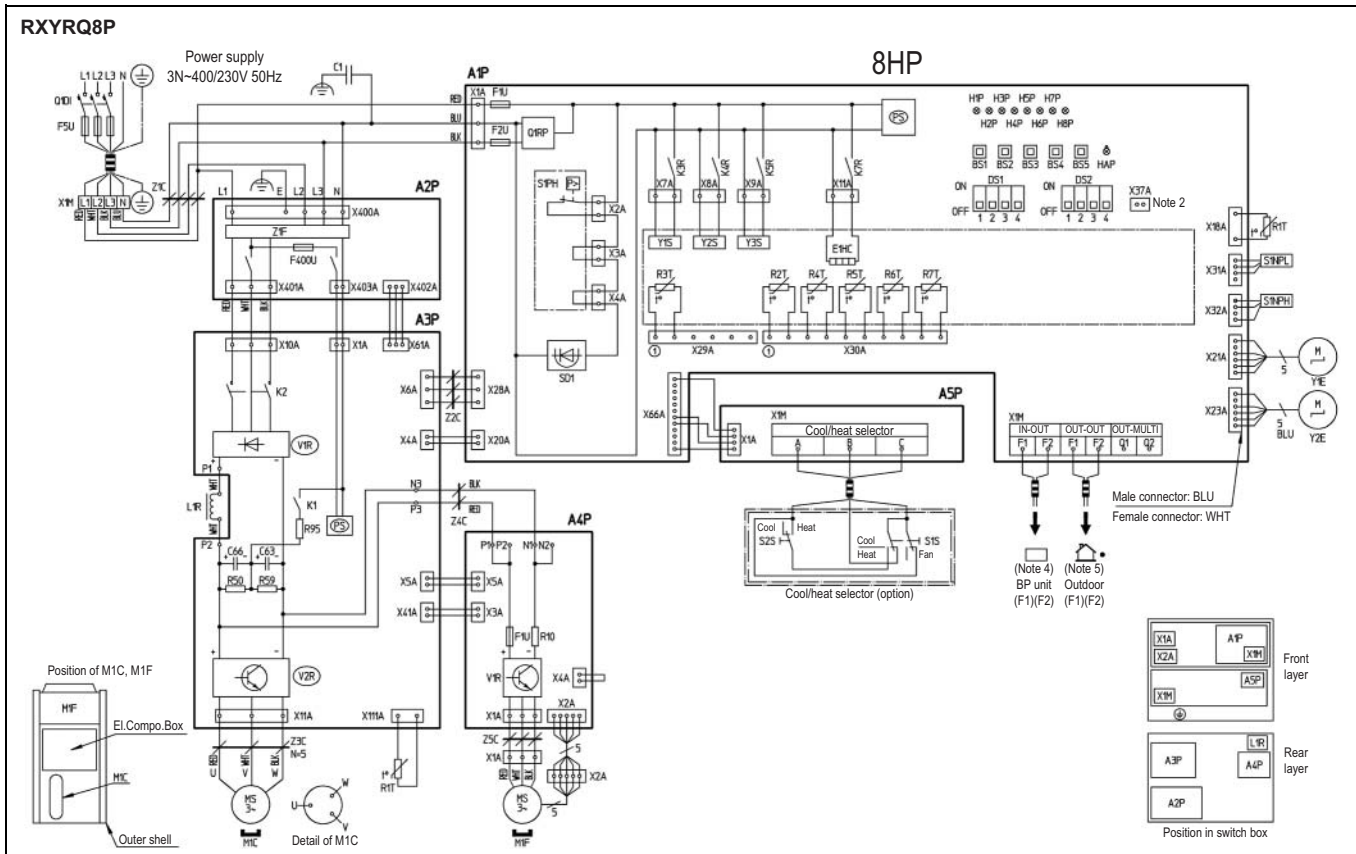

A1P A5P	Printed circuit board	K3R	Y1S	S1NPL	Pressure sensor (Low)	
	A1P Main	K4R	Y2S	S1PH, S2PH	Pressure switch (High)	
	A2P Noise filter	K5R	Y3S			
	A3P Inverter	K7R	E1HC	SD1	Safety devices input	
	A4P Fan	L1R	Reactor	V1R, V2R	Power module (A4P)	
BS1~BS5	Push button switch (Mode, set, return, test, reset)	M1F	Motor Fan	X1A, X2A	Connector (M1F)	
		PS	Switching Power supply (A1P, A3P)	X1M	Terminal strip (power supply)	
C1	Capacitor	Q1RP	Phase reversal detect circuit	X1M	Terminal strip (control) (A1P)	
C63, C66	Capacitor	Q1DI	Earth leakage breaker	X1M	Terminal strip (A5P)	
DS1, DS2	Dip Switch	R10	Resistor (current sensor) (A4P)	Y1E	Electronic expansion valve (main)	
E1HC	Crankcase heater	R50, R59	Resistor	Y2E	Electronic expansion valve (subcool)	
F1U, F2U	Fuse (250V, 8A Ⓟ)(A4P)	R1T~R7T	R95	Resistor (current limiting)	Solenoid valve	
F5U	Fuse (250V, 3.15A Ⓟ)(A1P)		R1T	Air (A1P)	Y1S	Hot gas
F400U	Fuse (250V, 6.3A Ⓟ)(A2P)		R1T	Fin (A3P)	Y2S	Oil return
H1P~H8P	Pilotlamp (service monitor - orange) [H2P] prepare test.....Flickering Malfunction detection.....Light up		R2T	Suction	Y3S	4 way valve
			R3T	M1C Discharge	Z1C~5C	Noise filter (ferrite core)
			R4T	Heat exch. deicer	Z1F	Noise filter (with surge absorber)
HAP	Pilotlamp (service monitor - green)		R5T	Heat exch. outlet		
K1	Magnetic relay	R6T	Liquid pipe		Cool/heat selector	
K2	Magnetic contactor (M1C)	R7T	Accumulator	S1S	Selector switch (fan / cool - heat)	
		S1NPH	Pressure sensor (High)	S2S	Selector switch (cool-heat)	

BLK	Black	RED	Red	BLU	Blue	WHT	White	PNK	Pink
BRN	Brown	GRY	Grey	GRN	Green	ORG	Orange	YLW	Yellow
	Field wiring		Terminal strip		Connector		Terminal		Protective earth (screw)

NOTES

- This wiring diagram only applies to the outdoor unit.
- When using the option adapter, refer to the installation manual.
- Do not operate the unit by short-circuiting protection device S1PH.
- Refer to the installation manual for connecting wiring to BP-outdoor transmission F1-F2.
- When using the central control system, connect outdoor-outdoor transmission F1-F2.

8 Wiring diagrams

8 - 1 Wiring Diagrams - Three Phase

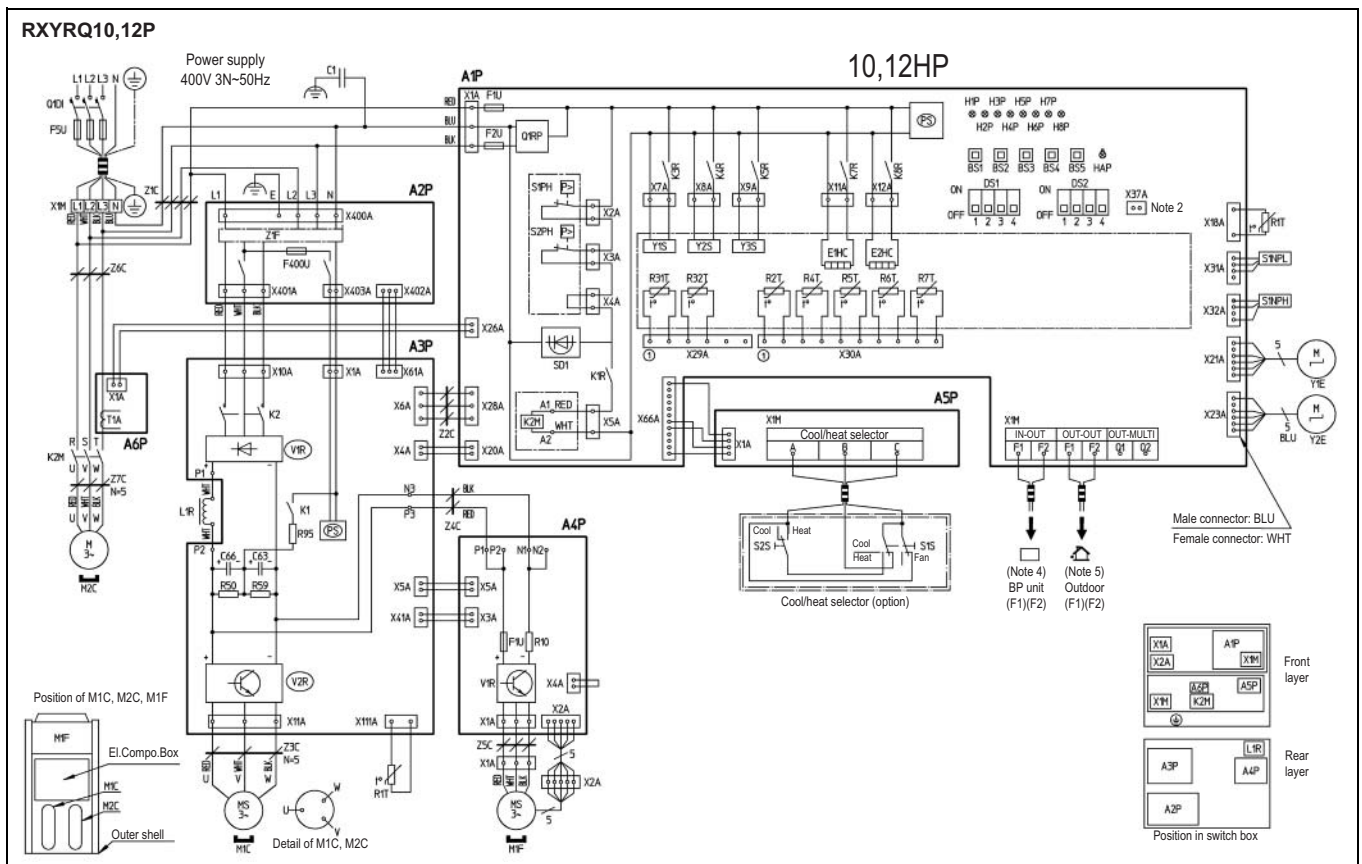

A1P - A6P	Printed circuit board	K1R	Magnetic relays (K2M)	S1NPH	Pressure sensor (High)				
	A1P	Main	K3R	Y1S	S1NPL	Pressure sensor (Low)			
	A2P	Noise filter	K4R	Y2S	S1PH, S2PH	Pressure switch (High)			
	A3P	Inverter	K5R	Y3S	T1A	Current sensor (A6P)			
	A4P	Fan	K7R	E1HC	SD1	Safety devices input			
	A5P	ABC I/P	K8R	E2HC	V1R	Power module (A4P)			
	A6P	Current sensor	L1R	Reactor	V1R, V2R	Power module (A3P)			
BS1-BS5	Push button switch (Mode, set, return, test, reset)	M1C, M2C	Motor (compressor)	X1A, X2A	Connector (M1F)				
		M1F	Motor Fan	X1M	Terminal strip (power supply)				
C1	Capacitor	PS	Switching Power supply (A1P, A3P)	X1M	Terminal strip (control) (A1P)				
C63, C66	Capacitor	Q1RP	Phase reversal detect circuit	X1M	Terminal strip (A5P)				
DS1, DS2	Dip Switch	Q1DI	Earth leakage breaker	Y1E	Electronic expansion valve (main)				
E1HC, E2HC	Crankcase heater	R10	Resistor (current sensor) (A4P)	Y2E	Electronic expansion valve (subcool)				
F1U	Fuse (250V, 8A Ⓢ)(A4P)	R50, R59	Resistor	Y1S-Y3S	Solenoid valve				
F1U, F2U	Fuse (250V, 3.15A Ⓢ)(A1P)	R95	Resistor (current limiting)		Y1S	Hot gas			
F5U	Field Fuse				Y2S	Oil return			
F400U	Fuse (250V, 6.3A Ⓢ)(A2P)			Y3S	4 way valve				
H1P-H8P	Pilotlamp (service monitor - orange) [H2P] prepare test..... Flickering Malfunction detection..... Light up	R1T-R7T R31T, R32T	R1T	Air (A1P)	Z1C-Z7C	Noise filter (ferrite core)			
HAP	Pilotlamp (service monitor - green)		R2T	Suction	Z1F	Noise filter (with surge absorber)			
K1	Magnetic relay		R31T	M1C Discharge	Cool/heat selector				
K2	Magnetic contactor (M1C)		R32T	M2C Discharge	S1S	Selector switch (fan / cool - heat)			
K2M	Magnetic contactor (M2C)		R4T	Heat exch. deicer	S2S	Selector switch (cool-heat)			
			R5T	Heat exch. outlet					
			R6T	Liquid pipe					
		R7T	Accumulator						
BLK	Black	RED	Red	BLU	Blue	WHT	White	PNK	Pink
BRN	Brown	GRY	Grey	GRN	Green	ORG	Orange	YLW	Yellow
	Field wiring		Terminal strip		Connector		Terminal		Protective earth (screw)

NOTES

1. This wiring diagram only applies to the outdoor unit.
2. When using the option adapter, refer to the installation manual.
3. Do not operate the unit by short-circuiting protection device S1PH.
4. Refer to the installation manual for connecting wiring to BP-outdoor transmission F1-F2.
5. When using the central control system, connect outdoor-outdoor transmission F1-F2.

8 Wiring diagrams

8 - 1 Wiring Diagrams - Three Phase

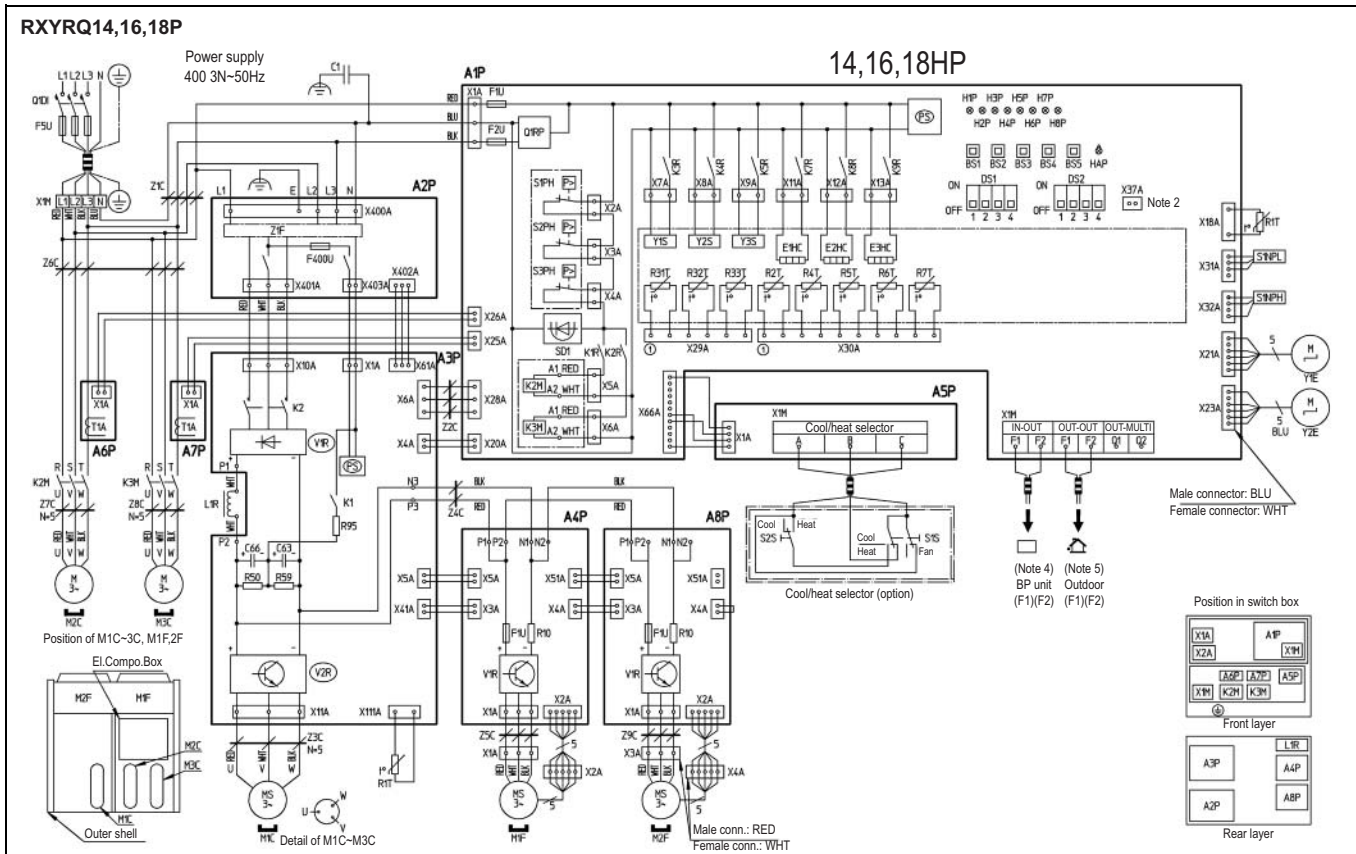

A1P - A7P	Printed circuit board	K3R	Y1S	R95	Resistor (current limiting)		
	A1P Main	K4R	Y2S	S1NPH	Pressure sensor (High)		
	A2P Noise filter	K5R	Y3S	S1NPL	Pressure sensor (Low)		
	A3P Inverter	K7R	E1HC	S1PH-S3PH	Pressure switch (High)		
	A4P, A8P Fan	K8R	E2HC	T1A	Current sensor (A6P, A7P)		
	A5P ABC I/P	K9R	E3HC	SD1	Safety devices input		
A6P, A7P	Current sensor	L1R	Reactor	V1R	Power module (A4P, A8P)		
BS1-BS5	Push button switch (Mode, set, return, test, reset)	M1C-M3C	Motor (compressor)	V1R, V2R	Power module (A3P)		
		M1F, M2F	Motor Fan	X1A-X4A	Connector (M1F)		
C1	Capacitor	PS	Switching Power supply (A1P, A3P)	X1M	Terminal strip (power supply)		
C63, C66	Capacitor	Q1RP	Phase reversal detect circuit	X1M	Terminal strip (control) (A1P)		
DS1, DS2	Dip Switch	Q1DI	Earth leakage breaker	X1M	Terminal strip (A5P)		
E1HC-E3HC	Crankcase heater	R1T-R7T R31T, R32T	Thermistor	Y1E	Electronic expansion valve (main)		
F1U	Fuse (250V, 8A Ⓢ)(A4P, A8P)		R1T	Air (A1P)	Y2E	Electronic expansion valve (subcool)	
F1U, F2U	Fuse (250V, 3.15A Ⓢ)(A1P)		R1T	Fin (A3P)	Y1S-Y3S	Solenoid valve	
F5U	Field Fuse		R2T	Suction		Y1S	Hot gas
F400U	Fuse (250V, 6.3A Ⓢ)(A2P)		R31T	M1C Discharge		Y2S	Oil return
H1P-H8P	Pilotlamp (service monitor - orange) [H2P] prepare test.....Flickering Malfunction detection.....Light up		R32T	M2C Discharge		Y3S	4 way valve
			R33T	M3C Discharge	Z1C-Z9C	Noise filter (ferrite core)	
			R4T	Heat exch. deicer	Z1F	Noise filter (with surge absorber)	
HAP	Pilotlamp (service monitor - green)	R5T	Heat exch. outlet				
K1	Magnetic relay	R6T	Liquid pipe		Cool/heat selector		
K2	Magnetic contactor (M1C)	R7T	Accumulator	S1S	Selector switch (fan / cool - heat)		
K2M	Magnetic contactor (M2C, M3C)	R10	Resistor (current sensor) (A4P)	S2S	Selector switch (cool-heat)		
K1R, K2R	Magnetic relays (K2M, K3M)	R50, R59	Resistor				

BLK	Black	RED	Red	YLW	Yellow	WHT	White	PNK	Pink
BRN	Brown	GRY	Grey	GRN	Green	ORG	Orange	BLU	Blue
	Field wiring		Terminal strip		Connector		Terminal		Protective earth (screw)

NOTES

- This wiring diagram only applies to the outdoor unit.
- When using the option adapter, refer to the installation manual.
- Do not operate the unit by short-circuiting protection device S1PH.
- Refer to the installation manual for connecting wiring to BP-outdoor transmission F1-F2.
- When using the central control system, connect outdoor-outdoor transmission F1-F2.

9 External connection diagrams

9 - 1 External Connection Diagrams

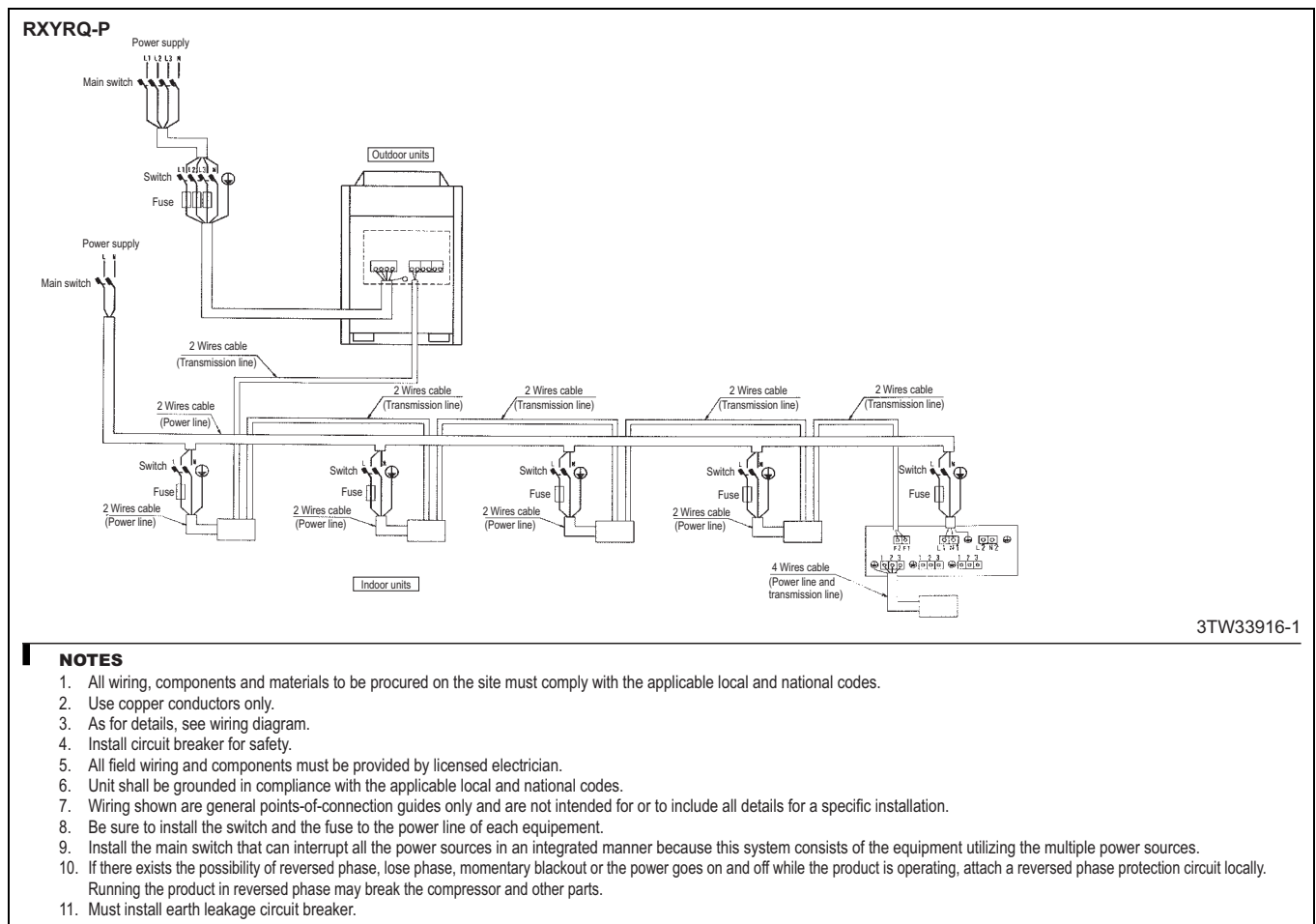

10 Sound data

10 - 1 Sound Power Spectrum

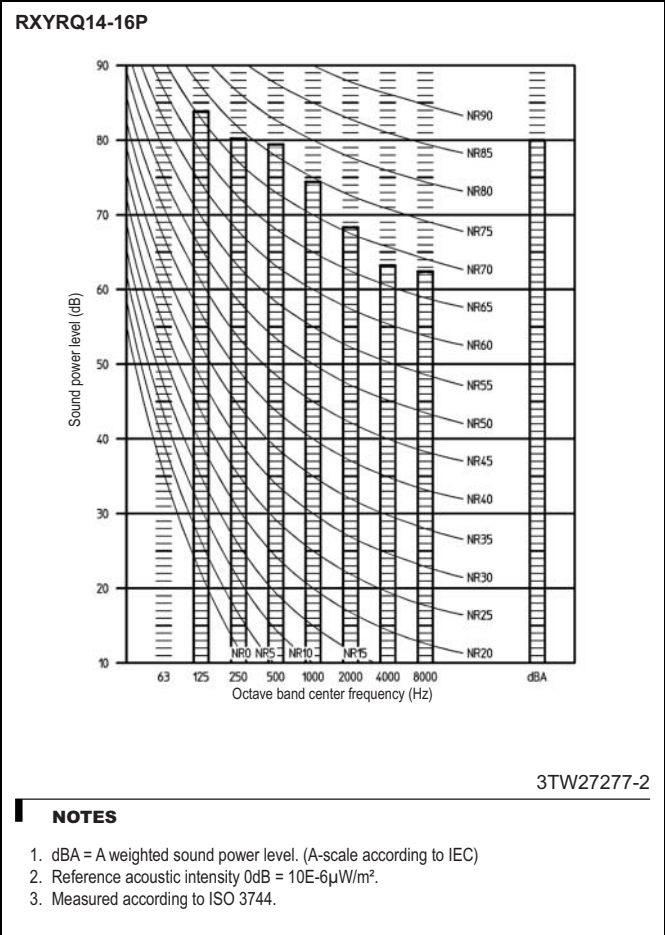
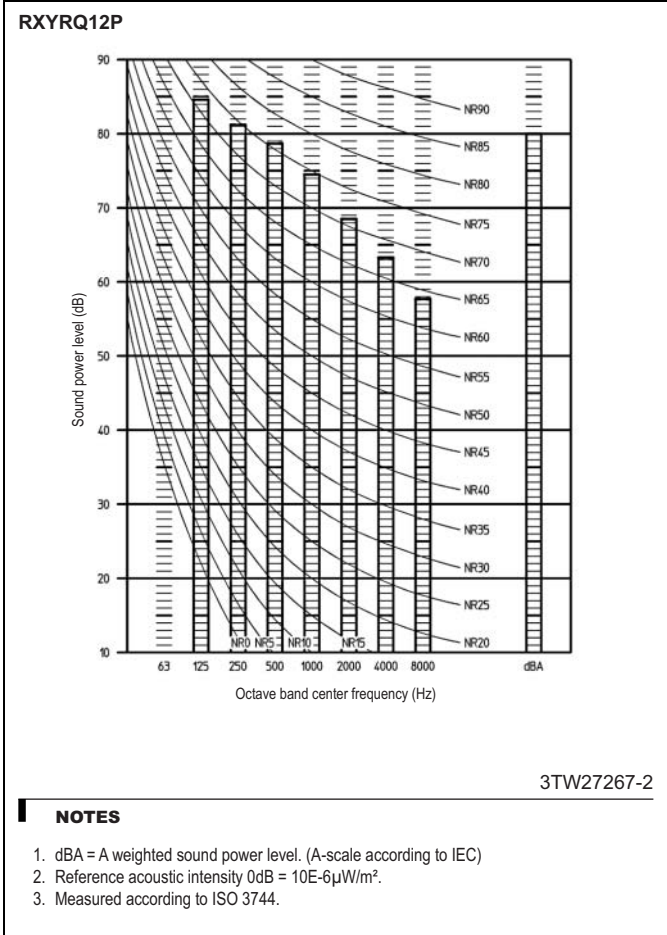
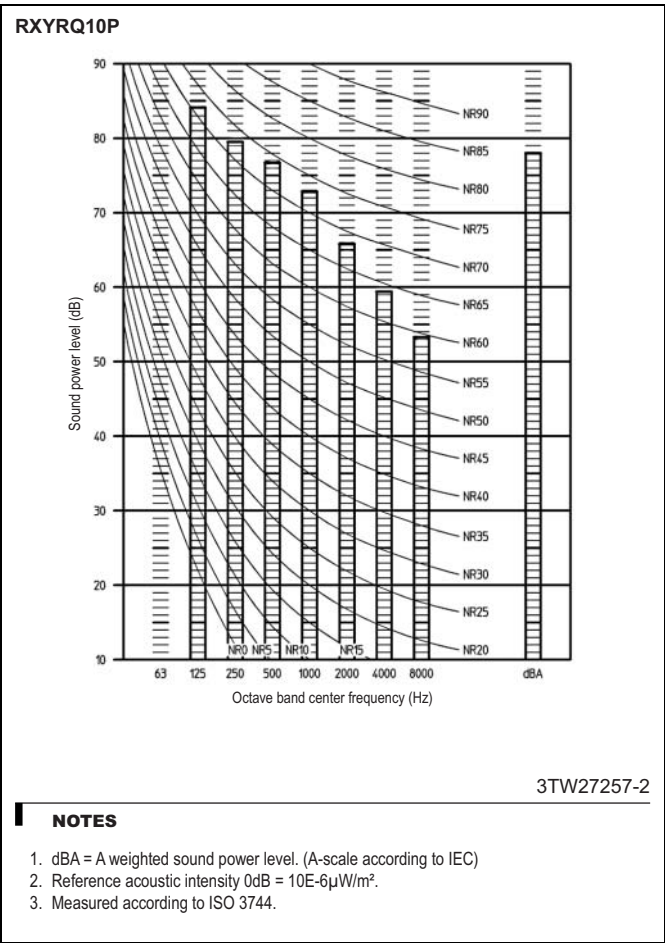
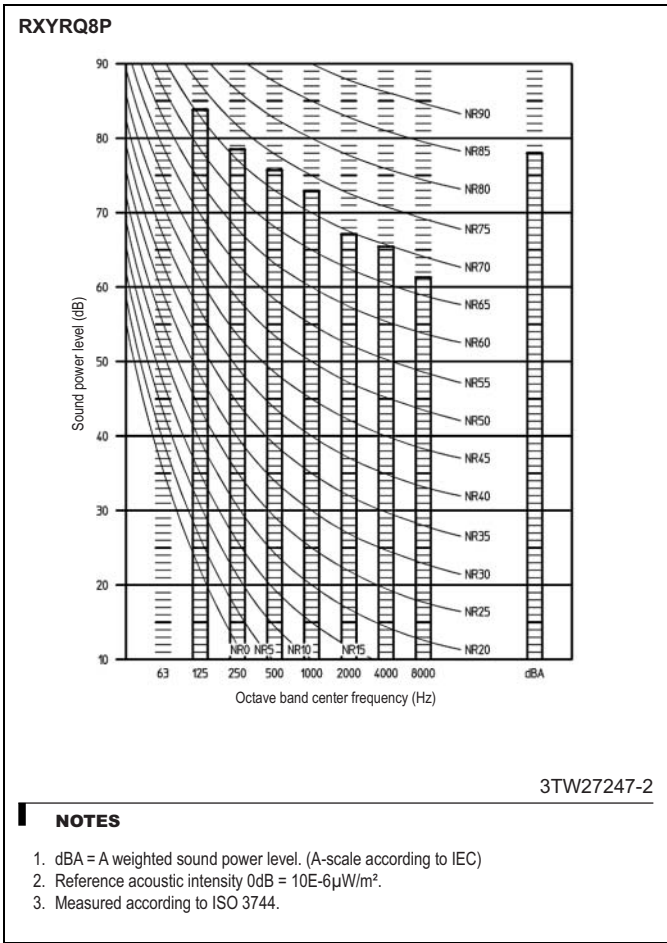

10 Sound data

10 - 1 Sound Power Spectrum

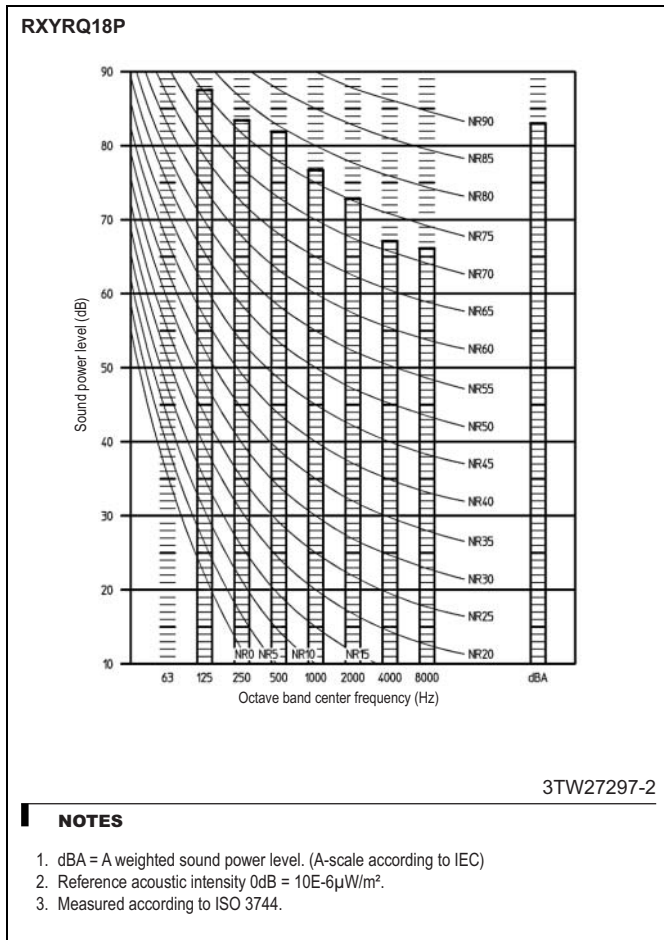

10 Sound data

10 - 2 Sound Pressure Spectrum

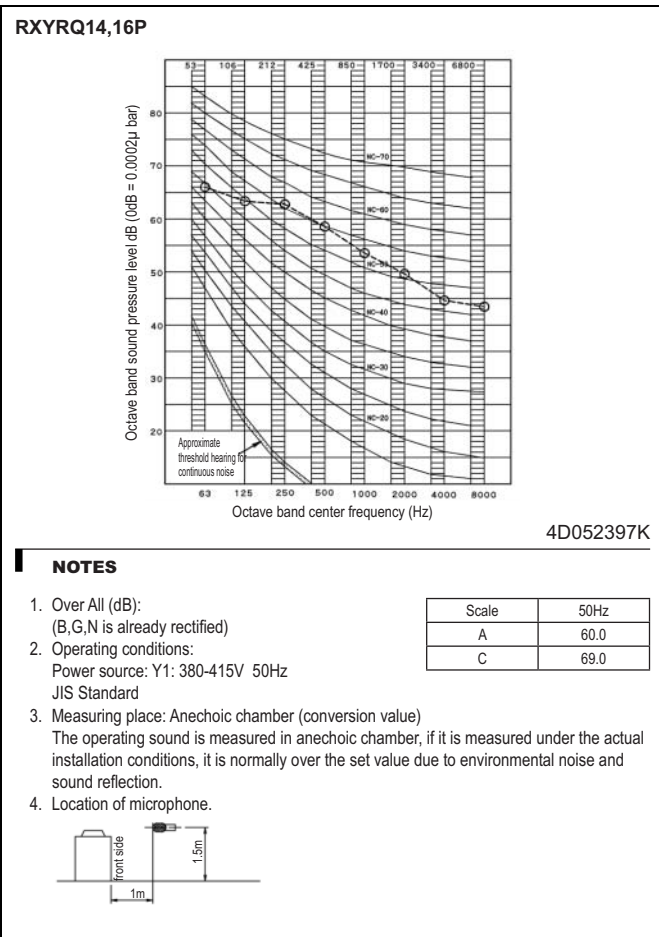
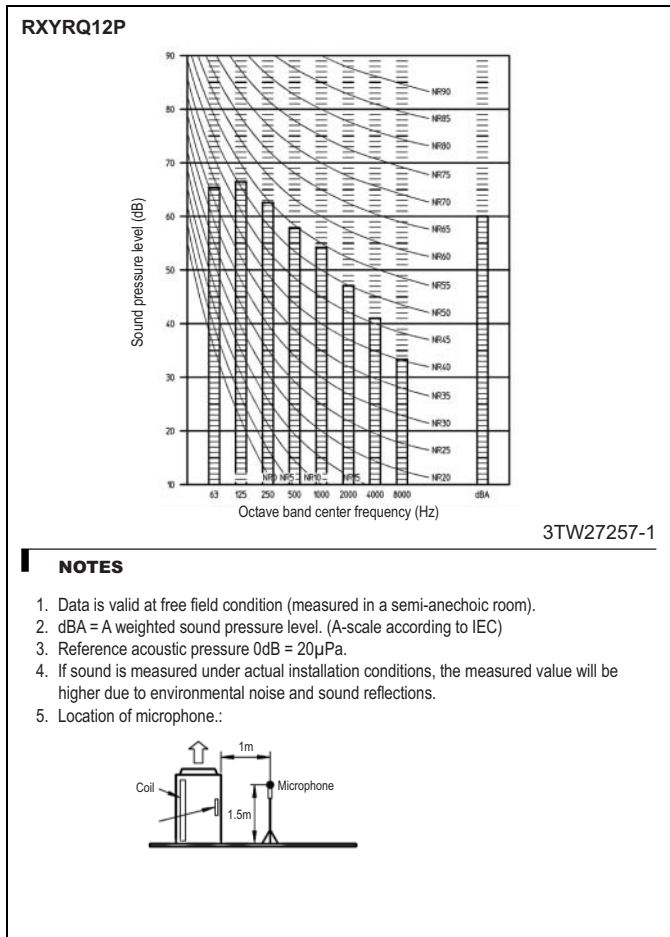
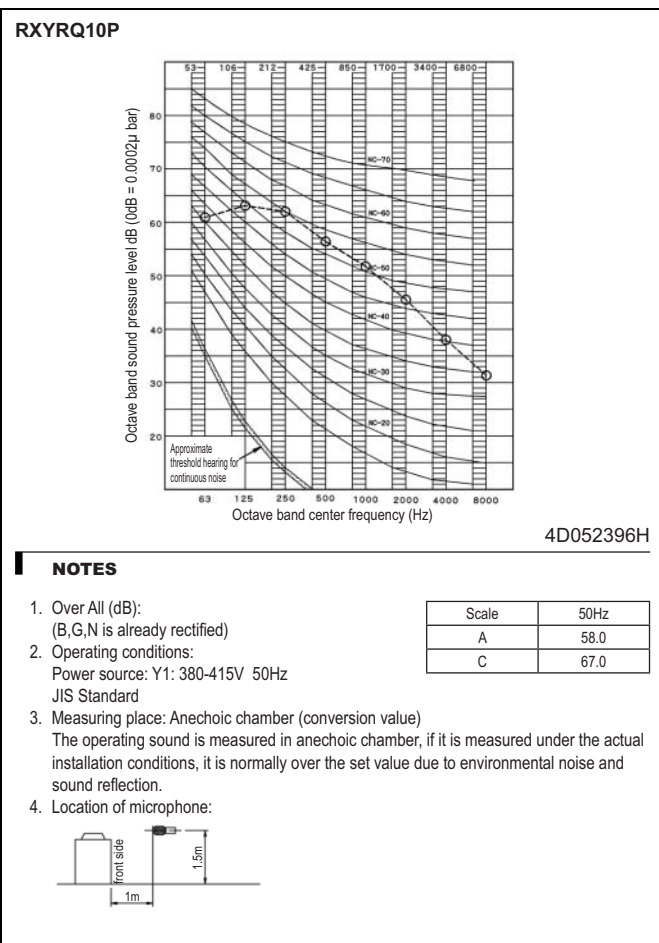
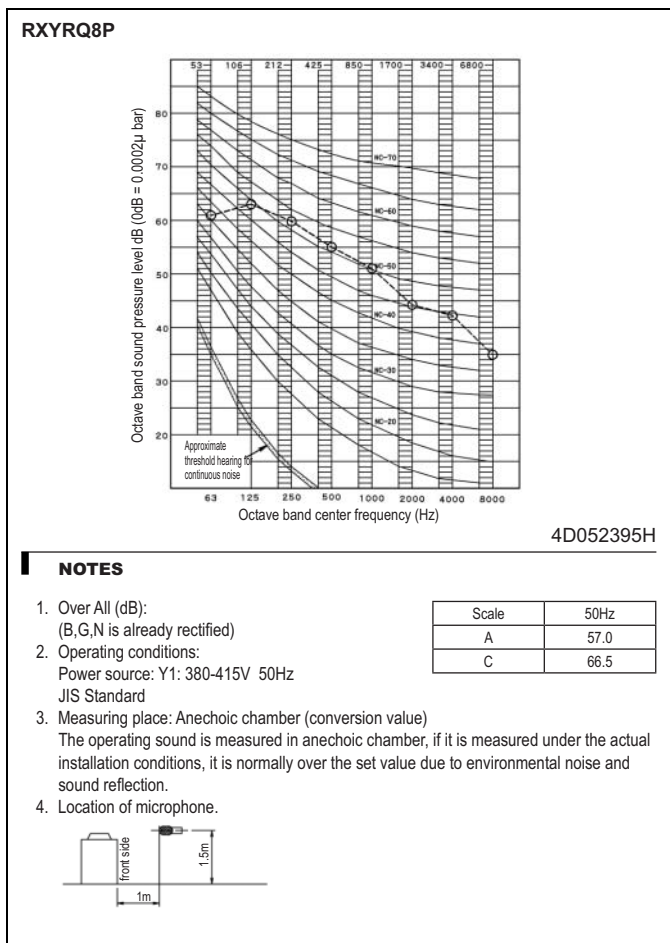

10 Sound data

10 - 2 Sound Pressure Spectrum

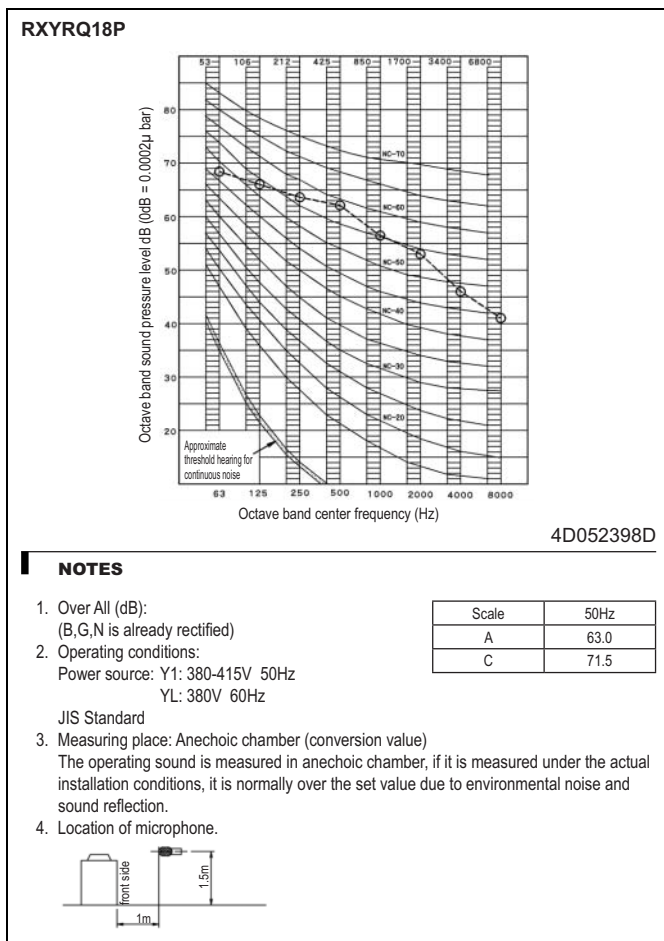

11 Installation

11 - 1 Service Space

RXYRQ-P

For single unit installation

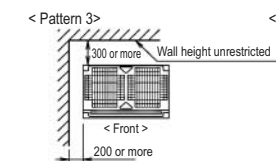
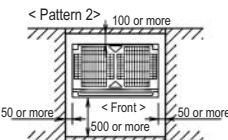
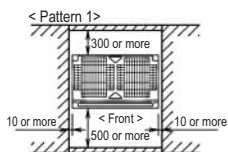

For installation in rows

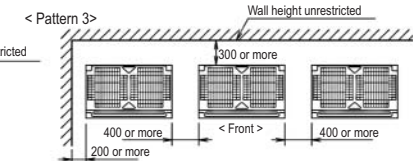
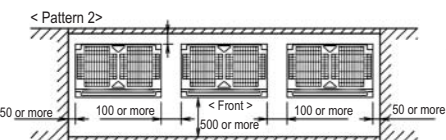
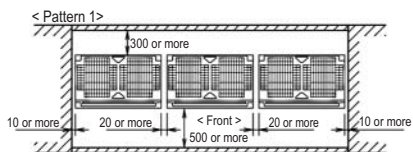

For centralized group layout

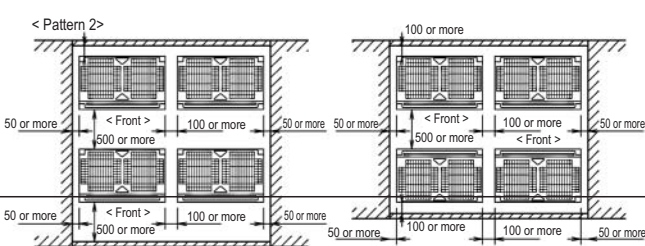
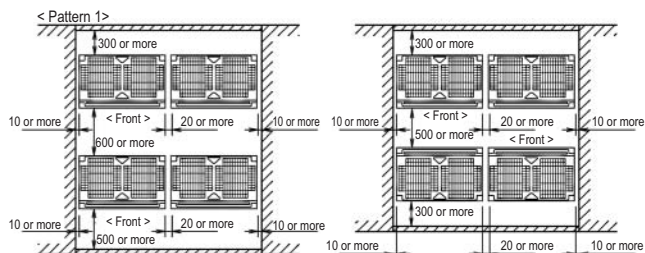

< Unit: mm >

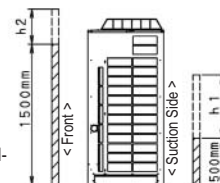

NOTES

1. Heights of walls in case of Patterns 1 and 2:

Front: 1500mm

Suction side: 500mm

Side: Height unrestricted.

Installation space to be shown in this drawing is based on the cooling operation at 35 degrees outdoor air temperature. When the design outdoor air temperature exceeds 35 degrees or the load exceeds maximum ability because of much generation load of heat in all outdoor units, take the suction side space more broadly than the space to be shown in this drawing.

2. If the above wall heights are exceeded then h2/2 and h1/2 should be added to the front and suction side service spaces respectively as shown in the figure on the right.

3. When installing the units most appropriate pattern should be selected from those shown above in order to obtain the best fit in the space available always bearing in mind the need to leave enough space for a person to pass between units and wall and for the air to circulate freely. (If more units are to be installed than are catered for in the above patterns your layout should take account of the possibility of short circuits.)

4. The units should be installed to leave sufficient space at the front for the on site refrigerant piping work to be carried out comfortably.

3D051451R

11 Installation

11 - 2 Fixation and Foundation of Units

RXYRQ-P

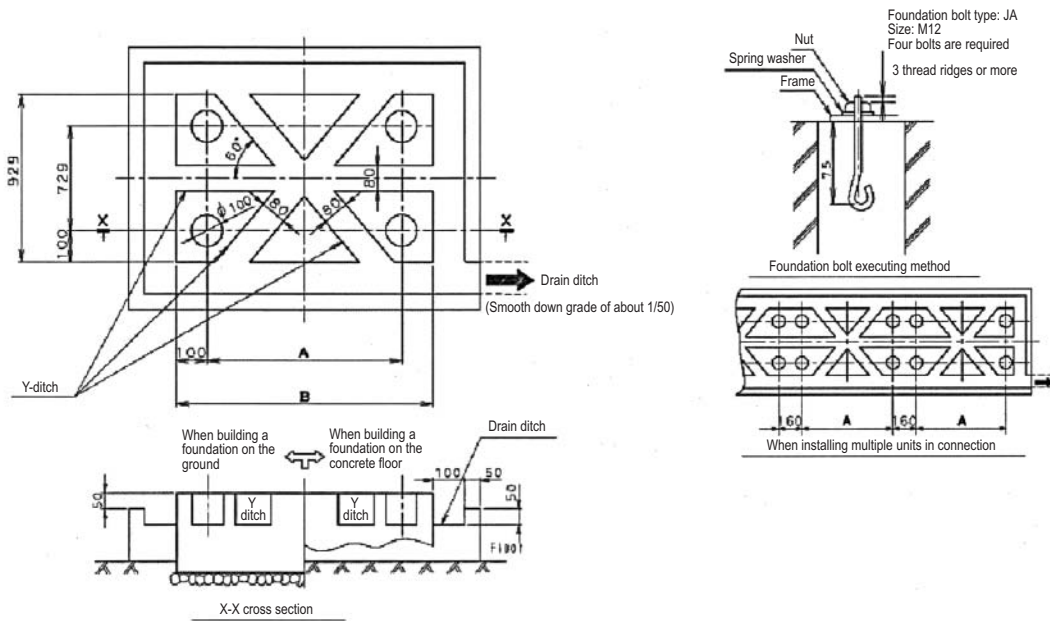

3TW33919-1

NOTES

1. The proportions of cement : sand : gravel for the concrete shall be 1 : 2 : 4; and the reinforcement bars that their diameter are from 10mm (approx. 300mm intervals) shall be placed.
2. The surface shall be finished with mortar. The corner edges shall be chamfered.
3. When the foundation is built on a concrete floor, rubble is not necessary. However, the surface of the section on which is the foundation is built shall have rough finish.
4. A drain ditch shall be made around the foundation to thoroughly drain water from the equipment installation area.
5. When installing the equipment on a roof, the floor strength shall be checked and water-proofing measures shall be taken.

11 Installation

11 - 3 Refrigerant Pipe Selection

RXYRQ-P

Example of connection (Connection of 8 units heat pump system)		Branch with refnet joint – First branch to BP unit		Branch with refnet joint – First branch to VRV unit															
<p>Example of connection (Connection of 8 units heat pump system)</p> <ul style="list-style-type: none"> Sky air or room air conditioner indoor unit VRV indoor unit refrigerant branch kit (refnet joint) BP unit <p>NOTE The refrigerant branch kits must be positioned as close to the BP units as possible (e, g must be as short as possible for the application that the first branch goes to a BP unit).</p>																			
	<p>Maximum allowable length</p> <p>Between outdoor and BP units</p> <p>Between BP and an indoor unit</p> <p>Between outdoor and indoor units</p> <p>Between outdoor unit and the first refrigerant branch kit</p> <p>Between outdoor and indoor units</p> <p>Between outdoor and BP units</p> <p>Between BP and BP units</p> <p>Between indoor and indoor units</p> <p>Allowable length after the branch</p>	<p>Maximum pipe length</p> <p>1 room length</p> <p>Total pipe length</p> <p>Pipe length</p> <p>Difference in height</p> <p>Difference in height</p> <p>Difference in height</p> <p>Difference in height</p> <p>Pipe length</p>	<p>Pipe length between outdoor and BP unit ≤100 m [Example] BP unit 2: a+b+c+d≤100 m</p> <p>Pipe length between BP and an indoor unit:</p> <table border="1"> <thead> <tr> <th>Indoor unit capacity</th> <th>Pipe length</th> </tr> </thead> <tbody> <tr> <td><60</td> <td>2~15 m</td> </tr> <tr> <td>60</td> <td>2~12 m</td> </tr> <tr> <td>71</td> <td>2~8 m</td> </tr> </tbody> </table> <p>[Example] 2 msh, i, j, k, l≤15 m</p> <p>Piping length between outdoor and indoor units: ≤250 m [Example] a+b+c+d+e+f+g+h+i+j+k+l≤250 m</p> <p>Pipe length between outdoor unit and first refrigerant branch kit: ≤5 m [Example] a=5 m</p> <p>Difference in height between outdoor and indoor units (H1)≥40 m (if outdoor unit is located below the indoor unit) and (H1)≤50 m (if indoor unit is located below the outdoor unit)</p> <p>Difference in height between outdoor and BP units (H2)≥40 m</p> <p>Difference in height between BP and BP units (H3)≥15 m</p> <p>Difference in height between indoor and indoor units (H4)≥15 m</p> <p>Pipe length from first BP branch kit (refnet joint) to furthest BP unit and furthest VRV indoor unit ≤50 m. If pipe length ≥20 m, a liquid/gas size up is required.^(b) [Example] BP unit 2: b+c+d≤50 m [Example] VRV indoor unit 7: b+c+d≤50 m</p>	Indoor unit capacity	Pipe length	<60	2~15 m	60	2~12 m	71	2~8 m	<p>Pipe length between outdoor and BP unit ≤100 m [Example] BP unit 2: a+b+c+d≤100 m</p> <p>Pipe length between BP and an indoor unit:</p> <table border="1"> <thead> <tr> <th>Indoor unit capacity</th> <th>Pipe length</th> </tr> </thead> <tbody> <tr> <td><60</td> <td>2~15 m</td> </tr> <tr> <td>60</td> <td>2~12 m</td> </tr> <tr> <td>71</td> <td>2~8 m</td> </tr> </tbody> </table> <p>[Example] 2 msh, i, j, k, l≤15 m</p> <p>Piping length between outdoor and indoor units: ≤250 m [Example] a-b-c-d+e+f+g+h+i+j+k+l≤250 m</p> <p>Pipe length between outdoor unit and first refrigerant branch kit: ≤5 m [Example] a=5 m</p> <p>Difference in height between outdoor and indoor units (H1)≥40 m (if outdoor unit is located below the indoor unit) and (H1)≤50 m (if indoor unit is located below the outdoor unit)</p> <p>Difference in height between outdoor and BP units (H2)≥40 m</p> <p>Difference in height between BP and BP units (H3)≥15 m</p> <p>Difference in height between indoor and indoor units (H4)≥15 m</p> <p>Pipe length from first BP branch kit (refnet joint) to furthest BP unit and furthest VRV indoor unit ≤50 m. If pipe length ≥20 m, a liquid/gas size up is required.^(b) [Example] BP unit 2: b+c+d≤50 m [Example] VRV indoor unit 7: b+c+d≤70 m</p>	Indoor unit capacity	Pipe length	<60	2~15 m	60	2~12 m	71
Indoor unit capacity	Pipe length																		
<60	2~15 m																		
60	2~12 m																		
71	2~8 m																		
Indoor unit capacity	Pipe length																		
<60	2~15 m																		
60	2~12 m																		
71	2~8 m																		
	<p>(a) The refrigerant sound from the outdoor unit can be transmitted.</p> <p>(b) A liquid/gas size up is required for all the piping between the branch kit and BP unit/VRV unit. If the piping diameter of the sized up piping exceeds the diameter of the branch kit, then the latter also requires a liquid/gas size up.</p>																		

11 Installation

11 - 3 Refrigerant Pipe Selection

RXYRQ-P

Example of connection (Connection of 8 units heat pump system)		Branch with refnet joint and refnet header – First branch to BP unit	Branch with refnet joint and refnet header – First branch to VRV unit
<p>1 Sky air or room air conditioner indoor unit</p> <p>VRV indoor unit</p> <p>refrigerant branch kit (refnet joint)</p> <p>refrigerant branch kit (refnet header)</p> <p>BP unit</p> <p>NOTE The refrigerant branch kits must be positioned as close to the BP units as possible (e.g. must be as short as possible for the application that the first branch goes to a BP unit).</p>			
Maximum allowable length	Between outdoor and BP units	Pipe length between outdoor and BP unit ≤100 m [Example] BP unit 2: a+b+d≤100 m	Pipe length between outdoor and BP unit ≤100 m [Example] BP unit 2: a+b+d≤100 m
	Between BP and an indoor unit	Pipe length between BP and an indoor unit: Indoor unit capacity Pipe length <60 2~15 m 60 2~12 m 71 2~8 m [Example] 2 msh, i, j, k, l ≤15 m	Pipe length between BP and an indoor unit: Indoor unit capacity Pipe length <60 2~15 m 60 2~12 m 71 2~8 m [Example] 2 msh, i, j, k, l ≤15 m
	Between outdoor and indoor units	Piping length between outdoor and indoor units: ≤250 m [Example] a+b+c+d+e+f+g+h+i+j+k+l≤250 m	Piping length between outdoor and indoor units: ≤250 m [Example] a+b+c+d+e+f+g+h+i+j+k+l≤250 m
Minimum allowable length ^(a)	Between outdoor unit and the first refrigerant branch kit	Pipe length between outdoor unit and first refrigerant branch kit: ≥5 m [Example] a≥5 m	Pipe length between outdoor unit and first refrigerant branch kit: ≥5 m [Example] a≥5 m
Allowable height	Between outdoor and indoor units	Difference in height between outdoor and indoor units (H1)≥40 m (if outdoor unit is located below the indoor unit) and (H1)≤50 m (if indoor unit is located below the outdoor unit)	Difference in height between outdoor and indoor units (H1)≥40 m (if outdoor unit is located below the indoor unit) and (H1)≤50 m (if indoor unit is located below the outdoor unit)
	Between outdoor and BP units	Difference in height between BP and BP units (H2)≥40 m	Difference in height between outdoor and BP units (H2)≥40 m
	Between BP and BP units	Difference in height between BP and BP units (H3)≤15 m	Difference in height between BP and BP units (H3)≤15 m
Allowable length after the branch	Between indoor and indoor units	Difference in height between indoor and indoor units (H4)≤15 m	Difference in height between indoor and indoor units (H4)≤15 m
	Pipe length	Pipe length from first BP branch kit (refnet joint or refnet header) to furthest BP unit and furthest VRV indoor unit ≤50 m. If pipe length >20 m, a liquid/gas size up is required. ^(b) [Example] BP unit 2: b+g≤50 m [Example] VRV indoor unit 7: b+d≤50 m	Pipe length from first BP branch kit (refnet joint or refnet header) to furthest BP unit and furthest VRV indoor unit ≤50 m. If pipe length >20 m, a liquid/gas size up is required. ^(b) [Example] BP unit 2: b+d≤70 m [Example] VRV indoor unit 7: b+c+g≤70 m

(a) The refrigerant sound from the outdoor unit can be transmitted.
(b) A liquid/gas size up is required for all the piping between the branch kit and BP unit/VRV unit. If the piping diameter of the sized up piping exceeds the diameter of the piping before the first BP branch kit or refrigerant branch kit, then the latter also requires a liquid/gas size up.

11 Installation

11 - 3 Refrigerant Pipe Selection

RXYRQ-P

Refrigerant branch kit selection		How to select the refnet joint		How to select the refnet header	
Refrigerant branch kits can only be used with R410A.		When using refnet joints at the first branch counted from the outdoor unit side. Choose from the following table in accordance with the capacity of the outdoor unit.		<ul style="list-style-type: none"> Choose from the following table in accordance with the total capacity of all the indoor units connected below the refnet header. Note: 250 type cannot be connected below the refnet header. 	
Outdoor unit capacity type		Refrigerant branch kit name		Refrigerant branch kit name	
RXYRQ8~10	KHRQ22M29T9	KHRQ22M29H (Max. 8 branch)		KHRQ22M64H (Max. 8 branch) ^(a)	
RXYRQ12~18	KHRQ22M64T				
For refnet joints other than the first branch, select the proper branch kit model based on the total capacity index.					
Indoor capacity type		Refrigerant branch kit name		Indoor capacity type	
<200	KHRQ22M20T			<290	
200≤x<290	KHRQ22M29T9			290≤x<585	
290≤x<585	KHRQ22M64T				
				(a) If the pipe size above the refnet header is Ø34.9 or more, KHRQ22M75H is required	
Choose from the following table in accordance with the outdoor unit total capacity type, connected downstream					
Pipe size selection		Symbol		Piping size (outer diameter x minimum thickness)	
Between outdoor and first refrigerant branch kit		a		Gas pipe	Liquid pipe
				Ø19.1x1.0	Ø9.5x0.8
				Ø22.2x1.0	Ø12.7x0.8
				Ø28.6x1.0	Ø15.9x0.8
Piping between refrigerant branch kits		b,c		Gas pipe	Liquid pipe
<ul style="list-style-type: none"> Choose from the following table in accordance with the total capacity of all the indoor units connected below this. Do not let the connection piping exceed the refrigerant piping size chosen by general system model name. 				Ø15.9	Ø9.5
				Ø19.1	Ø9.5
				Ø22.2	Ø12.7
				Ø28.6	Ø15.9
Between refrigerant branch kit and BP unit				Gas pipe	Liquid pipe
<ul style="list-style-type: none"> Pipe size for direct connection to BP unit must be based on the total capacity of the connected indoor units. 				Ø12.7	Ø6.4
				Ø15.9	Ø9.5
				Ø19.1	Ø9.5
Between BP unit and indoor unit			h,i,j,k,l	Gas pipe	Liquid pipe
				Ø9.5	Ø6.4
				Ø12.7	Ø9.5
				Ø15.9	Ø9.5
Piping between refrigerant branch kit and indoor unit				Gas pipe	Liquid pipe
<ul style="list-style-type: none"> Pipe size for direct connection to indoor unit must be the same as the connection size of the indoor units. 				Ø12.7	Ø6.4
				Ø15.9	Ø9.5
				Ø19.1	Ø9.5
				Ø22.2	Ø9.5

How to calculate the additional refrigerant to be charged
 Additional refrigerant to be charged R (kg)
 R should be rounded off in units of 0.1 kg

$$R = [(X1 \times \text{Ø15.9}) \times 0.18] + [(X2 \times \text{Ø12.7}) \times 0.12] + [(X3 \times \text{Ø9.5}) \times 0.059] + [(X4 \times \text{Ø6.4}) \times 0.022] + A$$

X_{1,2,3,4} = Total length (m) of liquid piping size at Ø
 A = Weight according to table

A	8-12	0 kg
	14-18	1 kg

Example for refrigerant branch using refnet joints with first branch to BP unit for RXYRQ18P
 If the outdoor unit is RXYRQ18P and the piping lengths are as below.

a: Ø15.9x7 m	e: Ø9.5x4 m	i: Ø9.5x4 m
b: Ø12.7x5 m	f: Ø9.5x6 m	j: Ø9.5x4 m
c: Ø12.7x10 m	g: Ø12.7x6 m	k: Ø6.4x8 m
d: Ø6.4x10 m	h: Ø9.5x3 m	l: Ø6.4x6 m

R = [7x0.18]+[2x0.12]+[2x0.059]+[2x0.022]+1 = 6.547 kg ⇒ R = 6.5 kg

12 Operation range

12 - 1 Operation Range

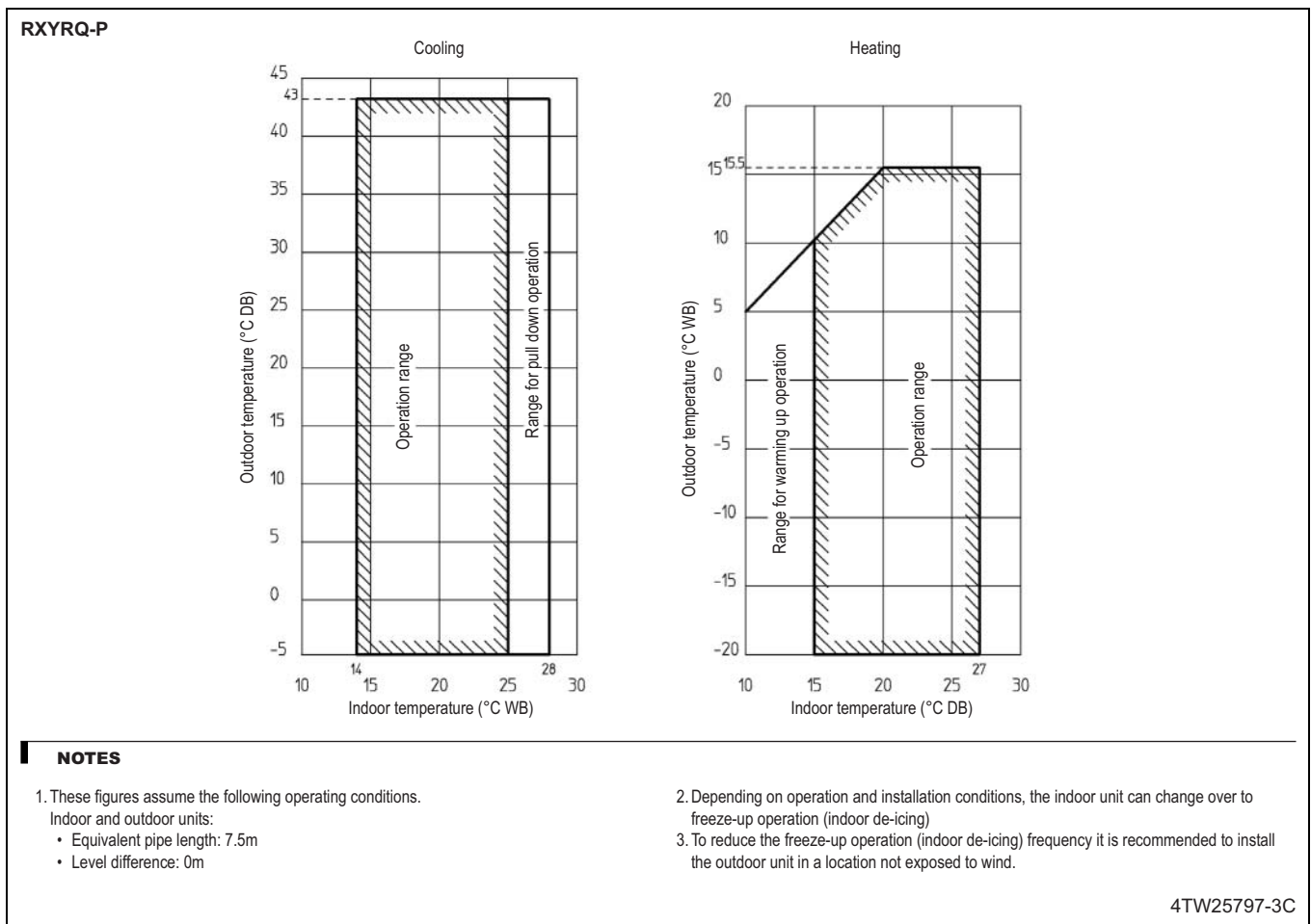

In all of us,
a green heart



Daikin's unique position as a manufacturer of air conditioning equipment, compressors and refrigerants has led to its close involvement in environmental issues. For several years Daikin has had the intention to become a leader in the provision of products that have limited impact on the environment. This challenge demands the eco design and development of a wide range of products and an energy management system, resulting in energy conservation and a reduction of waste.



VRV® products are not within the scope of the Eurovent certification programme.

The present publication is drawn up by way of information only and does not constitute an offer binding upon Daikin Europe N.V. Daikin Europe N.V. has compiled the content of this publication to the best of its knowledge. No express or implied warranty is given for the completeness, accuracy, reliability or fitness for particular purpose of its content and the products and services presented therein. Specifications are subject to change without prior notice. Daikin Europe N.V. explicitly rejects any liability for any direct or indirect damage, in the broadest sense, arising from or related to the use and/or interpretation of this publication. All content is copyrighted by Daikin Europe N.V..

Daikin products are distributed by: