



Air Conditioners

Technical Data

Economiser option for UATYQ



EEDEN11-107

ECONO-AY1

Air Conditioners

Technical Data

Economiser option for UATYQ



EEDEN11-107

TABLE OF CONTENTS

ECONO-AY1

1	Features	2
2	Specifications	3
	Technical Specifications	3
3	Control systems	4
	Control Systems	4
4	Dimensional drawings	6
	Dimensional Drawings	6
5	Installation	7
	Installation Method	7

1 Features

- Higher efficiency thanks to free cooling application
- Fresh air intake ensures higher comfort levels
- Easy to install: no additional wiring is needed as the rooftop units have the economiser PCB as standard
- High flexibility: choice between side or bottom air discharge

2 Specifications

2-1 Technical Specifications				ECONO250AMY1	ECONO350AMY1	ECONO450AMY1	ECONO550AMY1	ECONO600AMY1	ECONO700AMY1	
Dimensions	Unit	Height	mm	-						
		Width	mm	-						
		Depth	mm	-						
	Packed unit	Height	mm	534						
		Width	mm	1,440	1,430		1,458			
		Depth	mm	1,144	1,124		1,564			
Weight	Unit		kg	51	42	43	53	54	69	
Packing	Weight		kg	152	140	141	165	166	181	
Fan	Air flow rate	Cooling	Nom.	l/s	1,560	2,030	2,670	3,160	3,445	3,917
				cfm	3,300	4,300	5,650	6,700	7,300	8,300
Option for				UATYQ250CY1	UATYQ350CY1	UATYQ450CY1	UATYQ550CY1	UATYQ600CY1	UATYQ700CY1	

3 Control systems

3 - 1 Control Systems

(v) Economiser control

- Ensure the economiser kit has been incorporated with rooftop unit before activate the economiser function in the controller main board. Else, error will occur.
- To activate economiser function, set Dip Switch Setting: SW4 - ON (default is OFF) in the controller main board and panel parameter G6 to '1' (default is '0')

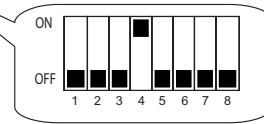

NOTES

G6 = Economiser control

0 = disable

1 = enable.

- In economiser controller board, there are 4 dip switches and 3 shunt jumpers which provide flexible selection based on different requirements:
 - Dip Switch 1: Minimum fresh air opening setting in heating mode, where by the selection of different pins will give different opening setting. SW1: 5%, SW2: 10%, SW3: 15%, SW4: 20%, SW5: 25%, SW6/7/8: no function, Default: 0% (no selection, all OFF).
 - Dip Switch 2: Minimum fresh air opening setting in cooling mode, where by the selection of different pins will give different opening setting. SW1: 0%, SW2: 5%, SW3: 15%, SW4: 20%, SW5: 25%, SW6/7/8: no function, Default: 10% (no selection, all OFF).
 - Dip Switch 3: CO₂ PPM level threshold value selection, where by the selection of different pins will give different value setting. SW1: 25%, SW2: 50%, SW3: 75%, SW4: 100%, Default: 0% (no selection, all OFF).
 - Dip Switch 4: Type of operation, which include the following selection:-
 - SW1: OFF = Differential temperature operation (default), ON = No function at this moment.
 - SW2: OFF = Economiser mode (default), ON = Fresh air mode.
 - SW3: OFF = Overcooled protection is not activated (default), ON = Overcooled protection is activated.

3 Control systems

3 - 1 Control Systems

Shunt jumper 1, 2 and 3: Minimum fresh air opening setting in fan mode, where by the selection of different pins will give different opening setting. Let name the shunt jumper 1 = JP1, shunt jumper 2 = JP2 and shunt jumper 3 = JP3; refer the table below for different fresh air opening selection:

Fresh air opening (%)	JP1	JP2	JP3
0 (default)	OFF	OFF	OFF
10	OFF	OFF	ON
20	OFF	ON	OFF
30	OFF	ON	ON
40	ON	OFF	OFF
50	ON	OFF	ON
70	ON	ON	OFF
85	ON	ON	ON

Legend: OFF = Short pin 2 and pin 3
ON = Short pin 1 and pin 2

CAUTION

Dip Switch 1, 2 and 3 allow only 1 pin selection. Multiple pins selection will cause error and the operation will go back to default setting. While Dip Switch 4 allow multiple pins selection.

Location of dip switches and shunt jumpers in the economiser controller board:

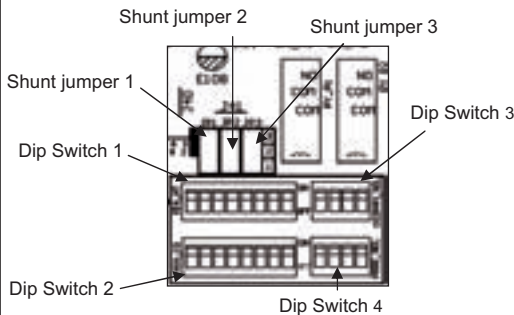

Indication on the economiser controller board:

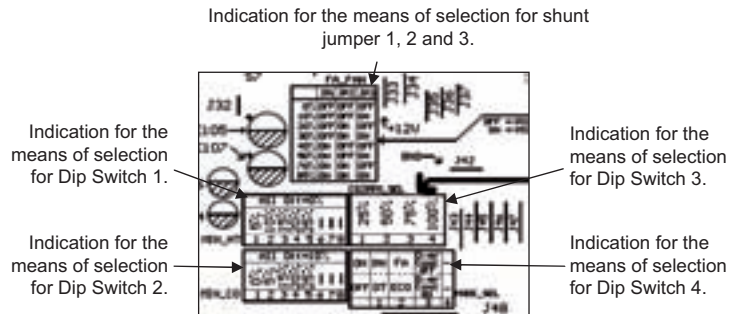

- There are two LEDs in economiser controller board, which are green LED and red LED. Green LED will blink when economiser controller board is powered-up. Red LED will blink when error(s) occur. Refer the table below for error codes and their meaning:

Error Code	Fault
F0	Fresh air actuator faulty/ malfunction
F1	Return air actuator faulty/ malfunction
F2	Communication error
F3	CO ₂ sensor short
F4	CO ₂ sensor open
F5	Fresh air RH sensor short
F6	Fresh air RH sensor open
F7	Return air RH sensor short
F8	Return air RH sensor open
F9	Activation of actuator protection
FA	Multiple pins selection in Dip Switch 1, 2 or 3

NOTES

The error codes will be shown on the seven segment display on the economiser controller board.

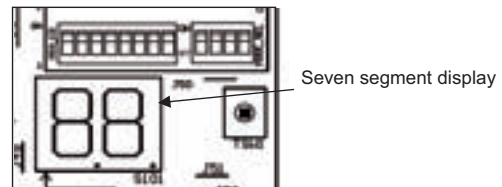

NOTES

When error(s) occur and the faults persist, please call your authorized local dealer/ serviceman for troubleshooting. However, all the errors occur in economiser controller board will not affect the normal operation of rooftop unit.

4 Dimensional drawings

4 - 1 Dimensional Drawings

Explode View - Economiser Kit_EN

B Preinstallation Checking

(i) The Contents of Economiser Kit

Before installation, it is recommended to check the contents of the economiser kit after removing the packaging. The kit includes the following components:

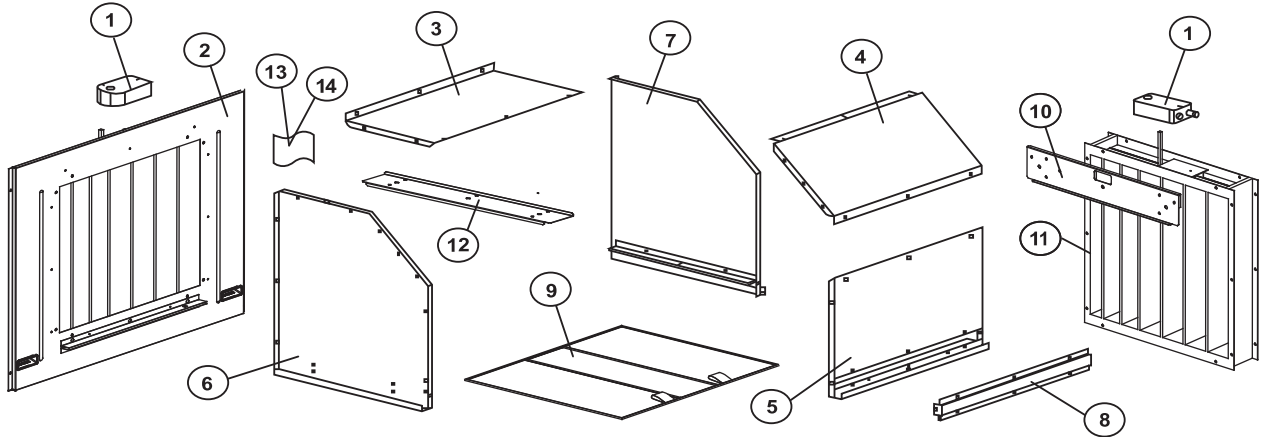

No.	Item Description	Quantity (set)
1	Belimo actuator, LF24-SR	2
2	Side panel with outdoor air damper	1
3	Hood, top panel	1
4	Hood, center panel	1
5	Hood, bottom panel	1
6	Hood, side panel left	1
7	Hood, side panel right	1

No.	Item Description	Quantity (set)
8	Filter cover	1
9	Filter	1
10	Support bracket, return air damper	1
11	Return air damper	1
12	Support bracket, down throw	1
13	Screw, M5x16	55
14	Screw, M4x12	4

NOTES

Contact authorized service division if accessory is damaged or incomplete.

5 Installation

5 - 1 Installation Method

OPTIONAL ACCESSORY

ECONOMISER KIT

A Introduction

Economiser kit is an accessory provided by the factory, but requires field installation. Economiser kit is compatible for R410A rooftop models. If you are unsure whether this kit can be used with your particular unit, please contact authorized service division. The economiser kit allows outside air to be mixed with return air for 'free' cooling if the outdoor air temperature is suitable. Economiser cooling can be used alone or in conjunction with mechanical cooling. Beside that, the economiser kit can be used as well to provide ventilation air thus can improve indoor air quality. It is vital to do a correct selection on economiser kit, refer the table below for kit selection guideline:

No.	Rooftop Unit	Economiser kit which is compatible with rooftop unit
1	UATYQ250	ECONO250
2	UATYQ350	ECONO350
3	UATYQ450	ECONO450
4	UATYQ550	ECONO550
5	UATYQ600	ECONO600
6	UATYQ700	ECONO700

NOTES

Wrong selection may cause the kit is unable to be assembled with the rooftop unit.

B Preinstallation Checking

(i) The Contents of Economiser Kit

Before installation, it is recommended to check the contents of the economiser kit after removing the packaging. The kit includes the following components:

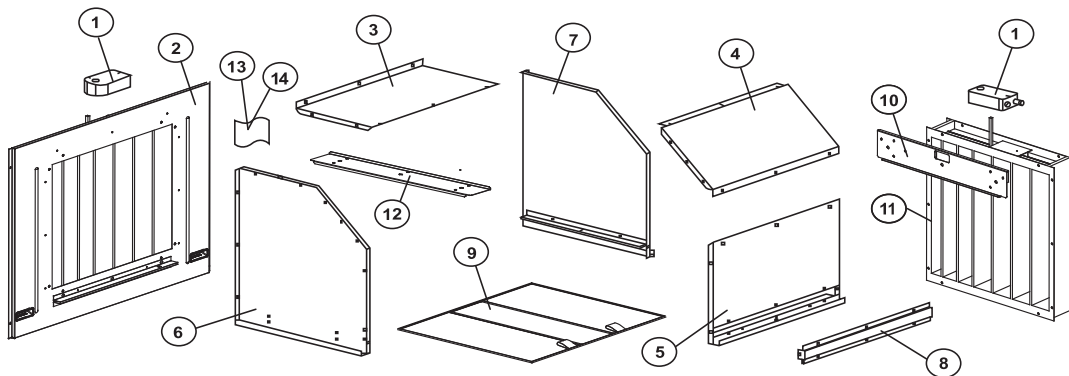

No.	Item Description	Quantity (set)
1	Belimo actuator, LF24-SR	2
2	Side panel with outdoor air damper	1
3	Hood, top panel	1
4	Hood, center panel	1
5	Hood, bottom panel	1
6	Hood, side panel left	1
7	Hood, side panel right	1

No.	Item Description	Quantity (set)
8	Filter cover	1
9	Filter	1
10	Support bracket, return air damper	1
11	Return air damper	1
12	Support bracket, down throw	1
13	Screw, M5x16	55
14	Screw, M4x12	4

NOTES

Contact authorized service division if accessory is damaged or incomplete.

(ii) Unit Clearance

Provide sufficient space for air flow, servicing and wiring after the kit is mounted on the unit. There shall be no obstruction of air flow in this space. Refer to part (F) under chapter "INSTALLATION OF THE UNIT" in this manual. Fail to do so may cause low air flow or unit malfunction.

5 Installation

5 - 1 Installation Method

(iii) Location for installation

Follow the recommendations given in part (A) under chapter "INSTALLATION OF THE UNIT" in this manual. In addition, there is a need to consider the installation condition around the kit whereby:

- The clearance of the rain hood from the floor shall always have no snow nor water accumulation.
- The fresh air inlet does not face prevailing wind direction.
- The outdoor air shall be always clean and no odor, complies with the limit of concentration for several contaminants set by local standards, and does not exceed the threshold limit value (TLV) for toxicity specified by local standards.

(iv) Damper Function

Check the two dampers in the economiser kit, which are item 2 and item 11 by turning the shaft of damper +90° and -90° (fully opened to fully closed or vice versa). The damper turning shall be smooth and easy. Any damages or abnormalities shall inform to authorized service division.

C Tools And Materials Required For Installation

- | | |
|--|---|
| (i) Electric screwdriver with assorted sockets | (vii) Adjustable spanner (small size) |
| (ii) Electric driller with assorted sockets | (viii) Crowbar and hammer |
| (iii) Small flat blade screwdriver | (ix) Weather-proof sealant (such as silicone) |
| (iv) Cutter | (x) Gasket |
| (v) Philip type screwdriver | (xi) Safety lockout tag |
| (vi) Measurement tape or ruler | (xii) Cable tie |

D Installation Guidelines

(i) Side return (horizontal) application

STEP 1

- Disconnect power supply to the unit and install a safety lockout tag before installation, commissioning or service of the economiser unit. Prepare all the tools required as mentioned above.

STEP 2

- Unpack the wooden crate of economiser kit by using crowbar and hammer. Then, remove the polybags containing loose parts and fasteners by using cutter. Perform preinstallation checking as mentioned above.

STEP 3

- Attach support bracket, return air damper (item 10) to return air damper (item 11) by using screw M5x16 (item 13) provided in the kit.

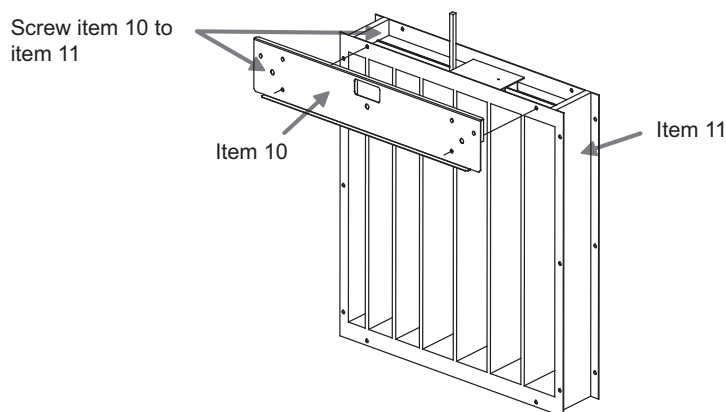

STEP 4

- Mount 1pc Belimo actuator, LF24-SR (item 1) labelled with 'RA' to return air damper (item 11). Align and insert the hole of actuator to the shaft of the damper.



CAUTION 1

The default setting for return air damper (item 11) shall be fully opened. Ensure this damper is in 'fully opened' position before mounting it to the actuator. Failed to do so will cause errors during the unit operation.



CAUTION 2

The surface of actuator which is facing upward/ outside shall be labelled with 'L' symbol to ensure the rotation of actuator modulation in clockwise direction. Failed to do so will cause errors during the operation of unit with economiser function.

5 Installation

5 - 1 Installation Method

NOTES

There are 2pcs of Belimo actuator, LF24-SR (item 1) in economiser kit which come together with carton boxes. Open the boxes and recognize the label on the wire. The actuator used in step 4 is the one with label 'RA'.

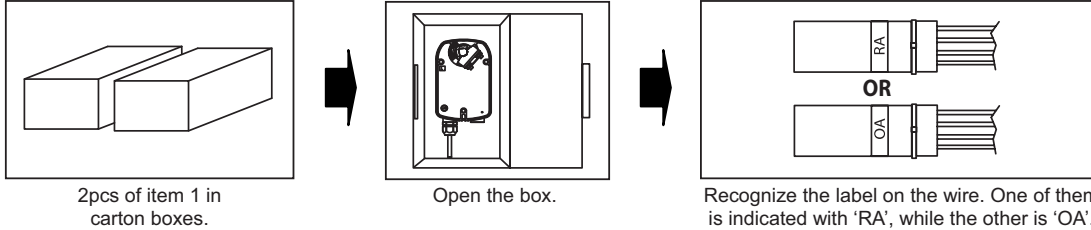

- Then, fastens 1pc screw M4x12 (item 14) on the support bracket of the damper. Do not fully insert the screw thread, but only insert up to 2/3 of the screw thread. Mount the actuator to the support bracket by bringing the support bracket closer to the shaft of damper. The function of screw M4x12 is to lock the actuator from slipperry during modulation.
- Next, put the clamp into the shaft and lock the actuator with circlip. Fasten the nuts of clamp tightly by using adjustable spanner. Noted that clamp and circlip come together with actuator as the standard parts, you may find these parts inside the actuator box.

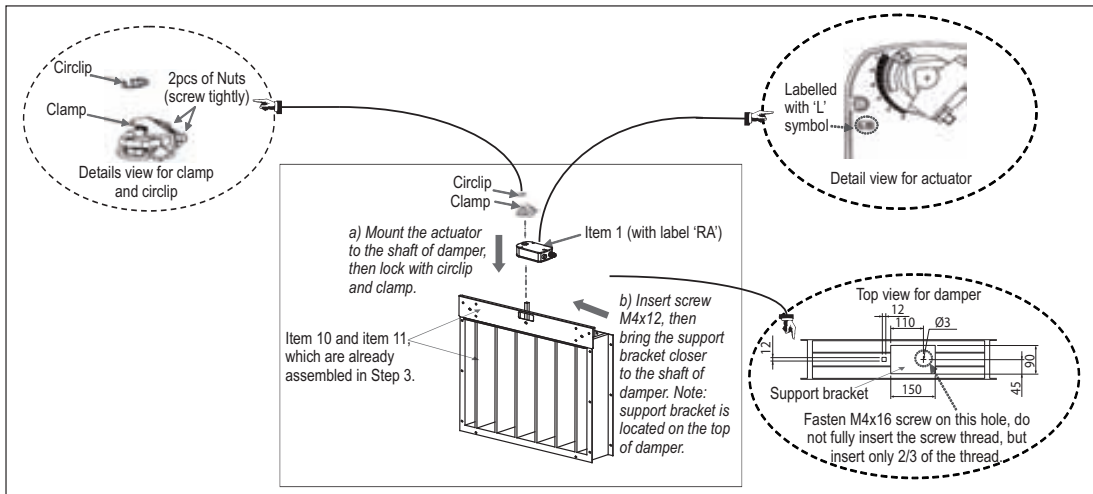

STEP 5

- Remove side panel. Then, detach 4pcs metal bracket on front panel. Install the return air damper (item 11) + support bracket, return air damper (item 10) + Belimo actuator, LF24-SR (item 1) which are already assembled in step 3 and step 4 into front panel of the unit by using the same screw holes. Use screw M5x16 (item 13) for fastening purpose.



CAUTION

Extend the return air sensor which is located inside the unit (on top of return air opening) to the outside area of the unit. This can be done by routing the sensor through small holes on support bracket, return air damper (item 10). The sensor is then located properly inside the return air duct by using the cable ties (field supply). Failing to do so may affect the performance of the unit and cause thermal discomfort to the users.

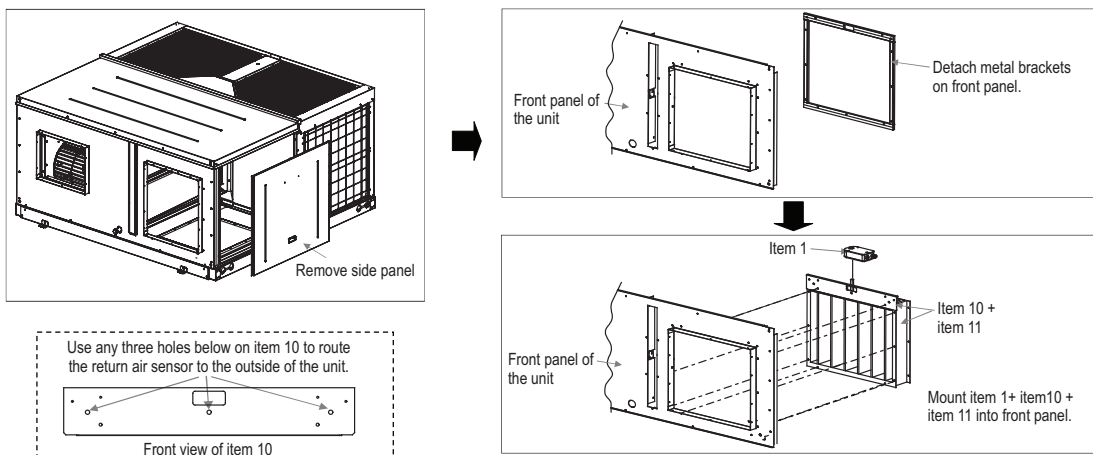

5 Installation

5 - 1 Installation Method

STEP 6

- Mount 1pc Belimo actuator, LF24-SR (item 1) labelled with 'OA' to the side panel with outdoor air damper (item 2). Align and insert the hole of actuator to the shaft of the damper.



CAUTION 1

The default setting for outdoor air damper (item 2) shall be fully closed. Ensure this damper is in 'fully closed' position before mount the actuator. Fail to do so will cause errors during the unit normal operation.



CAUTION 2

The surface of actuator which is facing upward/ outside shall be labelled with 'R' symbol to ensure the rotation of actuator modulation in counter clockwise direction. Fail to do so will cause errors during the operation of unit with economiser function.

NOTES

There are 2pcs of Belimo actuator, LF24-SR (item 1) in economiser kit which come together with carton boxes. Open the boxes and recognize the label on the wire. The actuator used in step 6 is the one with label 'OA'.

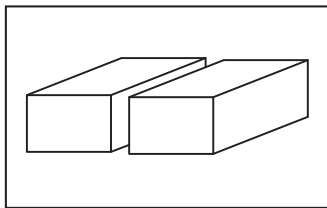

2pcs of item 1 in carton boxes.

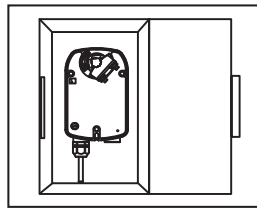

Open the box.

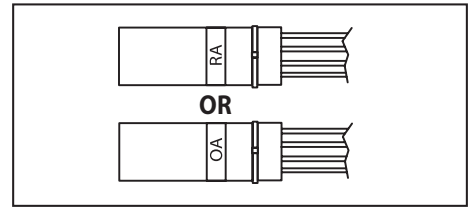

Recognize the label on the wire. One of them is indicated with 'RA', while the other is 'OA'.

- Then, fastens 1pc screw M4x12 (item 14) on the support bracket of the damper. Do not fully insert the screw thread, but only insert up to 2/3 of the screw thread. Mount the actuator to the support bracket by bringing the support bracket closer to the shaft of damper. The function of screw M4x12 is to lock the actuator from slippery during modulation.
- Next, put the clamp into the shaft and lock the actuator with circlip. Fasten the nuts of clamp tightly by using adjustable spanner. Noted that clamp and circlip come together with actuator as the standard parts, you may find these parts inside the actuator box.

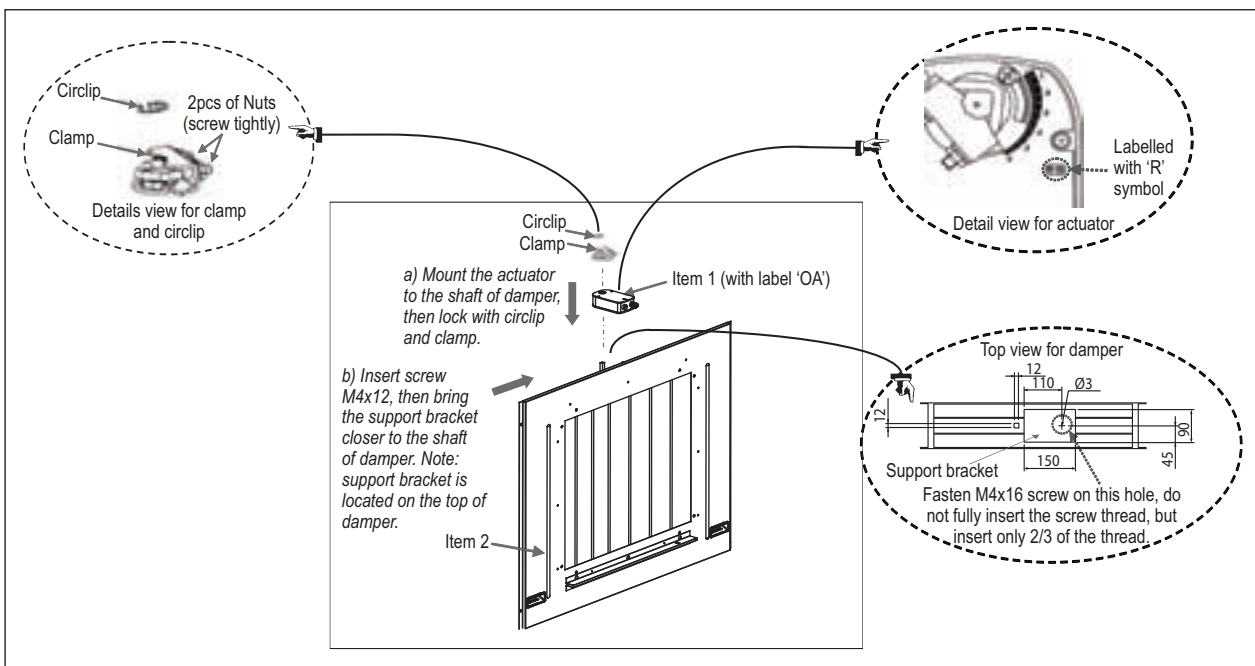

5 Installation

5 - 1 Installation Method

STEP 7

- Connect Belimo actuator, LF24-SR (item 1) with label 'RA', which is now located at the assembly damper on the front panel to terminal block with label 'RA' inside the junction box.
- There are four wires on the actuator with different colours (black, red, green and white colours). Connect the wires as below:
 Black colour wire - connect to first pole of terminal block with label 'GND'.
 Red colour wire - connect to second pole of terminal block with label '+24V'.
 Green colour wire - connect to third pole of terminal block with label 'DCV'.
 White colour wire - connect to fourth pole of terminal block with label 'FB'.
 (You may refer to sticker wiring diagram which is located on the front cover of junction box.)

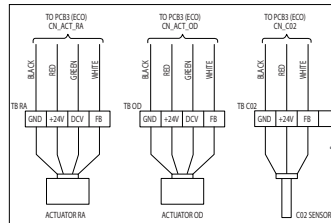

Sticker wiring diagram on the front cover of junction box



CAUTION

Wrong wiring connection may cause the malfunction on actuator or economiser controller board or both. Tie the wires with releasable cable ties under the junction box.

- Then, connect Belimo actuator, LF24-SR (item 1) with label 'OA', which is now located at the assembly damper on the side panel to terminal block with label 'OA' inside the same junction box. Follow the same method used for wiring connection between actuator 'RA' and terminal block 'RA'. Next, attach the side panel to the unit. You may need to do proper arrangement on the actuator wires by using cable ties (field supply) before attach the side panel to the unit.

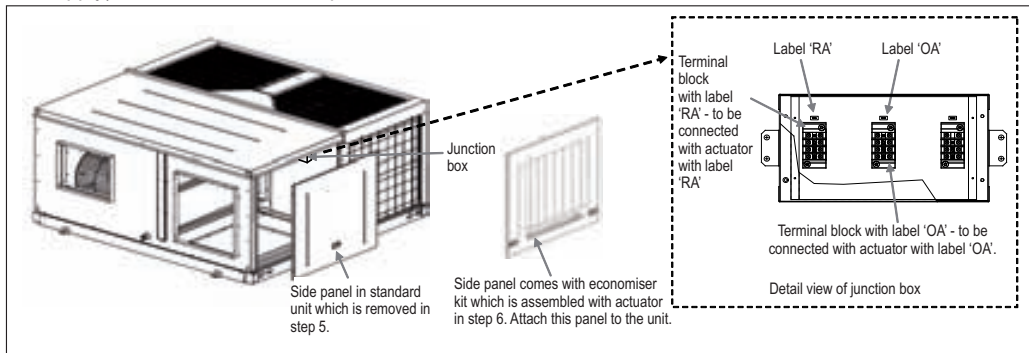

STEP 8

- To build the rain hood, install the loose parts (metal parts) to the side panel. Before that, place the gasket (field supply) on the side panel for sealing purpose.
- Then, follow the installation sequence below to build the rain hood:

Gasket
 Item 2 -----> Item 6 -----> Item 7 -----> Item 3 -----> Item 4 -----> Item 5 -----> Item 9 -----> Item 8 -----> Sealant

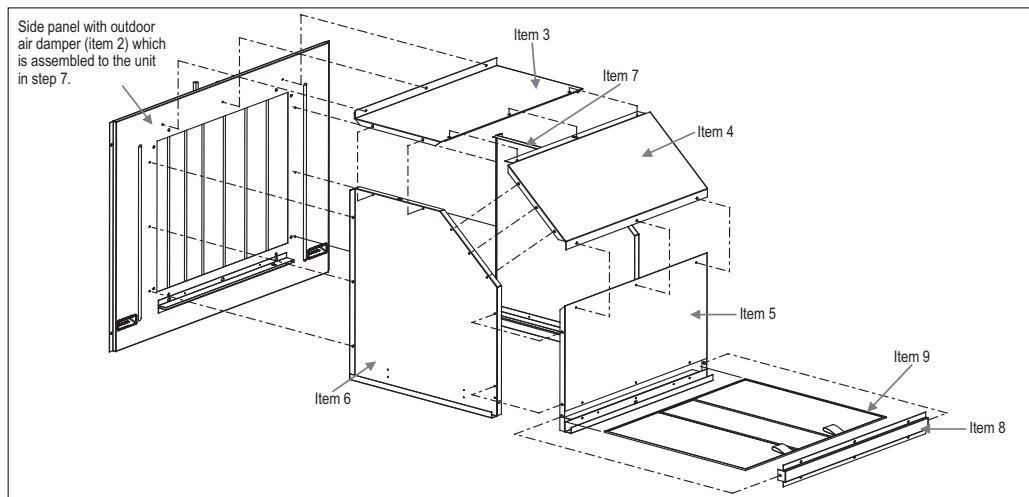

- It is recommended to seal off all the joints and gaps with weather-proof sealant (such as silicone, field supplied item) in order to ensure a water-proof finishing on the rain hood.

5 Installation

5 - 1 Installation Method

STEP 9

- Finally, you may see the unit with economiser kit as shown in the diagram below:

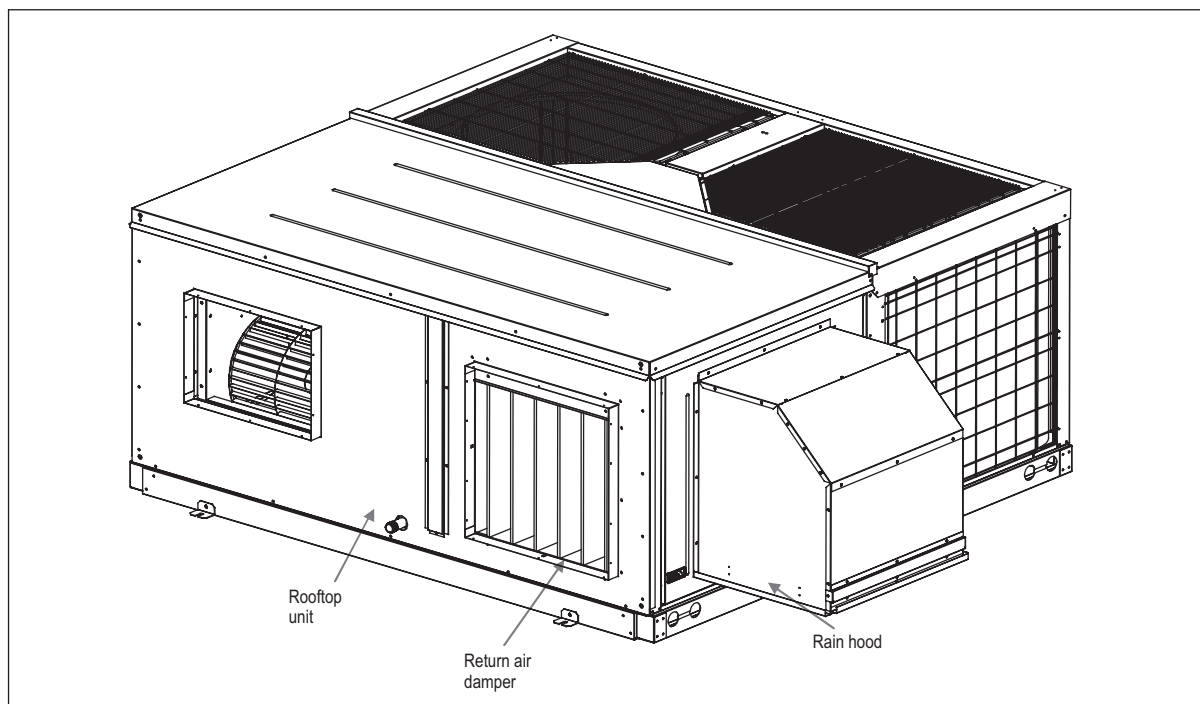

NOTES

Unit shown in the diagrams from step 1 to step 9 are UATYQ350. Other models shall follow the same method.

(ii) Down return (vertical) application

STEP 1

- Disconnect power supply to the unit and install a safety lockout tag before installation, commissioning or service of the economiser unit. Prepare all the tools required as mentioned above.

STEP 2

- Unpack the wooden crate of economiser kit by using crowbar and hammer. Then, remove the polybags containing loose parts and fasteners by using cutter. Perform preinstallation checking as mentioned above.

STEP 3

- Attach support bracket, down throw (item 12) to return air damper (item 11) by using screw M5x16 (item 13) provided in the kit.

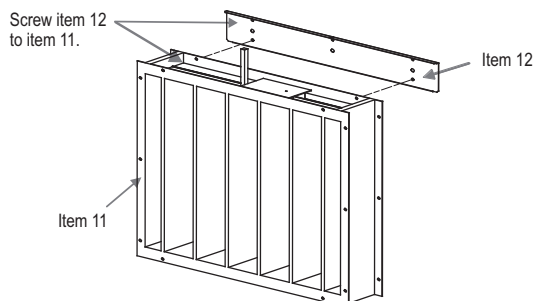

STEP 4

- Mount 1pc Belimo actuator, LF24-SR (item 1) to return air damper (item 11). Align and insert the hole of actuator to the shaft of the damper.



CAUTION 1

The default setting for return air damper (item 11) shall be fully opened. Ensure this damper is in 'fully opened' position before mount the actuator. Fail to do so will cause errors during the unit normal operation.

5 Installation

5 - 1 Installation Method



CAUTION 2

The surface of actuator which is facing upward/ outside shall be labelled with 'L' symbol to ensure the rotation of actuator modulation in clockwise direction. Fail to do so will cause errors during the operation of unit with economiser function.

NOTES

There are 2pcs of Belimo actuator, LF24-SR (item 1) in economiser kit which come together with carton boxes. Open the boxes and recognize the label on the wire. The actuator used in step 4 is the one with label 'RA'.

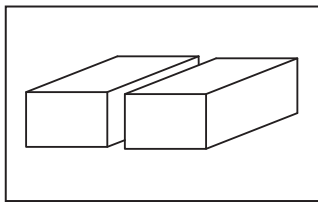

2pcs of item 1 in carton boxes.

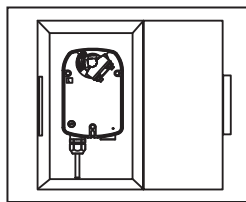

Open the box.

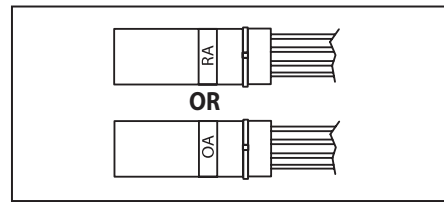

Recognize the label on the wire. One of them is indicated with 'RA', while the other is 'OA'.

- Then, fastens 1pc screw M4x12 (item 14) on the support bracket of the damper. Do not fully insert the screw thread, but only insert up to 2/3 of the screw thread. Mount the actuator to the support bracket by bringing the support bracket closer to the shaft of damper. The function of screw M4x12 is to lock the actuator from slipping during modulation.
- Next, put the clamp into the shaft and lock the actuator with circlip. Fasten the nuts of clamp tightly by using adjustable spanner. Noted that clamp and circlip come together with actuator as the standard parts, you may find these parts inside the actuator box.

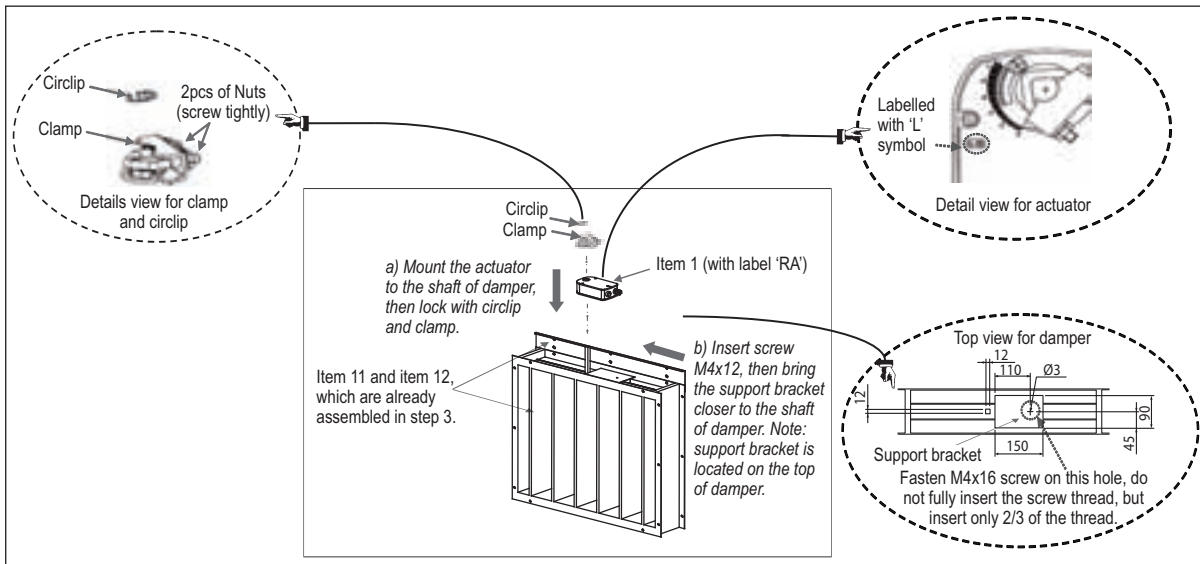

STEP 5

- Remove side panel. Conduct unit conversion from standard unit to downthrow unit by following the steps stated in part (G) under chapter "INSTALLATION OF THE UNIT" in this manual.
- Then, install the return air damper (item 11) + support bracket, down throw (item 12) + Belimo actuator, LF24-SR (item 1) which are already assembled in step 3 and step 4 into indoor base panel of the unit by using screw M5x16 (item 13).



CAUTION

Extend the return air sensor which is located inside the unit (on top of return air opening) to the outside area of the unit. This can be done by routing the sensor through small holes on support bracket, down throw (item 12). The sensor is then located properly inside the return air duct by using the cable ties (field supply). Failing to do so may affect the performance of the unit and cause thermal discomfort to the users.

5 Installation

5 - 1 Installation Method

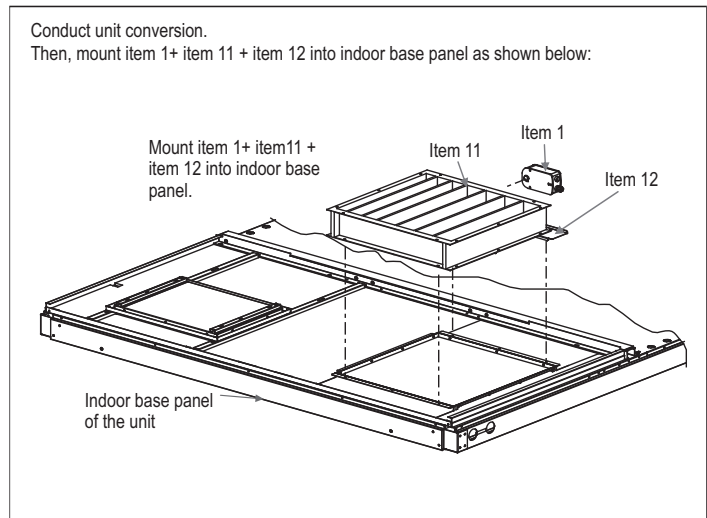
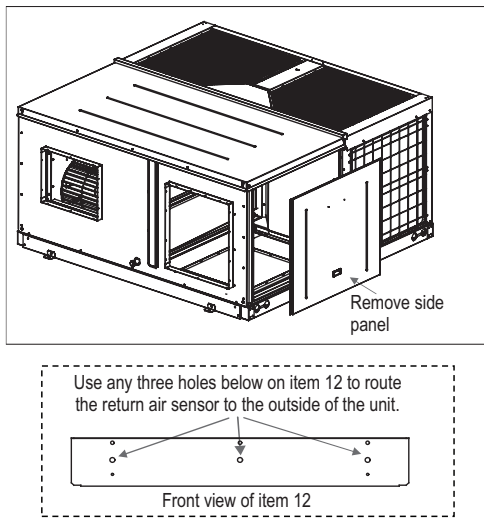

STEP 6

- Mount 1pc Belimo actuator, LF24-SR (item 1) to the side panel with outdoor air damper (item 2). Align and insert the hole of actuator to the shaft of the damper.



CAUTION 1

The default setting for outdoor air damper (item 2) shall be fully closed. Ensure this damper is in 'fully closed' position before mount the actuator. Fail to do so will cause errors during the unit normal operation.



CAUTION 2

The surface of actuator which is facing upward/ outside shall be labelled with 'R' symbol to ensure the rotation of actuator modulation in counter clockwise direction. Fail to do so will cause errors during the operation of unit with economiser function.

NOTES

There are 2pcs of Belimo actuator, LF24-SR (item 1) in economiser kit which come together with carton boxes. Open the boxes and recognize the label on the wire. The actuator used in step 6 is the one with label 'OA'.

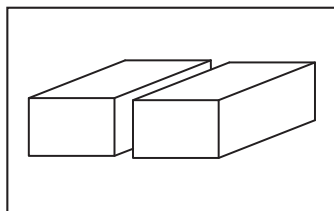

2pcs of item 1 in carton boxes.

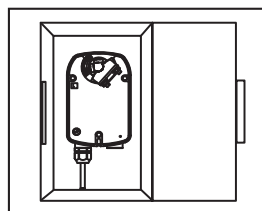

Open the box.

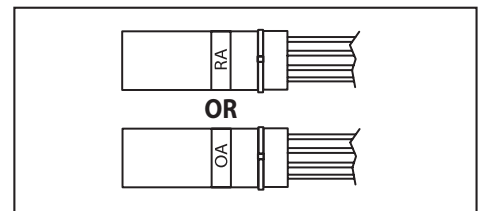

Recognize the label on the wire. One of them is indicated with 'RA', while the other is 'OA'.

- Then, fastens 1pc screw M4x12 (item 14) on the support bracket of the damper. Do not fully insert the screw thread, but only insert up to 2/3 of the screw thread. Mount the actuator to the support bracket by bringing the support bracket closer to the shaft of damper. The function of screw M4x12 is to lock the actuator from slippery during modulation.
- Next, put the clamp into the shaft and lock the actuator with circlip. Fasten the nuts of clamp tightly by using adjustable spanner. Noted that clamp and circlip come together with actuator as the standard parts, you may find these parts inside the actuator box.

5 Installation

5 - 1 Installation Method

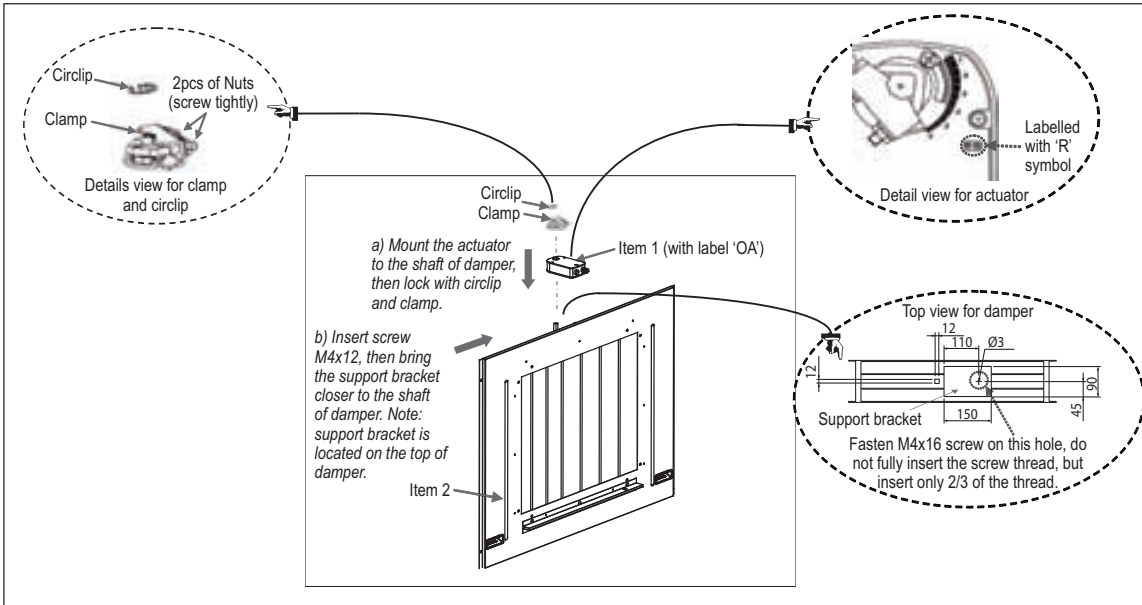

STEP 7

- Connect Belimo actuator, LF24-SR (item 1) with label 'RA', which is now located at the assembly damper on the indoor base panel to terminal block with label 'RA' inside the junction box.
- There are four wires on the actuator with different colours (black, red, green and white colours). Connect the wires as below:

- Black colour wire - connect to first pole of terminal block with label 'GND'.
- Red colour wire - connect to second pole of terminal block with label '+24V'.
- Green colour wire - connect to third pole of terminal block with label 'DCV'.
- White colour wire - connect to fourth pole of terminal block with label 'FB'.

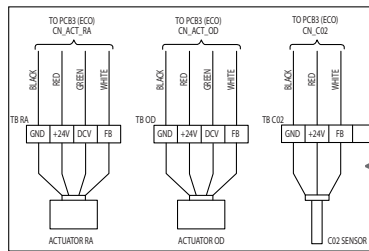

Sticker wiring diagram on the front cover of junction box

(You may refer to sticker wiring diagram which is located on the front cover of junction box.)



CAUTION

Wrong wiring connection may cause the malfunction on actuator or economiser controller board or both. Tie the wires with releasable cable ties under the junction box.

- Then, connect Belimo actuator, LF24-SR (item 1) with label 'OA', which is now located at the assembly damper on the side panel to terminal block with label 'OA' inside the same junction box. Follow the same method used for wiring connection between actuator 'RA' and terminal block 'RA'. Next, attach the side panel to the unit. You may need to do proper arrangement on the actuator wires by using cable ties (field supply) before attach the side panel to the unit.

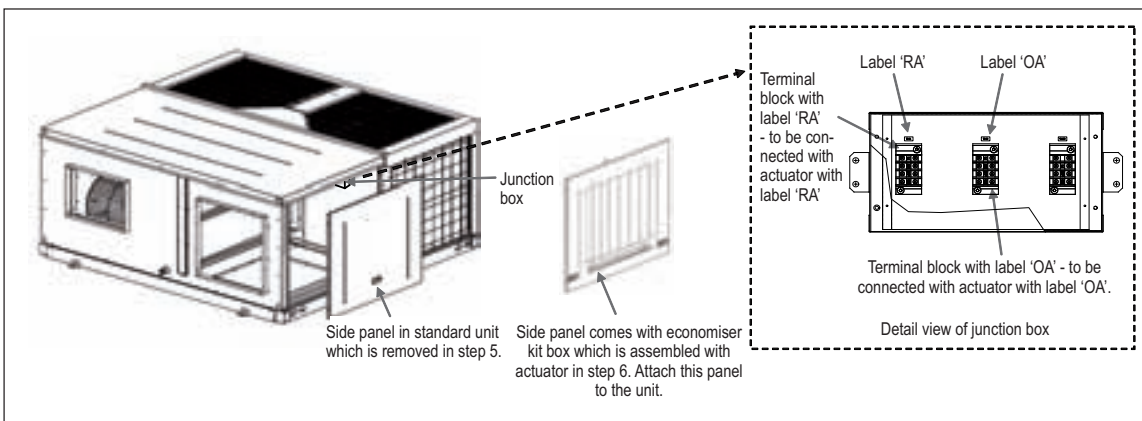

5 Installation

5 - 1 Installation Method

STEP 8

- To build the rain hood, install the loose parts (metal parts) to the side panel. Before that, place the gasket (field supply) on the side panel for sealing purpose.
- Then, follow the installation sequence below to build the rain hood:

Gasket
 Item 2 -----> Item 6 -----> Item 7 -----> Item 3 -----> Item 4 -----> Item 5 -----> Item 9 -----> Item 8 -----> Sealant

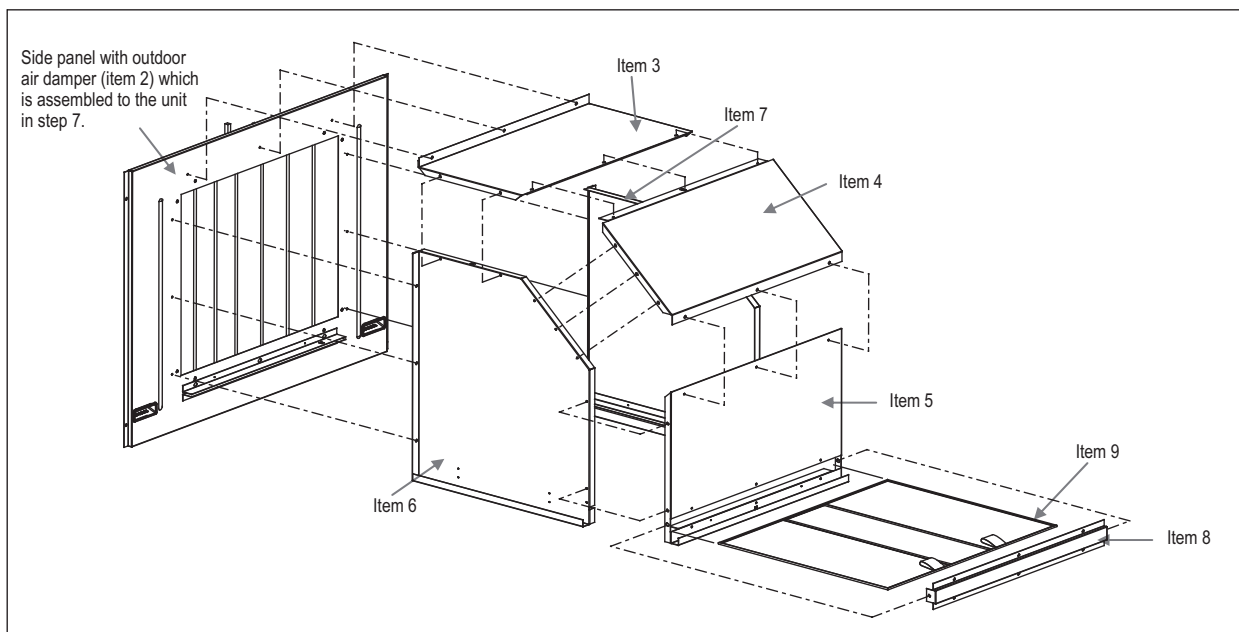

- It is recommended to seal off all the joints and gaps with weather-proof sealant (such as silicone, field supplied item) in order to ensure a water-proof finishing on the rain hood.

STEP 9

- Finally, you may see the unit with economiser kit as shown in the diagram below:
- When roof curb is required for down throw application, refer to the recommendation in part (C) under chapter "INSTALLATION OF THE UNIT" in this manual.

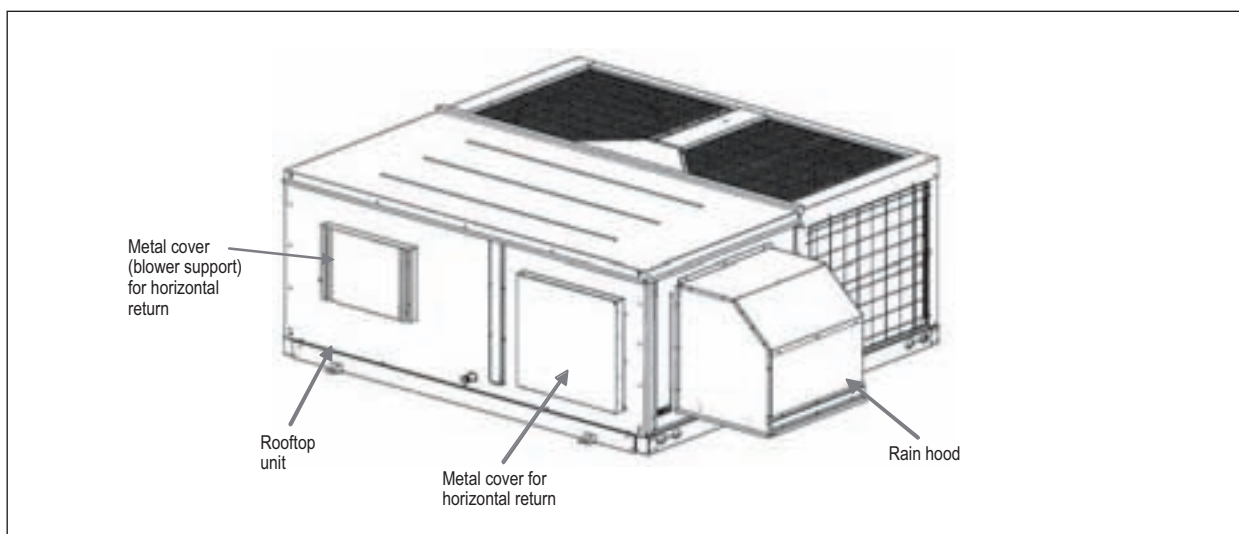

NOTES

Unit shown in the diagrams from step 1 to step 9 are UATYQ350. Other models shall follow the same method.



Daikin's unique position as a manufacturer of air conditioning equipment, compressors and refrigerants has led to its close involvement in environmental issues. For several years Daikin has had the intention to become a leader in the provision of products that have limited impact on the environment. This challenge demands the eco design and development of a wide range of products and an energy management system, resulting in energy conservation and a reduction of waste.



The present publication is drawn up by way of information only and does not constitute an offer binding upon Daikin Europe N.V. Daikin Europe N.V. has compiled the content of this publication to the best of its knowledge. No express or implied warranty is given for the completeness, accuracy, reliability or fitness for particular purpose of its content and the products and services presented therein. Specifications are subject to change without prior notice. Daikin Europe N.V. explicitly rejects any liability for any direct or indirect damage, in the broadest sense, arising from or related to the use and/or interpretation of this publication. All content is copyrighted by Daikin Europe N.V.

Daikin products are distributed by:



Daikin Europe N.V. is participating in the EUROVENT Certification Programme. Products are as listed in the EUROVENT Directory of Certified Products. Multi units are Eurovent certified for combinations up to 2 indoor units