

technical data



Rooftops

UATYP180-C12AMY1

R-407C



technical data

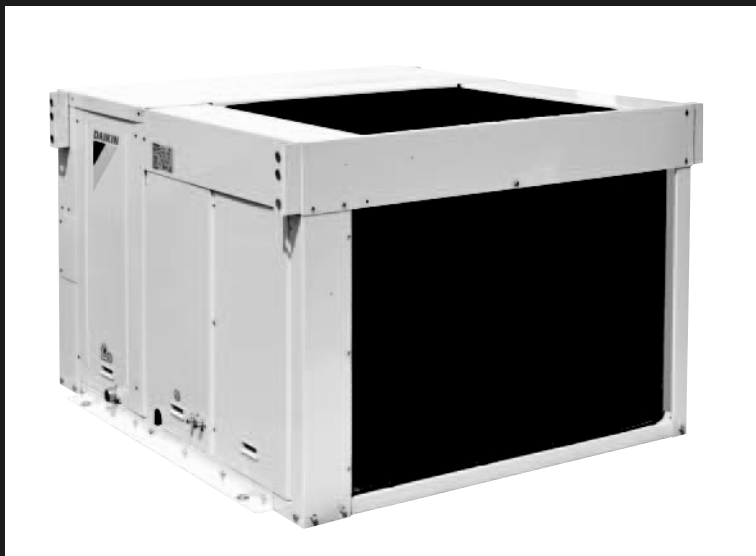

Rooftops

UATYP180-C12AMY1

R-407C

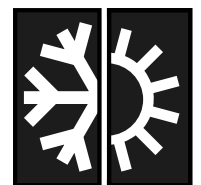

Heat pump



TABLE OF CONTENTS

UATYP-AMY1

1	Features	2
2	Specifications	3
	Capacity and Power Input	3
	Technical Specifications	3
	Electrical Specifications	4
3	Nomenclature	6
4	Features	7
5	Safety device settings	8
6	Control systems	9
7	Capacity tables	12
	Cooling capacity tables	12
	Heating capacity tables	21
8	Dimensional drawing & centre of gravity	26
	Dimensional drawing	26
9	Piping diagram	30
10	Wiring diagram	33
	Wiring diagram	33
11	Sound data	39
	Sound pressure spectrum	39
12	Fan characteristics	41
13	Operation range	45

1 Features

- Easy to install 'plug and play' concept plus single installation configuration. No additional piping is required since indoor and outdoor sides are pre-connected.
- Factory pre-charged refrigerant ensures clean and efficient operation.
- Belt driven fan enables air volume and static pressure to be adjusted as required.
- Flat top unit design allows maximum utilization of warehouse and container space.
- High efficiency and reliable scroll compressor.
- Anti-corrosion treated coil.
- Fan can be mounted for horizontal or vertical airflow inlet and discharge (UATYP240-560AMY1 only).



SLM or sequential controller

2 Specifications

2-1 Capacity and Power Input				UATYP180AMY1	UATYP240AMY1	UATYP280AMY1	UATYP320AMY1	UATYP450AMY1
Cooling	Minimum	kW		16.705	21.101	25.790	29.307	43.668
Heating	Nominal	kW		20.222	22.566	29.89	35.755	46.891
Power Input	Cooling	Nominal	kW	6.86	8.41	10.82	12.84	16.57
	Heating	Nominal	kW	6.60	7.54	9.81	11.49	15.71
EER	Nominal			2.44	2.51	2.38	2.28	2.64
COP	Nominal			3.06	2.99	3.05	3.11	2.98

2-1 Capacity and Power Input				UATYP560AMY1	UATYP700AMY1	UATYP850AMY1	UATYP10AMY1	UATYP12AMY1
Cooling	Minimum	kW		55.684	67.406	82.939	101.110	109.609
Heating	Nominal	kW		67.406	74.733	92.317	102.290	126.314
Power Input	Cooling	Nominal	kW	21.16	29.20	38.16	43.17	48.20
	Heating	Nominal	kW	20.30	26.22	34.78	41.67	46.80
EER	Nominal			2.63	2.31	2.17	2.34	2.27
COP	Nominal			3.32	2.85	2.65	2.45	2.70

2-2 Technical Specifications				UATYP180AMY1	UATYP240AMY1	UATYP280AMY1	UATYP320AMY1	UATYP450AMY1
Evaporator	Control	Air Discharge		Ducted				
		Operation		SLM Controller	SLM Controller	SLM Controller	SLM Controller	Sequential Controller
	Air Flow Rate	Cooling	m ³ /min	51	80	100	102	160
	External Static Pressure		Pa	98	98	98	98	196
Piping connections	Condensation Drain Size	Diameter (OD)	mm	25.4	25.4	25.4	25.4	25.4
Condensor	Casing	Colour		Light Grey				
		Material		Electro galvanised mild steel				
Dimensions	Unit	Height	mm	1,000	1,000	1,000	1,000	1,200
		Width	mm	1,100	1,300	1,300	1,300	1,990
		Depth	mm	1,530	1,530	1,530	1,530	1,800
	Packing	Height	mm	1,090	1,090	1,090	1,090	1,320
		Width	mm	1,250	1,450	1,450	1,450	2,100
		Depth	mm	1,680	1,680	1,680	1,680	1,938
Condensor	Weight	Unit	kg	320	385	415	440	700
Heat Exchanger	Dimensions	Face Area	m ²	1.41	1.41	1.42	1.42	2 x 1.25
Condensor	Air Flow Rate	Cooling	m ³ /min	127	160	160	283	320
	Motor	Output	W	400	550	580	1,250	550
	Compressor	Quantity		1	1	1	1	2
Compressor	Motor	Type		Scroll type				
Operation Range	Cooling	Min	°CDB	20°C				
		Max	°CDB	46°C				
	Heating	Min	°CWB	-15°C				
		Max	°CWB	20°C				
Condensor	Sound Level (nominal)	Sound pressure	dBA	63	65	66	68	70
	Refrigerant	Type		R-407C				
		Charge	kg	4.3	5.2	6.0	6.0	2 x 5.0
		Control		Thermal expansion valve				
	Safety Devices			High pressure switch				
				Discharge thermostat setting				
	Notes			All specifications are subjected to change by the manufacturer without prior notice.				
				All units are being tested and comply to ISO5151.				
				Nominal cooling and heating capacity are based on the following conditions: cooling -27°CDB/19°CWB indoor and 35°CDB/24°CWB outdoor, heating -20°CDB indoor and 7°CDB/6°CWB outdoor.				
				Sound pressure levels are according to JIS B 8615 standard. Position of the measurement is 1m in front and 1m below the unit.				
			Designation based on cooling cycle.					

2 Specifications

2-2 Technical Specifications				UATYP560AMY1	UATYP700AMY1	UATYP850AMY1	UATYP10AMY1	UATYP12AMY1
Evaporator	Control	Air Discharge		Ducted				
		Operation		Sequential Controller				
	Air Flow Rate	Cooling	m ³ /min	190	226	263	312	354
	External Static Pressure		Pa	196	294	294	294	294
Piping connections	Condensation Drain Size	Diameter (OD)	mm	25.4	25.4	25.4	25.4	25.4
Condensor	Casing	Colour		Light Grey				
		Material		Electro galvanised mild steel				
Dimensions	Unit	Height	mm	1,200	1,735	1,735	1,974	1,974
		Width	mm	1,990	2,250	2,250	2,252	2,252
		Depth	mm	1,800	2,800	2,800	3,180	3,180
	Packing	Height	mm	1,320	1,900	1,900	2,150	2,150
		Width	mm	2,100	2,250	2,250	2,300	2,300
		Depth	mm	1,938	2,900	2,900	3,250	3,250
Condensor	Weight	Unit	kg	800	1,200	1,350	1,510	1,600
Heat Exchanger	Dimensions	Face Area	m ²	2 x 1.25	2 x 3.01	2 x 3.01	3.5	3.5
Condensor	Air Flow Rate	Cooling	m ³ /min	320	566	566	566	566
	Motor	Output	W	550	1,500	1,500	3,465	3,465
	Compressor	Quantity		2	2	2	2	2
Compressor	Motor	Type		Scroll type				
Operation Range	Cooling	Min	°CDB	20°C				
		Max	°CDB	46°C				
	Heating	Min	°CWB	-15°C				
		Max	°CWB	20°C				
Condensor	Sound Level (nominal)	Sound pressure	dBA	70	74	74	80	80
	Refrigerant	Type		R-407C				
		Charge	kg	2 x 5.8	2 x 9.4	2 x 9.6	13.5 & 20.0	2 x 20.0
		Control		Thermal expansion valve				
	Safety Devices			High pressure switch				
				Discharge thermostat setting	Discharge thermostat setting	Discharge thermostat setting	Phase sequencer	Phase sequencer
							Discharge thermostat setting	Discharge thermostat setting
	Notes	All specifications are subjected to change by the manufacturer without prior notice.						
		All units are being tested and comply to ISO5151.						
		Nominal cooling and heating capacity are based on the following conditions: cooling -27°CDB/19°CWB indoor and 35°CDB/24°CWB outdoor, heating -20°CDB indoor and 7°CDB/6°CWB outdoor.						
Sound pressure levels are according to JIS B 8615 standard. Position of the measurement is 1m in front and 1m below the unit.								
Designation based on cooling cycle.								

2-3 Electrical Specifications				UATYP180AMY1	UATYP240AMY1	UATYP280AMY1	UATYP320AMY1	UATYP450AMY1
Power Supply	Name			Y1				
	Phase			3-				
	Frequency		Hz	50	50	50	50	50
	Voltage		V	380-415				
Current	Nominal running current (RLA)	Cooling (A)	A	13.9	16.0	20.6	23.5	32.2
		Heating (A)	A	13.5	15.4	19.3	22.3	31.2

2 Specifications

2-3 Electrical Specifications			UATYP560AMY1	UATYP700AMY1	UATYP850AMY1	UATYPC10AMY1	UATYPC12AMY1
Power Supply	Name		Y1				
	Phase		3~				
	Frequency	Hz	50	50	50	50	50
	Voltage		V				
Current	Nominal running current (RLA)	Cooling (A)	39.9	52.1	65.5	74.2	82.9
		Heating (A)	38.4	48.6	61.9	72.0	81.1

3 Nomenclature

UATYP180AY1

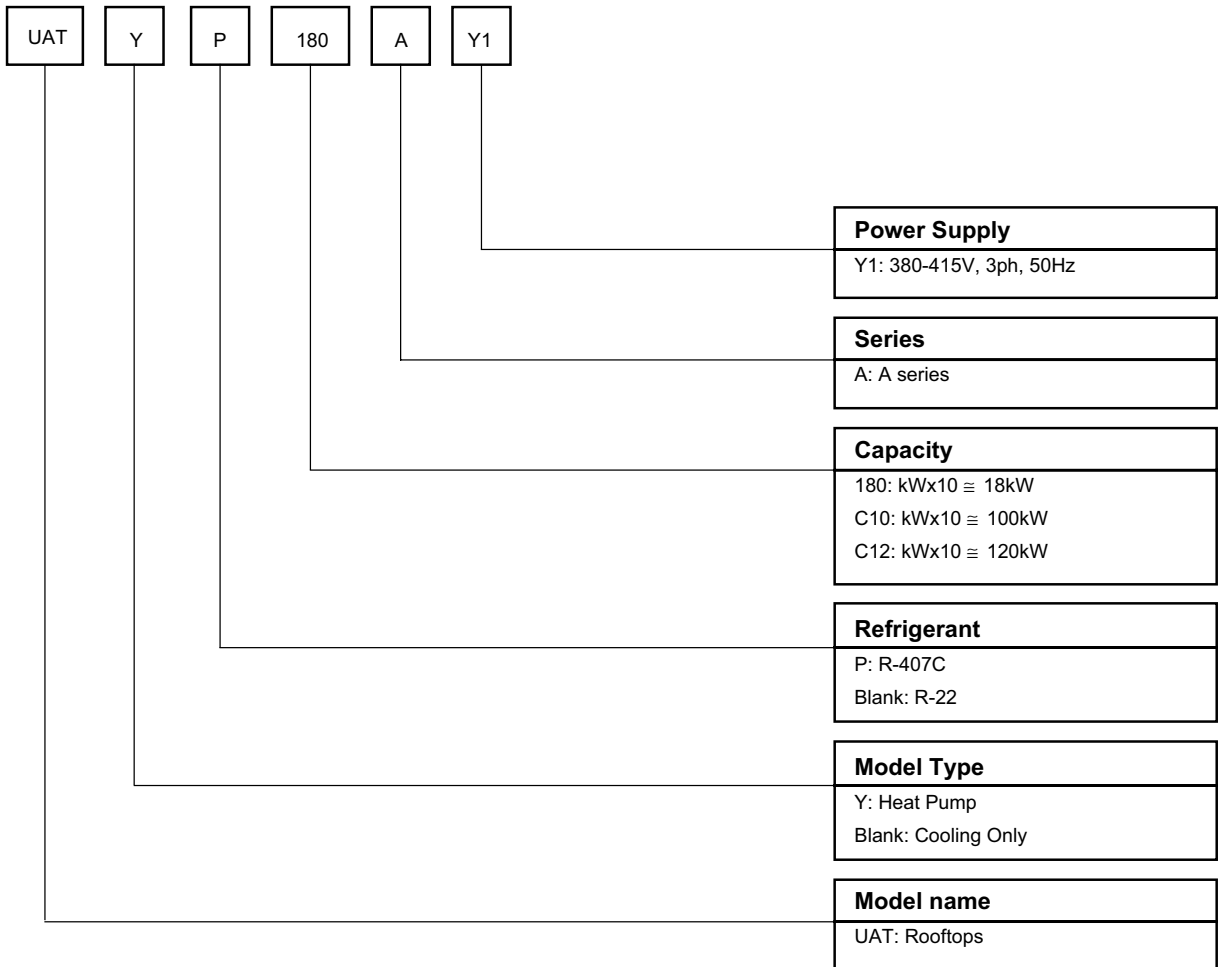

4 Features

UATYP		Classification												
	Model	SLM Controller	Seq. Controller	Capillary Tube	Thermal Expansion Valve (TXV)	Normal Fin	Anticorrosion treatment	Reciprocating compressor	Scroll Compressor	Air Filter	Down Flow	Side Flow	Convertible	Filter Drier
		Heat pump	UATYP180AY1	X			X		X		X	X		X
UATYP240AY1	X				X		X		X	X		X	X	X
UATYP280AY1	X				X		X		X	X		X	X	X
UATYP320AY1	X				X		X		X	X		X	X	X
UATYP450AY1			X		X		X		X	X		X	X	X
UATYP560AY1			X		X		X		X	X		X	X	X
UATYP700AY1			X		X		X		X	X		X		X
UATYP850AY1			X		X		X		X	X		X		X
UATYPC10AY1			X		X		X		X	X		X		X
UATYPC12AY1			X		X		X		X	X		X		X

5 Safety device settings

MODEL			UATYP180AY1	UATYP240AY1
SAFETY DEVICE	HIGH PRESSURE SWITCH	TYPE	NC	
		OPEN	kPa / psi	3241 / 470
		CLOSE	kPa / psi	2648 / 384
	LOW PRESSURE SWITCH	TYPE	N / A	
		OPEN	kPa / psi	N / A
		CLOSE	kPa / psi	N / A
	PHASE SEQUENCER			N / A
DISCHARGE THERMOSTAT SETTING			°C / °F 125 / 257	

MODEL			UATYP280AY1	UATYP320AY1
SAFETY DEVICE	HIGH PRESSURE SWITCH	TYPE	NC	
		OPEN	kPa / psi	3241 / 470
		CLOSE	kPa / psi	2648 / 384
	LOW PRESSURE SWITCH	TYPE	N / A	
		OPEN	kPa / psi	N / A
		CLOSE	kPa / psi	N / A
	PHASE SEQUENCER			N / A
DISCHARGE THERMOSTAT SETTING			°C / °F 125 / 257	

MODEL			UATYP450AY1	UATYP560AY1
SAFETY DEVICE	HIGH PRESSURE SWITCH	TYPE	NC	
		OPEN	kPa / psi	3241 / 470
		CLOSE	kPa / psi	2648 / 384
	LOW PRESSURE SWITCH	TYPE	N / A	
		OPEN	kPa / psi	N / A
		CLOSE	kPa / psi	N / A
	PHASE SEQUENCER			N / A
DISCHARGE THERMOSTAT SETTING			°C / °F 125 / 257	

MODEL			UATYP700AY1	UATYP850AY1
SAFETY DEVICE	HIGH PRESSURE SWITCH	TYPE	NC	
		OPEN	kPa / psi	3241 / 470
		CLOSE	kPa / psi	2648 / 384
	LOW PRESSURE SWITCH	TYPE	N / A	
		OPEN	kPa / psi	N / A
		CLOSE	kPa / psi	N / A
	PHASE SEQUENCER			N / A
DISCHARGE THERMOSTAT SETTING			°C / °F 125 / 257	

MODEL			UATYPC10AY1	UATYPC12AY1
SAFETY DEVICE	HIGH PRESSURE SWITCH	TYPE	NC	
		OPEN	kPa / psi	3241 / 470
		CLOSE	kPa / psi	2648 / 384
	LOW PRESSURE SWITCH	TYPE	N / A	
		OPEN	kPa / psi	N / A
		CLOSE	kPa / psi	N / A
	PHASE SEQUENCER			YES
DISCHARGE THERMOSTAT SETTING			°C / °F 125 / 257	

1) ALL SPECIFICATIONS ARE SUBJECTED TO CHANGE BY THE MANUFACTURER WITHOUT PRIOR NOTICE.

6 Control systems

Control Module Of Unit UATYP180AY1

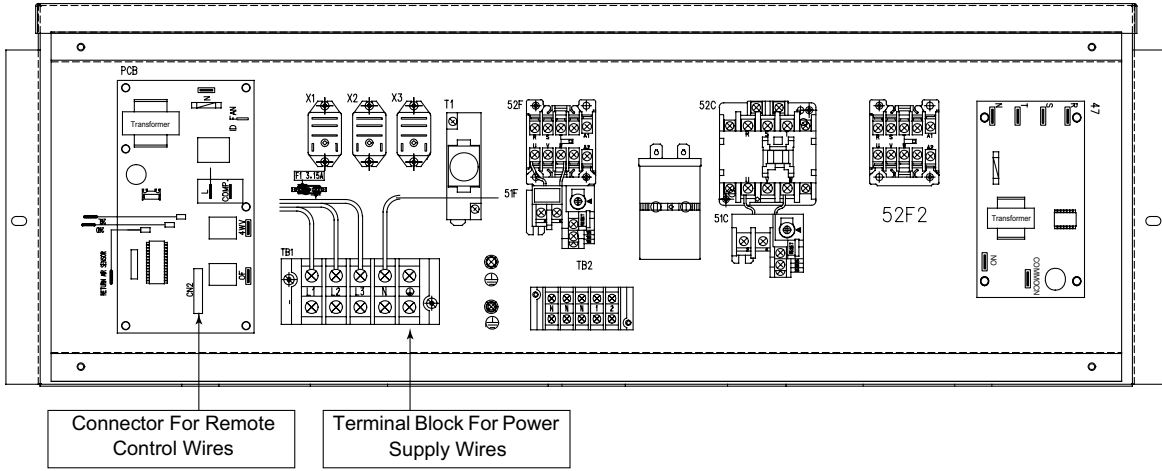

Control Module Of Unit UATYP240/280AY1

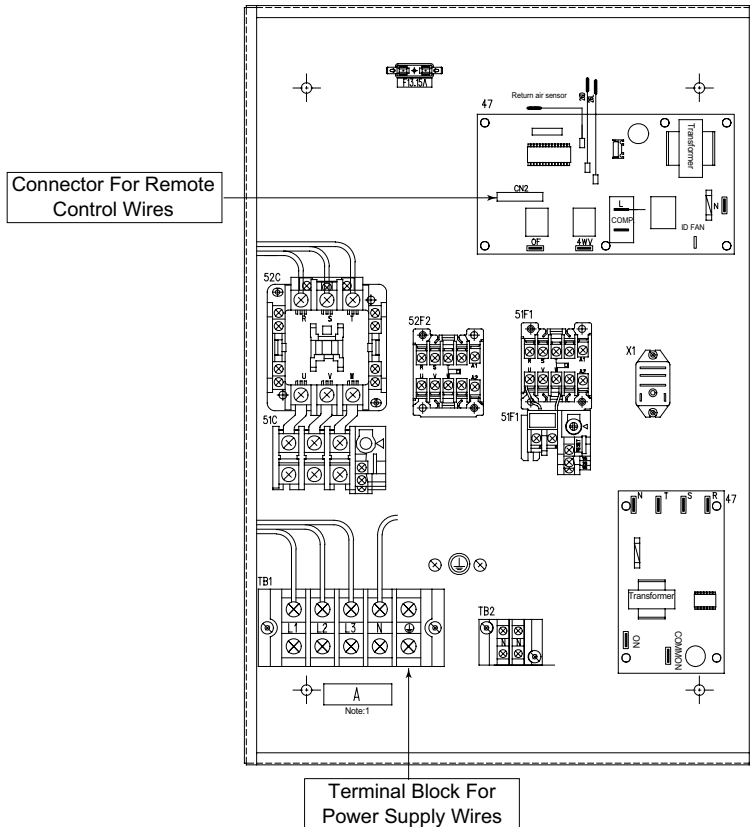

6 Control systems

Control Module Of Unit UATYP320AY1

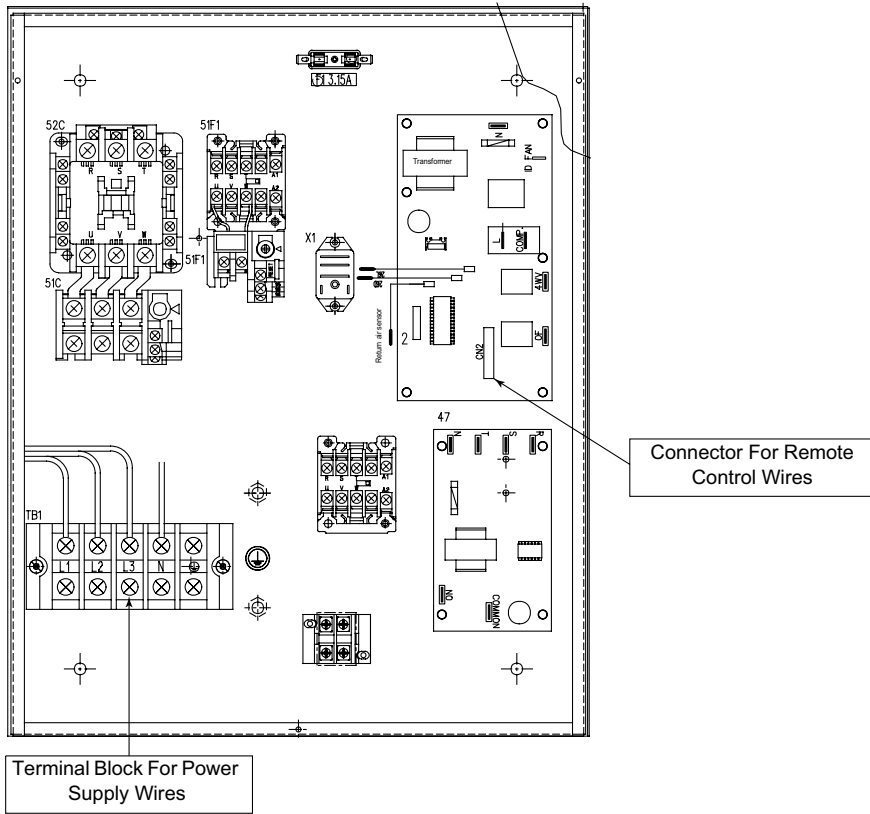

Control Module Of Unit UATYP450/560AY1

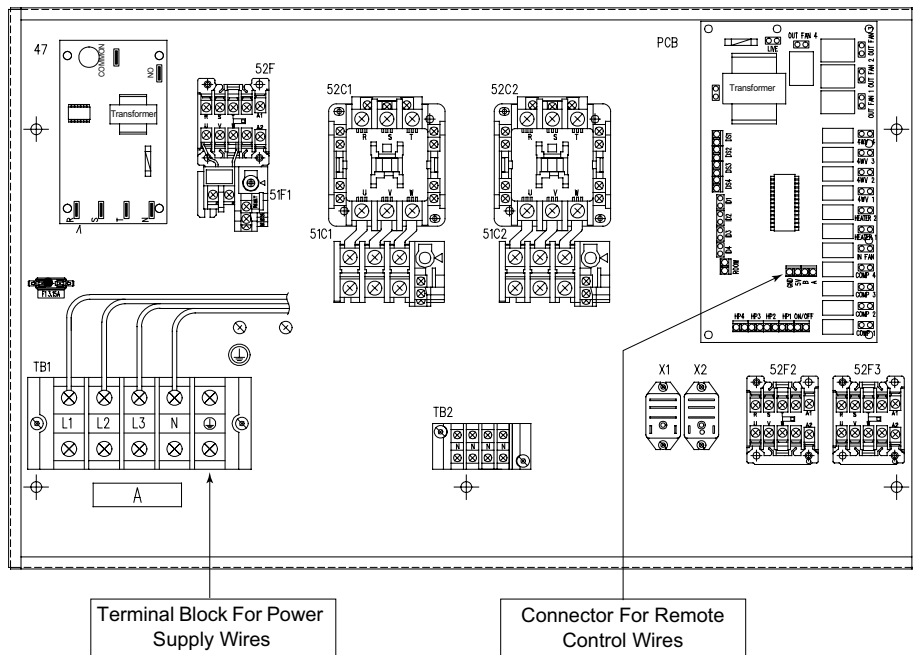

6 Control systems

Control Module Of Unit UATYP700/850AY1

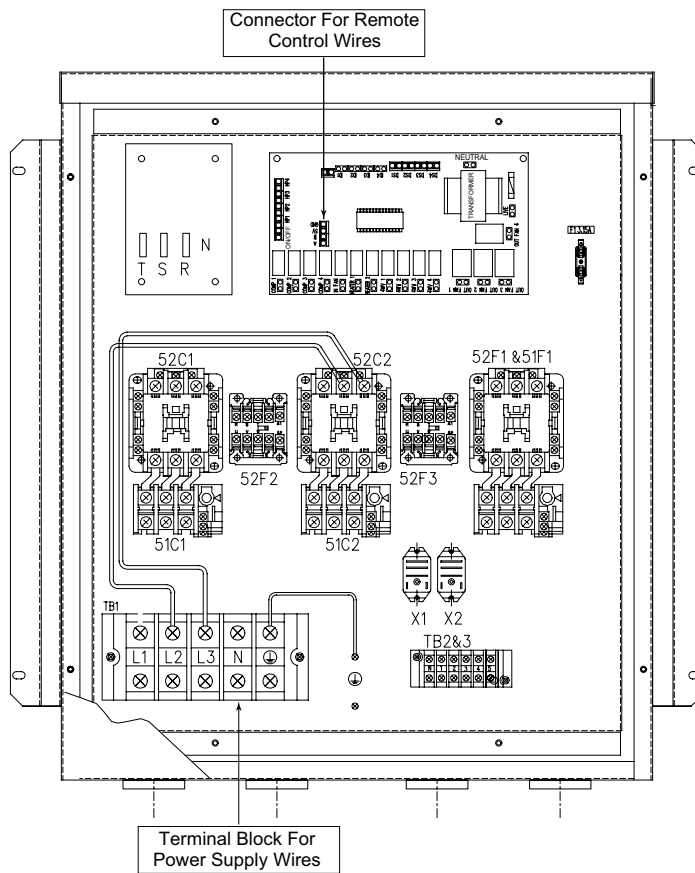

Control Module Of Unit UATYPC10/12AY1

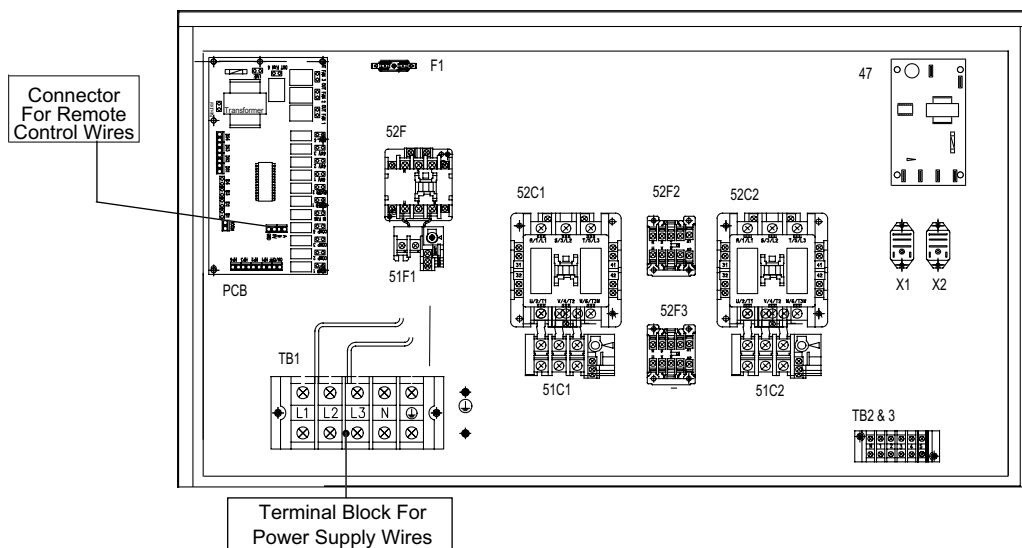

7 Capacity tables

7 - 1 Cooling capacity tables

SELECTION PROCEDURE

PERFORMANCE DATA

Performance table

Interpolation and extrapolation method can be used to get the total capacity, Q and sensible capacity, SC at those temperatures which are not stated out in the table.

Example:

Model: UAT700AY1

Indoor Condition: 23°C DB, 15°C WB

Outdoor condition: 37°C DB

Solution:

Overall

Based on the Performance table of UAT700AY1,

1. Refer to the indoor DB Column,
- 23°C is located between 20°C and 24°C (Thus, Interpolation need to be applied)
2. Refer to the indoor WB Column,
- 15°C only available in the case of indoor DB = 20°C. (Thus, extrapolation between 16°C WB and 17°C WB during 24°C indoor DB is required)
3. Refer to the indoor DB Column,
- 37°C is located between 35°C and 40°C. (Thus, Interpolation need to be applied)

Please follow the steps below in order to get the required capacity.

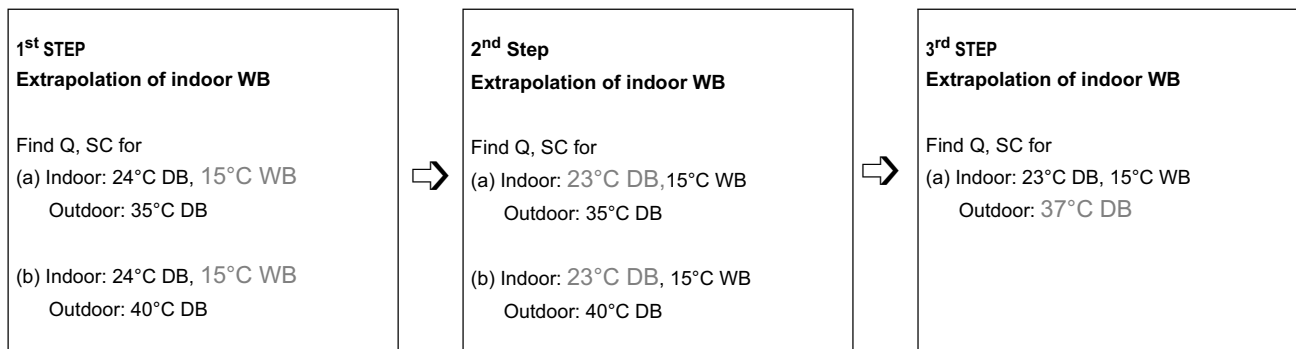

7 Capacity tables

7 - 1 Cooling capacity tables

Details:

1st Step:

To obtain the Total capacity and Sensible capacity for

(a) Indoor Condition: 24°C DB, 15°C WB

Outdoor Condition: 35°C DB

Indoor DB °C	Indoor WB °C	Outdoor DB°C	
		35	
		TC(kW)	SC(kW)
		!	!
24	15	x ₁	y ₁
	16	66.820	48.857
	17	68.717	47.070

Total capacity, Q

⇒ x₁ = 64.922 kW (Same as total capacity at 20°C Indoor DB / 15°C Indoor WB & 35°C Outdoor WB)*

Sensible capacity, Q

Extrapolation method:

$$\Rightarrow \frac{17^{\circ}\text{C} - 15^{\circ}\text{C}}{17^{\circ}\text{C} - 16^{\circ}\text{C}} = \frac{47.070\text{kW} - y_1}{47.070\text{kW} - 48.857\text{kW}}$$

⇒ y₁ = 50.644 kW

(b) Indoor Condition: 24°C DB, 15°C WB

Outdoor Condition: 40°C DB

Indoor DB °C	Indoor WB °C	Outdoor DB°C	
		40	
		TC(kW)	SC(kW)
		!	!
24	15	x ₁	y ₁
	16	61.569	45.442
	17	63.306	44.369

Total capacity, Q

⇒ x₂ = 59.831 kW (Same as total capacity at 20°C Indoor DB / 15°C Indoor WB & 40°C Outdoor WB)*

Sensible capacity, SC

Extrapolation method:

$$\Rightarrow \frac{17^{\circ}\text{C} - 15^{\circ}\text{C}}{17^{\circ}\text{C} - 16^{\circ}\text{C}} = \frac{47.369\text{kW} - y_1}{47.369\text{kW} - 45.422\text{kW}}$$

⇒ y₂ = 46.515 kW

*This is due to 2 different conditions with same WB temperature, will have the same level of enthalpy.
For more details, please refer to psychrometrics chart

7 Capacity tables

7 - 1 Cooling capacity tables

2nd Step:

To obtain the Total capacity and Sensible capacity for

(a) Indoor Condition: 23°C DB, 15°C WB

Outdoor Condition: 35°C DB

Indoor DB °C	Indoor WB °C	Outdoor DB°C	
		35	
		TC(kW)	SC(kW)
		!	!
20	15	64.922	35.494
23	15	x ₃	y ₃
24	15	64.922	50.644

Total capacity, Q

⇒ x₃ = 64.922 kW (Same as total capacity at 20°C Indoor DB / 15°C Indoor WB & 35°C Outdoor WB)*

Sensible capacity, Q

Extrapolation method:

$$\Rightarrow \frac{24^\circ\text{C} - 20^\circ\text{C}}{24^\circ\text{C} - 23^\circ\text{C}} = \frac{50.644\text{kW} - 35.494\text{kW}}{50.644\text{kW} - y_3}$$

⇒ y₃ = 46.857 kW

(b) Indoor Condition: 23°C DB, 15°C WB

Outdoor Condition: 40°C DB

Indoor DB °C	Indoor WB °C	Outdoor DB°C	
		40	
		TC(kW)	SC(kW)
		!	!
20	15	59.831	31.365
23	15	x ₄	y ₄
24	15	59.831	46.515

Total capacity, Q

⇒ x₄ = 59.831 kW (Same as total capacity at 20°C Indoor DB / 15°C Indoor WB & 40°C Outdoor WB)*

Sensible capacity, SC

Extrapolation method:

$$\Rightarrow \frac{24^\circ\text{C} - 20^\circ\text{C}}{24^\circ\text{C} - 23^\circ\text{C}} = \frac{46.515\text{kW} - 31.365\text{kW}}{46.515\text{kW} - y_4}$$

⇒ y₄ = 42.728 kW

*This is due to 2 different conditions with same WB temperature, will have the same level of enthalpy.
For more details, please refer to psychrometrics chart

7 Capacity tables

7 - 1 Cooling capacity tables

3rd Step:

To obtain the Total capacity and Sensible capacity for

(a) Indoor Condition: 23°C DB, 15°C WB

Outdoor Condition: 37°C DB

Indoor DB °C	Indoor WB °C	Outdoor DB°C					
		35		37		40	
		TC(kW)	SC(kW)	TC(kW)	SC(kW)	TC(kW)	SC(kW)
23	15	64.922	46.857	x	y	59.831	42.728

Total capacity, Q

Interpolation method:

$$\Rightarrow \frac{40^{\circ}\text{C} - 35^{\circ}\text{C}}{40^{\circ}\text{C} - 37^{\circ}\text{C}} = \frac{59.831\text{kW} - 64.922\text{kW}}{59.831\text{kW} - x}$$

$$\Rightarrow y = 62.886 \text{ kW}$$

Sensible capacity, SC

Interpolation method:

$$\Rightarrow \frac{40^{\circ}\text{C} - 35^{\circ}\text{C}}{40^{\circ}\text{C} - 37^{\circ}\text{C}} = \frac{42.728\text{kW} - 46.857\text{kW}}{42.728\text{kW} - y}$$

$$\Rightarrow y = 45.205 \text{ kW}$$

7 Capacity tables

7 - 1 Cooling capacity tables

UATYP180AY1

COOLING MODE

ID DB°C	ID WB°C	Outdoor DB°C											
		20		25		30		35		40		46	
		TC(kW)	SC(kW)	TC(kW)	SC(kW)	TC(kW)	SC(kW)	TC(kW)	SC(kW)	TC(kW)	SC(kW)	TC(kW)	SC(kW)
20	15	18.535	11.743	17.313	10.698	16.091	9.653	14.870	8.608	13.648	7.564	12.182	6.310
	16	19.198	10.684	17.898	9.722	16.598	8.760	15.299	7.798	13.999	6.836	12.440	5.682
24	16	19.198	13.608	17.898	12.646	16.598	11.684	15.299	10.722	13.999	9.760	12.440	8.606
	17	19.860	12.548	18.483	11.669	17.106	10.790	15.728	9.912	14.351	9.033	12.698	7.978
	18	20.523	11.489	19.068	10.693	17.613	9.897	16.157	9.101	14.702	8.305	12.956	7.350
	19	21.186	10.430	19.653	9.717	18.120	9.004	16.587	8.291	15.053	7.578	13.214	6.722
	20	21.854	9.374	20.289	8.773	18.724	8.171	17.159	7.569	15.594	6.968	13.715	6.246
28	18	20.523	14.413	19.068	13.617	17.613	12.821	16.157	12.025	14.702	11.229	12.956	10.274
	19	21.186	13.354	19.653	12.641	18.120	11.928	16.587	11.215	15.053	10.501	13.214	9.646
	20	21.854	12.298	20.289	11.696	18.724	11.095	17.159	10.493	15.594	9.892	13.715	9.170
	21	22.526	11.245	20.960	10.773	19.393	10.302	17.826	9.831	16.260	9.360	14.380	8.795
	22	23.198	10.191	21.630	9.850	20.062	9.510	18.494	9.169	16.926	8.828	15.044	8.420
	23	23.870	9.138	22.301	8.927	20.731	8.717	19.161	8.507	17.592	8.297	15.708	8.045
30	24	24.542	8.084	22.971	8.004	21.400	7.925	19.829	7.845	18.258	7.765	16.373	7.670
	20	21.854	13.760	20.289	13.158	18.724	12.557	17.159	11.955	15.594	11.354	13.715	10.632
	21	22.526	12.707	20.960	12.235	19.393	11.764	17.826	11.293	16.260	10.822	14.380	10.257
	22	23.198	11.653	21.630	11.312	20.062	10.972	18.494	10.631	16.926	10.290	15.044	9.882
	23	23.870	10.600	22.301	10.389	20.731	10.179	19.161	9.969	17.592	9.759	15.708	9.507
	24	24.542	9.546	22.971	9.466	21.400	9.387	19.829	9.307	18.258	9.227	16.373	9.132

UATYP240AY1

COOLING MODE

ID DB°C	ID WB°C	Outdoor DB°C											
		20		25		30		35		40		46	
		TC(kW)	SC(kW)	TC(kW)	SC(kW)	TC(kW)	SC(kW)	TC(kW)	SC(kW)	TC(kW)	SC(kW)	TC(kW)	SC(kW)
20	15	22.010	11.357	20.621	10.336	19.231	9.315	17.842	8.294	16.453	7.273	14.786	6.048
	16	24.004	10.646	22.197	9.542	20.390	8.438	18.583	7.334	16.776	6.230	14.608	4.905
24	16	24.004	15.229	22.197	14.125	20.390	13.020	18.583	11.916	16.776	10.812	14.608	9.487
	17	25.999	14.517	23.774	13.330	21.549	12.143	19.324	10.955	17.099	9.768	14.429	8.344
	18	27.993	13.806	25.350	12.535	22.708	11.265	20.065	9.995	17.422	8.724	14.251	7.200
	19	29.987	13.094	26.927	11.741	23.866	10.387	20.806	9.034	17.745	7.680	14.072	6.056
	20	32.004	12.396	28.708	11.070	25.411	9.744	22.115	8.418	18.819	7.092	14.864	5.500
28	18	27.993	18.388	25.350	17.118	22.708	15.848	20.065	14.577	17.422	13.307	14.251	11.783
	19	29.987	17.677	26.927	16.323	23.866	14.970	20.806	13.617	17.745	12.263	14.072	10.639
	20	32.004	16.979	28.708	15.653	25.411	14.327	22.115	13.000	18.819	11.674	14.864	10.083
	21	34.035	16.289	30.625	15.064	27.214	13.839	23.804	12.614	20.394	11.389	16.302	9.919
	22	36.065	15.600	32.541	14.476	29.017	13.352	25.493	12.228	21.969	11.104	17.740	9.755
	23	38.096	14.911	34.458	13.888	30.820	12.865	27.182	11.842	23.544	10.819	19.178	9.591
30	24	40.127	14.221	36.375	13.299	32.623	12.378	28.871	11.456	25.119	10.534	20.617	9.428
	20	32.004	19.270	28.708	17.944	25.411	16.618	22.115	15.292	18.819	13.966	14.864	12.374
	21	34.035	18.581	30.625	17.356	27.214	16.131	23.804	14.906	20.394	13.681	16.302	12.211
	22	36.065	17.891	32.541	16.767	29.017	15.643	25.493	14.519	21.969	13.395	17.740	12.047
	23	38.096	17.202	34.458	16.179	30.820	15.156	27.182	14.133	23.544	13.110	19.178	11.883
	24	40.127	16.513	36.375	15.591	32.623	14.669	28.871	13.747	25.119	12.825	20.617	11.719

7 Capacity tables

7 - 1 Cooling capacity tables

UATYP280AY1

COOLING MODE

ID DB°C	ID WB°C	Outdoor DB°C											
		20		25		30		35		40		46	
		TC(kW)	SC(kW)	TC(kW)	SC(kW)	TC(kW)	SC(kW)	TC(kW)	SC(kW)	TC(kW)	SC(kW)	TC(kW)	SC(kW)
20	15	27.668	16.064	25.977	14.416	24.287	12.769	22.596	11.122	20.906	9.475	18.877	7.498
	16	28.683	15.355	26.896	13.650	25.109	11.946	23.323	10.242	21.536	8.538	19.392	6.493
24	16	28.683	21.150	26.896	19.446	25.109	17.742	23.323	16.038	21.536	14.334	19.392	12.289
	17	29.698	20.441	27.815	18.680	25.932	16.919	24.049	15.158	22.166	13.397	19.906	11.284
	18	30.713	19.732	28.734	17.914	26.754	16.096	24.775	14.278	22.795	12.460	20.420	10.278
	19	31.728	19.023	29.652	17.148	27.577	15.273	25.501	13.398	23.425	11.523	20.934	9.273
	20	32.748	18.324	30.618	16.473	28.487	14.622	26.357	12.771	24.226	10.920	21.669	8.699
28	18	30.713	25.528	28.734	23.710	26.754	21.892	24.775	20.074	22.795	18.256	20.420	16.074
	19	31.728	24.819	29.652	22.944	27.577	21.069	25.501	19.194	23.425	17.319	20.934	15.069
	20	32.748	24.119	30.618	22.269	28.487	20.418	26.357	18.567	24.226	16.716	21.669	14.495
	21	33.772	23.427	31.614	21.654	29.456	19.881	27.298	18.108	25.141	16.335	22.551	14.208
	22	34.795	22.734	32.610	21.039	30.425	19.344	28.240	17.650	26.056	15.955	23.434	13.921
	23	35.819	22.041	33.606	20.424	31.394	18.808	29.182	17.191	26.970	15.574	24.316	13.634
30	24	36.842	21.348	34.603	19.810	32.364	18.271	30.124	16.732	27.885	15.194	25.198	13.347
	20	32.748	27.017	30.618	25.166	28.487	23.315	26.357	21.465	24.226	19.614	21.669	17.393
	21	33.772	26.324	31.614	24.552	29.456	22.779	27.298	21.006	25.141	19.233	22.551	17.106
	22	34.795	25.632	32.610	23.937	30.425	22.242	28.240	20.547	26.056	18.853	23.434	16.819
	23	35.819	24.939	33.606	23.322	31.394	21.705	29.182	20.089	26.970	18.472	24.316	16.532
	24	36.842	24.246	34.603	22.707	32.364	21.169	30.124	19.630	27.885	18.092	25.198	16.245

UATYP320AY1

COOLING MODE

ID DB°C	ID WB°C	Outdoor DB°C											
		20		25		30		35		40		46	
		TC(kW)	SC(kW)	TC(kW)	SC(kW)	TC(kW)	SC(kW)	TC(kW)	SC(kW)	TC(kW)	SC(kW)	TC(kW)	SC(kW)
20	15	38.330	25.040	35.093	22.010	31.857	18.979	28.621	15.949	25.384	12.919	21.501	9.283
	16	38.716	23.109	35.450	20.237	32.183	17.364	28.917	14.491	25.651	11.619	21.731	8.171
24	16	38.716	29.522	35.450	26.649	32.183	23.777	28.917	20.904	25.651	18.031	21.731	14.584
	17	39.102	27.592	35.806	24.877	32.510	22.161	29.214	19.446	25.917	16.731	21.962	13.473
	18	39.489	25.662	36.163	23.104	32.836	20.546	29.510	17.988	26.184	15.430	22.192	12.361
	19	39.875	23.731	36.519	21.331	33.163	18.931	29.807	16.530	26.450	14.130	22.423	11.250
	20	40.279	21.812	37.031	19.659	33.784	17.507	30.536	15.354	27.289	13.202	23.392	10.619
28	18	39.489	32.074	36.163	29.517	32.836	26.959	29.510	24.401	26.184	21.843	22.192	18.774
	19	39.875	30.144	36.519	27.744	33.163	25.343	29.807	22.943	26.450	20.543	22.423	17.662
	20	40.279	28.225	37.031	26.072	33.784	23.920	30.536	21.767	27.289	19.615	23.392	17.032
	21	40.693	26.312	37.647	24.468	34.601	22.623	31.555	20.779	28.509	18.935	24.853	16.721
	22	41.107	24.400	38.262	22.864	35.418	21.327	32.573	19.791	29.728	18.255	26.315	16.411
	23	41.521	22.488	38.878	21.260	36.235	20.031	33.591	18.803	30.948	17.575	27.776	16.101
30	24	41.935	20.576	39.493	19.655	37.051	18.735	34.609	17.815	32.167	16.895	29.237	15.791
	20	40.279	31.431	37.031	29.278	33.784	27.126	30.536	24.973	27.289	22.821	23.392	20.238
	21	40.693	29.519	37.647	27.674	34.601	25.830	31.555	23.985	28.509	22.141	24.853	19.928
	22	41.107	27.606	38.262	26.070	35.418	24.534	32.573	22.997	29.728	21.461	26.315	19.617
	23	41.521	25.694	38.878	24.466	36.235	23.238	33.591	22.009	30.948	20.781	27.776	19.307
	24	41.935	23.782	39.493	22.862	37.051	21.942	34.609	21.021	32.167	20.101	29.237	18.997

7 Capacity tables

7 - 1 Cooling capacity tables

UATYP450AY1

COOLING MODE

ID DB°C	ID WB°C	Outdoor DB°C											
		20		25		30		35		40		46	
		TC(kW)	SC(kW)	TC(kW)	SC(kW)	TC(kW)	SC(kW)	TC(kW)	SC(kW)	TC(kW)	SC(kW)	TC(kW)	SC(kW)
20	15	49.421	33.248	45.957	29.932	42.494	26.617	39.030	23.302	35.566	19.987	31.410	16.009
	16	51.203	32.757	47.486	29.323	43.769	25.889	40.051	22.454	36.334	19.020	31.873	14.899
24	16	51.203	40.919	47.486	37.485	43.769	34.051	40.051	30.617	36.334	27.183	31.873	23.062
	17	52.986	40.429	49.015	36.876	45.044	33.322	41.072	29.769	37.101	26.216	32.335	21.952
	18	54.769	39.938	50.544	36.266	46.319	32.594	42.093	28.922	37.868	25.249	32.798	20.843
	19	56.552	39.447	52.073	35.656	47.594	31.865	43.114	28.074	38.635	24.283	33.260	19.733
	20	58.355	38.965	53.792	35.123	49.230	31.281	44.667	27.439	40.104	23.597	34.629	18.986
28	18	54.769	48.100	50.544	44.428	46.319	40.756	42.093	37.084	37.868	33.412	32.798	29.005
	19	56.552	47.610	52.073	43.819	47.594	40.027	43.114	36.236	38.635	32.445	33.260	27.896
	20	58.355	47.127	53.792	43.285	49.230	39.443	44.667	35.601	40.104	31.759	34.629	27.149
	21	60.172	46.650	55.639	42.803	51.107	38.955	46.574	35.108	42.042	31.260	36.602	26.643
	22	61.989	46.173	57.486	42.320	52.984	38.467	48.481	34.614	43.979	30.761	38.576	26.137
	23	63.806	45.696	59.333	41.837	54.861	37.979	50.388	34.120	45.916	30.262	40.549	25.632
30	24	65.622	45.219	61.180	41.355	56.738	37.491	52.295	33.627	47.853	29.763	42.522	25.126
	20	58.355	51.208	53.792	47.366	49.230	43.524	44.667	39.682	40.104	35.840	34.629	31.230
	21	60.172	50.731	55.639	46.884	51.107	43.036	46.574	39.189	42.042	35.341	36.602	30.724
	22	61.989	50.254	57.486	46.401	52.984	42.548	48.481	38.695	43.979	34.842	38.576	30.219
	23	63.806	49.777	59.333	45.919	54.861	42.060	50.388	38.202	45.916	34.343	40.549	29.713
24	65.622	49.300	61.180	45.436	56.738	41.572	52.295	37.708	47.853	33.844	42.522	29.207	

UATYP560AY1

COOLING MODE

ID DB°C	ID WB°C	Outdoor DB°C											
		20		25		30		35		40		46	
		TC(kW)	SC(kW)	TC(kW)	SC(kW)	TC(kW)	SC(kW)	TC(kW)	SC(kW)	TC(kW)	SC(kW)	TC(kW)	SC(kW)
20	15	56.583	34.633	53.494	32.278	50.406	29.923	47.317	27.569	44.228	25.214	40.522	22.389
	16	59.858	32.697	56.311	30.552	52.765	28.407	49.219	26.262	45.673	24.118	41.417	21.544
24	16	59.858	42.380	56.311	40.235	52.765	38.090	49.219	35.945	45.673	33.800	41.417	31.227
	17	63.133	40.444	59.129	38.509	55.125	36.574	51.121	34.639	47.117	32.704	42.312	30.382
	18	66.407	38.508	61.946	36.783	57.484	35.057	53.023	33.332	48.562	31.607	43.208	29.537
	19	69.682	36.572	64.763	35.057	59.844	33.541	54.925	32.026	50.006	30.510	44.103	28.692
	20	72.974	34.620	67.740	33.185	62.506	31.750	57.273	30.315	52.039	28.879	45.758	27.157
28	18	66.407	48.191	61.946	46.465	57.484	44.740	53.023	43.015	48.562	41.290	43.208	39.220
	19	69.682	46.255	64.763	44.739	59.844	43.224	54.925	41.708	50.006	40.193	44.103	38.375
	20	72.974	44.303	67.740	42.868	62.506	41.433	57.273	39.997	52.039	38.562	45.758	36.840
	21	76.277	42.341	70.824	40.900	65.371	39.458	59.917	38.017	54.464	36.575	47.920	34.845
	22	79.581	40.380	73.908	38.932	68.235	37.484	62.562	36.036	56.889	34.588	50.082	32.851
	23	82.884	38.418	76.992	36.964	71.099	35.509	65.207	34.055	59.314	32.601	52.243	30.856
30	24	86.187	36.456	80.075	34.996	73.963	33.535	67.851	32.074	61.739	30.614	54.405	28.861
	20	72.974	49.145	67.740	47.709	62.506	46.274	57.273	44.839	52.039	43.404	45.758	41.681
	21	76.277	47.183	70.824	45.741	65.371	44.300	59.917	42.858	54.464	41.416	47.920	39.687
	22	79.581	45.221	73.908	43.773	68.235	42.325	62.562	40.877	56.889	39.429	50.082	37.692
	23	82.884	43.259	76.992	41.805	71.099	40.351	65.207	38.897	59.314	37.442	52.243	35.697
24	86.187	41.297	80.075	39.837	73.963	38.376	67.851	36.916	61.739	35.455	54.405	33.703	

7 Capacity tables

7 - 1 Cooling capacity tables

UATYP700AY1

COOLING MODE

ID DB°C	ID WB°C	Outdoor DB°C											
		20		25		30		35		40		46	
		TC(kW)	SC(kW)	TC(kW)	SC(kW)	TC(kW)	SC(kW)	TC(kW)	SC(kW)	TC(kW)	SC(kW)	TC(kW)	SC(kW)
20	15	76.961	44.987	71.532	40.565	66.103	36.143	60.674	31.721	55.245	27.299	48.730	21.992
	16	79.502	41.628	73.736	37.785	67.970	33.942	62.205	30.098	56.439	26.255	49.520	21.643
24	16	79.502	56.843	73.736	52.999	67.970	49.156	62.205	45.313	56.439	41.470	49.520	36.858
	17	82.043	53.483	75.940	50.219	69.838	46.955	63.735	43.690	57.633	40.426	50.310	36.509
	18	84.583	50.124	78.144	47.439	71.705	44.753	65.266	42.068	58.827	39.383	51.100	36.160
	19	87.124	46.765	80.348	44.658	73.573	42.552	66.797	40.445	60.021	38.339	51.890	35.811
	20	89.694	43.375	82.827	41.590	75.961	39.805	69.094	38.020	62.227	36.236	53.987	34.094
28	18	84.583	65.339	78.144	62.653	71.705	59.968	65.266	57.283	58.827	54.597	51.375	51.375
	19	87.124	61.979	80.348	59.873	73.573	57.766	66.797	55.660	60.021	53.554	51.890	51.026
	20	89.694	58.589	82.827	56.805	75.961	55.020	69.094	53.235	62.227	51.450	53.987	49.308
	21	92.284	55.179	85.490	53.544	78.696	51.909	71.902	50.275	65.108	48.640	56.955	46.679
	22	94.874	51.768	88.153	50.284	81.431	48.799	74.710	47.315	67.988	45.830	59.923	44.049
	23	97.464	48.357	90.815	47.023	84.166	45.689	77.518	44.355	70.869	43.020	62.891	41.419
30	20	89.694	66.197	82.827	64.412	75.961	62.627	69.094	60.842	62.227	59.057	56.916	56.916
	21	92.284	62.786	85.490	61.151	78.696	59.517	71.902	57.882	65.108	56.247	56.955	54.286
	22	94.874	59.375	88.153	57.891	81.431	56.406	74.710	54.922	67.988	53.438	59.923	51.656
	23	97.464	55.965	90.815	54.630	84.166	53.296	77.518	51.962	70.869	50.628	62.891	49.026
	24	100.053	52.554	93.478	51.370	86.902	50.186	80.326	49.002	73.750	47.818	65.859	46.397

UATYP850AY1

COOLING MODE

ID DB°C	ID WB°C	Outdoor DB°C											
		20		25		30		35		40		46	
		TC(kW)	SC(kW)	TC(kW)	SC(kW)	TC(kW)	SC(kW)	TC(kW)	SC(kW)	TC(kW)	SC(kW)	TC(kW)	SC(kW)
20	15	94.412	57.240	87.752	51.529	81.092	45.818	74.433	40.107	67.773	34.396	59.782	27.543
	16	97.877	54.492	90.707	49.133	83.537	43.775	76.367	38.416	69.197	33.057	60.593	26.627
24	16	97.877	72.604	90.707	67.245	83.537	61.887	76.367	56.528	69.197	51.169	60.593	44.739
	17	101.342	69.856	93.662	64.850	85.981	59.843	78.301	54.837	70.620	49.830	61.404	43.822
	18	104.807	67.109	96.616	62.454	88.426	57.800	80.235	53.145	72.044	48.491	62.215	42.906
	19	108.272	64.361	99.571	60.059	90.870	55.756	82.169	51.454	73.468	47.152	63.026	41.989
	20	111.779	61.592	102.909	57.470	94.040	53.347	85.170	49.224	76.301	45.101	65.658	40.154
28	18	104.807	85.221	96.616	80.566	88.426	75.912	80.235	71.258	72.044	66.603	62.215	61.018
	19	108.272	82.473	99.571	78.171	90.870	73.868	82.169	69.566	73.468	65.264	63.026	60.101
	20	111.779	79.704	102.909	75.582	94.040	71.459	85.170	67.336	76.301	63.214	65.658	58.266
	21	115.312	76.922	106.502	72.864	97.693	68.806	88.883	64.747	80.073	60.689	69.502	55.819
	22	118.846	74.140	110.096	70.146	101.346	66.152	92.596	62.158	83.846	58.164	73.346	53.371
	23	122.379	71.358	113.689	67.428	104.999	63.499	96.309	59.569	87.619	55.639	77.191	50.924
30	24	125.913	68.575	117.282	64.710	108.652	60.845	100.022	56.980	91.391	53.115	81.035	48.477
	20	111.779	88.761	102.909	84.638	94.040	80.515	85.170	76.392	76.301	72.270	67.322	67.322
	21	115.312	85.978	106.502	81.920	97.693	77.862	88.883	73.803	80.073	69.745	69.502	64.875
	22	118.846	83.196	110.096	79.202	101.346	75.208	92.596	71.214	83.846	67.220	73.346	62.428
	23	122.379	80.414	113.689	76.484	104.999	72.555	96.309	68.625	87.619	64.696	77.191	59.980
	24	125.913	77.631	117.282	73.766	108.652	69.901	100.022	66.036	91.391	62.171	81.035	57.533

7 Capacity tables

7 - 1 Cooling capacity tables

UATYPC10AY1

COOLING MODE

ID DB°C	ID WB°C	Outdoor DB°C											
		20		25		30		35		40		46	
		TC(kW)	SC(kW)	TC(kW)	SC(kW)	TC(kW)	SC(kW)	TC(kW)	SC(kW)	TC(kW)	SC(kW)	TC(kW)	SC(kW)
20	15	118.414	79.696	110.250	71.540	102.086	63.385	93.922	55.230	85.758	47.075	75.962	37.288
	16	120.123	76.359	112.096	68.349	104.068	60.340	96.040	52.330	88.013	44.320	78.380	34.708
24	16	120.123	96.174	112.096	88.165	104.068	80.155	96.040	72.145	88.013	64.135	78.380	54.523
	17	121.833	92.838	113.942	84.974	106.050	77.109	98.159	69.245	90.267	61.380	80.797	51.943
	18	123.543	89.501	115.787	81.783	108.032	74.064	100.277	66.345	92.522	58.626	83.215	49.363
	19	125.252	86.165	117.633	78.591	110.014	71.018	102.395	63.445	94.776	55.871	85.633	46.783
	20	126.971	82.840	119.565	75.507	112.160	68.175	104.754	60.842	97.348	53.509	88.461	44.710
28	18	123.543	109.317	115.787	101.598	108.032	93.879	100.277	86.160	92.522	78.441	83.215	69.178
	19	125.252	105.980	117.633	98.407	110.014	90.833	102.395	83.260	94.776	75.686	85.633	66.598
	20	126.971	102.655	119.565	95.322	112.160	87.990	104.754	80.657	97.348	73.324	88.461	64.525
	21	128.696	99.338	121.555	92.309	114.414	85.281	107.273	78.253	100.132	71.224	91.563	62.790
	22	130.421	96.020	123.545	89.296	116.669	82.572	109.792	75.848	102.916	69.124	94.665	61.055
	23	132.146	92.703	125.535	86.283	118.923	79.864	112.312	73.444	105.700	67.024	97.766	59.321
30	24	133.872	89.385	127.525	83.270	121.178	77.155	114.831	71.040	108.484	64.924	100.868	57.586
	20	126.971	112.563	119.565	105.230	112.160	97.897	104.754	90.565	97.348	83.232	88.461	74.433
	21	128.696	109.245	121.555	102.217	114.414	95.189	107.273	88.160	100.132	81.132	91.563	72.698
	22	130.421	105.928	123.545	99.204	116.669	92.480	109.792	85.756	102.916	79.032	94.665	70.963
	23	132.146	102.610	125.535	96.191	118.923	89.771	112.312	83.351	105.700	76.932	97.766	69.228
24	133.872	99.293	127.525	93.178	121.178	87.062	114.831	80.947	108.484	74.832	100.868	67.493	

UATYPC12AY1

COOLING MODE

ID DB°C	ID WB°C	Outdoor DB°C											
		20		25		30		35		40		46	
		TC(kW)	SC(kW)	TC(kW)	SC(kW)	TC(kW)	SC(kW)	TC(kW)	SC(kW)	TC(kW)	SC(kW)	TC(kW)	SC(kW)
20	15	136.431	89.966	125.782	79.600	115.134	69.234	104.485	58.869	93.837	48.503	81.059	36.064
	16	138.448	85.937	127.690	75.721	116.933	65.506	106.175	55.290	95.418	45.074	82.509	32.815
24	16	138.448	109.723	127.690	99.507	116.933	89.291	106.175	79.076	95.418	68.860	82.509	56.601
	17	140.465	105.694	129.599	95.628	118.732	85.563	107.865	75.497	96.998	65.431	83.958	53.352
	18	142.482	101.665	131.507	91.749	120.531	81.834	109.555	71.918	98.579	62.002	85.408	50.103
	19	144.499	97.636	133.415	87.870	122.330	78.105	111.245	68.339	100.160	58.573	86.858	46.854
	20	146.561	93.635	135.741	84.250	124.921	74.865	114.100	65.480	103.280	56.096	90.296	44.834
28	18	142.482	125.451	131.507	115.535	120.531	105.620	109.555	95.704	98.579	85.788	85.408	73.889
	19	144.499	121.422	133.415	111.656	122.330	101.891	111.245	92.125	100.160	82.359	86.858	70.640
	20	146.561	117.421	135.741	108.036	124.921	98.651	114.100	89.266	103.280	79.881	90.296	68.620
	21	148.653	113.438	138.346	104.588	128.040	95.738	117.733	86.888	107.426	78.038	95.058	67.418
	22	150.745	109.455	140.952	101.140	131.159	92.825	121.366	84.510	111.573	76.195	99.821	66.216
	23	152.837	105.473	143.557	97.692	134.278	89.912	124.999	82.132	115.719	74.351	104.584	65.015
30	24	154.929	101.490	146.163	94.244	137.397	86.999	128.631	79.753	119.866	72.508	109.347	63.813
	20	146.561	129.314	135.741	119.929	124.921	110.544	114.100	101.159	103.280	91.774	90.296	80.513
	21	148.653	125.331	138.346	116.481	128.040	107.631	117.733	98.781	107.426	89.931	95.058	79.311
	22	150.745	121.348	140.952	113.033	131.159	104.718	121.366	96.403	111.573	88.088	99.821	78.109
	23	152.837	117.366	143.557	109.585	134.278	101.805	124.999	94.025	115.719	86.244	104.584	76.908
24	154.929	113.383	146.163	106.137	137.397	98.892	128.631	91.646	119.866	84.401	109.347	75.706	

7 Capacity tables

7 - 2 Heating capacity tables

UATYP180AY1

HEATING MODE

ID DB°C	Outdoor DB°C													
	-9		-6		-5		6		12		15		18	
	TC(kW)	SC(kW)	TC(kW)	SC(kW)	TC(kW)	SC(kW)	TC(kW)	SC(kW)	TC(kW)	SC(kW)	TC(kW)	SC(kW)	TC(kW)	SC(kW)
15	7.517	7.517	8.899	8.899	9.360	9.360	16.468	16.468	17.192	17.192	18.574	18.574	19.956	19.956
17	7.325	7.325	8.788	8.788	9.276	9.276	15.788	15.788	17.038	17.038	18.408	18.408	19.778	19.778
19	7.134	7.134	8.677	8.677	9.192	9.192	15.488	15.488	16.885	16.885	18.243	18.243	19.600	19.600
21	7.131	7.131	8.567	8.567	9.108	9.108	15.108	15.108	16.732	16.732	18.077	18.077	19.422	19.422
23	7.068	7.068	8.520	8.520	9.024	9.024	14.507	14.507	16.578	16.578	17.911	17.911	19.245	19.245
25	7.006	7.006	8.472	8.472	8.940	8.940	14.427	14.427	16.425	16.425	17.746	17.746	19.067	19.067
27	6.943	6.943	8.425	8.425	8.857	8.857	13.527	13.527	16.272	16.272	17.580	17.580	18.889	18.889

FROST REGION

UATYP240AY1

HEATING MODE

ID DB°C	Outdoor DB°C													
	-9		-6		-5		6		12		15		18	
	TC(kW)	SC(kW)	TC(kW)	SC(kW)	TC(kW)	SC(kW)	TC(kW)	SC(kW)	TC(kW)	SC(kW)	TC(kW)	SC(kW)	TC(kW)	SC(kW)
15	13.380	13.380	14.823	14.823	15.304	15.304	20.593	20.593	23.478	23.478	24.920	24.920	26.362	26.362
17	13.278	13.278	14.690	14.690	15.166	15.166	21.323	21.323	23.268	23.268	24.698	24.698	26.128	26.128
19	13.175	13.175	14.557	14.557	15.029	15.029	22.054	22.054	23.059	23.059	24.476	24.476	25.893	25.893
21	13.072	13.072	14.424	14.424	14.892	14.892	22.784	22.784	22.849	22.849	24.253	24.253	25.658	25.658
23	12.934	12.934	14.291	14.291	14.755	14.755	21.638	21.638	22.640	22.640	24.031	24.031	25.423	25.423
25	12.795	12.795	14.158	14.158	14.618	14.618	20.491	20.491	22.430	22.430	23.809	23.809	25.188	25.188
27	12.656	12.656	14.025	14.025	14.480	14.480	19.345	19.345	22.221	22.221	23.587	23.587	24.953	24.953

FROST REGION

7 Capacity tables

7 - 2 Heating capacity tables

UATYP280AY1

HEATING MODE

ID DB°C	Outdoor DB°C													
	-9		-6		-5		6		12		15		18	
	TC(kW)	SC(kW)	TC(kW)	SC(kW)	TC(kW)	SC(kW)	TC(kW)	SC(kW)	TC(kW)	SC(kW)	TC(kW)	SC(kW)	TC(kW)	SC(kW)
15	16.259	16.259	18.365	18.365	19.067	19.067	26.791	26.791	31.004	31.004	33.110	33.110	35.217	35.217
17	16.051	16.051	18.200	18.200	18.896	18.896	26.546	26.546	30.727	30.727	32.815	32.815	34.903	34.903
19	15.843	15.843	18.036	18.036	18.725	18.725	26.302	26.302	30.451	30.451	32.520	32.520	34.589	34.589
21	15.636	15.636	17.871	17.871	18.554	18.554	26.057	26.057	30.174	30.174	32.225	32.225	34.275	34.275
23	15.555	15.555	17.706	17.706	18.383	18.383	25.823	25.823	29.898	29.898	31.930	31.930	33.961	33.961
25	15.473	15.473	17.541	17.541	18.213	18.213	25.590	25.590	29.621	29.621	31.634	31.634	33.648	33.648
27	15.392	15.392	17.377	17.377	18.042	18.042	25.356	25.356	29.345	29.345	31.339	31.339	33.334	33.334

FROST REGION

UATYP320AY1

HEATING MODE

ID DB°C	Outdoor DB°C													
	-9		-6		-5		6		12		15		18	
	TC(kW)	SC(kW)	TC(kW)	SC(kW)	TC(kW)	SC(kW)	TC(kW)	SC(kW)	TC(kW)	SC(kW)	TC(kW)	SC(kW)	TC(kW)	SC(kW)
15	15.547	15.547	18.854	18.854	19.956	19.956	32.081	32.081	38.695	38.695	42.001	42.001	45.308	45.308
17	15.046	15.046	18.595	18.595	19.777	19.777	32.739	32.739	38.350	38.350	41.627	41.627	44.904	44.904
19	14.545	14.545	18.335	18.335	19.599	19.599	33.396	33.396	38.005	38.005	41.253	41.253	44.501	44.501
21	14.045	14.045	18.076	18.076	19.420	19.420	34.053	34.053	37.659	37.659	40.878	40.878	44.097	44.097
23	14.285	14.285	18.002	18.002	19.241	19.241	32.774	32.774	37.314	37.314	40.504	40.504	43.693	43.693
25	14.526	14.526	17.928	17.928	19.062	19.062	31.494	31.494	36.969	36.969	40.129	40.129	43.289	43.289
27	14.766	14.766	17.854	17.854	18.884	18.884	30.214	30.214	36.624	36.624	39.755	39.755	42.886	42.886

FROST REGION

7 Capacity tables

7 - 2 Heating capacity tables

UATYP450AY1

HEATING MODE

ID DB°C	Outdoor DB°C													
	-9		-6		-5		6		12		15		18	
	TC(kW)	SC(kW)	TC(kW)	SC(kW)	TC(kW)	SC(kW)	TC(kW)	SC(kW)	TC(kW)	SC(kW)	TC(kW)	SC(kW)	TC(kW)	SC(kW)
15	32.738	32.738	35.387	35.387	36.270	36.270	45.981	45.981	51.279	51.279	53.927	53.927	56.576	56.576
17	32.693	32.693	35.069	35.069	35.944	35.944	46.646	46.646	50.821	50.821	53.447	53.447	56.072	56.072
19	32.648	32.648	34.752	34.752	35.619	35.619	47.312	47.312	50.364	50.364	52.966	52.966	55.568	55.568
21	32.603	32.603	34.434	34.434	35.294	35.294	47.977	47.977	49.906	49.906	52.485	52.485	55.063	55.063
23	32.046	32.046	34.117	34.117	34.968	34.968	46.433	46.433	49.449	49.449	52.004	52.004	54.559	54.559
25	31.490	31.490	33.799	33.799	34.643	34.643	44.890	44.890	48.991	48.991	51.523	51.523	54.055	54.055
27	30.934	30.934	33.482	33.482	34.318	34.318	43.346	43.346	48.534	48.534	51.042	51.042	53.551	53.551

FROST REGION

UATYP560AY1

HEATING MODE

ID DB°C	Outdoor DB°C													
	-9		-6		-5		6		12		15		18	
	TC(kW)	SC(kW)	TC(kW)	SC(kW)	TC(kW)	SC(kW)	TC(kW)	SC(kW)	TC(kW)	SC(kW)	TC(kW)	SC(kW)	TC(kW)	SC(kW)
15	40.351	40.351	45.988	45.988	47.868	47.868	68.539	68.539	79.814	79.814	85.452	85.452	91.089	91.089
17	39.740	39.740	45.576	45.576	47.438	47.438	66.819	66.819	79.102	79.102	84.690	84.690	90.278	90.278
19	39.129	39.129	45.163	45.163	47.009	47.009	65.099	65.099	78.390	78.390	83.928	83.928	89.466	89.466
21	38.518	38.518	44.751	44.751	46.580	46.580	63.379	63.379	77.678	77.678	83.166	83.166	88.654	88.654
23	38.417	38.417	44.339	44.339	46.151	46.151	63.933	63.933	76.966	76.966	82.404	82.404	87.842	87.842
25	38.316	38.316	43.926	43.926	45.722	45.722	64.487	64.487	76.254	76.254	81.642	81.642	87.030	87.030
27	38.215	38.215	43.514	43.514	45.293	45.293	65.041	65.041	75.542	75.542	80.881	80.881	86.219	86.219

FROST REGION

7 Capacity tables

7 - 2 Heating capacity tables

UATYP700AY1

HEATING MODE

ID DB°C	Outdoor DB°C													
	-9		-6		-5		6		12		15		18	
	TC(kW)	SC(kW)	TC(kW)	SC(kW)	TC(kW)	SC(kW)	TC(kW)	SC(kW)	TC(kW)	SC(kW)	TC(kW)	SC(kW)	TC(kW)	SC(kW)
15	44.020	44.020	48.982	48.982	50.635	50.635	68.829	68.829	78.752	78.752	83.714	83.714	88.676	88.676
17	43.631	43.631	48.544	48.544	50.181	50.181	70.798	70.798	78.050	78.050	82.968	82.968	87.885	87.885
19	43.243	43.243	48.106	48.106	49.727	49.727	72.767	72.767	77.347	77.347	82.221	82.221	87.095	87.095
21	42.855	42.855	47.669	47.669	49.273	49.273	74.736	74.736	76.645	76.645	81.475	81.475	86.305	86.305
23	42.452	42.452	47.228	47.228	48.819	48.819	71.401	71.401	75.942	75.942	80.728	80.728	85.515	85.515
25	42.049	42.049	46.786	46.786	48.365	48.365	68.067	68.067	75.239	75.239	79.982	79.982	84.724	84.724
27	41.646	41.646	46.345	46.345	47.911	47.911	64.732	64.732	74.537	74.537	79.235	79.235	83.934	83.934

FROST REGION

UATYP850AY1

HEATING MODE

ID DB°C	Outdoor DB°C													
	-9		-6		-5		6		12		15		18	
	TC(kW)	SC(kW)	TC(kW)	SC(kW)	TC(kW)	SC(kW)	TC(kW)	SC(kW)	TC(kW)	SC(kW)	TC(kW)	SC(kW)	TC(kW)	SC(kW)
15	56.416	56.416	64.113	64.113	66.678	66.678	94.898	94.898	110.291	110.291	117.987	117.987	125.684	125.684
17	55.606	55.606	63.462	63.462	66.080	66.080	94.039	94.039	109.307	109.307	116.935	116.935	124.564	124.564
19	54.795	54.795	62.811	62.811	65.483	65.483	93.180	93.180	108.323	108.323	115.884	115.884	123.444	123.444
21	53.984	53.984	62.160	62.160	64.885	64.885	92.321	92.321	107.340	107.340	114.832	114.832	122.324	122.324
23	53.797	53.797	61.665	61.665	64.287	64.287	91.486	91.486	106.356	106.356	113.780	113.780	121.203	121.203
25	53.610	53.610	61.170	61.170	63.690	63.690	90.650	90.650	105.372	105.372	112.728	112.728	120.083	120.083
27	53.423	53.423	60.675	60.675	63.092	63.092	89.815	89.815	104.388	104.388	111.676	111.676	118.963	118.963

FROST REGION

7 Capacity tables

7 - 2 Heating capacity tables

UATYPC10AY1

HEATING MODE

ID DB°C	Outdoor DB°C													
	-9		-6		-5		6		12		15		18	
	TC(kW)	SC(kW)	TC(kW)	SC(kW)	TC(kW)	SC(kW)	TC(kW)	SC(kW)	TC(kW)	SC(kW)	TC(kW)	SC(kW)	TC(kW)	SC(kW)
15	47.692	47.692	60.026	60.026	64.137	64.137	109.360	109.360	134.026	134.026	146.360	146.360	158.693	158.693
17	46.413	46.413	58.783	58.783	62.906	62.906	105.378	105.378	130.369	130.369	142.275	142.275	154.180	154.180
19	45.134	45.134	57.540	57.540	61.675	61.675	101.397	101.397	126.712	126.712	138.189	138.189	149.666	149.666
21	43.856	43.856	56.297	56.297	60.444	60.444	97.415	97.415	123.055	123.055	134.104	134.104	145.153	145.153
23	43.846	43.846	55.371	55.371	59.212	59.212	95.857	95.857	119.398	119.398	130.018	130.018	140.639	140.639
25	43.837	43.837	54.445	54.445	57.981	57.981	94.299	94.299	115.740	115.740	125.933	125.933	136.126	136.126
27	43.828	43.828	53.520	53.520	56.750	56.750	92.740	92.740	112.083	112.083	121.848	121.848	131.612	131.612

FROST REGION

UATYPC12AY1

HEATING MODE

ID DB°C	Outdoor DB°C													
	-9		-6		-5		6		12		15		18	
	TC(kW)	SC(kW)	TC(kW)	SC(kW)	TC(kW)	SC(kW)	TC(kW)	SC(kW)	TC(kW)	SC(kW)	TC(kW)	SC(kW)	TC(kW)	SC(kW)
15	51.341	51.341	64.544	64.544	68.945	68.945	117.357	117.357	143.764	143.764	156.967	156.967	170.170	170.170
17	49.983	49.983	63.213	63.213	67.624	67.624	116.572	116.572	139.842	139.842	152.586	152.586	165.330	165.330
19	48.624	48.624	61.882	61.882	66.302	66.302	115.786	115.786	135.919	135.919	148.205	148.205	160.490	160.490
21	47.265	47.265	60.551	60.551	64.980	64.980	115.000	115.000	131.997	131.997	143.824	143.824	155.651	155.651
23	47.238	47.238	59.553	59.553	63.658	63.658	109.660	109.660	128.075	128.075	139.443	139.443	150.811	150.811
25	47.211	47.211	58.555	58.555	62.337	62.337	104.321	104.321	124.153	124.153	135.062	135.062	145.971	145.971
27	47.184	47.184	57.557	57.557	61.015	61.015	98.981	98.981	120.231	120.231	130.681	130.681	141.131	141.131

FROST REGION

8 Dimensional drawing & centre of gravity

8 - 1 Dimensional drawing

UATYP180AY1

(unit: mm)

※ Except: Drain size. (unit: inch)

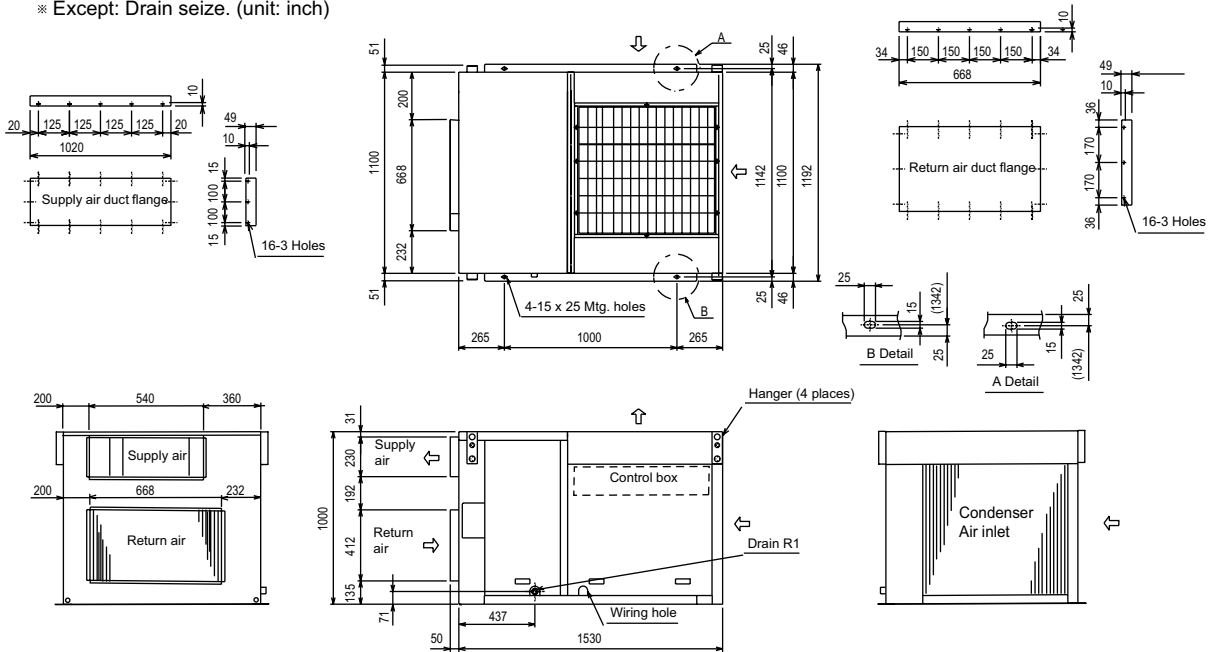

UATYP240/280/320AY1

(unit: mm)

※ Except: Drain size: (unit inch)

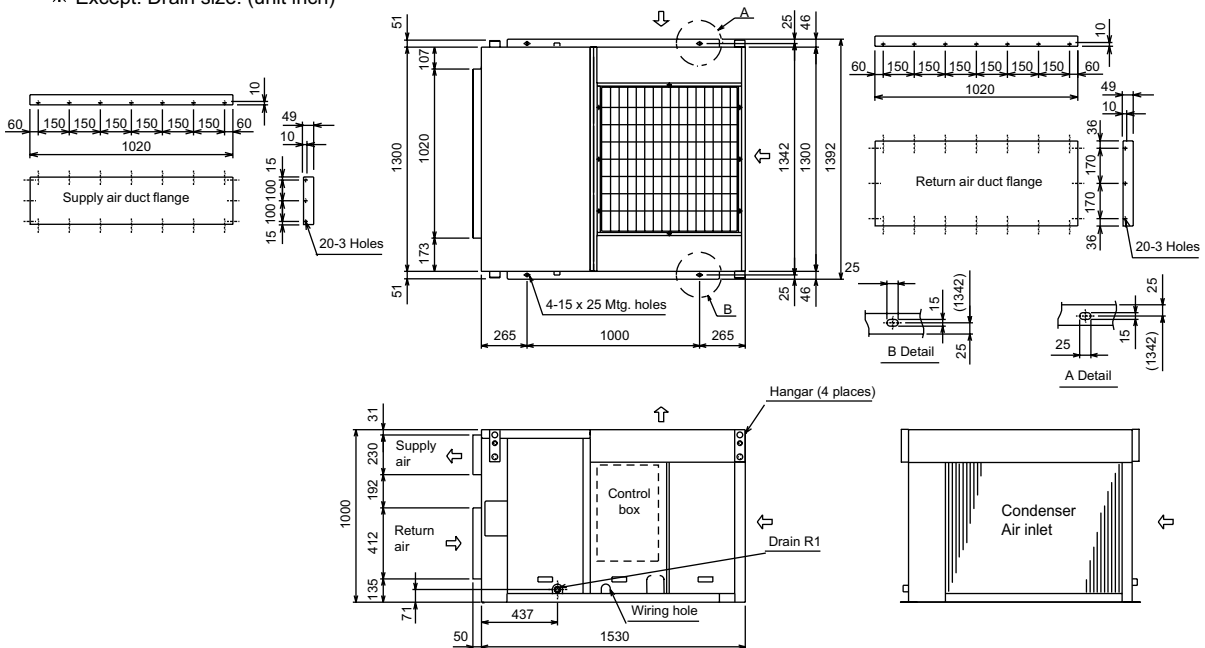

8 Dimensional drawing & centre of gravity

8 - 1 Dimensional drawing

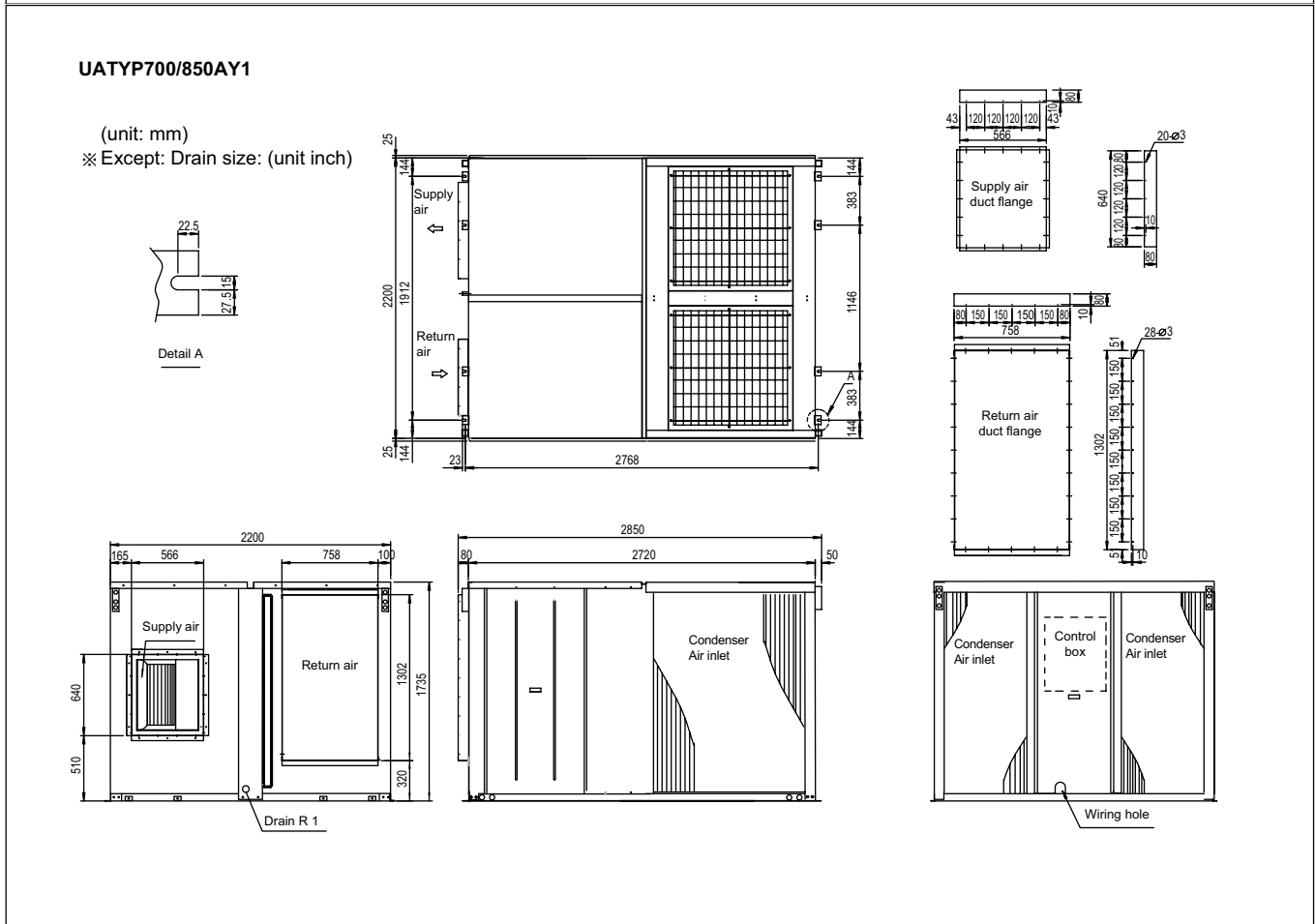
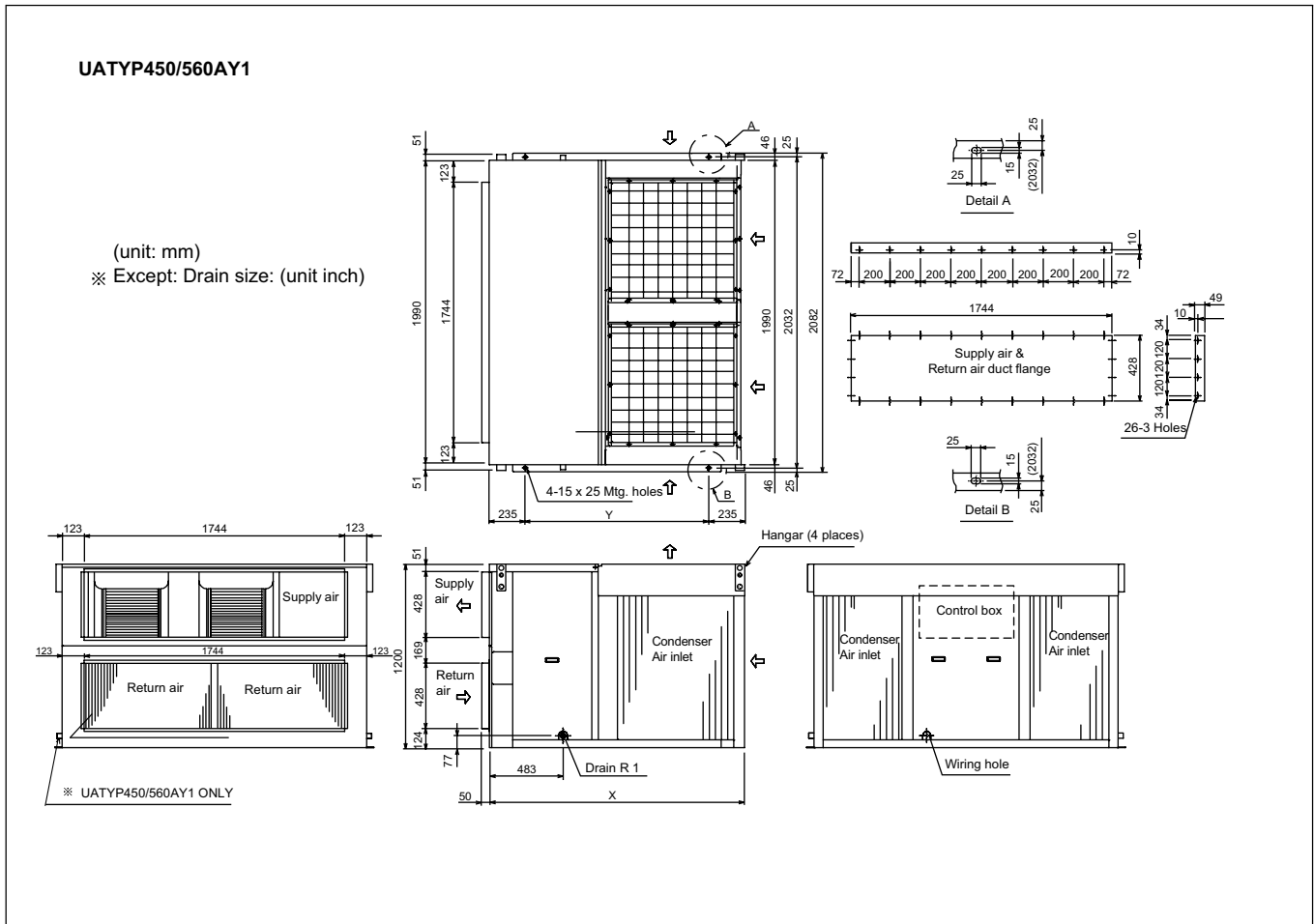

8 Dimensional drawing & centre of gravity

8 - 1 Dimensional drawing

UATYP10/C12AY1

(unit: mm)
 ※ Except: Drain size: (unit inch)

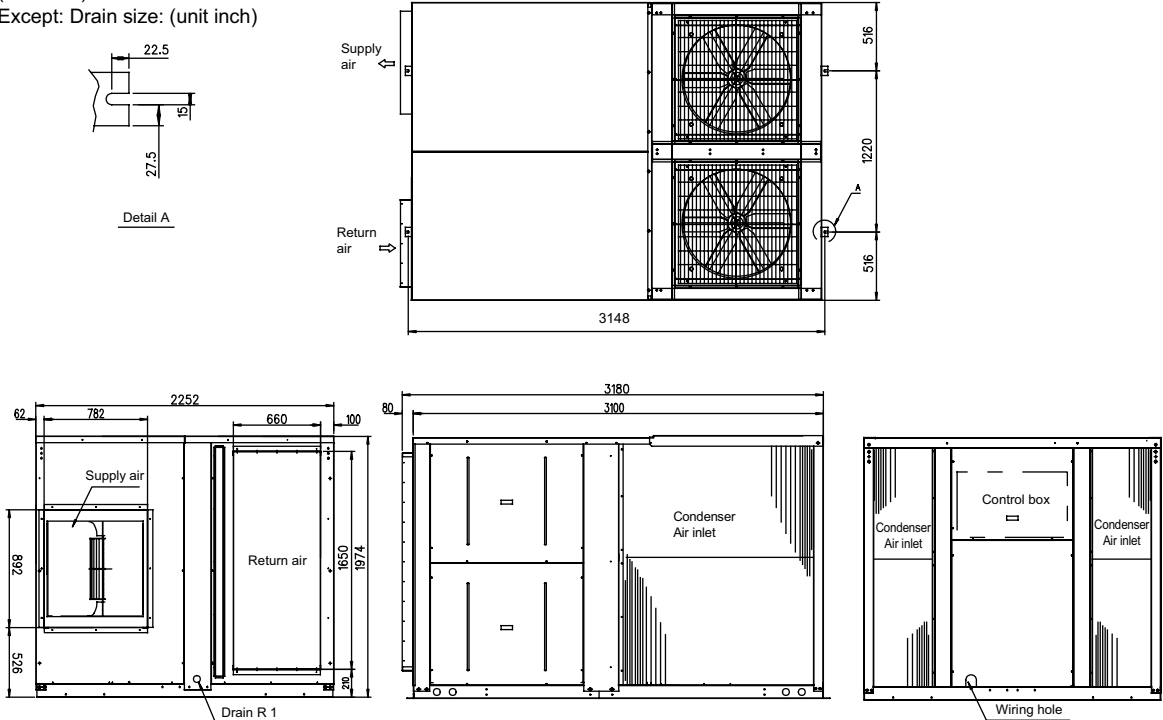

UATYP240/280/320AY1

(unit: mm)
 ※ Except: Drain size: (unit inch)

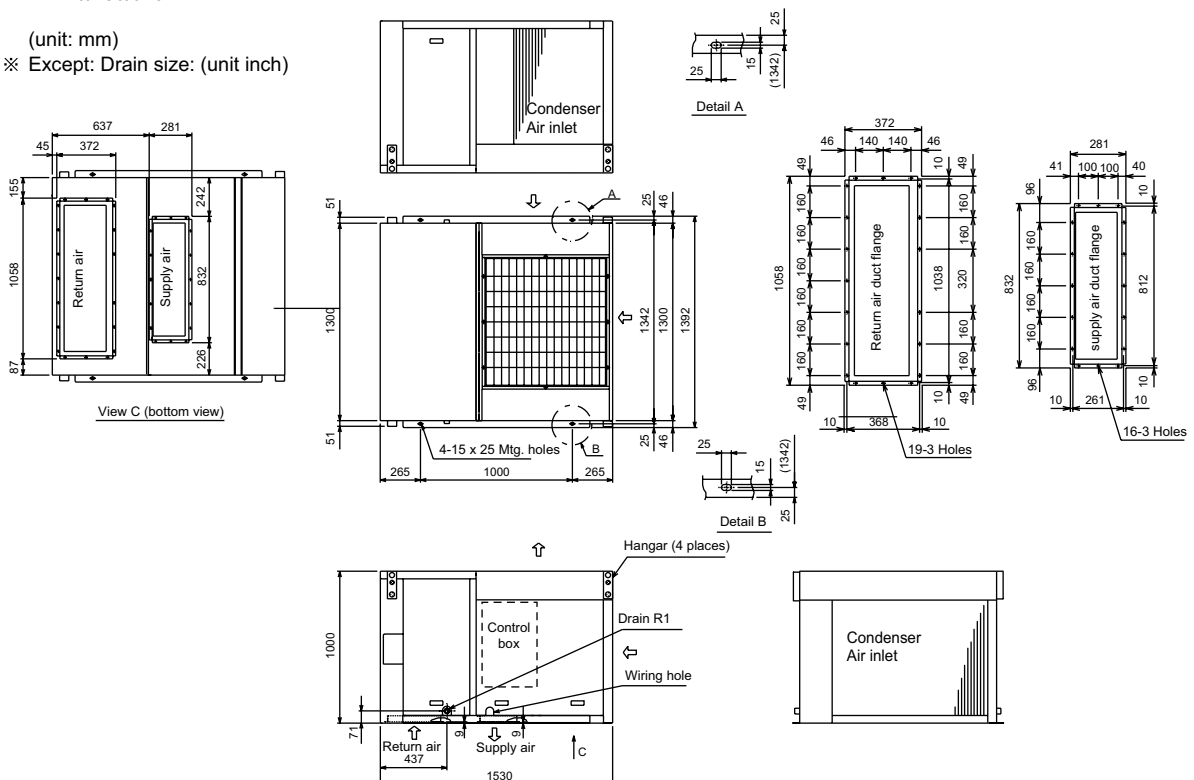

8 Dimensional drawing & centre of gravity

8 - 1 Dimensional drawing

UATYP450/560AY1

(unit: mm)

※ Except: Drain size: (unit inch)

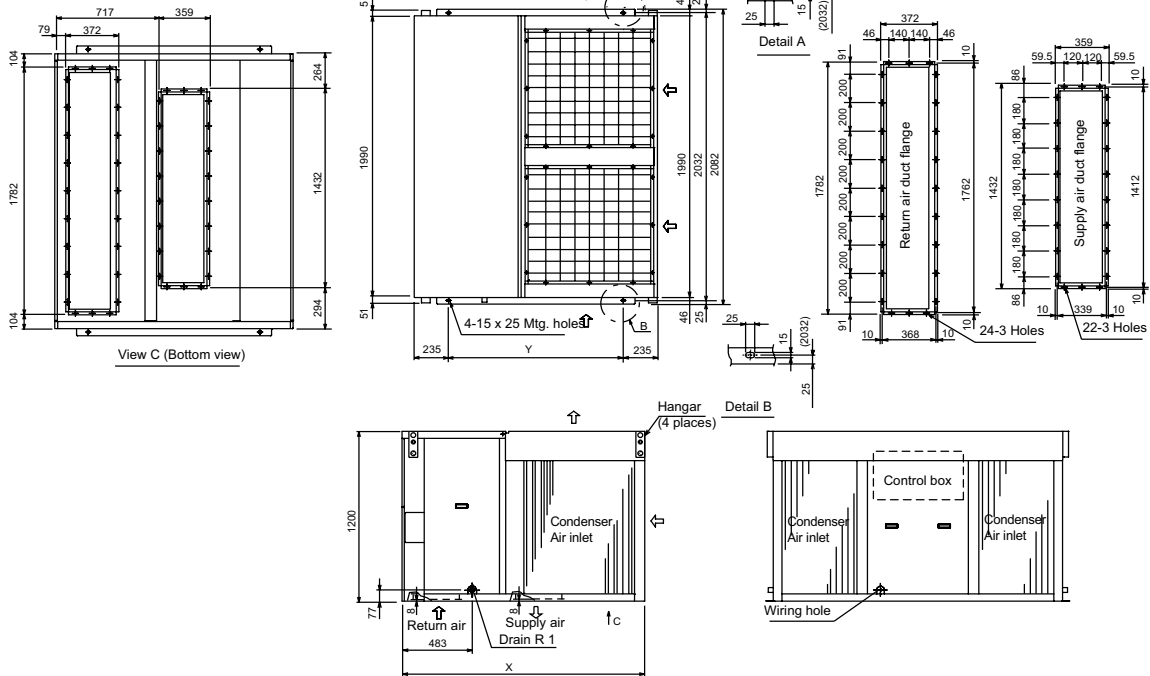

UATYP700/850AY1

(unit: mm)

※ Except: Drain size: (unit inch)

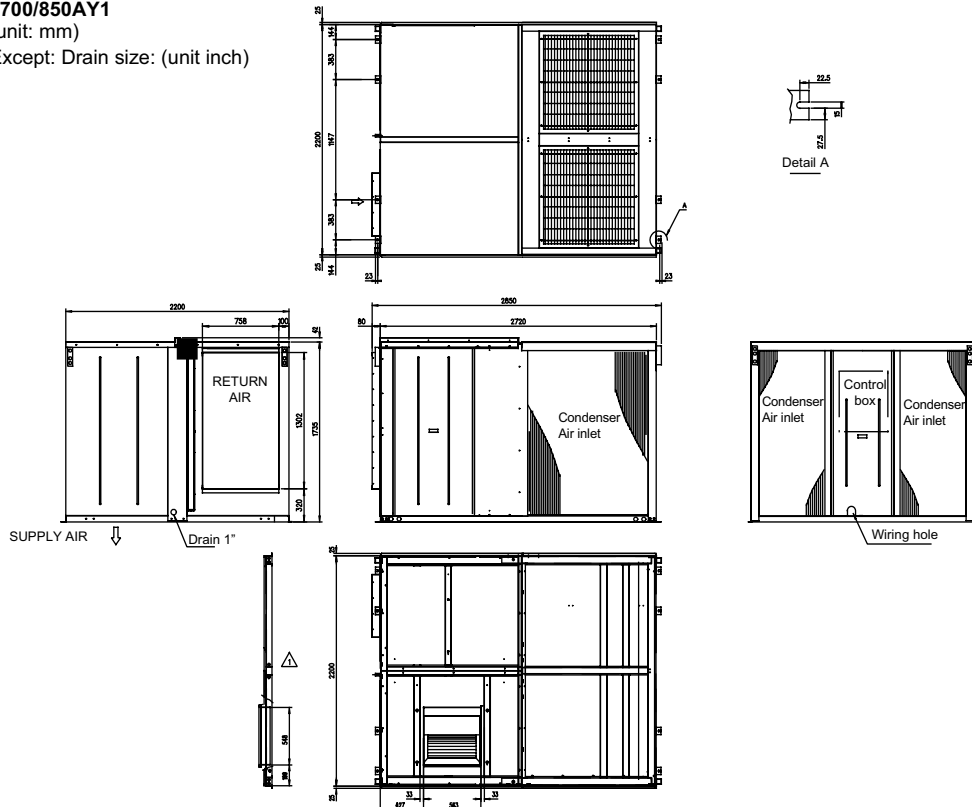

9 Piping diagram

UATYP180AY1

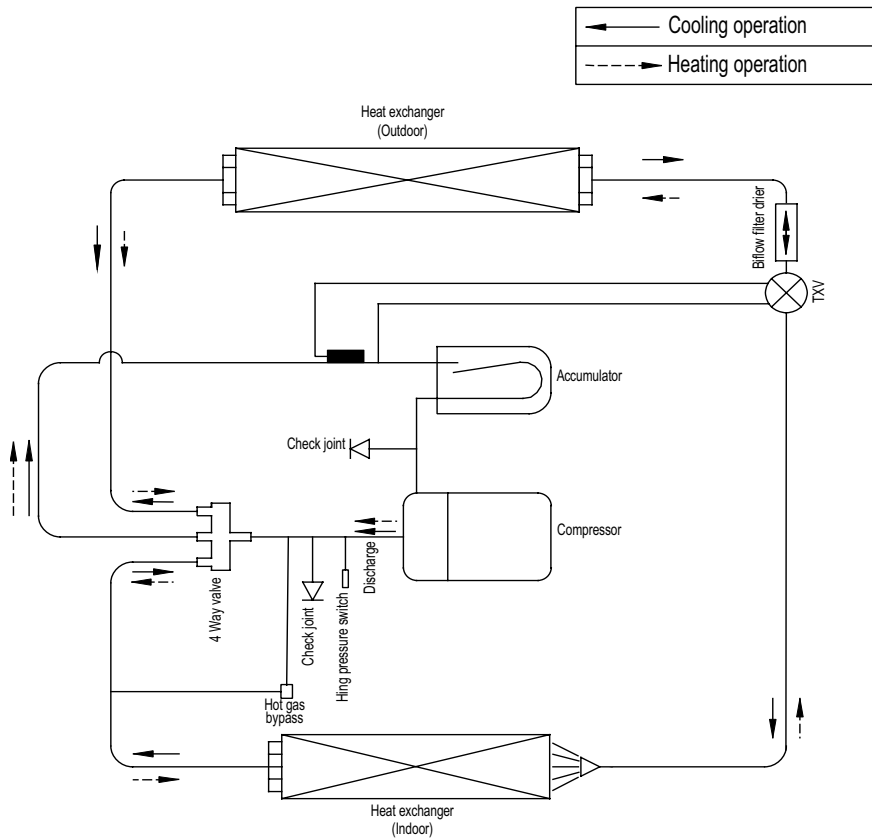

UATYP240/280AY1

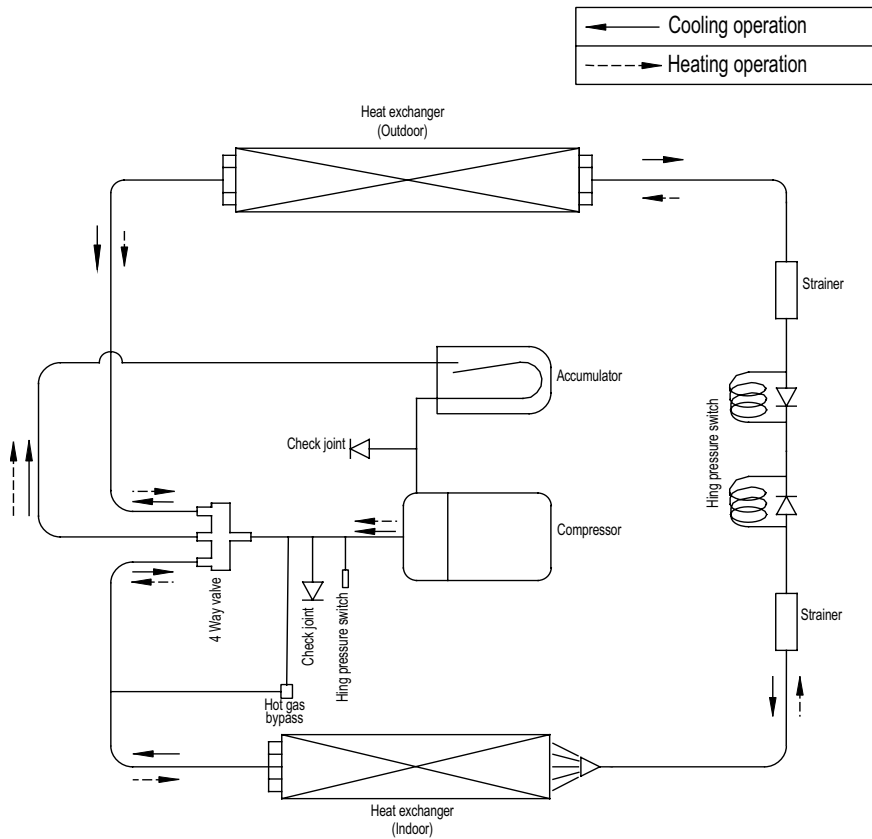

9 Piping diagram

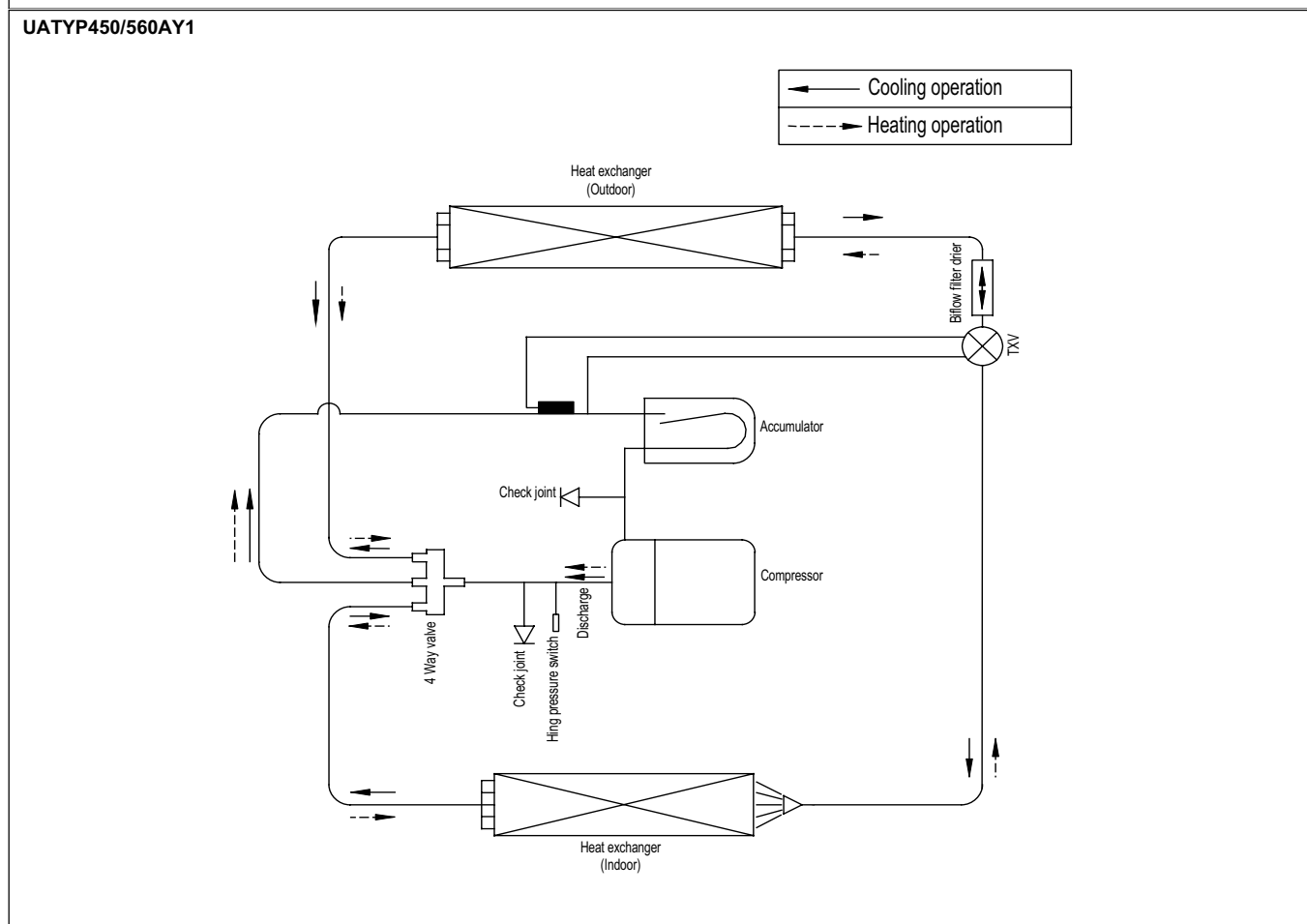
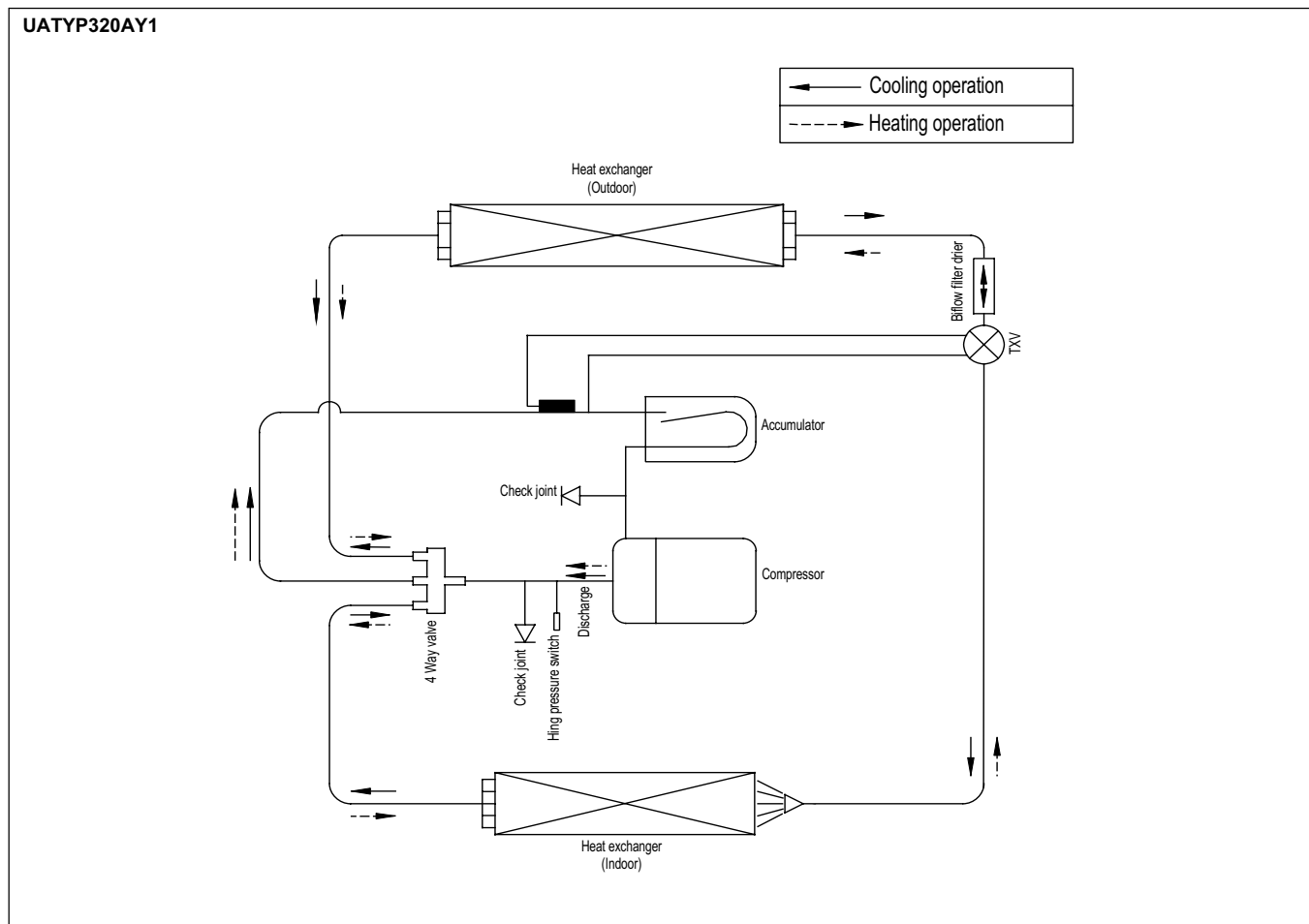

9 Piping diagram

UATYP700/850AY1

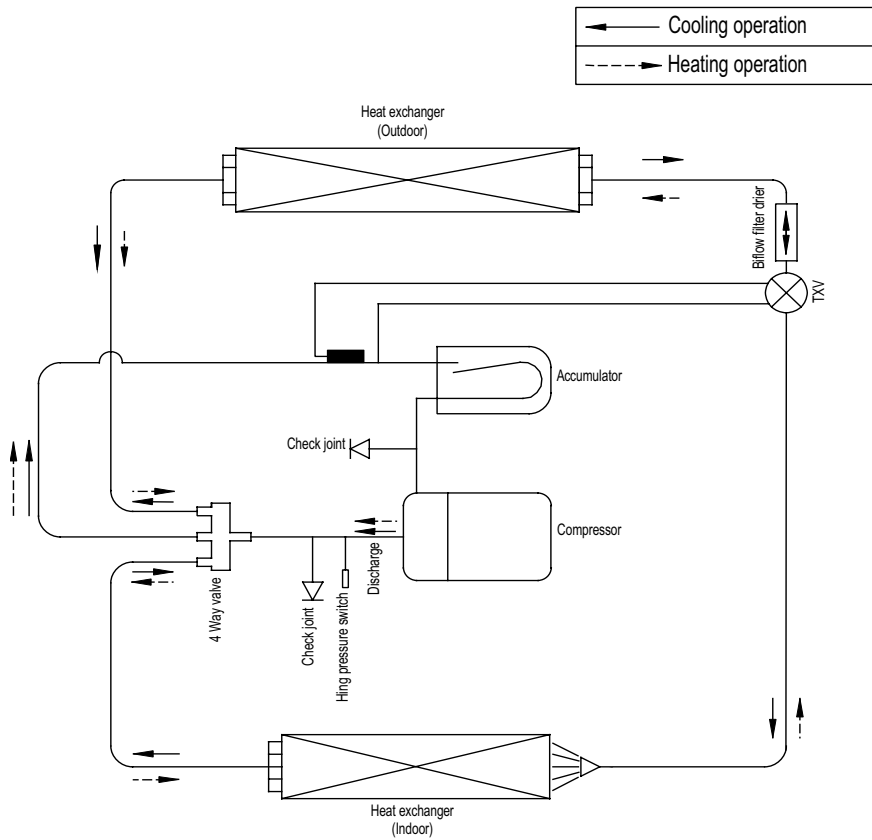

UATYPC10/12AY1

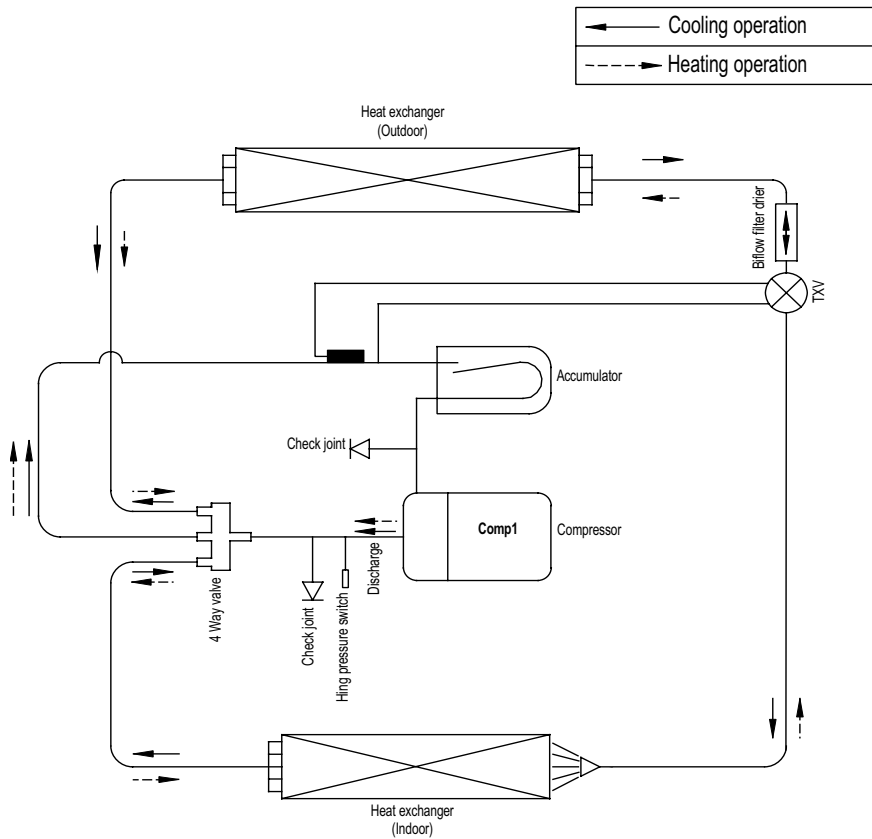

10 Wiring diagram

10 - 1 Wiring diagram

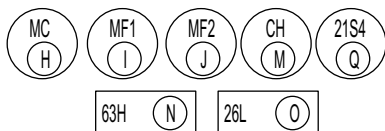
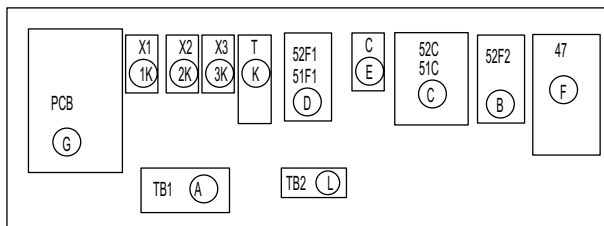
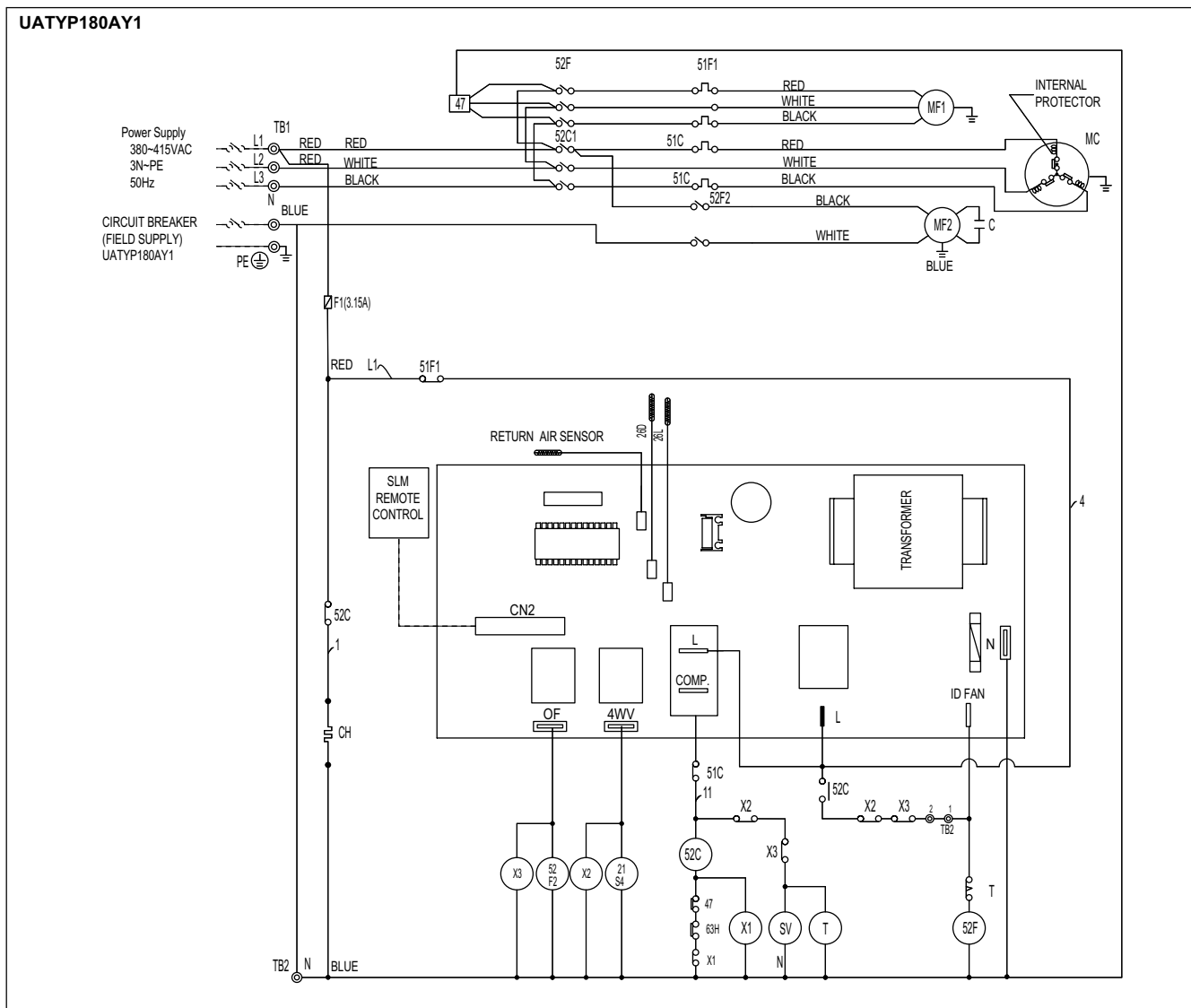

SYMBOL	NAME
MC	Compressor motor
MF1	Fan motor (indoor)
MF2	Fan motor (outdoor)
52C	Contactors (Compressor)
52F1	Contactors (fan I/D)
52F2	Contactors (fan O/D)
51C	Over current relay (comp)
TB1,2	Terminal block
51F1	Over current relay (fan I/D)
63H	High-pressure switch
CH	Crankcase heater
21S4	4-Way valve
26D	Sensor (defrost)
26L	Sensor (freeze protection)
PCB	Printed circuit board
47	Phase Protector / Discharge thermostat
X1, X3	Auxiliary Relay (Self hold)
X2, X3	Auxiliary Relay (Defrost)
T	Timer (Defrost)
SV	Solenoid Valve

Caution,

1. To protect each Fan motor and compressor from abnormal current, Over current relays <51C>, <51F> are installed. Therefore, do not change factory set value of Over current relays.

NOTES

- The dotted lines show field wiring.
- The figure in the parenthesis shows field supply parts.
- Color of earth is yellow and green twisting.

10 Wiring diagram

10 - 1 Wiring diagram

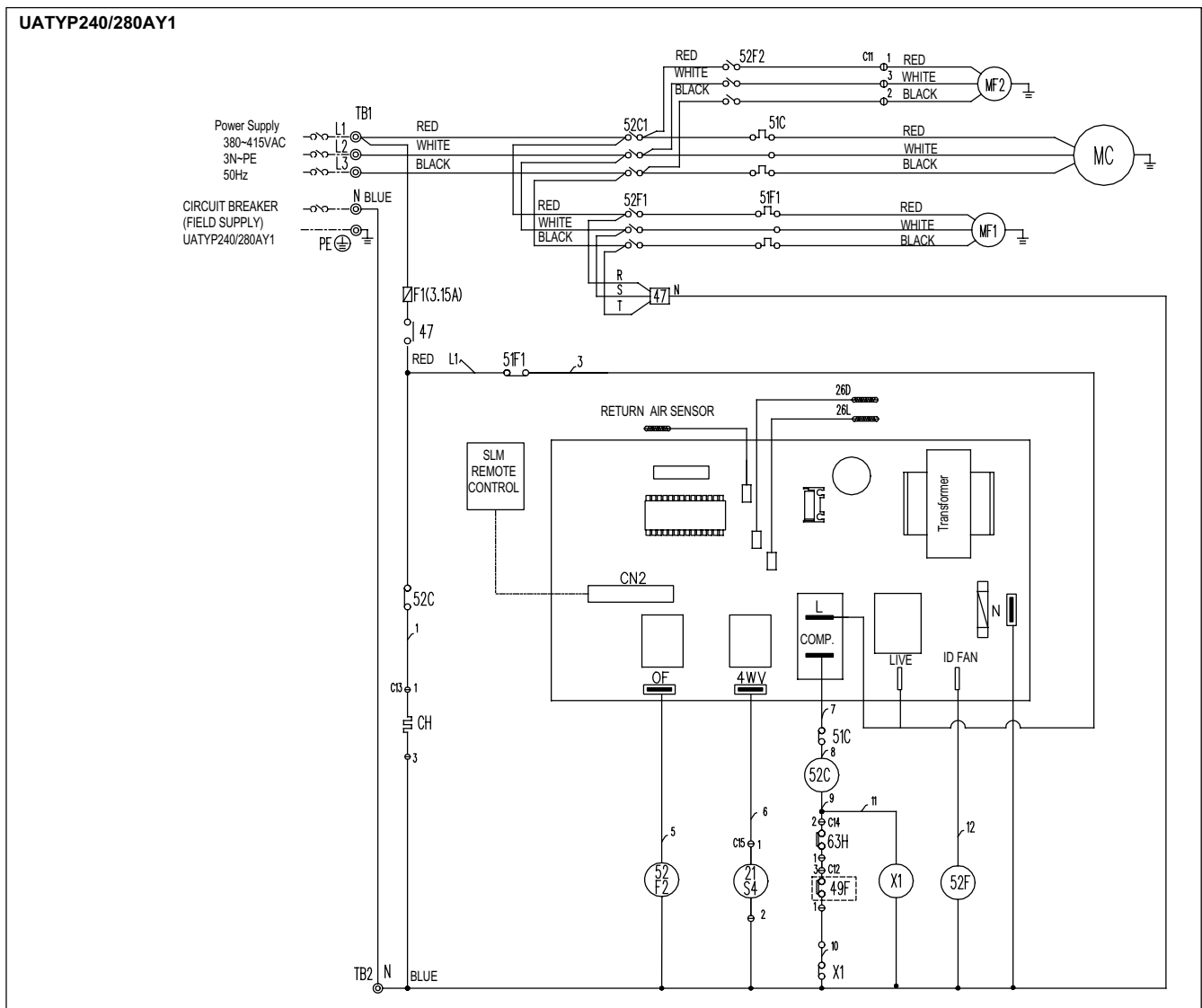

Arrangement

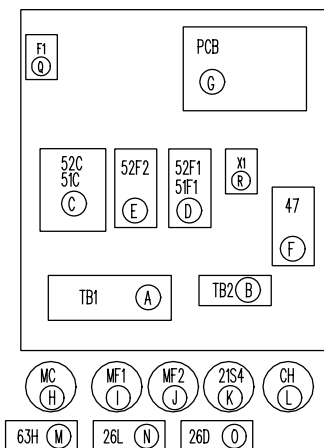

SYMBOL	NAME
MC	Compressor motor
MF1	Fan motor (indoor)
MF2	Fan motor (outdoor)
52C	Contactors (Compressor)
52F1	Contactors (fan I/D)
52F2	Contactors (fan O/D)
51C	Over current relay (comp)
51F1	Over current relay (fan I/D)
F1	Fuse (3.15A)
TB1,2	Terminal block
63H	High-pressure switch
CH	Crankcase heater
21S4	4-Way valve
26D	Sensor (defrost)
26L	Sensor (freeze protection)
PCB	Printed circuit board
47	Phase protector/Discharge thermostat
X1	Auxiliary relay (Self Hold)
49F	Internal Protector (OD Fan)

Caution,

- To protect each Fan motor and compressor from abnormal current, Over current relays <51C>, <51F> are installed. Therefore, do not change factory set value of Over current relays.

NOTES

- The dotted lines show field wiring.
- The figure in the parenthesis shows field supply parts.
- Color of earth is yellow and green twisting.

10 Wiring diagram

10 - 1 Wiring diagram

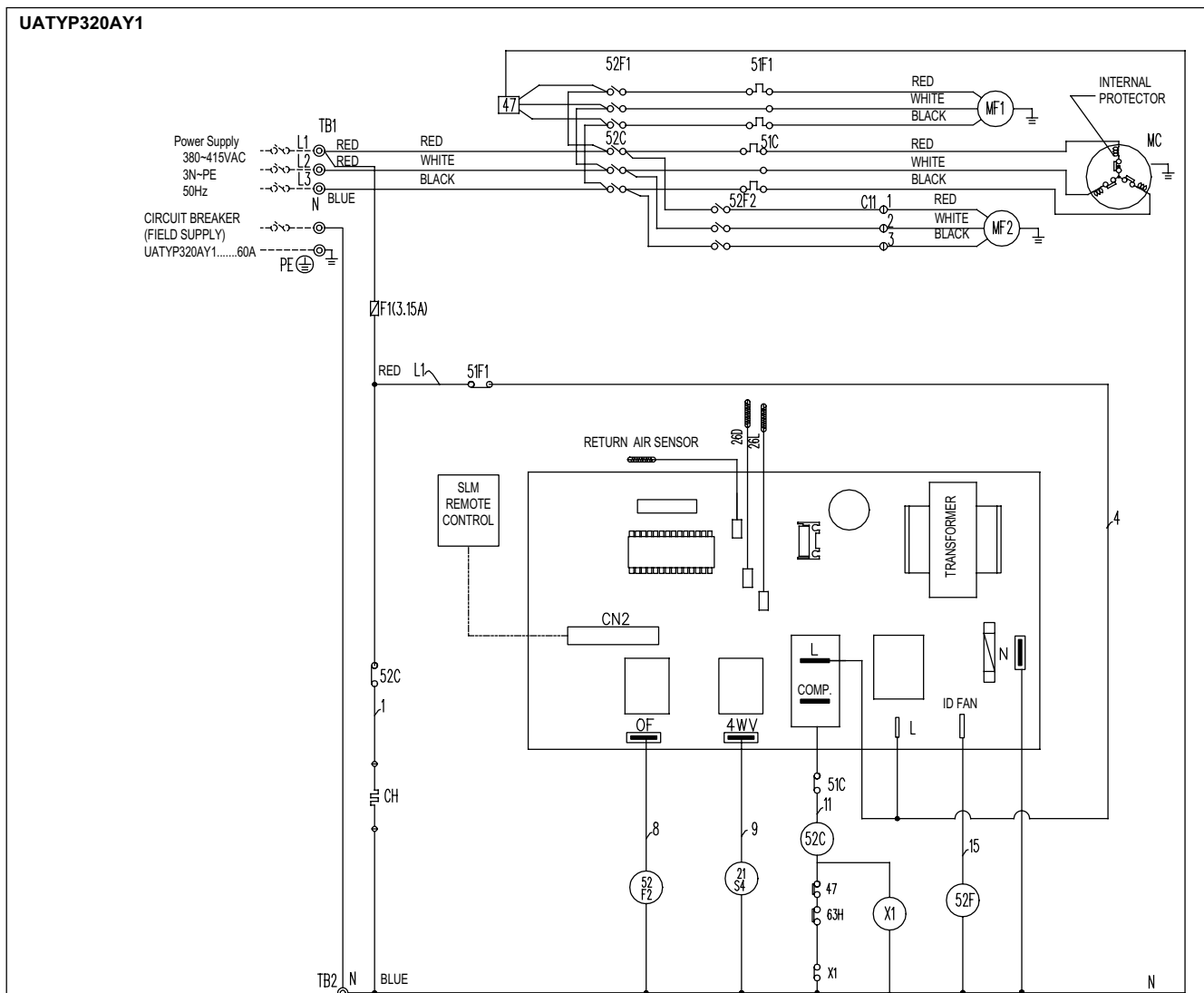

Arrangement

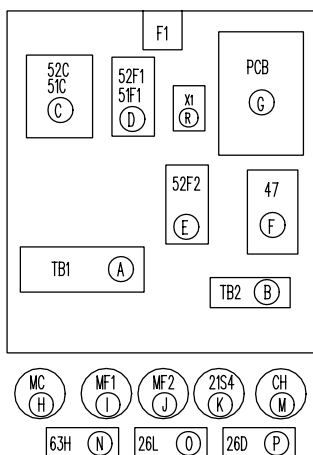

SYMBOL	NAME
MC	Compressor motor
MF1	Fan motor (indoor)
MF2	Fan motor (outdoor)
52C	Contactor (Compressor)
52F1	Contactor (fan I/D)
52F2	Contactor (fan O/D)
51C	Over current relay (comp)
51F1	Over current relay (fan I/D)
F1	Fuse (3.15A)
TB1,2	Terminal block
63H	High-pressure switch
CH	Crankcase heater
21S4	4-Way valve
26D	Sensor (defrost)
26L	Sensor (freeze protection)
PCB	Printed circuit board
47	Phase protector/Discharge thermostat
X1	Auxiliary relay (Self Hold)

Caution,

1. To protect each Fan motor and compressor from abnormal current, Over current relays <51C>, <51F> are installed. Therefore, do not change factory set value of Over current relays.

NOTES

- The dotted lines show field wiring.
- The figure in the parenthesis shows field supply parts.
- Color of earth is yellow and green twisting.

10 Wiring diagram

10 - 1 Wiring diagram

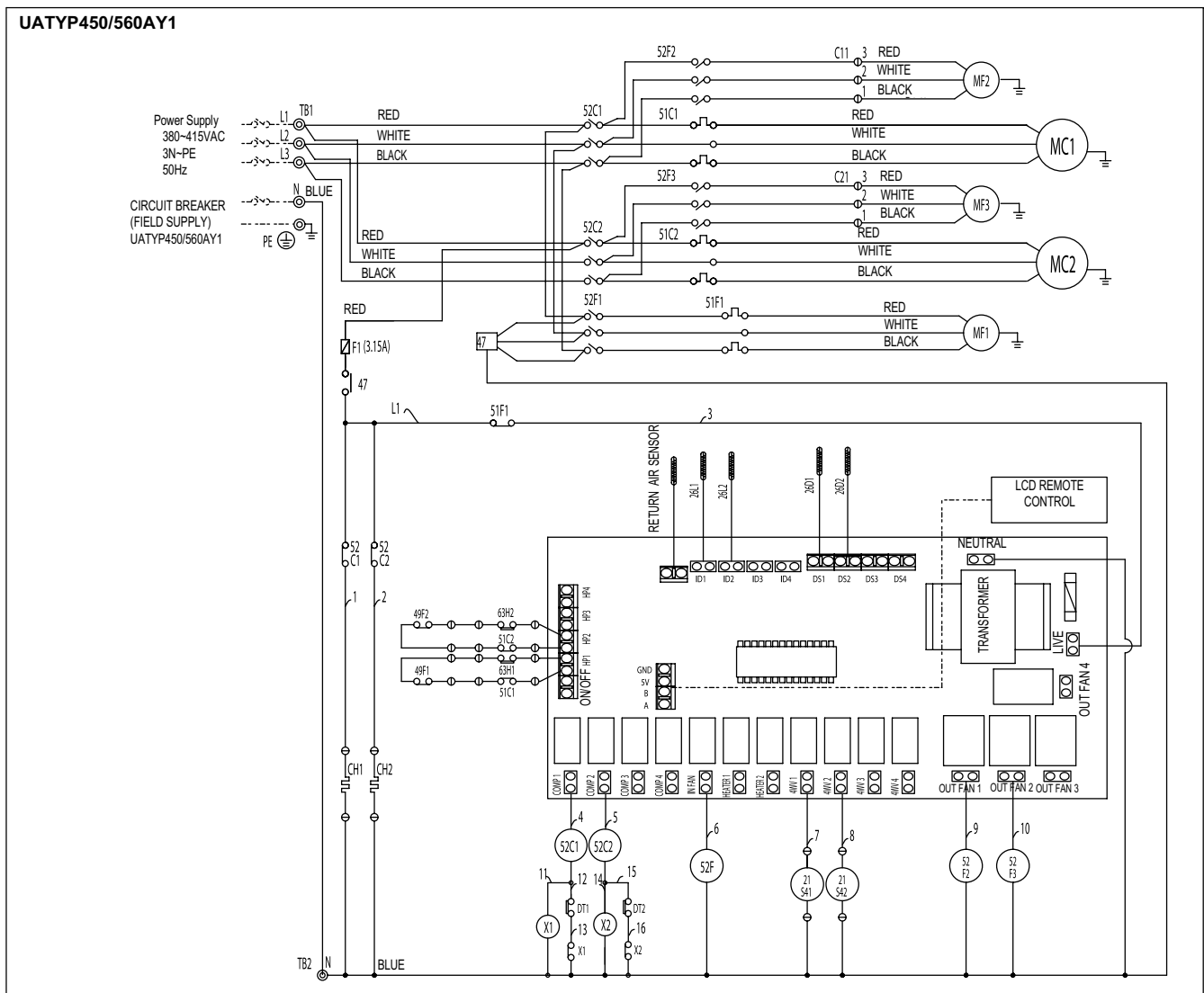

Arrangement

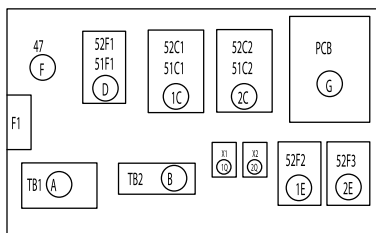

SYMBOL	NAME	SYMBOL	NAME
MC1,2	Compressor motor	63H1,2	High-pressure switch
MF1	Fan motor (indoor)	CH1,2	Crankcase heater
MF2,3	Fan motor (outdoor)	21S41,2	4-Way valve
52C1,2	Contactor (compressor)	26D1,2	Sensor (defrost)
52F1	Contactor (dan I/D)	26L1,2	Sensor (freeze protection)
52F2,3	Contactor (fan O/D)	PCB	Printed circuit board
TB1,2,3	Terminal block	47	Phase protector
F1	Fuse (3.15A)	DT1,2	Discharge thermostat
51C1,C2	Over current relay (COMP)	49F1,2	Internal protector (0d fan)
51F1	Over current relay (fan)	X1,2	Auxiliary relay (Self hold)

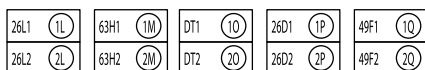
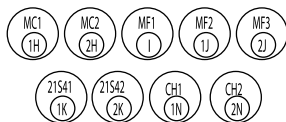

Caution,

1. To protect each Fan motor and compressor from abnormal current, Over current relays <51C>, <51F> are installed. Therefore, do not change factory set value of Over current relays.

NOTES

- The dotted lines show field wiring.
- The figure in the parenthesis shows field supply parts.
- Color of earth is yellow and green twisting.

10 Wiring diagram

10 - 1 Wiring diagram

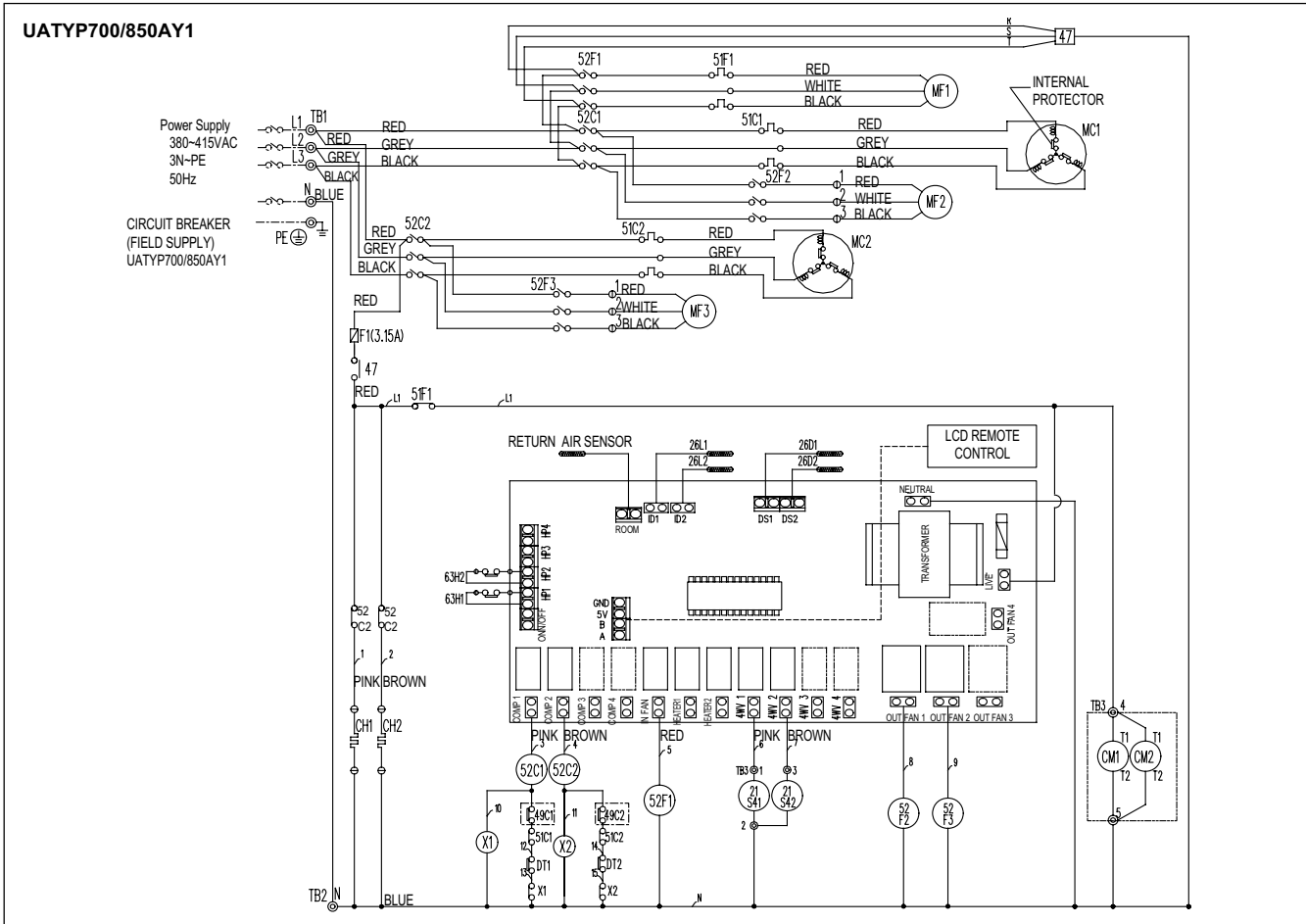

Arrangement

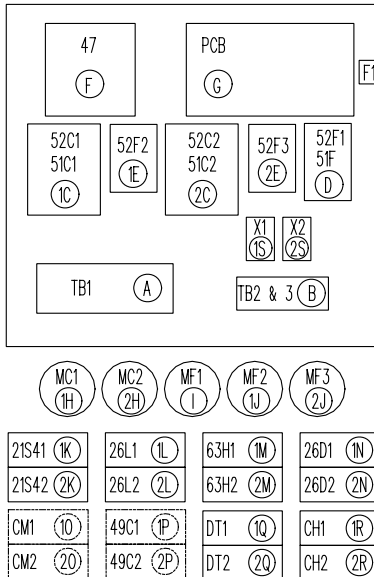

SYMBOL	NAME
MC1,2	Compressor motor
MF1	Fan motor (indoor)
MF2,3	Fan motor (outdoor)
52C1,2	Contactor (compressor)
52F1	Contactor (fan I/D)
52F2,3	Contactor (fan O/D)
51C1,C2	Overload protector (compressor)
TB1,2,3	Terminal block
F1	Fuse (3.15A)
51F	Overload protector (fan I/D)
63H1,2	High-pressure switch
CH1,2	Crankcase heater
21S41,2	4-Way valve
26D1,2	Sensor (defrost)
26L1,2	Sensor (freeze protection)
PCB	Printed circuit board
47	Phase protector
DT1,2	Discharge thermostat
X1,2	Auxiliary relay (self hold)
49C1,C2	Compressor internal overload
CM1,2	Compressor control module

*UATYP850AY1 only
*UATYP850AY1 only

Caution,

1. To protect each Fan motor and compressor from abnormal current, Overload protectors are installed. Therefore, do not change factory set value of the overload protector.

NOTES

- The dotted lines show field wiring:
- Color of earth is yellow and green twisting.
- Each wire is addressed.
- shows wiring for model UAT850AY1
In the case of UATP700AY1: no wire connection at TB3(4) and (5), &49C is replaced by single

10 Wiring diagram

10 - 1 Wiring diagram

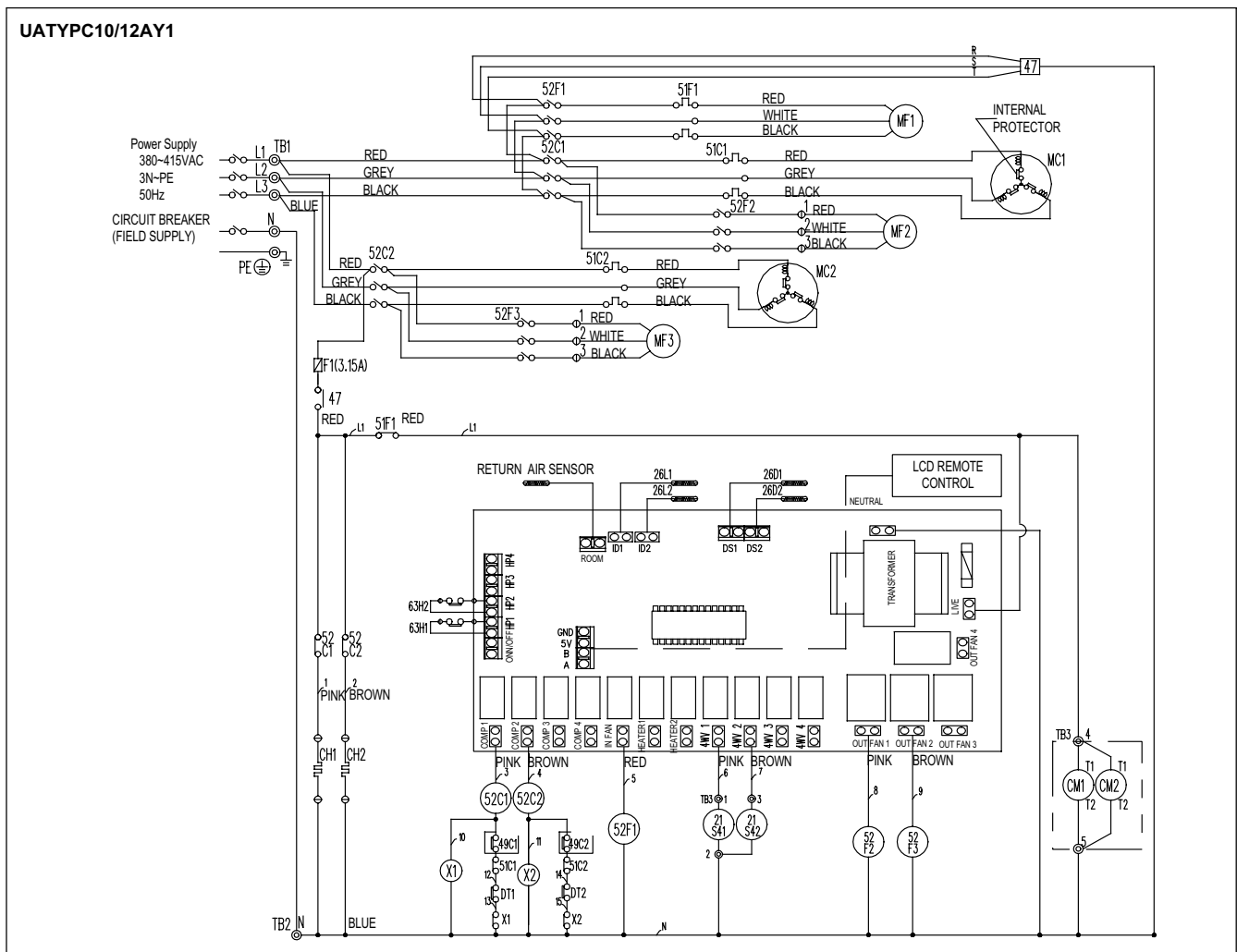

Arrangement

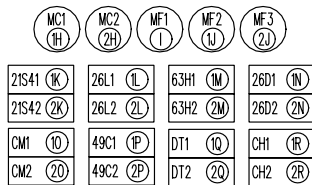
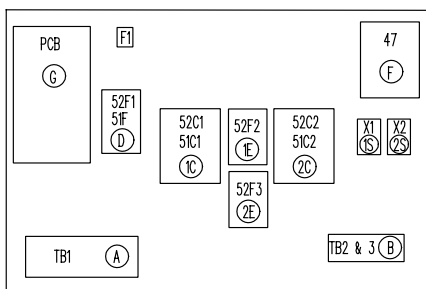

SYMBOL	NAME
MC1,2	Compressor motor
MF1	Fan motor (indoor)
MF2,3	Fan motor (outdoor)
52C1,2	Contacteur (compressor)
52F1	Contacteur (fan I/D)
52F2,3	Contacteur (fan O/D)
51C1,C2	Overload protector (compressor)
TB1,2,3	Terminal block
F1	Fuse (3.15A)
51F	Overload protector (fan I/D)
63H1,2	High-pressure switch
CH1,2	Crankcase heater
21S41,2	4-Way valve
26D1,2	Sensor (defrost)
26L1,2	Sensor (freeze protection)
PCB	Printed circuit board
47	Phase protector
DT1,2	Discharged thermostat
X1,2	Auxiliary relay (self hold)
49C1,C2	Compressor internal overload
CM1,2	Compressor control module

Caution,

1. To protect each Fan motor and compressor from abnormal current, Overload protectors are installed. Therefore, do not change factory set value of the overload protector.

NOTES

- 1 The dotted lines show field wiring.
- 2 Color of earth wire is yellow and green twisting.
- 3 Specification subject to change without notice.
- 4 Each wire is addressed.

11 Sound data

11 - 1 Sound pressure spectrum

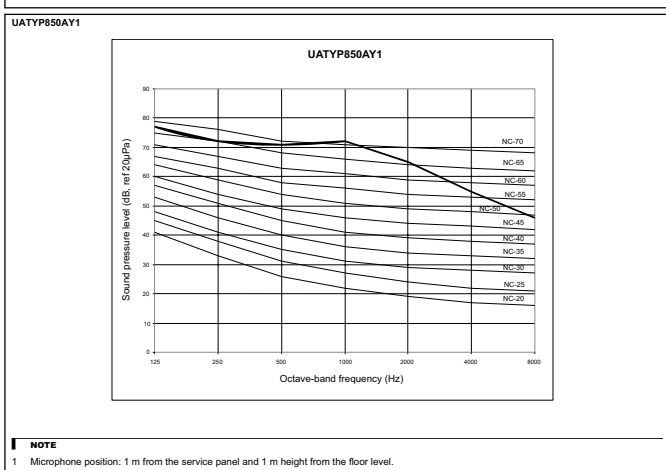
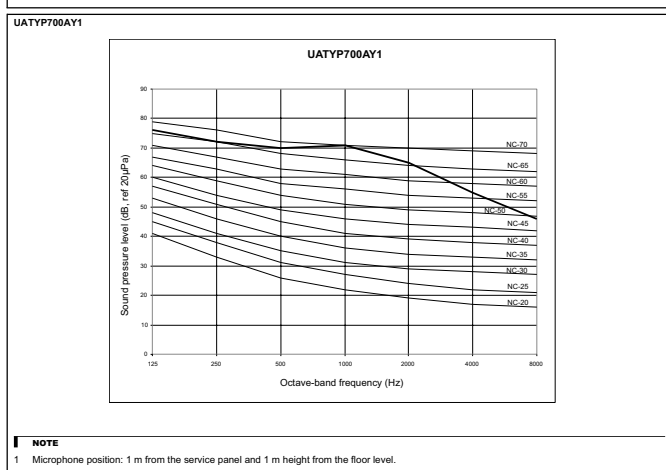
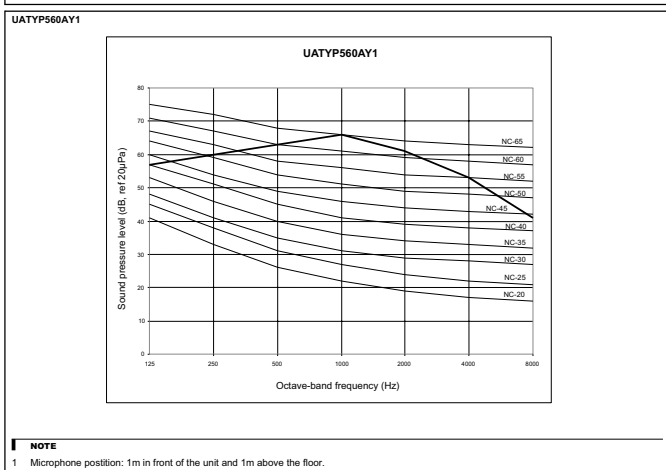
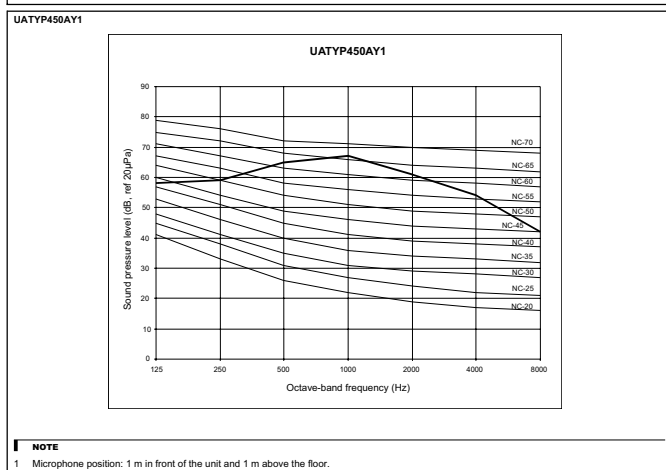
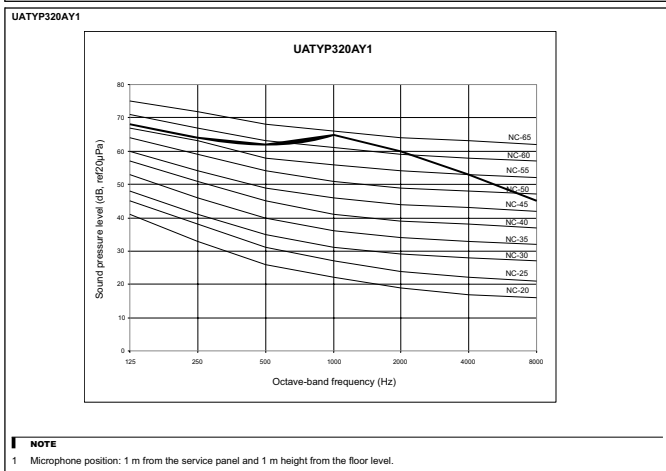
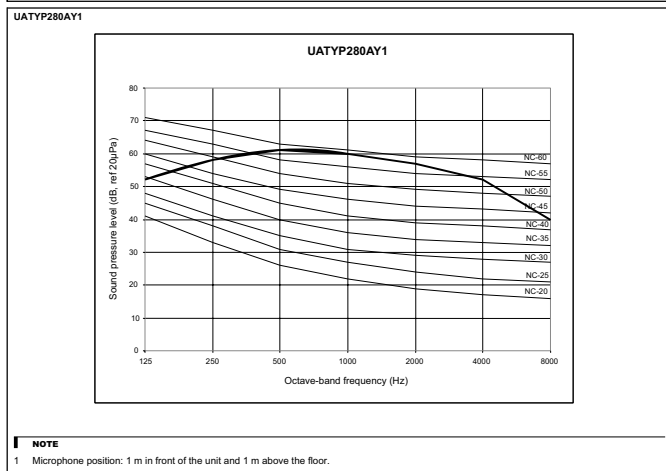
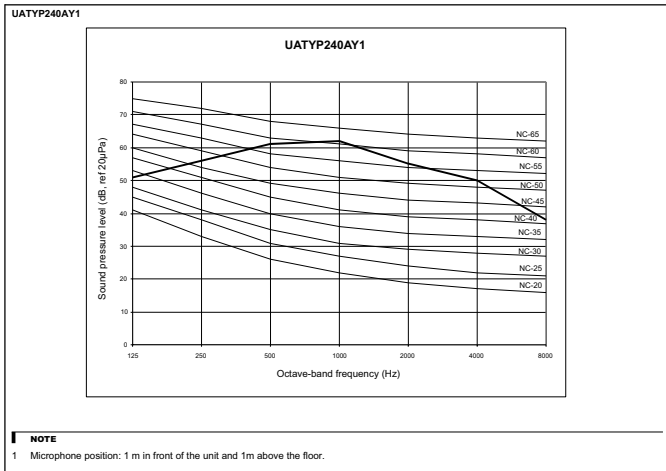
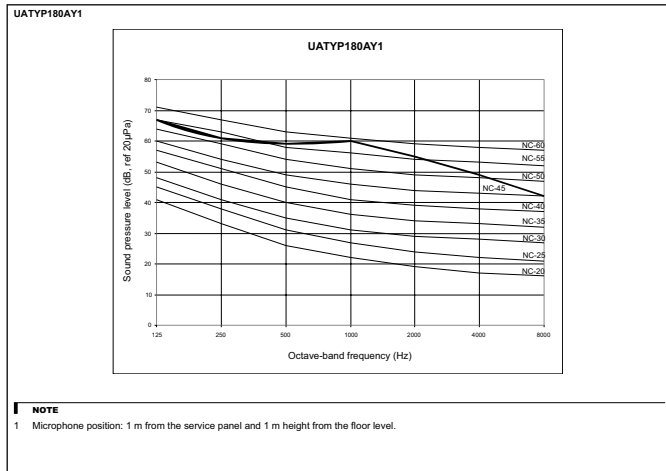

11 Sound data

11 - 1 Sound pressure spectrum

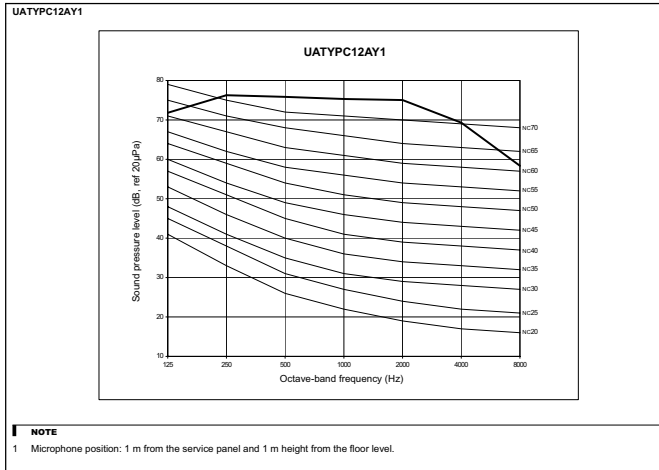
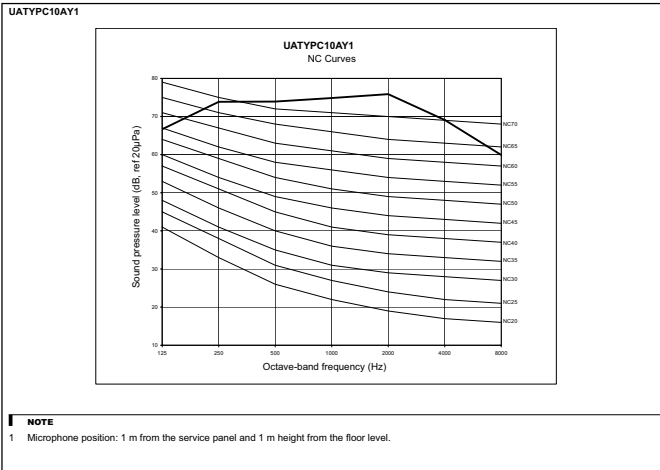

12 Fan characteristics

Selection Process

Drive Package

The following are the design requirements for UAT280AY1 unit:

Model: UAT280AY1

Supply Air Quantity = 3800 CFM
 External Static Pressure = 150 Pa

Step 1: From the blower curve (at 8000 CFM), Standard operating system, Internal Static pressure = 150 Pa

Step 2: Therefore at 3800 CFM and 150 Pa external static pressure, Total Static Pressure = 150 + 150 = 300 Pa

Step 3: From the blower curve, the design requirement calls for RPM about 1200 RPM.

From the table:
 Motor pulley = 114 mm
 Blower pulley = 152 mm
 Motor RPM = 1080

In order to obtain 1200 RPM, we calculate the new blower pulley as: (while maintaining the motor pulley)
 $Db = 114 \times (1080/1200) = 102.6$ mm

Let us take close approximation of 100 mm diameter pulley size

Recheck, with Db = 100mm
 Blower pulley = 1080 x (114/100) = 1231.2 RPM

We thus need to change the blower pulley from 152 mm to 100 mm in order to obtain the higher operating static pressure.

Step 4: When the pulley is changed, the V-belt length must be rechecked. We have for horizontal air throw configuration:
 $V\text{-belt length, } L = 2C + 1.57(Db + Dm) = (2 \times 184) + 1.57(114 + 100) = 703.98$

We thus can use a belt with a length of 704 mm.

where, C = distance between the centres of the two pulleys
 Db = diameter of blower pulley
 Dm = diameter of motor pulley

Step 5: From the blower curve, we can also notice that the motor power input has maintained within the current operating range of the standard unit's motor.

Summary:
 i) Fan motor kW = 1.5
 ii) Blower pulley diameter = 100 mm
 iii) V-belt size = 704

The following table summarizes the pulley data, motor size used for the UATP-series, as manufactured:

Model	Blower pulley, Db			Motor Pulley, Dm		
	Type	Diameter (mm)	Bore (mm)	Type	Diameter (mm)	Bore (mm)
UATYP180A1	B1	152	20	B1	102	19
UATYP240A1	B1	152	20	B1	102	24
UATYP280A1	B1	152	20	B1	114	24
UATYP320A1	B1	140	20	B1	114	24
UATYP450A1	B2	254	28	B2	127	28
UATYP550A1	B2	254	28	B2	152	28
UATYP700A1	SPZ 2	224	25	SPZ 2	125	38
UATYP850A1	SPZ 2	224	25	SPZ 2	140	38
UATYP10AY1	SPA	280	40	SPA	124	38
UATYP12AY1	SPA	250	40	SPA	118	38

Model	V-belt length L (mm)	Pulley Centre Distance, C (mm)		Motor kW	Motor RPM
		Diameter (mm)	Minimum / Maximum		
UATYP180A1	762	180	126 / 224	0.75	960
UATYP240A1	762	180	126 / 224	1.1	960
UATYP280A1	762	184	126 / 224	1.5	1080
UATYP320A1	762	180	126 / 224	1.5	1100
UATYP450A1	1067	225	190 / 306	2.2	730
UATYP550A1	1092	221	190 / 306	3.7	850
UATYP700A1	1662	558	558 / 572	5.5	840
UATYP850A1	1700	565	558 / 572	7.5	880
UATYP10AY1	2132	748	730 / 763	7.5	1440
UATYP12AY1	2020	736	730 / 763	7.5	1440

PULLEY OUTSIDE DIMENSIONS ARE SHOWN BELOW: (UNIT : MM)

(1) Shape Of Belt Groove

1.1

Shape of V-belt	Nominal Dia. ØPC	a (°)	W	Lo	K	Ko	e	f	f ₁	f ₂	f ₃	V-belt thickness (Reference)
B	Over 125 Under 180	34	15.86	12.5	5.5	9.5	19.0	12.5	0.2-0.5	0.5-1.0	1-2	11
	Over 180 Under 200	36	16.07									
	Over 200	38	16.29									

Sectional plan of V-belt

B-type

1.2 Taper lock type UATYP700/850AY1

Section	Sheave dia. d _s	Groove angle β	W _d	b _{min}	h _{min}	e	f
SPZ	71-80 >80	34° 38°	8.5	2.0	9.0	12±0.3	8±1

Sectional plan of V-belt

(2) Shape Of Motor Pulley Boss (unit:mm)

MOTOR CAPACITY (kW)	A	B	C
1.1, 1.5	Ø24 +0.028 -0.007	27 +0.128 -0.007	8 +0.018 -0.018
2.2, 3.7	Ø28 +0.028 -0.007	31 +0.128 -0.007	8 +0.028 -0.013
5.5, 7.5	Ø38 +0.028 -0.007	41 +0.128 -0.009	10 +0.028 -0.013

Fan Performance Curve UATYP180AY1

12 Fan characteristics

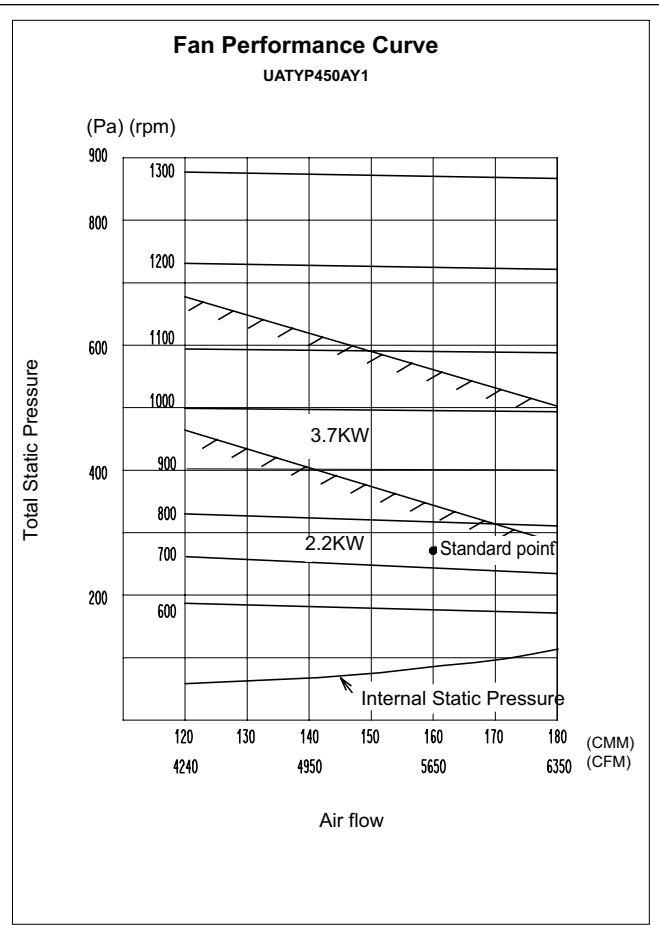
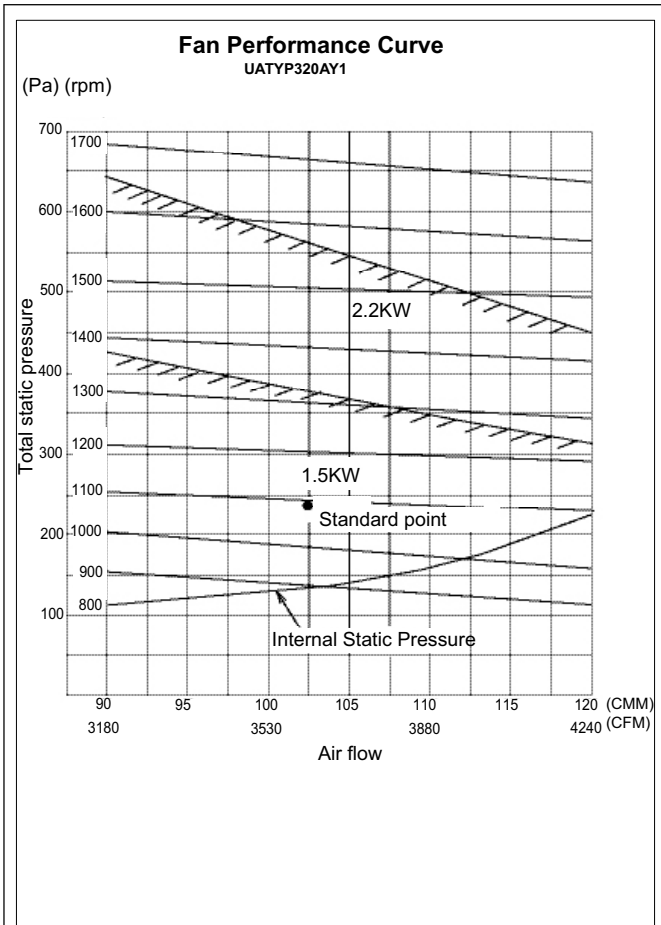
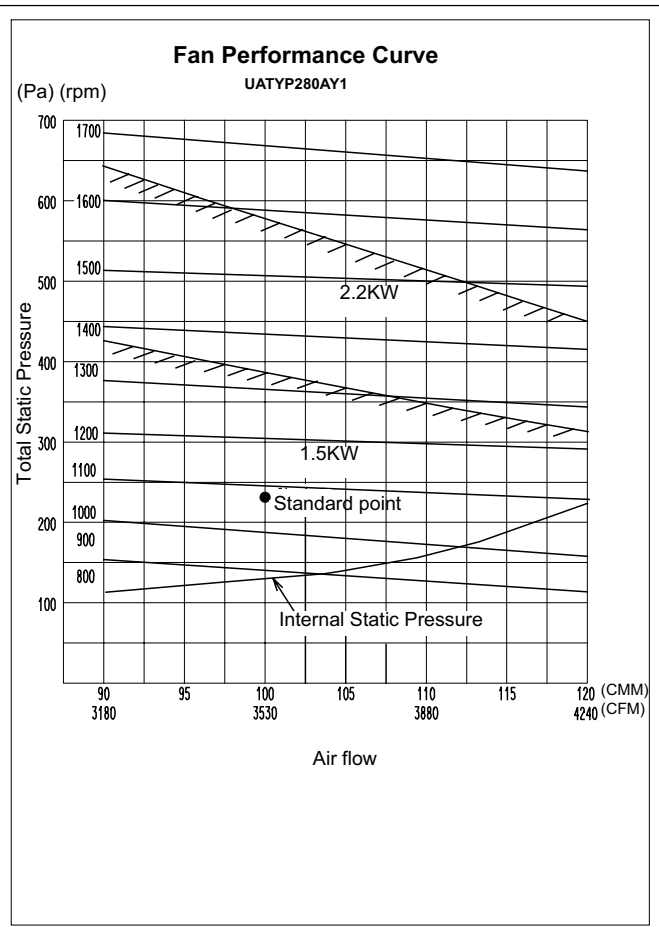
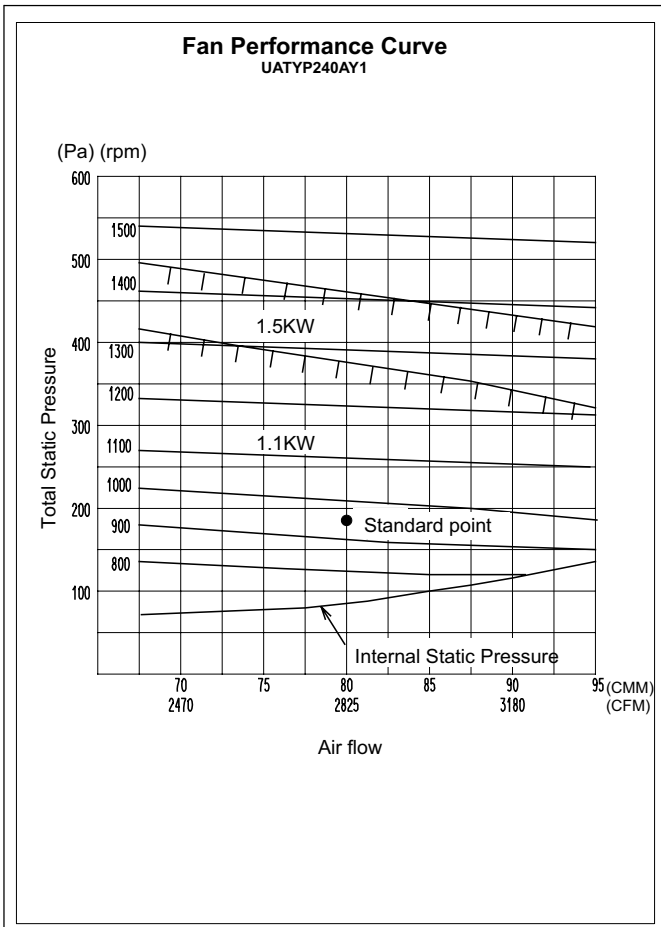

12 Fan characteristics

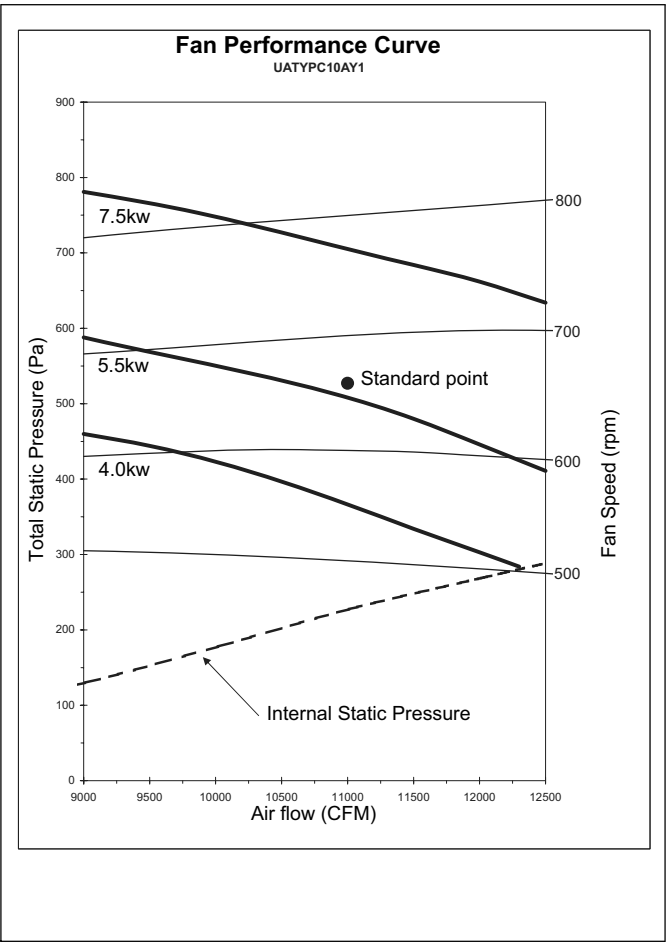
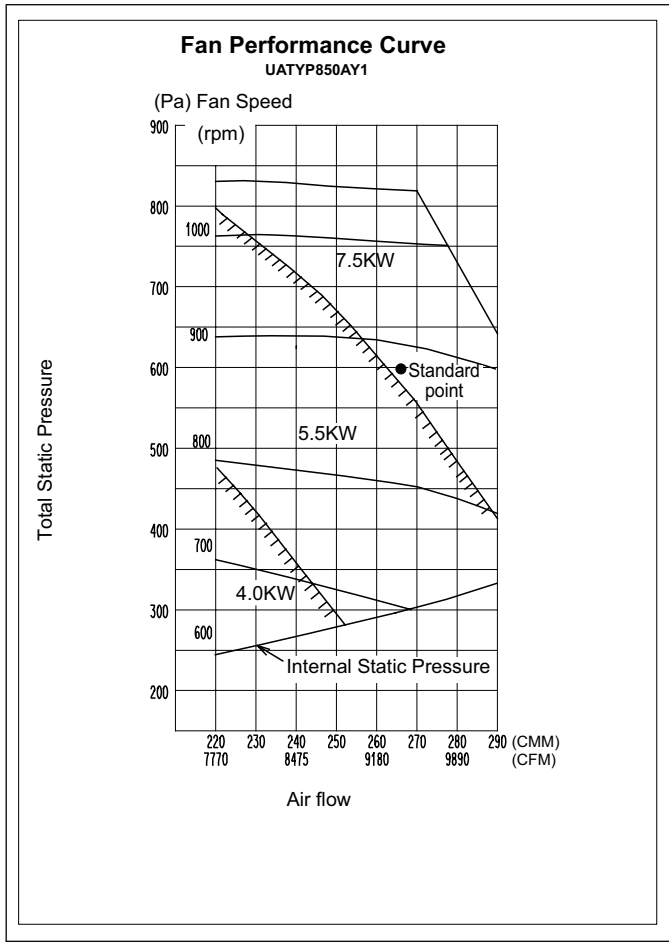
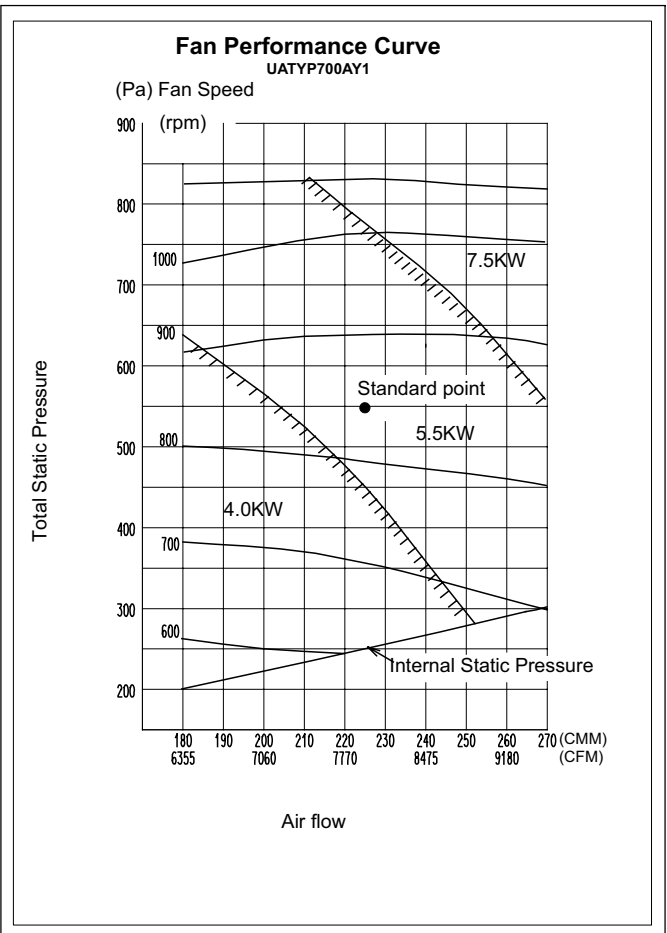
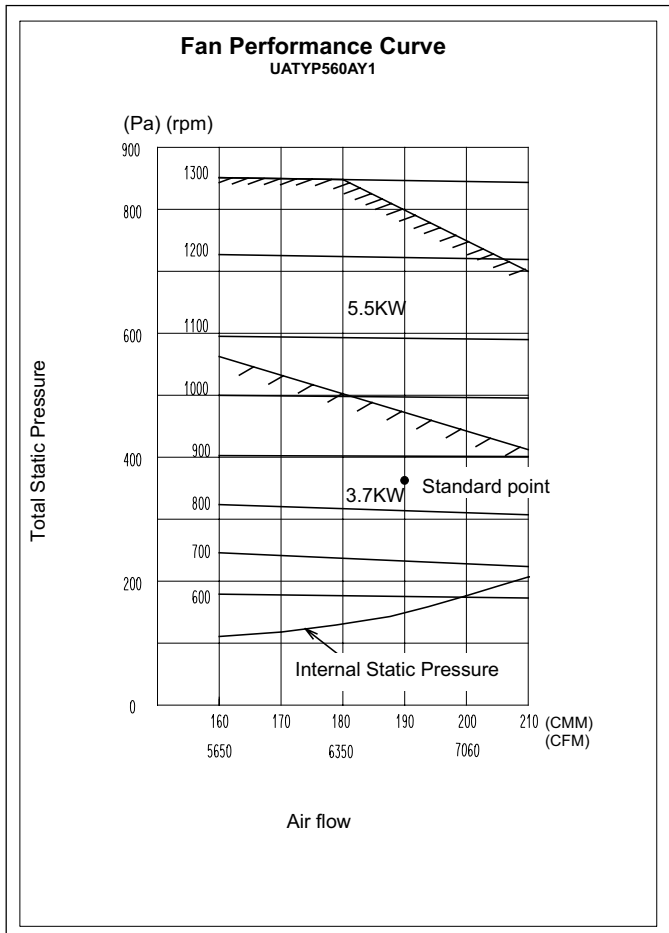

12 Fan characteristics

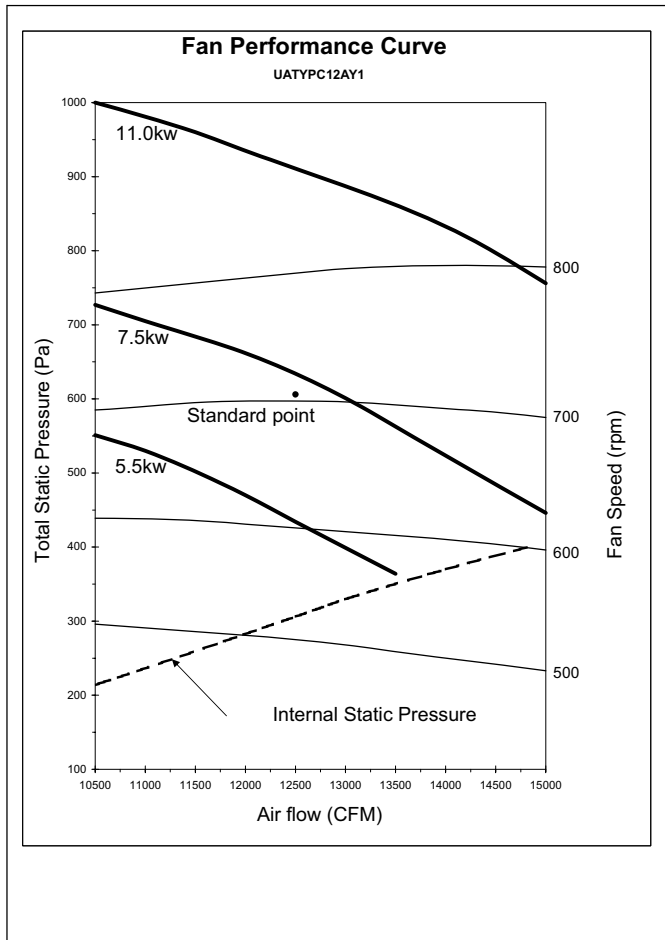

13 Operation range

UATYP-AY1

Cooling

Cooling Only Unit & Cooling Mode For Heat Pump Unit

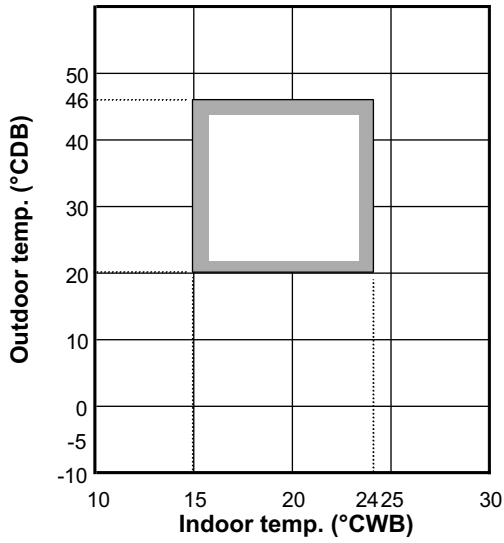

Heating

Heat Pump Unit Only

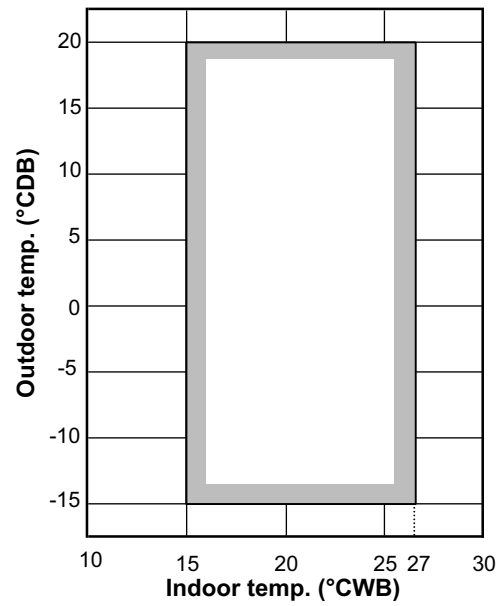

NOTES

- The use of your air conditioner outside the range of working temperature and humidity can result in serious failure.

Rooftops



Daikin's unique position as a manufacturer of air conditioning equipment, compressors and refrigerants has led to its close involvement in environmental issues. For several years Daikin has had the intension to become a leader in the provision of products that have limited impact on the environment. This challenge demands the eco design and development of a wide range of products and an energy management system, resulting in energy conservation and a reduction of waste.



Daikin Europe N.V. is approved by LRQA for its Quality Management System in accordance with the ISO9001 standard. ISO9001 pertains to quality assurance regarding design, development, manufacturing as well as to services related to the product.



ISO14001 assures an effective environmental management system in order to help protect human health and the environment from the potential impact of our activities, products and services and to assist in maintaining and improving the quality of the environment.



Daikin units comply with the European regulations that guarantee the safety of the product.

The present publication is drawn up by way of information only and does not constitute an offer binding upon Daikin Europe N.V.. Daikin Europe N.V. has compiled the content of this publication to the best of its knowledge. No express or implied warranty is given for the completeness, accuracy, reliability or fitness for particular purpose of its content and the products and services presented therein. Specifications are subject to change without prior notice. Daikin Europe N.V. explicitly rejects any liability for any direct or indirect damage, in the broadest sense, arising from or related to the use and/or interpretation of this publication. All content is copyrighted by Daikin Europe N.V..

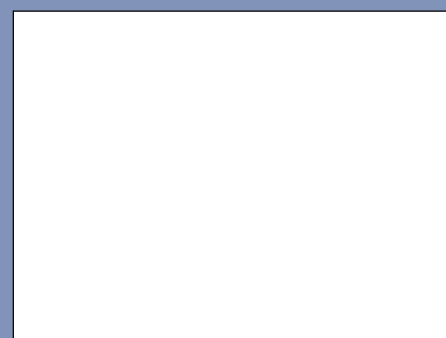

DAIKIN EUROPE N.V.

Naamloze Vennootschap
Zandvoordestraat 300
B-8400 Oostende, Belgium
www.daikin.eu
BE 0412 120 336
RPR Oostende



EEDEN10-106 • 08/2010 • Copyright Daikin
Printed in Belgium by Lannoo (www.lannooprint.be), a company whose concern for the environment is set in the EMAS and ISO 14001 systems.
Responsible Editor: Daikin Europe N.V., Zandvoordestraat 300, B- 8400 Oostende