

Chillers

Commercial and Technical Data

Air cooled free cooling chiller

- » **Integrated free cooling**
- » **Cooling as good as free from 3°C or lower**
- » **Substantial energy savings during cold season**
- » **Multiple sound level versions**
- » **Wide capacity range (600 kW - 1,565 kW)**



ECDEN12-435

EWAD-CF
600~1,565 kW

R-134a



About Daikin

Daikin has a worldwide reputation based on over 85 years' experience in the successful manufacture of high quality air conditioning equipment for industrial, commercial and residential use. Daikin's much envied quality quite simply stems from the close attention paid to design, production and testing, as well as aftersales support. To this end, every component is carefully selected and rigorously tested to verify its contribution to product quality and reliability.

Reduced energy consumption and CO₂ emissions thanks to our new free cooling series

The 'EWAD~CF' series answers the growing requirements for energy saving - as conceived to reduce operating costs of the chiller system - by using low external air temperatures to assist in chilling water, which is then used in data centres or industrial processes.

Using a 'free cooling' chiller the consumption of energy by the cooling units is significantly reduced during the colder seasons. In fact, when outside temperatures are cold enough – 3°C or lower depending on model – the chillers compressors are fully shut down and cooling is practically for free. This leads to dramatically reduced load on the compressors and substantial savings in annual operating costs can be achieved.

Moreover, cutting the compressor usage is also contributing to extend the chillers' operating life, minimising even further the overall cost of an installation.

With the introduction of the new 'free cooling' range to the EWAD-C chiller series, we deliver on our commitment to supply superior solutions, suitable for diverse applications, requiring the highest levels of energy efficiency, savings and comfort.



Table of Contents

THE AIR COOLED FREE COOLING CHILLER FEATURES	4
TECHNICAL DATA	5
1 EWAD-CFXS	7
2 EWAD-CFXL	33
3 EWAD-CFXR	59



The air cooled free cooling chiller features

Application flexibility

The 'EWAD~CF' series is available in multiple sound level versions, including a variety of capacity sizes (from 600kW up to 1,565kW), making it an ideal match for flexible solutions in a wide range of building applications.

Extensive option list

The base model includes several standard factory mounted options, such as: inverter fans, electronic expansion valve, wye delta starter, phase monitor, hour run meter, etc. Moreover, the new range features an extensive option list, including: rapid restart, brine version, soft starter, different coil and pump types, etc.

Lowered carbon footprint

Because our 'free cooling' chillers use the colder outside air to precool the water used, they use significantly less input energy thus reducing the global environmental impact of the system and helping deliver the EU's energy targets, while at the same time improving your company's green profile.

Increased energy efficiency

Whenever the climatic conditions allow it, the free cooling coil enables to cool the water using the external air, thus reducing the load on the compressors. In this way, when outside temperatures are decreasing the power absorbed decreases, until only the fans are used (from 3°C or lower depending on model).

Meets any acoustic need

Maximum flexibility in offering a range with 3 different sound level versions - thanks to the combination of acoustic solutions, such as low fan rotation speed and a soundproof compressor casing - in order to meet any installation need.

Superior control logic

The new MicroTech III controller provides an easy to use control. The control logic is designed to provide maximum efficiency, to continue operation in unusual operating conditions and to provide a history of unit operation. One of the greatest benefits is the easy interface with LonWorks, BACnet, Ethernet TCP/IP or Modbus communications.

EWAD-CF

I	Air-cooled chiller, high efficiency		
	EWAD-CFXS	7	1
	EWAD-CFXL	33	2
	EWAD-CFXR.....	59	3

TABLE OF CONTENTS

EWAD-CFXS

1	Features	8
2	Specifications	9
	Technical Specifications	9
	Electrical Specifications	10
3	Features and advantages	11
	Features and Advantages	11
4	General Characteristics	13
	General characteristics	13
5	Nomenclature	17
	Nomenclature	17
6	Capacity tables	18
	Cooling Capacity Tables	18
7	Dimensional drawings	22
	Dimensional Drawings	22
8	Sound data	23
	Sound Level Data	23
9	Installation	24
	Installation Method	24
	Water Charge, Flow and Quality	26
10	Operation range	28
	Operation Range	28
11	Specification text	29
	Specification Text	29

1 Features

- High efficiency, standard sound levels
- Free cooling chiller
- Greater energy savings and reduced CO₂ emissions during cold season
- Wide capacity range: 11 sizes between 600 and 1.565 kW
- Wide operating range
- MicroTech III controller



2 Specifications

2-1 Technical Specifications				EWAD 640CFXS	EWAD 770CFXS	EWAD 850CFXS	EWAD 900CFXS	EWAD C10CFXS	EWAD C11CFXS	EWAD C12CFXS	EWAD C13CFXS	EWAD C14CFXS	EWAD C15CFXS	EWAD C16CFXS	
Cooling capacity	Nom.	kW		640 (1)/ 295 (2)	772 (1)/ 365 (2)	852 (1)/ 413 (2)	902 (1)/ 434 (2)	1,027 (1)/ 502 (2)	1,089 (1)/ 524 (2)	1,269 (1)/ 594 (2)	1,349 (1)/ 652 (2)	1,435 (1)/ 663 (2)	1,493 (1)/ 659 (2)	1,555 (1)/ 722 (2)	
Capacity control	Method	Stepless													
	Minimum capacity	%	12.5												
Power input	Cooling	Nom.	kW	257 (1)/ 74.3 (2)	272 (1)/ 87.9 (2)	293 (1)/ 90.7 (2)	324 (1)/ 99.8 (2)	360 (1)/ 109 (2)	399 (1)/ 118 (2)	397 (1)/ 131 (2)	439 (1)/ 143 (2)	454 (1)/ 152 (2)	492 (1)/ 160 (2)	530 (1)/ 170 (2)	
EER				2.49 (1)/ 8.62 (2)	2.84 (1)/ 8.78 (2)	2.90 (1)/ 9.4 (2)	2.78 (1)/ 9.04 (2)	2.85 (1)/ 9.43 (2)	2.73 (1)/ 9.19 (2)	3.19 (1)/ 9.67 (2)	3.08 (1)/ 9.45 (2)	3.16 (1)/ 9.42 (2)	3.04 (1)/ 9.33 (2)	2.93 (1)/ 9.16 (2)	
ESEER				3.44	3.52	3.78	3.50	3.74	3.54	3.88	3.78	4.01	3.95	3.85	
IPLV				3.87	4.03	4.07	4.05	4.00	3.93	4.36	4.25	4.36	4.35	4.24	
Casing	Colour	Ivory white													
	Material	Galvanized and painted steel sheet													
Dimensions	Unit	Height	mm	2,565										2,565	
		Width	mm	2,480										2,480	
		Depth	mm	6,185	7,085	7,985	8,885	10,685				10,685			
Weight	Unit	kg	7,760	8,340	8,900	10,160	10,420	11,900	12,540	12,620	12,670				
	Operation weight	kg	8,040	8,580	9,140	10,560	10,820	12,290	13,530	13,610	13,660				
Water heat exchanger	Type	Single pass shell & tube													
	Water volume	l	266	251	243	403	386	979							
	Nominal water flow	Cooling	l/s	27.8	33.5	37.0	39.2	44.6	47.3	55.1	58.6	62.4	64.9	67.6	
	Nominal water pressure drop	Cooling	Heat exchanger	kPa	85 / 128 (2)	105 / 172 (2)	90 / 178 (2)	101 / 198 (2)	111 / 245 (2)	124 / 272 (2)	98 / 232 (2)	110 / 259 (2)	139 / 305 (2)	150 / 328 (2)	162 / 354 (2)
	Insulation material	Closed cell													
Air heat exchanger	Type	High efficiency fin and tube type with integral subcooler													
Fan	Quantity	10	12	14	16	20									
	Type	Direct propeller													
	Diameter	mm	800												
	Air flow rate	Nom.	l/s	50,367	60,440	70,513	80,587	95,253							
	Speed	rpm	920												
Fan motor	Drive	Inverter													
	Input	Cooling	W	5,200	6,300	6,800	7,300	8,400	9,200	14,100	18,100	10,800	18,100	12,700	
Sound power level	Cooling	Nom.	dBA	99.5	100.2	100.5	101.4	101.9	102.4	102.5					
Sound pressure level	Cooling	Nom.	dBA	79.0 (1)	79.7 (1)			80.2 (1)	80.7 (1)	80.3 (1)	80.4 (1)				
Compressor	Type	Asymm single screw													
	Quantity	2													
	Oil	Charged volume	l	38			44	50							
Operation range	Water side	Cooling	Min.	°CDB					-8						
			Max.	°CDB					15						
	Air side	Cooling	Min.	°CDB					-20						
			Max.	°CDB					45						
Refrigerant	Type	R-134a													
	Charge	kg	128	146	162	182	214	225	248						
	Circuits	Quantity	2												
Piping connections	Evaporator water inlet/outlet (OD)	DN150PN16(168.3mm)				DN200PN16(219.1mm)				DN250PN16(273mm)					
Mechanical capacity	kW	345 (2)	407 (2)	439 (2)	468 (2)	524 (2)	565 (2)	675 (2)	697 (2)	772 (2)	834 (2)				
Air temperature for free cooling 100%	°C	-0.8	-0.1	1.2	0.4	0.9	0.1	2.9	2.1	1.3	0.7	0.1			

1
2

2 Specifications

2-2 Electrical Specifications				EWAD 640CFXS	EWAD 770CFXS	EWAD 850CFXS	EWAD 900CFXS	EWAD C10CFXS	EWAD C11CFXS	EWAD C12CFXS	EWAD C13CFXS	EWAD C14CFXS	EWAD C15CFXS	EWAD C16CFXS	
Compressor	Phase			3~											
	Voltage			400											
	Voltage range	Min.	%	-10											
		Max.	%	10											
	Maximum running current			A	218	231	274	333	398	451					
	Starting method			Wye-delta											
Compressor 2	Maximum running current			A	218	231	274	333	398	451					
Power supply	Phase			3~											
	Frequency			Hz											
	Voltage			V											
	Voltage range	Min.	%	-10											
		Max.	%	10											
	Unit	Maximum starting current			A	605	619	658	924	971	1,030	1,073	1,086		
Nominal running current (RLA)		Cooling	A	404	430	467	515	568	628	636	701	720	773	825	
			A	476	510	561	605	672	731	811	875	929	982		
Max unit current for wires sizing			A	520	556	612	660	733	797	884	955	1,013	1,072		
Fans	Nominal running current (RLA)			A	40	48	56	64	80						

Notes

- (1) Cooling: evaporator 16/10°C, ambient 35°C, unit at full load operation; standard: ISO 3744
- (2) Data is calculated at ambient air temperature 5°C, inlet water temperature 16°C.
- (3) Fluid: water + ethylene glycol 30%
- (4) Allowed voltage tolerance ± 10%. Voltage unbalance between phases must be within ± 3%.
- (5) Maximum starting current: starting current of biggest compressor + 75 % of maximum current of the other compressor + fans current for the circuit at 75 %
- (6) Nominal current in cooling mode: entering evaporator water temp. 12°C; leaving evaporator water temp. 7°C; ambient air temp. 35°C. Compressor + fans current.
- (7) Maximum running current is based on max compressor absorbed current in its envelope and max fans absorbed current
- (8) Maximum unit current for wires sizing is based on minimum allowed voltage.
- (9) Maximum current for wires sizing: (compressors full load ampere + fans current) x 1.1

3 Features and advantages

3 - 1 Features and Advantages

Low operating cost and extended operating life

This chiller range is the result of careful design, aimed to optimize the energy efficiency of the chillers, with the objective of bringing down operating costs and improving installation profitability, effectiveness and economical management.

The chillers feature a high efficiency single screw compressor design, large condenser coil surface area for maximum heat transfer and low discharge pressure, advanced technology condenser fans and a 'shell&tube' evaporator with low refrigerant pressure drops.

The free cooling chillers make use of an additional free cooling section to cool the building water loop directly with the outside ambient air, thus reducing the load on the compressors and considerably decreasing operating costs during the cold season. Free cooling takes advantage of the temperature difference between the outside air and the return water to cool the water before returning it at a lower temperature to be chilled. And when outside temperatures are cold enough the chillers compressors are fully shut down and cooling is practically free. Moreover, cutting compressor usage also extends the chiller's operating life, further minimizing the overall cost of an installation.

Low operating sound levels

Very low sound levels both at full load and part load conditions are achieved by the latest compressor design and by a unique new fan that moves large volume of air at exceptionally low sound levels and by the virtually vibration-free operation.

Outstanding reliability

The chillers have two truly independent refrigerant circuits, in order to assure maximum safety for any maintenance, whether planned or not. They are equipped with a rugged compressor design with advanced composite compressor gaterotors material, a proactive control logic and are full factory-run-tested to optimized trouble-free operation.

Infinite capacity control

Cooling capacity control is infinitely variable by means of a single screw asymmetric compressor controlled by microprocessor system. Each unit has infinitely variable capacity control from 100% down to 12.5%. This modulation allows the compressor capacity to exactly match the building cooling load without any leaving evaporator water temperature fluctuation. This chilled water temperature fluctuation is avoided with a stepless control.

With a compressor load step control in fact, the compressor capacity, at partial loads, will be too high or too low compared to the building cooling load. The result is an increase in chiller energy costs, particularly at the part-load conditions at which the chiller operates most of the time.

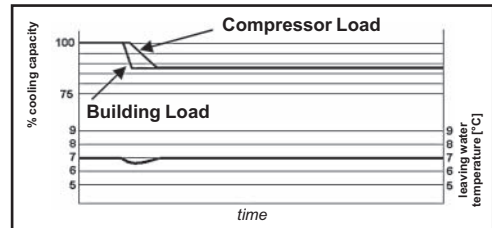

ELWT fluctuation with steps capacity control

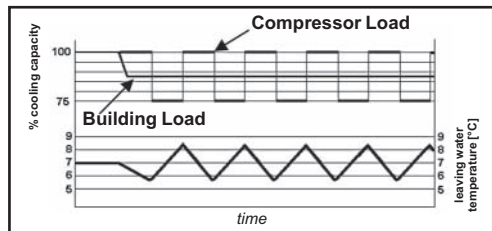

ELWT fluctuation with steps capacity control (4 steps)

Units with stepless regulation offer benefits that the units with step regulation are unable to match. The ability to follow the system energy demand at any time and the possibility to provide steady outlet water temperature without deviations from the set-point, are the two points that allow you to understand how the optimum operating conditions of a system can be met through the use of a unit with stepless regulation.

3 Features and advantages

3 - 1 Features and Advantages

Superior control logic

The new MicroTech III controller provides an easy to use control environment. The control logic is designed to provide maximum efficiency, to continue operation in unusual operating conditions and to provide a history of unit operation. One of the greatest benefits is the easy interface with LonWorks, Bacnet, Ethernet TCP/IP or Modbus communications.

Code requirements – Safety and observant of laws/directives

The range is designed and manufactured in accordance with applicable selections of the following:

Construction of pressure vessel	97/23/EC (PED)
Machinery Directive	2006/42/EC
Low Voltage	2006/95/EC
Electromagnetic Compatibility	2004/108/EC
Electrical & Safety codes	EN 60204–1 / EN 60335-2-40
Manufacturing Quality Stds	UNI – EN ISO 9001:2004

Certifications

All units manufactured by Daikin are CE marked, complying with European directives in force, concerning manufacturing and safety. On request units can be produced complying with laws in force in non European countries (ASME, GOST, etc.), and for other applications, such as naval (RINA, etc.).

Versions

The range is available is available in three versions:

X: High efficiency

11 sizes to cover a range from 640 up to 1555 kW with an EER up to 3.19 and an ESEER up to 4.01 (data referred to Standard Noise)

The EER (Energy Efficiency Ratio) is the ratio of the Cooling Capacity to the Power Input of the unit. The Power Input includes: the power input for operation of the compressor, the power input of all control and safety devices, the power input for fans.

The ESEER (European Seasonal Energy Efficiency Ratio) is a weighed formula enabling to take into account the variation of EER with the load rate and the variation of air inlet condenser temperature.

$$ESEER = A \times EER_{100\%} + B \times EER_{75\%} + C \times EER_{50\%} + D \times EER_{25\%}$$

	A	B	C	D
Coefficient	0.03 (3%)	0.33 (33%)	0.41 (41%)	0.23 (23%)
Air inlet condenser temperature	35°C	30°C	25°C	20°C

Sound configurations

The range is available is available in three versions:

S: Standard Sound

Condenser fan rotating at 920 rpm, rubber antivibration under compressor

L: Low Sound

Condenser fan rotating at 920 rpm, rubber antivibration under compressor, compressor sound enclosure.

X: Reduced Sound

Condenser fan rotating at 715 rpm, rubber antivibration under compressor, compressor sound enclosure.

4 General Characteristics

4 - 1 General characteristics

Cabinet and structure

The cabinet is made of galvanized steel sheet and painted to provide a high resistance to corrosion. Colour Ivory White (Munsell code 5Y7.5/1) (\pm RAL7044). The base frame has an eye-hook to lift the unit with ropes for an easy installation. The weight is uniformly distributed along the profiles of the base and this facilitates the arrangement of the unit.

Compressor (Asymmetric Single Screw)

The compressor is semi-hermetic, single-screw type with gate-rotor made with the latest high-strength fibre reinforced star material. The compressor has an asymmetric slide regulation managed by the unit controller for infinitely modulating capacity from 100% to 25%. An integrated high efficiency oil separator maximizes the oil separation and standard start is Wye-delta (Y- Δ) type.

Refrigerant

The compressors have been designed to operate with R-134a, ecological refrigerant with zero ODP (Ozone Depletion Potential) and very low GWP (Global Warming Potential), resulting in low TEWI (Total Equivalent Warming Impact).

Evaporator (Shell&Tube)

The unit is equipped with a direct expansion shell&tube evaporator with copper tubes rolled into steel tubesheets. The evaporators are single-pass on both the refrigerant and water sides for pure counter-flow heat exchange and low refrigerant pressure drops. Both attributes contribute to the heat exchanger effectiveness and total unit's outstanding efficiency.

The external shell is covered with a 20mm closed cell insulation material and the evaporator water outlet connections are provided with flange kit (as standard). Each evaporator has 2 circuits, one for each compressor and is manufactured in accordance to PED approval.

Condenser (Air – Refrigerant heat exchanger)

The condenser is manufactured with internally enhanced seamless copper tubes arranged in a staggered row pattern and mechanically expanded into lanced and rippled aluminum condenser fins with full fin collars. An integral sub-cooler circuit provides sub-cooling to effectively eliminate liquid flashing and increase cooling capacity without increasing the power input.

Free Cooling (Air – Water heat exchanger)

The Free Cooling heat exchanger is manufactured with internally enhanced seamless copper tubes arranged in a staggered row pattern and mechanically expanded into lanced and rippled aluminum condenser fins with full fin collars.

Condenser fans (\varnothing 800)

The condenser fans are propeller type with high efficiency design blades to maximize performances. The material of the blades is glass reinforced resin and each fan is protected by a guard. Fan motors are protected by circuit breakers (installed inside the electrical panel as a standard) and are IP54. Fan speed regulation is standard available (Option 99).

Electronic expansion valve

The unit is equipped with the most advanced electronic expansion valves to achieve precise control of refrigerant mass flow. As today's system requires improved energy efficiency, tighter temperature control, wider range of operating conditions and incorporate features like remote monitoring and diagnostics, the application of electronic expansion valves becomes mandatory. Electronic expansion valves possess unique features: short opening and closing time, high resolution, positive shut-off function to eliminate use of additional solenoid valve, continuous modulation of mass flow without stress in the refrigerant circuit and corrosion resistance stainless steel body. Electronic expansion valves are typically working with lower ΔP between high and low pressure side, than a thermostatic expansion valve. The electronic expansion valve allows the system to work with low condenser pressure (winter time) without any refrigerant flow problems and with a perfect chilled water leaving temperature control.

Refrigerant circuit

Each unit has 2 independent refrigerant circuits and each one includes:

- Compressor with integrated oil separator
- Air Cooled Condenser
- Electronic expansion valve
- Evaporator
- Discharge line shut off valve
- Liquid line shut off valve
- Suction line shut off valve (optional)
- Sight glass with moisture indicator
- Filter drier
- Charging valves
- High pressure switch
- High and low pressure transducers

GNC_1-2-3-4_Rev.00_1

1
4

4 General Characteristics

4 - 1 General characteristics

Free Cooling Water Circuit

“Standard Glycol” Free Cooling

The principal hydraulic circuit is connected directly (through a three way valve) with the free cooling section, creating a circuit with a water-glycol mixture. The free cooling section includes:

- Air-water heat exchanger
- Three way valve (as standard)

Electrical control panel

Power and control are located in the main panel that is manufactured to ensure protection against all weather conditions. The electrical panel is IP54 and (when opening the doors) internally protected with plexiglas panel against possible accidental contact with electrical components (IP20). The main panel is fitted with a main switch interlocked door.

Power Section

The power section includes compressors fuses, fan circuit breaker, fan contactors and control circuit transformer.

MicroTech III controller

MicroTech III controller is installed as standard; it can be used to modify unit set-points and check control parameters. A built-in display shows chiller operating status plus temperatures and pressures of water, refrigerant and air, programmable values, set-points. A sophisticated software with predictive logic, selects the most energy efficient combination of compressors, EEXV and condenser fans to keep stable operating conditions to maximise chiller energy efficiency and reliability.

MicroTech III is able to protect critical components based on external signs from its system (such as motor temperatures, refrigerant gas and oil pressures, correct phase sequence, pressure switches and evaporator). The input coming from the high pressure switch cuts all digital output from the controller in less than 50ms, this is an additional security for the equipment. Fast program cycle (200ms) for a precise monitoring of the system. Floating point calculations supported for increased accuracy in P/T conversions.

Control section - main features

- Management of the compressor stepless capacity and fans modulation.
- Chiller enabled to work in partial failure condition.
- Full routine operation at condition of:
 - high ambient temperature value
 - high thermal load
 - high evaporator entering water temperature (start-up)
- Display of evaporator entering/leaving water temperature.
- Display of Outdoor Ambient Temperature.
- Display of condensing-evaporating temperature and pressure, suction and discharge superheat for each circuit.
- Leaving water evaporator temperature regulation (temperature tolerance = 0,1°C).
- Compressor and evaporator pumps hours counter.
- Display of Status Safety Devices.
- Number of starts and compressor working hours.
- Optimized management of compressor load.
- Fan management according to condensing pressure.
- Re-start in case of power failure (automatic / manual).
- Soft Load (optimized management of the compressor load during the start-up).
- Start at high evaporator water temperature.
- Return Reset (Set Point Reset based on return water temperature).
- OAT (Outside Ambient temperature) Reset.
- Set point Reset (optional).
- Application and system upgrade with commercial SD cards.
- Ethernet port for remote or local servicing using standard web browsers.
- Two different sets of default parameters could be stored for easy restore.

Safety device / logic for each refrigerant circuit

- High pressure (pressure switch).
- High pressure (transducer).
- Low pressure (transducer).
- Fans circuit breaker.
- High compressor discharge temperature.
- High motor winding temperature.
- Phase Monitor.
- Low pressure ratio.
- High oil pressure drop.
- Low oil pressure.
- No pressure change at start.

GNC_1-2-3-4_Rev.00_2

4 General Characteristics

4 - 1 General characteristics

System security

- Phase monitor.
- Low Ambient temperature lock-out.
- Freeze protection.

Regulation type

Proportional + integral + derivative regulation on the evaporator leaving water output probe.

MicroTech III

MicroTech III built-in terminal has the following features.

- 164x44 dots liquid crystal display with white back lighting. Supports Unicode fonts for multi-lingual.
- Key-pad consisting of 3 keys.
- Push'n'Roll control for an increased usability.
- Memory to protect the data.
- General faults alarm relays.
- Password access to modify the setting.
- Application security to prevent application tampering or hardware usability with third party applications.
- Service report displaying all running hours and general conditions.
- Alarm history memory to allow an easy fault analysis.

Supervising systems (on request)

MicroTech III remote control

MicroTech III is able to communicate to BMS (Building Management System) based on the most common protocols as:

- ModbusRTU
- LonWorks, now also based on the international 8040 Standard Chiller Profile and LonMark Technology.
- BacNet BTP certified over IP and MS/TP (class 4) (Native).
- Ethernet TCP/IP.

Standard Options (supplied on basic unit)

Wye-Delta compressor starter (Y-D) - For low inrush current and reduced starting torque

Double setpoint - Dual leaving water temperature setpoints.

Phase monitor - The phase monitor controls that phases sequence is correct and controls phase loss.

Evaporator flange kit

20mm evaporator insulation - The external shell is covered with a 20mm closed cell insulation material.

Evaporator electric heater - Electric heater (controlled by a thermostat) to protect the evaporator from freezing down to -28°C ambient temperature, providing the power supply is on.

Electronic expansion valve

Discharge line shut-off valve - Installed on the discharge port of the compressor to facilitate maintenance operation.

Ambient outside temperature sensor and setpoint reset

Hour run meter

General fault contactor

Setpoint reset, Demand limit and Alarm from external device - (Set-point reset): The leaving water temperature set-point can be overwritten with the following options: 4-20mA from external source (by user); outside ambient temperature; evaporator water temperature Δt . - (Demand limit): User can limit the load of the unit by 4-20mA signal or by network system. - (Alarm from external device): Microprocessor is able to receive an alarm signal from an external device (eg. pump, etc...). User can decide if this alarm signal will stop or not the unit.

Fans circuit breakers - Safety device against motor overloading and short circuit.

Main switch interlock door

Emergency stop

Fans speed regulation (+ fan silent mode) - To control the fan speed revolution for smooth operating control of the unit. This option improves the sound level of the unit during low ambient temperature operation.

Options (on request)

Soft starter - Electronic starting device to reduce the mechanical stress during compressor start-up

Brine version - Allows the unit to operate down to -8°C leaving liquid temperature (antifreeze required).

Compressor thermal overload relays - Safety devices against compressor motor overloading. This device together with internal motor protection (standard) guarantee the best safety system for compressor motor.

Under / Over voltage control - This device control the voltage value of power supply and stop the chiller if the value exceeds the allowed operating limits.

Energy meter - Device installed inside the control box showing ampere and volt values

GNC_1-2-3-4_Rev.00_3

4 General Characteristics

4 - 1 General characteristics

1

4

Capacitors for power factor correction - To increase the operating power factor of the unit at nominal operating conditions. The capacitors are “dry” self-regenerating type with over pressure disconnecting safety device insulated with a no toxic dielectric mix with no PCB or PCT.

Current limit - To limit maximum absorbed current of the unit whenever is required

Condenser coil guards

Evaporator area guards

Cu-Cu condenser coil - To give better protection against corrosion by aggressive environments.

Cu-Cu-Sn condenser coil - To give better protection against corrosion in aggressive environments and by salty air.

Alucoat fins coil - Fins are protected by a special acrylic paint with a high resistance to corrosion.

Evaporator flow switch - Supplied separately to be wired and installed on the evaporator water piping (by the customer).

Suction line shut-off valve - Installed on the suction port of the compressor to facilitate maintenance operation.

High pressure side manometers

Low pressure side manometers

Rubber anti vibration mounts - Supplied separately, these are positioned under the base of the unit during installation. Ideal to reduce the vibrations when the unit is floor mounted.

Spring anti vibration mounts - Supplied separately, these are positioned under the base of the unit during installation. Ideal for dampening vibrations for installation on roofs and metallic structures.

One centrifugal pump (low lift) - Hydronic kit consists of: single direct driven centrifugal pump, water filling system with pressure gauge, safety valve, drain valve. The motor pump is protected by a circuit breaker installed in control panel. The kit is assembled and wired to the control panel. The pipe and pump are protected from freezing with an additional electrical heater.

One centrifugal pump (high lift) - Hydronic kit consists of: single direct driven centrifugal pump, water filling system with pressure gauge, safety valve, drain valve. The motor pump is protected by a circuit breaker installed in control panel. The kit is assembled and wired to the control panel. The pipe and pump are protected from freezing with an additional electrical heater.

Two centrifugal pump (low lift) - Hydronic kit consists of: twin direct driven centrifugal pumps, water filling system with pressure gauge, safety valve, drain valve. The motor pump is protected by a circuit breaker installed in control panel. The kit is assembled and wired to the control panel. The pipe and pumps are protected from freezing with an additional electrical heater.

Two centrifugal pump (high lift) - Hydronic kit consists of: twin direct driven centrifugal pumps, water filling system with pressure gauge, safety valve, drain valve. The motor pump is protected by a circuit breaker installed in control panel. The kit is assembled and wired to the control panel. The pipe and pumps are protected from freezing with an additional electrical heater.

Double pressure relief valve with diverter

Compressors circuit breakers

Evaporator right water connections

Ground fault relay - To shut down the entire unit if a ground fault condition is detected.

Rapid restart - It allows the unit to start as fast as 30 seconds after power is restored (in case of power failure).

Transport kit

Optimized free cooling (VFD fans regulation) - This option allows the unit having better performances (better efficiency) in the range of temperatures between Starting Free Cooling (starting free cooling is when the outside temperature is one degree below entering water temperature at the free cooling unit) and Free Cooling 100% (free cooling 100% is when the total load of the installation is satisfied by the free cooling).

Optimized free cooling (On/Off fans) - This option allows the unit having better performances (better efficiency) in the range of temperatures between Starting Free Cooling (starting free cooling is when the outside temperature is one degree below entering water temperature at the free cooling unit) and Free Cooling 100% (free cooling 100% is when the total load of the installation is satisfied by the free cooling).

5 Nomenclature

5 - 1 Nomenclature

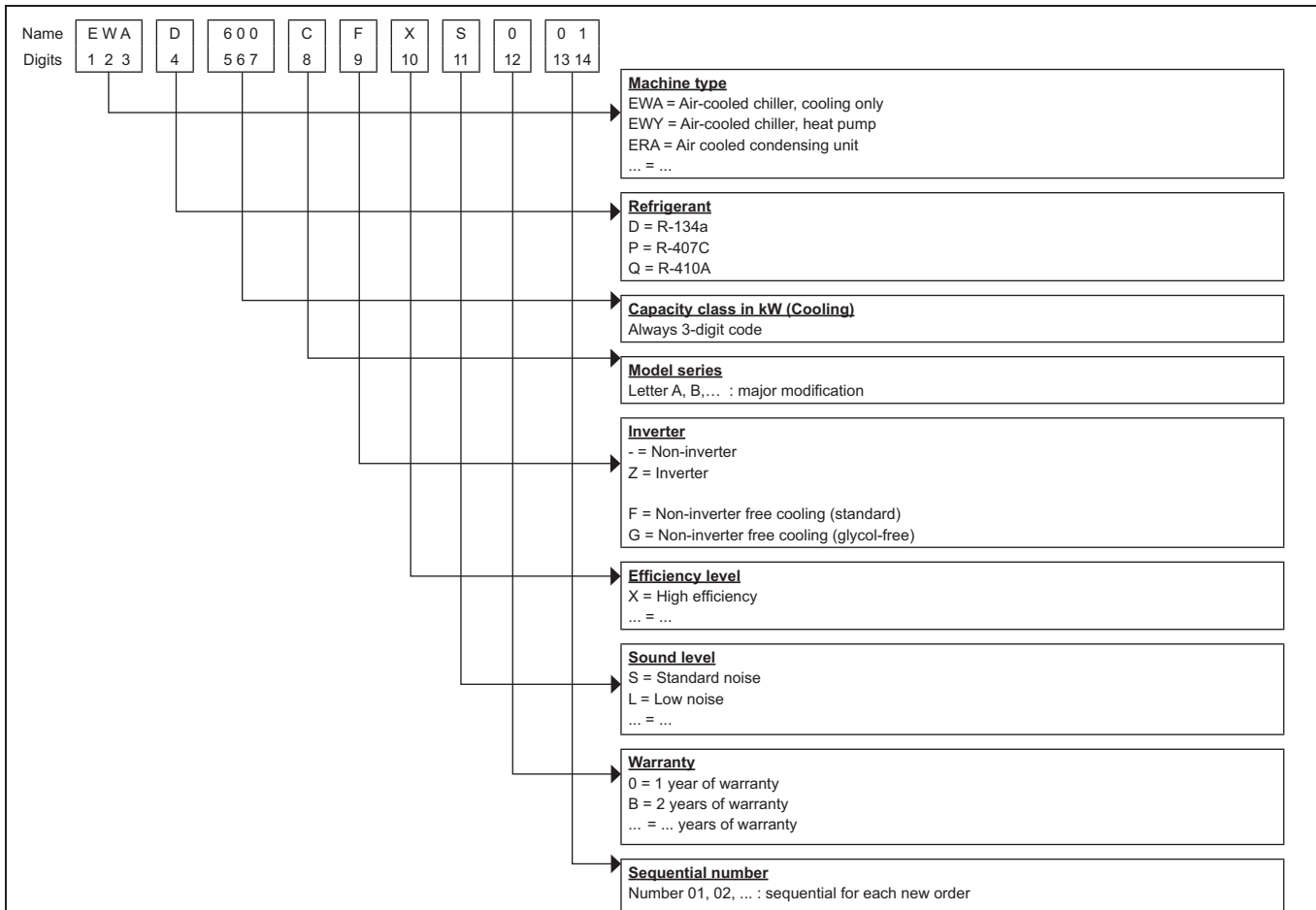

1
5

6 Capacity tables

6 - 1 Cooling Capacity Tables

1
6

EWAD-CFXS Cooling performance													
	Twout	8				9				10			
		Ta	CC	PI	qw	dpw	CC	PI	qw	dpw	CC	PI	qw
		kW	kW	l/s	kPa	kW	kW	l/s	kPa	kW	kW	l/s	kPa
640	25	682	216	29,7	96	700	219	30,4	100	717	223	31,2	105
	30	648	232	28,2	87	664	236	28,9	91	681	240	29,6	95
	32	632	238	27,5	83	649	242	28,2	87	665	247	28,9	91
	35	608	248	26,4	77	624	253	27,1	81	640	257	27,8	85
	38	582	259	25,3	71	597	264	26,0	75	613	269	26,6	78
770	25	563	267	24,5	67	578	271	25,1	71	593	276	25,8	74
	30	789	224	34,3	110	809	228	35,2	115	829	232	36,0	120
	32	765	243	33,3	104	785	247	34,1	108	804	251	34,9	113
	35	754	251	32,8	101	773	255	33,6	105	792	259	34,4	110
	38	735	263	32,0	96	753	268	32,7	101	772	272	33,5	105
850	40	712	276	31,0	91	730	281	31,8	95	748	285	32,5	99
	25	695	285	30,2	87	713	290	31,0	91	731	295	31,7	95
	30	866	242	37,7	94	888	246	38,6	98	910	250	39,6	102
	32	842	263	36,6	89	863	267	37,5	93	884	271	38,4	97
	35	831	271	36,1	87	851	275	37,0	91	872	279	37,9	95
900	38	812	285	35,3	83	832	289	36,2	87	852	293	37,0	90
	40	788	299	34,3	79	809	303	35,1	82	828	308	36,0	86
	25	770	308	33,5	75	790	313	34,4	79	810	318	35,2	82
	30	922	267	40,1	105	943	271	41,0	110	965	275	41,9	114
	32	896	290	39,0	100	916	294	39,8	104	937	299	40,7	108
C10	35	883	300	38,4	97	904	304	39,3	101	924	309	40,2	105
	38	863	315	37,5	93	882	320	38,3	97	902	324	39,2	101
	40	835	331	36,3	88	857	336	37,2	92	876	341	38,1	95
	25	815	341	35,4	84	835	347	36,3	87	856	353	37,2	91
	30	1052	297	45,7	117	1080	302	46,9	123	1108	307	48,1	128
C11	32	1018	322	44,3	110	1045	327	45,4	115	1072	333	46,6	121
	35	1002	332	43,6	107	1029	338	44,7	112	1055	343	45,8	117
	38	976	348	42,4	102	1001	354	43,5	106	1027	360	44,6	111
	40	945	365	41,1	96	969	371	42,1	100	994	377	43,2	105
	25	922	377	40,1	91	945	383	41,1	96	963	386	41,9	99
C12	30	1123	329	48,9	132	1152	335	50,1	139	1180	340	51,3	145
	32	1085	356	47,2	124	1113	362	48,4	130	1140	369	49,5	136
	35	1068	368	46,4	120	1094	374	47,6	126	1121	380	48,7	131
	38	1037	386	45,1	114	1063	393	46,2	119	1089	399	47,3	124
	40	1001	405	43,5	107	1026	412	44,6	112	1052	419	45,7	117
C13	25	974	418	42,4	101	999	425	43,4	106	1011	426	43,9	108
	30	1277	328	55,5	100	1311	332	57,0	105	1345	337	58,4	110
	32	1244	356	54,1	95	1277	361	55,5	100	1310	367	56,9	104
	35	1229	368	53,5	93	1262	373	54,9	97	1295	379	56,3	102
	38	1205	386	52,4	89	1237	392	53,8	94	1269	397	55,1	98
C14	40	1176	405	51,2	85	1207	411	52,5	90	1239	417	53,8	94
	25	1155	418	50,2	82	1185	424	51,5	87	1216	430	52,8	91
	30	1363	362	59,3	113	1398	367	60,8	118	1434	372	62,3	124
	32	1327	393	57,7	107	1361	399	59,2	112	1396	404	60,7	118
	35	1311	406	57,0	105	1345	412	58,4	110	1379	418	59,9	115
C15	38	1283	426	55,8	101	1316	432	57,2	105	1349	439	58,6	110
	40	1251	447	54,4	96	1283	454	55,8	101	1315	460	57,2	105
	25	1227	462	53,4	93	1258	469	54,7	97	1290	476	56,0	101
	30	1457	375	63,3	143	1498	381	65,1	151	1540	388	66,9	158
	32	1413	406	61,4	135	1453	413	63,1	142	1493	420	64,9	149
C16	35	1393	419	60,6	132	1432	426	62,2	138	1471	433	63,9	145
	38	1360	440	59,1	126	1397	447	60,7	132	1435	454	62,4	139
	40	1321	461	57,5	119	1358	468	59,0	125	1394	476	60,6	131
	25	1293	475	56,2	114	1328	483	57,7	120	1364	491	59,3	126
	30	1522	404	66,2	156	1562	410	67,9	163	1602	417	69,6	171
C17	32	1476	439	64,2	147	1515	446	65,9	154	1554	453	67,5	161
	35	1455	454	63,3	143	1493	461	64,9	150	1532	468	66,5	157
	38	1419	476	61,7	136	1456	484	63,3	143	1493	492	64,9	150
	40	1377	500	59,9	129	1413	508	61,4	135	1450	517	63,0	142
	25	1345	517	58,5	123	1381	525	60,0	129	1416	534	61,5	136
C18	30	1591	433	69,2	169	1632	440	71,0	177	1674	447	72,7	185
	32	1542	472	67,1	160	1581	479	68,7	167	1621	487	70,4	175
	35	1520	488	66,1	155	1558	496	67,7	162	1596	504	69,4	170
	38	1481	514	64,4	148	1518	522	66,0	155	1555	530	67,6	162
	40	1434	540	62,4	139	1471	549	64,0	146	1508	558	65,5	152
C19	25	1399	559	60,9	133	1435	568	62,4	139	1472	577	64,0	146

Fluid: Water + Ethylene Glycol 30%
 Ta: Condenser inlet air temperature; Twout: Evaporator leaving water temperature ($\Delta t 6^{\circ}\text{C}$)
 CC: Cooling capacity; PI: Power input; qw: Fluid flow rate; dpw: Fluid pressure drop
 * For working condition where dpw value is "Italic-Red Color" please contact factory

6 Capacity tables

6 - 1 Cooling Capacity Tables

EWAD-CFXS Cooling performance														
	Twout	11					12				13			
		Ta	CC	PI	qw	dpw	CC	PI	qw	dpw	CC	PI	qw	dpw
		kW	kW	l/s	kPa	kW	kW	l/s	kPa	kW	kW	l/s	kPa	
640	25	735	227	31,9	109	753	231	32,7	114	772	235	33,5	119	
	30	698	244	30,3	99	715	248	31,0	104	732	253	31,8	108	
	32	682	251	29,6	95	699	255	30,3	99	715	260	31,0	104	
	35	656	262	28,5	89	672	267	29,2	93	688	271	29,9	97	
	38	628	273	27,3	82	644	278	28,0	86	660	283	28,6	89	
40	608	281	26,4	77	617	282	26,8	79	619	278	26,9	80		
770	25	849	235	36,9	125	870	239	37,8	131	890	243	38,6	136	
	30	823	255	35,8	118	843	259	36,6	123	862	263	37,4	128	
	32	811	263	35,2	115	830	267	36,0	120	849	272	36,9	125	
	35	790	276	34,3	110	809	281	35,1	114	827	285	35,9	119	
	38	766	290	33,3	103	784	294	34,0	108	802	299	34,8	112	
40	748	299	32,5	99	765	304	33,2	103	774	304	33,6	105		
850	25	932	253	40,5	107	953	257	41,4	111	974	261	42,3	116	
	30	906	275	39,3	101	927	279	40,2	106	947	283	41,1	110	
	32	893	284	38,8	99	914	288	39,7	103	935	292	40,6	107	
	35	872	298	37,9	94	893	302	38,8	98	913	307	39,6	103	
	38	848	312	36,8	90	868	317	37,7	93	888	322	38,5	97	
40	830	323	36,0	86	849	328	36,9	90	861	329	37,4	92		
900	25	986	279	42,8	119	1008	283	43,8	124	1030	288	44,7	128	
	30	958	303	41,6	112	979	308	42,5	117	1000	312	43,4	121	
	32	944	313	41,0	110	965	318	41,9	114	986	322	42,8	118	
	35	922	329	40,0	105	941	334	40,9	109	961	339	41,7	113	
	38	895	346	38,9	99	914	351	39,7	103	934	356	40,5	107	
40	875	358	38,0	95	894	363	38,8	99	898	361	39,0	99		
C10	25	1136	312	49,3	134	1164	318	50,5	140	1192	323	51,7	147	
	30	1099	338	47,7	126	1126	344	48,9	132	1153	349	50,0	138	
	32	1082	349	47,0	123	1108	355	48,1	128	1135	361	49,2	134	
	35	1052	366	45,7	116	1078	372	46,8	122	1104	378	47,9	127	
	38	1019	383	44,2	110	1043	390	45,3	114	1062	393	46,1	118	
40	978	387	42,5	101	992	387	43,1	104	1006	387	43,7	107		
C11	25	1209	346	52,5	151	1238	352	53,7	158	1267	358	55,0	165	
	30	1167	375	50,7	142	1195	381	51,9	148	1222	388	53,0	154	
	32	1148	387	49,9	137	1175	393	51,0	143	1201	400	52,1	149	
	35	1114	406	48,4	130	1140	413	49,5	135	1166	420	50,6	141	
	38	1076	426	46,8	122	1101	433	47,8	127	1113	433	48,3	129	
40	1016	422	44,1	109	1021	417	44,3	110	1025	411	44,5	110		
C12	25	1380	342	59,9	115	1415	347	61,4	120	1450	352	62,9	126	
	30	1344	372	58,4	109	1378	377	59,8	114	1412	383	61,3	120	
	32	1328	384	57,7	107	1361	390	59,1	112	1395	395	60,5	117	
	35	1301	403	56,5	103	1334	409	57,9	108	1367	415	59,3	112	
	38	1270	423	55,2	98	1302	429	56,5	103	1334	435	57,9	107	
40	1247	437	54,2	95	1278	443	55,5	99	1310	449	56,8	104		
C13	25	1470	378	63,9	130	1507	384	65,4	135	1544	389	67,0	142	
	30	1431	410	62,2	123	1466	417	63,7	129	1502	423	65,2	134	
	32	1413	424	61,4	120	1448	430	62,9	126	1483	437	64,4	131	
	35	1383	445	60,1	115	1417	452	61,5	121	1451	458	63,0	126	
	38	1348	467	58,5	110	1381	474	59,9	115	1414	481	61,3	120	
40	1321	483	57,4	106	1353	490	58,8	111	1386	497	60,1	115		
C14	25	1581	394	68,7	166	1623	401	70,5	174	1665	408	72,3	183	
	30	1533	427	66,6	157	1573	434	68,3	164	1614	442	70,0	172	
	32	1511	441	65,6	153	1551	448	67,3	160	1591	456	69,0	168	
	35	1474	462	64,0	146	1513	469	65,7	153	1552	477	67,3	160	
	38	1431	484	62,2	138	1469	492	63,8	144	1506	500	65,4	151	
40	1400	499	60,8	132	1436	507	62,3	138	1473	515	63,9	145		
C15	25	1643	424	71,4	179	1684	430	73,1	187	1725	437	74,9	195	
	30	1593	460	69,2	169	1632	468	70,9	176	1672	475	72,5	184	
	32	1570	476	68,2	164	1608	483	69,8	172	1647	491	71,5	179	
	35	1531	500	66,5	157	1569	508	68,1	164	1606	516	69,7	171	
	38	1486	525	64,5	148	1522	533	66,1	155	1559	542	67,7	161	
40	1452	542	63,1	142	1488	551	64,6	148	1509	552	65,5	152		
C16	25	1715	454	74,5	194	1758	462	76,3	203	1800	469	78,1	212	
	30	1661	495	72,1	182	1701	503	73,8	190	1741	511	75,6	199	
	32	1635	512	71,0	177	1675	520	72,7	185	1714	529	74,4	193	
	35	1593	539	69,2	169	1630	547	70,8	176	1668	556	72,4	183	
	38	1544	567	67,1	159	1580	576	68,6	166	1617	585	70,2	173	
40	1508	586	65,5	152	1543	596	67,0	159	1550	590	67,3	160		

Fluid: Water + Ethylene Glycol 30%

Ta: Condenser inlet air temperature; Twout: Evaporator leaving water temperature (Δt 6°C)

CC: Cooling capacity; PI: Power input; qw: Fluid flow rate; dpw: Fluid pressure drop

* For working condition where dpw value is "Italic-Red Color" please contact factory

6 Capacity tables

6 - 1 Cooling Capacity Tables

EWAD-CFXS
Free cooling performance

Twout	8					9					10				
	TFC °C	CC kW	PI kW	qw l/s	dpw kPa	TFC °C	CC kW	PI kW	qw l/s	dpw kPa	TFC °C	CC kW	PI kW	qw l/s	dpw kPa
640	-2,1	608	19,1	26,4	117	-1,5	624	19	27,1	123	-0,8	640	19,1	27,8	128
770	-1,4	735	22,7	32	158	-0,8	753	22,6	32,7	165	-0,1	772	22,6	33,5	172
850	-0,2	812	26,2	35,3	164	0,5	832	26,2	36,2	171	1,2	852	26,3	37	178
900	-1,0	863	26,2	37,5	183	-0,3	882	26,2	38,3	190	0,4	902	26,2	39,2	198
C10	-0,4	976	29,9	42,4	224	0,2	1001	29,7	43,5	234	0,9	1027	29,8	44,6	245
C11	-1,2	1037	30	45,1	250	-0,6	1063	29,8	46,2	261	0,1	1089	29,9	47,3	272
C12	1,6	1205	37,1	52,4	212	2,2	1237	36,8	53,8	222	2,9	1269	36,8	55,1	232
C13	0,8	1283	37	55,8	238	1,5	1316	37,1	57,2	248	2,1	1349	36,8	58,6	259
C14	0,0	1360	36,8	59,1	278	0,7	1397	37,1	60,7	291	1,3	1435	37	62,4	305
C15	-0,5	1419	37,1	61,7	300	0,1	1456	37	63,3	314	0,7	1493	36,9	64,9	328
C16	-1,2	1481	36,8	64,4	324	-0,5	1518	37	66	339	0,1	1555	36,9	67,6	354

Fluid: Water + Ethylene Glycol 30%

Ta: Outdoor air temperature; Twout: unit leaving water temperature (Δt 6°C)

TFC: Air temperature for Free Cooling 100%; CC: Cooling capacity; PI: Power input; qw: Fluid flow rate; dpw: Fluid pressure drop

6 Capacity tables

6 - 1 Cooling Capacity Tables

EWAD-CFXS
Free cooling performance

Twout	11					12					13				
	TFC °C	CC kW	PI kW	qw l/s	dpw kPa	TFC °C	CC kW	PI kW	qw l/s	dpw kPa	TFC °C	CC kW	PI kW	qw l/s	dpw kPa
640	-0,1	656	19,2	28,5	134	0,5	672	19,1	29,2	140	1,2	688	19,1	29,9	146
770	0,6	790	22,7	34,3	179	1,3	809	22,7	35,1	186	2,0	827	22,8	35,9	194
850	1,9	872	26,3	37,9	186	2,6	893	26,3	38,8	193	3,3	913	26,4	39,6	201
900	1,1	922	26,2	40	205	1,8	941	26,2	40,9	213	2,5	961	26,2	41,7	221
C10	1,5	1052	29,7	45,7	255	2,2	1078	29,8	46,8	267	2,9	1104	29,9	47,9	278
C11	0,7	1114	29,8	48,4	284	1,4	1140	29,9	49,5	295	2,0	1166	29,8	50,6	307
C12	3,6	1301	36,9	56,5	242	4,3	1334	37	57,9	253	5,0	1367	37,1	59,3	264
C13	2,8	1383	37	60,1	271	3,5	1417	37,1	61,5	282	4,1	1451	36,8	63	294
C14	1,9	1474	36,9	64	320	2,5	1513	36,9	65,7	335	3,1	1552	36,8	67,3	350
C15	1,4	1531	37,1	66,5	343	2,0	1569	37	68,1	358	2,6	1606	36,9	69,7	373
C16	0,7	1593	36,8	69,2	369	1,4	1630	37,1	70,8	384	2,0	1668	37	72,4	400

Fluid: Water + Ethylene Glycol 30%

Ta: Outdoor air temperature; Twout: unit leaving water temperature (Δt 6°C)

TFC: Air temperature for Free Cooling 100%; CC: Cooling capacity; PI: Power input; qw: Fluid flow rate; dpw: Fluid pressure drop

7 Dimensional drawings

7 - 1 Dimensional Drawings

EWAD CFX- (Standard Glycol)

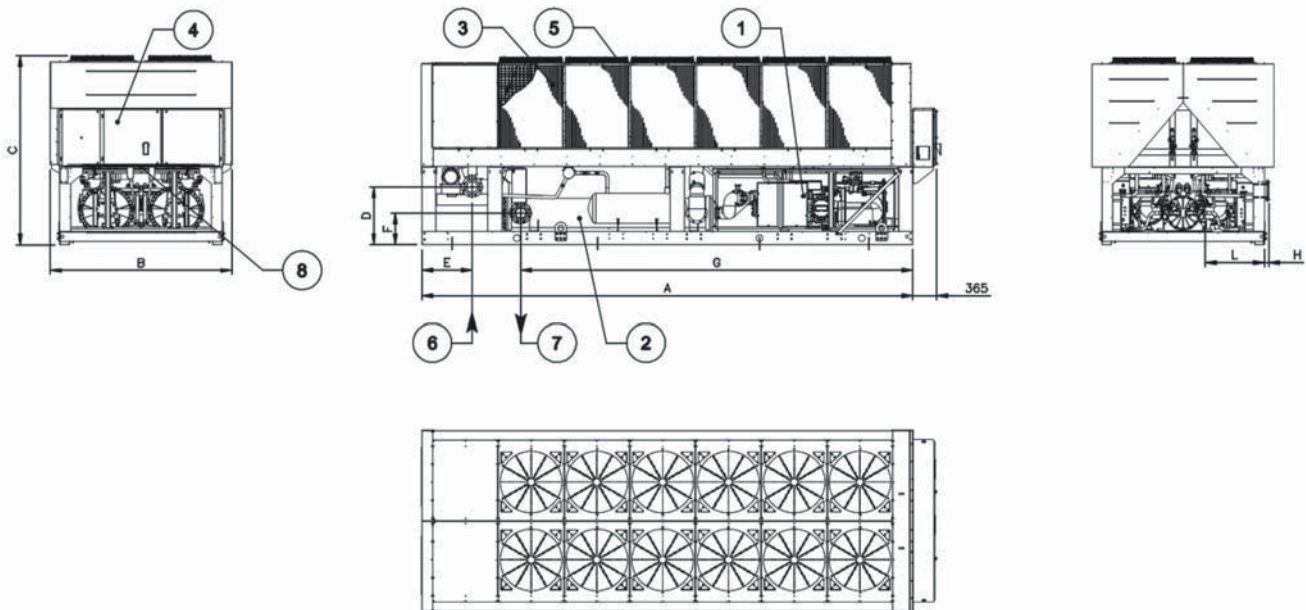

The drawing is for illustration only. Please refer to the table below for unit dimensions.

Models		Dimensions (mm)									
EWAD CFXS/XL	EWAD CFXR	A	B	C	D	E	F	G	H	I	Fans
640	600	5820	2480	2565	795	690	435	5370	75	800	10
770	740	6720	2480	2565	795	690	435	5370	75	800	12
850	820	7620	2480	2565	795	690	435	5370	75	800	14
900	870	7620	2480	2565	795	690	435	5370	75	800	14
C10	980	8520	2480	2565	795	690	540	5355	75	748	16
C11	C10	8520	2480	2565	795	690	540	5355	75	748	16
C12	C11	10320	2480	2565	795	690	540	5355	75	748	20
C13	C12	10320	2480	2565	795	690	540	5355	75	748	20
C14	C13	10320	2480	2565	795	690	540	5355	75	670	20
C15	C14	10320	2480	2565	795	690	540	5355	75	670	20
C16	C15	10320	2480	2565	795	690	540	5355	75	670	20

LEGEND

- 1 – Compressor
- 2 – Evaporator
- 3 – Condenser coil
- 4 – Electrical panel
- 5 – Fan
- 6 – Evaporator water inlet
- 7 – Evaporator water outlet
- 8 – Power connections slot

8 Sound data

8 - 1 Sound Level Data

EWAD-CFXS

MODEL	Sound pressure level at 1 m from the unit (rif. 2 x 10 ⁻⁵ Pa)									Power dB(A)
	63 Hz	125 Hz	250 Hz	500 Hz	1000 Hz	2000 Hz	4000 Hz	8000 Hz	dB(A)	
640	73,9	76,0	78,8	78,0	73,9	69,4	59,8	50,7	79,0	99,5
770	74,6	76,7	79,5	78,7	74,6	70,1	60,5	51,4	79,7	100,2
850	74,6	76,7	79,5	78,7	74,6	70,1	60,5	51,4	79,7	100,5
900	74,6	76,7	79,5	78,7	74,6	70,1	60,5	51,4	79,7	100,5
C10	75,1	77,2	80,0	79,2	75,1	70,6	61,0	51,9	80,2	101,4
C11	75,6	77,7	80,5	79,7	75,6	71,1	61,5	52,4	80,7	101,9
C12	75,2	77,3	80,1	79,3	75,2	70,7	61,1	52,0	80,3	102,4
C13	75,3	77,4	80,2	79,4	75,3	70,8	61,2	52,1	80,4	102,5
C14	75,3	77,4	80,2	79,4	75,3	70,8	61,2	52,1	80,4	102,5
C15	75,3	77,4	80,2	79,4	75,3	70,8	61,2	52,1	80,4	102,5
C16	75,3	77,4	80,2	79,4	75,3	70,8	61,2	52,1	80,4	102,5

NOTES

Fluid: Water + Ethylene Glycol 30%

Note: The values are according to ISO 3744 and are referred to: evaporator 12/7° C, air ambient 35°C, full load operation

NSL_1-2-3_Rev.00_1

9 Installation

9 - 1 Installation Method

Installation notes

Warning

Installation and maintenance of the unit must be performed only by qualified personnel who have knowledge with local codes and regulations, and experience with this type of equipment. Must be avoided the unit installation in places that could be considered dangerous for all the maintenance operations.

Handling

Care should be taken to avoid rough handling or shock due to dropping the unit. Do not push or pull the unit from anything other than the base frame. Never allow the unit to fall during unloading or moving as this may result in serious damage. To lift the unit, rings are provided in the base frame of the unit. Spreader bar and cables should be arranged to prevent damage to the condenser coil or unit cabinet.

Location

The units are produced for outside installation on roofs, floors or below ground level on condition that the area is free from obstacles for the passage of the condenser air. The unit should be positioned on solid foundations and perfectly level; in the case of installation on roofs or floors, it may be advisable to arrange the use of suitable weight distribution beams. When the units are installed on the ground, a concrete base at least 250 mm wider and longer than the unit's footprint should be laid. Furthermore, this base should withstand the unit weight mentioned in the technical data table.

Space requirements

The units are air-cooled, then it is important to respect the minimum distances which guarantee the best ventilation of the condenser coils. Limitations of space reducing the air flow could cause significant reductions in cooling capacity and an increase in electricity consumption.

To determinate unit placement, careful consideration must be given to assure a sufficient air flow across the condenser heat transfer surface. Two conditions must be avoided to achieve the best performance: warm air recirculation and coil starvation. Both these conditions cause an increase of condensing pressures that results in reductions in unit efficiency and capacity.

Moreover the unique microprocessor has the ability to calculate the operating environment of the air cooled chiller and the capacity to optimize its performance staying on-line during abnormal conditions.

Each side of the unit must be accessible after installation for periodic service. Fig.1 shows you minimum recommended clearance requirements.

Vertical condenser air discharge must be unobstructed because the unit would have its capacity and efficiency significantly reduced.

If the units are positioned in places surrounded by walls or obstacles of the same height as the units, the units should be at least 2500 mm from obstacles (fig.2). In the event the obstacles are higher than the units, the units should be at least 3000 mm from the obstacle (fig.4). Units installed closer than the minimum recommended distance to a wall or other vertical riser may experience a combination of coil starvation and warm air recirculation, thus causing reduction in unit capacity and efficiency reductions. The microprocessor control is proactive in response "of design condition". In the case of single or compounded influences restricting airflow to the unit, the microprocessor will act to keep the compressor(s) running (at reduced capacity) rather than allowing a shut-off on high discharge pressure.

When two or more units are positioned side by side it is recommended that the condenser coils are at least 3600 mm distance from one another (fig.3); strong wind could be the cause of air warm recirculation.

For other installation solutions, consult our technicians.

The above recommended information are representative of general installation. A specific evaluation should be done by contractor depending on the case.

9 Installation

9 - 1 Installation Method

Fig. 1

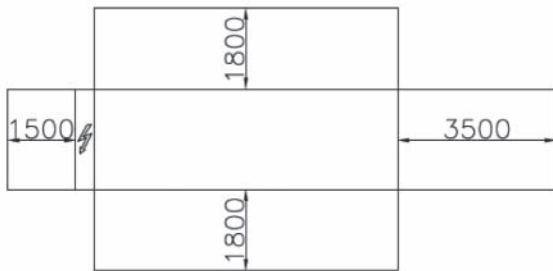

Fig. 2

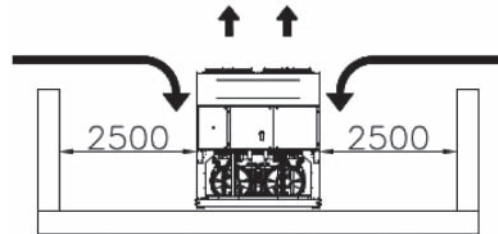

Fig. 3

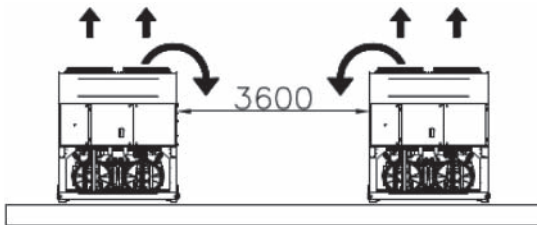
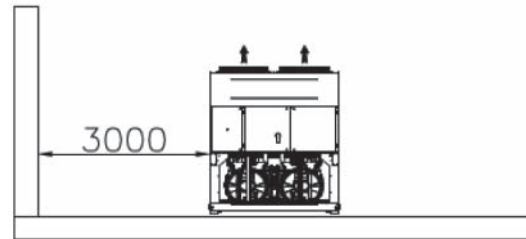

Fig. 4



Acoustic protection

When noise level must meet special requirements, it is necessary to pay the maximum attention to ensure the perfect insulation of the unit from the support base by applying appropriate vibration-dampening devices on the unit, on the water pipes and on the electrical connections.

Storage

The environment conditions have to be in the following limits:

Minimum ambient temperature:	-20°C
Maximum ambient temperature:	+57°C
Maximum R.H.:	95% not condensing

9 Installation

9 - 2 Water Charge, Flow and Quality

Water charge, flow and quality

Items ^{(1) (5)}	Cooling Water			Cooled Water	Heated water ⁽²⁾				Tendency if out of criteria			
	Circulating System		Once Flow		Low temperature		High temperature					
	Circulating water	Supply water ⁽⁴⁾	Flowing water	Circulating water [Below 20°C]	Supply water ⁽⁴⁾	Circulating water [20°C ~ 60°C]	Supply water ⁽⁴⁾	Circulating water [60°C ~ 80°C]		Supply water ⁽⁴⁾		
pH	at 25°C		6.5 ~ 8.2	6.0 ~ 8.0	6.0 ~ 8.0	6.8 - 8.0	6.0 ~ 8.0	7.0 ~ 8.0	7.0 ~ 8.0	7.0 ~ 8.0	7.0 ~ 8.0	Corrosion + Scale
Electrical conductivity	[mS/m] at 25°C		Below 80	Below 30	Below 40	Below 80	Below 80	Below 30	Below 30	Below 30	Below 30	Corrosion + Scale
	[μS/cm] at 25°C		(Below 800)	(Below 300)	(Below 400)	(Below 800)	(Below 800)	(Below 300)	(Below 300)	(Below 300)	(Below 300)	Corrosion + Scale
Chloride ion	[mgCl ⁻ /l]		Below 200	Below 50	Below 50	Below 200	Below 50	Below 50	Below 50	Below 30	Below 30	Corrosion
Sulfate ion	[mgSO ₄ ²⁻ /l]		Below 200	Below 50	Below 50	Below 200	Below 50	Below 50	Below 50	Below 30	Below 30	Corrosion
M-alkalinity (pH4.8)	[mgCaCO ₃ /l]		Below 100	Below 50	Below 50	Below 100	Below 50	Below 50	Below 50	Below 50	Below 50	Scale
Total hardness	[mgCaCO ₃ /l]		Below 200	Below 70	Below 70	Below 200	Below 70	Below 70	Below 70	Below 70	Below 70	Scale
Calcium hardness	[mgCaCO ₃ /l]		Below 150	Below 50	Below 50	Below 50	Below 50	Below 50	Below 50	Below 50	Below 50	Scale
Silica ion	[mgSiO ₂ /l]		Below 50	Below 30	Below 30	Below 30	Below 30	Below 30	Below 30	Below 30	Below 30	Scale
Oxygen	(mg O ₂ /l)		Below 1.0	Below 1.0	Below 1.0	Below 1.0	Below 1.0	Below 1.0	Below 1.0	Below 1.0	Below 1.0	Corrosion
Particole size	(mm)		Below 0.5	Below 0.5	Below 0.5	Below 0.5	Below 0.6	Below 0.5	Below 0.6	Below 0.5	Below 0.6	Erosion
Total dissolved solids	(mg /l)		Below 1000	Below 1000	Below 1000	Below 1000	Below 1001	Below 1000	Below 1001	Below 1000	Below 1001	Erosion
Ethykene, Propylene Glycol (weight conc.)			Below 60%	Below 60%	---	Below 60%	Below 60%	Below 60%	Below 60%	Below 60%	Below 60%	--
Nitrate ion	(mg NO ₃ ⁻ /l)		Below 100	Below 100	Below 100	Below 100	Below 101	Below 100	Below 101	Below 100	Below 101	Corrosion
TOC Total organic carbon	(mg /l)		Below 1.0	Below 1.0	Below 1.0	Below 1.0	Below 1.0	Below 1.0	Below 1.0	Below 1.0	Below 1.0	Scale
Iron	[mgFe/l]		Below 1.0	Below 0.3	Below 1.0	Below 1.0	Below 0.3	Below 1.0	Below 0.3	Below 1.0	Below 0.3	Corrosion + Scale
Copper	[mgCu/l]		Below 0.3	Below 0.1	Below 1.0	Below 1.0	Below 1.0	Below 1.0	Below 0.1	Below 1.0	Below 0.1	Corrosion
Sulfite ion	[mgS ²⁻ /l]		Not detectable	Not detectable	Not detectable	Not detectable	Not detectable	Not detectable	Not detectable	Not detectable	Not detectable	Corrosion
Ammonium ion	[mgNH ₄ ⁺ /l]		Below 1.0	Below 0.1	Below 1.0	Below 1.0	Below 0.1	Below 0.3	Below 0.1	Below 0.1	Below 0.1	Corrosion
Remaining chloride	[mgCl/l]		Below 0.3	Below 0.3	Below 0.3	Below 0.3	Below 0.3	Below 0.25	Below 0.3	Below 0.1	Below 0.3	Corrosion
Free carbide	[mgCO ₂ /l]		Below 4.0	Below 4.0	Below 4.0	Below 4.0	Below 4.0	Below 0.4	Below 4.0	Below 0.4	Below 4.0	Corrosion
Stability index			6.0 ~ 7.0	---	---	---	---	---	---	---	---	Corrosion + Scale

Items to be controlled:

Items to be referred to:

9 Installation

9 - 2 Water Charge, Flow and Quality

Water content in cooling circuits

The cooled water distribution circuits should have minimum water content to avoid excessive compressors start and stop. In fact, each time the compressor starts up, an excessive quantity of oil goes from the compressor sump and simultaneously there is a rise in the temperature of the compressor motor's stator due to the inrush current during the start-up. To prevent damage to the compressors, it has been envisaged the application of a device to limit frequent stops and restarts.

During the span of one hour there will be no more than 6 starts of the compressor. The plant side should therefore ensure that the overall water content allows a more constant functioning of the unit and consequently greater environmental comfort. The minimum water content per unit should be calculated using this simplified formula:

For 2 compressors unit

$$M \text{ (liters)} = (0.1595 \times \Delta T(^{\circ}\text{C}) + 3.0825) \times P(\text{kW})$$

where:

- M minimum water content per unit expressed in litres
- P Cooling Capacity of the unit expressed in kW
- ΔT evaporator entering / leaving water temperature difference expressed in $^{\circ}\text{C}$

This formula is valid for:

- standard microprocessor parameters

For more accurate determination of quantity of water, it is advisable to contact the designer of the plant.

10 Operation range

10 - 1 Operation Range

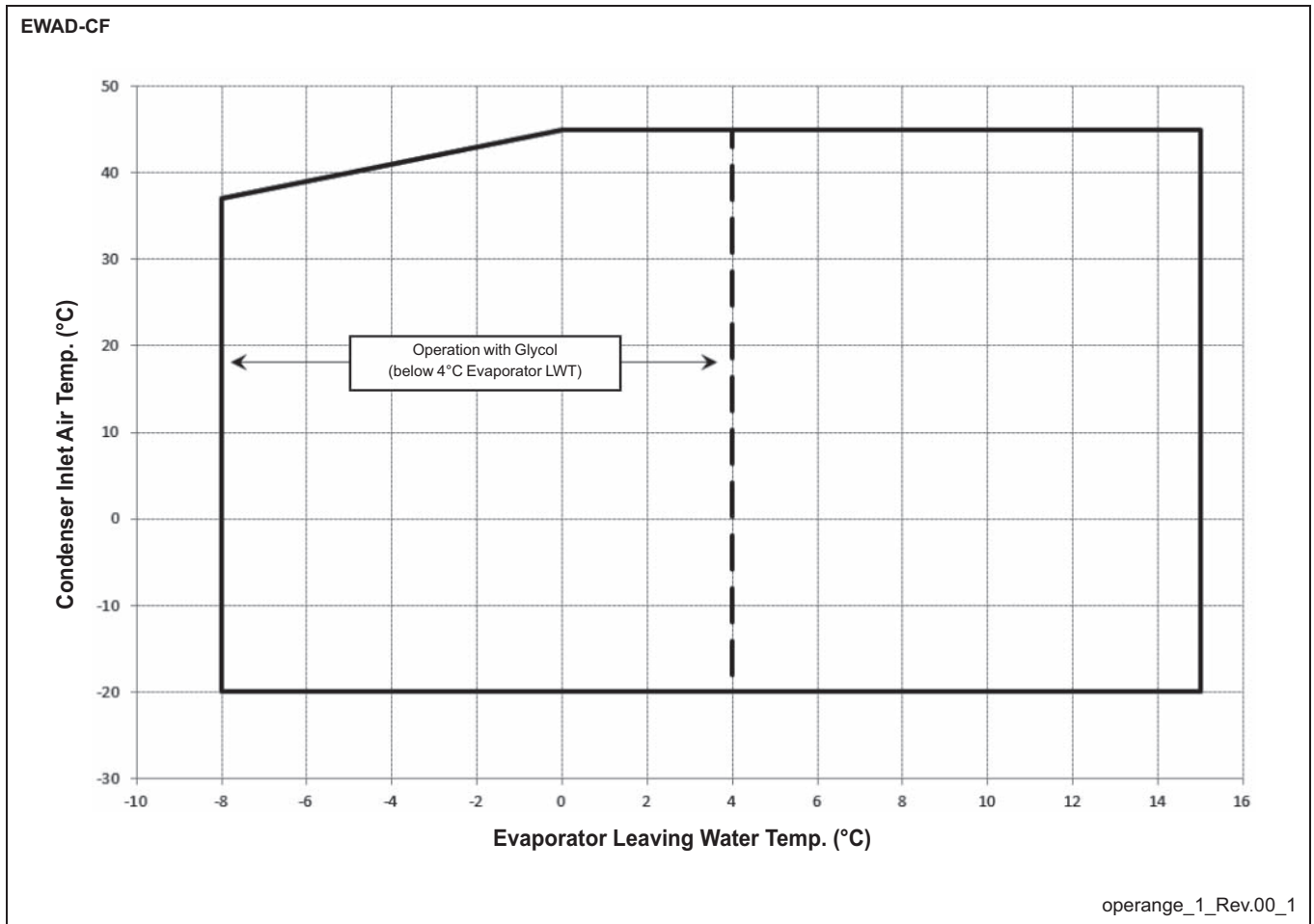

1
10

11 Specification text

11 - 1 Specification Text

Technical specification for air cooled chiller

General

The chiller will be designed and manufactured in accordance with the following European directives:

Construction of pressure vessel	97/23/EC (PED)
Machinery Directive	2006/42/EC
Low Voltage	2006/95/EC
Electromagnetic Compatibility	2004/108/EC
Electrical & Safety codes	EN 60204-1 / EN 60335-2-40
Manufacturing Quality Standards	UNI – EN ISO 9001:2004

To avoid any losses, the unit will be tested at full load in the factory (at the nominal working conditions and water temperatures). The chiller will be delivered to the job site completely assembled and charged with refrigerant and oil. The installation of the chiller must comply with the manufacturer's instructions for rigging and handling equipment.

The unit will be able to start up and operate (as standard) at full load with:

- outside air temperature from °C to °C
- evaporator leaving fluid temperature between °C and °C

Refrigerant

Only R-134a can be used.

Performance

- ✓ Number of air cooled screw chiller(s) : unit(s)
- ✓ Cooling capacity for single chiller : kW
- ✓ Power input for single chiller in cooling mode : kW
- ✓ Heat exchanger entering water temperature in cooling mode : °C
- ✓ Heat exchanger leaving water temperature in cooling mode : °C
- ✓ Heat exchanger water flow : l/s
- ✓ Nominal outside working ambient temperature in cooling mode : °C
- ✓ Operating voltage range should be 400V ±10%, 3ph, 50Hz, voltage unbalance maximum 3%, without neutral conductor and shall only have one power connection point.

Unit description

Chiller shall include as standard not less than: two independent refrigerant circuits, semi-hermetic asymmetric type rotary single screw compressors, electronic expansion device (EEXV), refrigerant direct expansion shell & tube heat exchanger, air-cooled condenser section, R134a refrigerant, lubrication system, motor starting components, discharge line shut-of valve, control system and all components necessary for safe and stable unit operation.

Chiller will be factory assembled on a robust base-frame made of galvanized steel, protected by an epoxy paint.

Sound level and vibrations

Sound pressure level at 1 meter distance in free field, semispheric conditions, shall not exceeddB(A). The sound pressure levels must be rated in accordance to ISO 3744. Other types of rating unacceptable. Vibration on the base frame should not exceed 2 mm/s.

Dimensions

Unit dimensions shall not exceed following indications:

- Unit length : mm
- Unit width : mm
- Unit height : mm

Chiller components

Compressors

- ✓ Semi-hermetic, single-screw asymmetric type with one main helical rotor meshing with two diametrical opposed gatorotors. The gatorotors' contact elements shall be constructed of composite material designed for extended life. Electrical motor shall be 2-pole, semi-hermetic, squirrel-cage induction type and cooled by suction gas.
- ✓ The oil injection shall be used in order to get high EER (Energy Efficiency Ratio) also at high condensing pressure and low sound pressure levels in each load condition.
- ✓ The compressor shall be provided with a built in, high efficiency, mesh type oil separator and oil filter.
- ✓ Refrigerant system differential pressure shall provide oil injection on all moving compressor parts to correctly lubricate them. Electrical oil pump lubricating system is not acceptable.

11 Specification text

11 - 1 Specification Text

1

11

- ✓ Compressor cooling must be done by refrigerant liquid injection. External dedicated heat exchanger and additional piping to carry the oil from the compressor to heat exchanger and viceversa will be not accepted.
- ✓ The compressor shall be direct electrical driven, without gear transmission between the screw and the electrical motor.
- ✓ The compressor casing shall be provided with ports to realize economized refrigerant cycles.
- ✓ Compressor must be protected by temperature sensor for high discharge temperature and electrical motor thermistor for high winding temperature.
- ✓ The compressor shall be equipped with an electric oil heater.
- ✓ Compressor shall be fully field serviceable. Compressor that must be removed and returned to the factory for service shall be unacceptable.

Cooling capacity control system

- ✓ Each chiller will have a microprocessor for the control of compressor slide valve position.
- ✓ The unit capacity control shall be infinitely modulating, from 100% down to 25% for each circuit (from 100% down to 12,5% of full load for unit with 2 compressors. The chiller shall be capable of stable operation to a minimum of 12,5% of full load without hot gas bypass.
- ✓ The system shall control the unit based on the leaving evaporator water temperature that shall be controlled by a PID (Proportional Integral Derivative) logic.
- ✓ Unit control logic shall manage the compressor slides to exactly match plant load request in order to keep constant the set point for delivered chilled water temperature.
- ✓ The microprocessor unit control shall detect conditions that approach protective limits and take self-corrective action prior to an alarm occurring. The system shall automatically reduce chiller capacity when any of the following parameters are outside their normal operating range:
 - High condenser pressure
 - Low evaporating refrigerant temperature

Evaporator

- ✓ The units shall be equipped with a Direct Expansion shell&tube evaporator with copper tubes rolled into steel tubesheets. The evaporator shall be single-pass on both the refrigerant and water sides for pure counter-flow heat exchange and low refrigerant pressure drops.
- ✓ The external shell shall be linked with an electrical heater to prevent freezing down to -28°C ambient temperature, controlled by a thermostat and shall be insulated with flexible, closed cell polyurethane insulation material (20-mm thick).
- ✓ The evaporator will have 2, one for each compressor and shall be single refrigerant pass.
- ✓ The water connections shall be FLANGED type connections as standard to ensure quick mechanical disconnection between the unit and the hydronic network.
- ✓ Evaporator is manufactured in accordance to PED approval.

Condenser coil

- ✓ The condenser coils are constructed with internally finned seamless copper tubes having a “W” configuration and arranged in a staggered row pattern and mechanically expanded into lanced and rippled aluminium fins with full fin collars for higher efficiencies. The space between the fins are given by a collar that will increase the surface area in connection with the tubes, protecting them from ambient corrosion.
- ✓ The coils will have an integral subcooler circuit that provides sufficient subcooling to effectively eliminate the possibility of liquid flashing and increase the unit's efficiency of 5-7% without increasing in energy consumption.
- ✓ The condenser coil shall be leak-tested and submitted to a pressure test with dry air.

Condenser fans

- ✓ The fans used in conjunction with the condenser coils, shall be propeller type with glass reinforced resin blades for higher efficiencies and lower noise. Each fan shall be protected by a fan guard.
- ✓ The air discharge shall be vertical and each fan must be coupled to the electrical motor, supplied as standard to IP54 and capable to work to ambient temperatures of - 20°C to + 65°C.
- ✓ They shall have as a standard a thermally protection by internal therma motor protection and protected by ciurcuit braker installed inside the electrical panel as a standard.

Refrigerant circuit

- ✓ The unit must have multiple independent refrigerant circuits.
- ✓ Each circuit shall include as standard: electronic expansion device piloted by unit's microprocessor control, compressor discharge shut-off valve, replaceable core filter-drier, sight glass with moisture indicator and insulated suction line.

Condensation control

- ✓ The units will be provided with an automatic control for condensing pressure which ensures the working at low external temperatures down to - °C, to maintain condensing pressure.
- ✓ Compressor automatically unloads when abnormal high condensing pressure is detected to prevent the shutdown of the refrigerant circuit (shutdown of the unit) due to a high-pressure fault.

11 Specification text

11 - 1 Specification Text

Low sound unit options (on request)

- ✓ The unit compressors shall be connected with unit's metal base frame by rubber antivibration supports to prevent the transmission of vibrations to all metal unit structure and so to control the unit noise.
- ✓ The chiller shall be provided with an acoustically compressor enclosure. This enclosure shall be realized with a light, corrosion resisting aluminium structure and metal panels. The compressors sound-proof enclosure shall be internally fitted with flexible, multi layer, high density materials.

Hydronic kit options (on request)

- ✓ The hydronic module shall be integrated in the chiller chassis without increasing its dimensions and include the following elements: centrifugal water pump with three-phase motor equipped with internal over-temperature protection, safety relief valve, filling kit.
- ✓ The water piping shall be protected against corrosion and equipped with drain and purge plugs. The customer connections shall be Victaulic connections. The piping shall be fully insulated to prevent condensation (pump insulation using polyurethane foam).
- ✓ A choice of two pump types shall be available on unit with 2 compressors:
 - in-line single pump
 - in-line twin pumps

Control panel

- ✓ Field power connection, control interlock terminals, and unit control system should be centrally located in an electric panel (IP 54). Power and starting controls should be separate from safety and operating controls in different compartments of the same panel.
- ✓ Starting will be Wye-Delta type (Y-Δ).
- ✓ Operating and safety controls should include energy saving control; emergency stop switch; overload protection for compressor motor; high and low pressure cut-out switch (for each refrigerant circuit); anti-freeze thermostat; cut-out switch for each compressor.

All of the information regarding the unit will be reported on a display and with the internal built-in calendar and clock that will switch the unit ON/OFF during day time all year long.

- ✓ The following features and functions shall be included:
 - leaving water temperature reset by controlling the water temperature Δt , by a remote 4-20mA DC signal or by controlling the external ambient temperature;
 - soft load function to prevent the system from operating at full load during the chilled fluid pulldown period;
 - password protection of critical parameters of control;
 - start-to-start and stop-to-start timers to provide minimum compressor off-time with maximum motor protection;
 - communication capability with a PC or remote monitoring;
 - discharge pressure control through intelligent cycling of condenser fans;
 - lead-lag selection by manual or automatically by circuit run hours;
 - double set point for brine unit version;
 - scheduling via internal time clock to allow programming of a yearly start-stop schedule accommodating weekends and holidays.

Optional High Level Communications Interface

Chiller must be able to communicate to BMS (Building Management System) based on the most common protocols as:

- ModbusRTU
- LonWorks, now also based on the international 8040 Standard Chiller Profile and LonMark Technology
- BacNet BTP certified over IP and MS/TP (class 4) (Native)
- Ethernet TCP/IP.

TABLE OF CONTENTS

EWAD-CFXL

1	Features	34
2	Specifications	35
	Technical Specifications	35
	Electrical Specifications	36
3	Features and advantages	37
	Features and Advantages	37
4	General Characteristics	39
	General characteristics	39
5	Nomenclature	43
	Nomenclature	43
6	Capacity tables	44
	Cooling Capacity Tables	44
7	Dimensional drawings	48
	Dimensional Drawings	48
8	Sound data	49
	Sound Level Data	49
9	Installation	50
	Installation Method	50
	Water Charge, Flow and Quality	52
10	Operation range	54
	Operation Range	54
11	Specification text	55
	Specification Text	55

1 Features

- High efficiency, low sound levels
- Free cooling chiller
- Greater energy savings and reduced CO² emissions during cold season
- Wide capacity range: 11 sizes between 600 and 1.565 kW
- Wide operating range
- MicroTech III controller



2

1

2 Specifications

2-1 Technical Specifications				EWAD 640CFXL	EWAD 770CFXL	EWAD 850CFXL	EWAD 900CFXL	EWAD C10CFXL	EWAD C11CFXL	EWAD C12CFXL	EWAD C13CFXL	EWAD C14CFXL	EWAD C15CFXL	EWAD C16CFXL	
Cooling capacity	Nom.	kW		640(1)/ 295(2)	772(1)/ 365(2)	852(1)/ 413(2)	902(1)/ 434(2)	1,027(1)/ 502(2)	1,089(1)/ 524(2)	1,269(1)/ 594(2)	1,349(1)/ 652(2)	1,435(1)/ 663(2)	1,493(1)/ 659(2)	1,555(1)/ 722(2)	
Capacity control	Method	Stepless													
	Minimum capacity	%	12.5												
Power input	Cooling	Nom.	kW	257(1)/ 74.3(2)	272(1)/ 87.9(2)	293(1)/ 90.7(2)	324(1)/ 99.8(2)	360(1)/ 109(2)	399(1)/ 118(2)	397(1)/ 131(2)	439(1)/ 143(2)	454(1)/ 152(2)	492(1)/ 160(2)	530(1)/ 170(2)	
EER				2.49(1)/ 8.62(2)	2.84(1)/ 8.78(2)	2.90(1)/ 9.4(2)	2.78(1)/ 9.04(2)	2.85(1)/ 9.43(2)	2.73(1)/ 9.19(2)	3.19(1)/ 9.67(2)	3.08(1)/ 9.45(2)	3.16(1)/ 9.42(2)	3.04(1)/ 9.33(2)	2.93(1)/ 9.16(2)	
ESEER				3.44	3.52	3.78	3.50	3.74	3.54	3.88	3.78	4.01	3.95	3.85	
IPLV				3.87	4.03	4.07	4.05	4.00	3.93	4.36	4.25	4.36	4.35	4.24	
Casing	Colour	Ivory white													
	Material	Galvanized and painted steel sheet													
Dimensions	Unit	Height	mm	2,565											
		Width	mm	2,480											
		Depth	mm	6,185	7,085	7,985	8,885	10,685							
Weight	Unit	kg	8,050	8,620	9,190	10,450	10,710	12,190	12,830	12,910	12,960				
	Operation weight	kg	8,320	8,870	9,430	10,850	11,110	12,580	13,820	13,900	13,950				
Water heat exchanger	Type	Single pass shell & tube													
	Water volume	l	266	251	243	403	386	979							
	Nominal water flow	Cooling	l/s	27.8	33.5	37.0	39.2	44.6	47.3	55.1	58.6	62.4	64.9	67.6	
	Nominal water pressure drop	Cooling	Heat exchanger	kPa	85 / 128(2)	105 / 172(2)	90 / 178(2)	101 / 198(2)	111 / 245(2)	124 / 272(2)	98 / 232(2)	110 / 259(2)	139 / 305(2)	150 / 328(2)	162 / 354(2)
	Insulation material	Closed cell													
Air heat exchanger	Type	High efficiency fin and tube type with integral subcooler													
Fan	Quantity	10	12	14	16	20									
	Type	Direct propeller													
	Diameter	mm	800												
	Air flow rate	Nom.	l/s	50,367	60,440	70,513	80,587	95,253							
	Speed	rpm	920												
Fan motor	Drive	Inverter													
	Input	Cooling	W	5,200	6,300	6,800	7,300	8,400	9,200	14,100	18,100	10,800	18,100	12,700	
Sound power level	Cooling	Nom.	dBA	96.0	96.8	97.4	98.0	98.2	98.8	98.9					
Sound pressure level	Cooling	Nom.	dBA	75.5(1)	76.3(1)	76.5(1)	76.9(1)	77.1(1)	76.7(1)	76.8(1)					
Compressor	Type	Asymm single screw													
	Quantity	2													
	Oil	Charged volume	l	38			44	50							
Operation range	Water side	Cooling	Min.	°CDB	-8										
			Max.	°CDB	15										
	Air side	Cooling	Min.	°CDB	-20										
			Max.	°CDB	45										
Refrigerant	Type	R-134a													
	Charge	kg	128	146	162	182	214	225	248						
	Circuits	Quantity	2												
Piping connections	Evaporator water inlet/outlet (OD)	DN150PN16(168.3mm)				DN200PN16(219.1mm)				DN250PN16(273mm)					
Mechanical capacity	kW	345(2)	407(2)	439(2)	468(2)	524(2)	565(2)	675(2)	697(2)	772(2)	834(2)				
Air temperature for free cooling 100%	°C	-0.8	-0.1	1.2	0.4	0.9	0.1	2.9	2.1	1.3	0.7	0.1			

2
2

2 Specifications

2-2 Electrical Specifications				EWAD 640CFXL	EWAD 770CFXL	EWAD 850CFXL	EWAD 900CFXL	EWAD C10CFXL	EWAD C11CFXL	EWAD C12CFXL	EWAD C13CFXL	EWAD C14CFXL	EWAD C15CFXL	EWAD C16CFXL
Compressor	Phase			3~										
	Voltage			V										
	Voltage range	Min.	%	-10										
		Max.	%	10										
	Maximum running current			A	218	231	274	333	398	451				
Starting method			Wye-delta											
Compressor 2	Maximum running current			A	218	231	274	333	398	451				
Power supply	Phase			3~										
	Frequency			Hz										
	Voltage			V										
	Voltage range	Min.	%	-10										
		Max.	%	10										
Unit	Maximum starting current			A	605	619	658	924	971	1,030	1,073	1,086		
	Nominal running current (RLA)	Cooling	A	404	430	467	515	568	628	636	701	720	773	825
			A	476	510	561	605	672	731	811	875	929	982	
	Max unit current for wires sizing			A	520	556	612	660	733	797	884	955	1,013	1,072
Fans	Nominal running current (RLA)			A	40	48	56	64	80					

Notes

- (1) Cooling: evaporator 16/10°C, ambient 35°C, unit at full load operation; standard: ISO 3744
- (2) Data is calculated at ambient air temperature 5°C, inlet water temperature 16°C.
- (3) Fluid: water + ethylene glycol 30%
- (4) Allowed voltage tolerance ± 10%. Voltage unbalance between phases must be within ± 3%.
- (5) Maximum starting current: starting current of biggest compressor + 75 % of maximum current of the other compressor + fans current for the circuit at 75 %
- (6) Nominal current in cooling mode: entering evaporator water temp. 12°C; leaving evaporator water temp. 7°C; ambient air temp. 35°C. Compressor + fans current.
- (7) Maximum running current is based on max compressor absorbed current in its envelope and max fans absorbed current
- (8) Maximum unit current for wires sizing is based on minimum allowed voltage.
- (9) Maximum current for wires sizing: (compressors full load ampere + fans current) x 1.1

3 Features and advantages

3 - 1 Features and Advantages

Low operating cost and extended operating life

This chiller range is the result of careful design, aimed to optimize the energy efficiency of the chillers, with the objective of bringing down operating costs and improving installation profitability, effectiveness and economical management.

The chillers feature a high efficiency single screw compressor design, large condenser coil surface area for maximum heat transfer and low discharge pressure, advanced technology condenser fans and a 'shell&tube' evaporator with low refrigerant pressure drops.

The free cooling chillers make use of an additional free cooling section to cool the building water loop directly with the outside ambient air, thus reducing the load on the compressors and considerably decreasing operating costs during the cold season. Free cooling takes advantage of the temperature difference between the outside air and the return water to cool the water before returning it at a lower temperature to be chilled. And when outside temperatures are cold enough the chillers compressors are fully shut down and cooling is practically free. Moreover, cutting compressor usage also extends the chiller's operating life, further minimizing the overall cost of an installation.

Low operating sound levels

Very low sound levels both at full load and part load conditions are achieved by the latest compressor design and by a unique new fan that moves large volume of air at exceptionally low sound levels and by the virtually vibration-free operation.

Outstanding reliability

The chillers have two truly independent refrigerant circuits, in order to assure maximum safety for any maintenance, whether planned or not. They are equipped with a rugged compressor design with advanced composite compressor gaterotors material, a proactive control logic and are full factory-run-tested to optimized trouble-free operation.

Infinite capacity control

Cooling capacity control is infinitely variable by means of a single screw asymmetric compressor controlled by microprocessor system. Each unit has infinitely variable capacity control from 100% down to 12.5%. This modulation allows the compressor capacity to exactly match the building cooling load without any leaving evaporator water temperature fluctuation. This chilled water temperature fluctuation is avoided with a stepless control.

With a compressor load step control in fact, the compressor capacity, at partial loads, will be too high or too low compared to the building cooling load. The result is an increase in chiller energy costs, particularly at the part-load conditions at which the chiller operates most of the time.

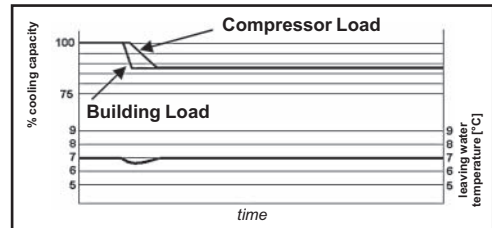

ELWT fluctuation with steps capacity control

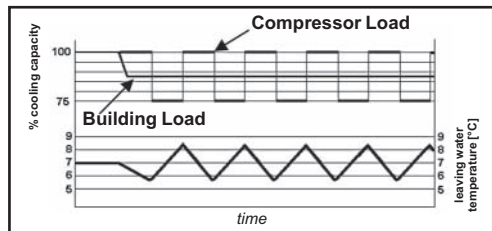

ELWT fluctuation with steps capacity control (4 steps)

Units with stepless regulation offer benefits that the units with step regulation are unable to match. The ability to follow the system energy demand at any time and the possibility to provide steady outlet water temperature without deviations from the set-point, are the two points that allow you to understand how the optimum operating conditions of a system can be met through the use of a unit with stepless regulation.

3 Features and advantages

3 - 1 Features and Advantages

Superior control logic

The new MicroTech III controller provides an easy to use control environment. The control logic is designed to provide maximum efficiency, to continue operation in unusual operating conditions and to provide a history of unit operation. One of the greatest benefits is the easy interface with LonWorks, Bacnet, Ethernet TCP/IP or Modbus communications.

Code requirements – Safety and observant of laws/directives

The range is designed and manufactured in accordance with applicable selections of the following:

Construction of pressure vessel	97/23/EC (PED)
Machinery Directive	2006/42/EC
Low Voltage	2006/95/EC
Electromagnetic Compatibility	2004/108/EC
Electrical & Safety codes	EN 60204–1 / EN 60335-2-40
Manufacturing Quality Stds	UNI – EN ISO 9001:2004

Certifications

All units manufactured by Daikin are CE marked, complying with European directives in force, concerning manufacturing and safety. On request units can be produced complying with laws in force in non European countries (ASME, GOST, etc.), and for other applications, such as naval (RINA, etc.).

Versions

The range is available in three versions:

X: High efficiency

11 sizes to cover a range from 640 up to 1555 kW with an EER up to 3.19 and an ESEER up to 4.01 (data referred to Standard Noise)

The EER (Energy Efficiency Ratio) is the ratio of the Cooling Capacity to the Power Input of the unit. The Power Input includes: the power input for operation of the compressor, the power input of all control and safety devices, the power input for fans.

The ESEER (European Seasonal Energy Efficiency Ratio) is a weighed formula enabling to take into account the variation of EER with the load rate and the variation of air inlet condenser temperature.

$$ESEER = A \times EER_{100\%} + B \times EER_{75\%} + C \times EER_{50\%} + D \times EER_{25\%}$$

	A	B	C	D
Coefficient	0.03 (3%)	0.33 (33%)	0.41 (41%)	0.23 (23%)
Air inlet condenser temperature	35°C	30°C	25°C	20°C

Sound configurations

The range is available in three versions:

S: Standard Sound

Condenser fan rotating at 920 rpm, rubber antivibration under compressor

L: Low Sound

Condenser fan rotating at 920 rpm, rubber antivibration under compressor, compressor sound enclosure.

X: Reduced Sound

Condenser fan rotating at 715 rpm, rubber antivibration under compressor, compressor sound enclosure.

4 General Characteristics

4 - 1 General characteristics

Cabinet and structure

The cabinet is made of galvanized steel sheet and painted to provide a high resistance to corrosion. Colour Ivory White (Munsell code 5Y7.5/1) (\pm RAL7044). The base frame has an eye-hook to lift the unit with ropes for an easy installation. The weight is uniformly distributed along the profiles of the base and this facilitates the arrangement of the unit.

Compressor (Asymmetric Single Screw)

The compressor is semi-hermetic, single-screw type with gate-rotor made with the latest high-strength fibre reinforced star material. The compressor has an asymmetric slide regulation managed by the unit controller for infinitely modulating capacity from 100% to 25%. An integrated high efficiency oil separator maximizes the oil separation and standard start is Wye-delta (Y- Δ) type.

Refrigerant

The compressors have been designed to operate with R-134a, ecological refrigerant with zero ODP (Ozone Depletion Potential) and very low GWP (Global Warming Potential), resulting in low TEWI (Total Equivalent Warming Impact).

Evaporator (Shell&Tube)

The unit is equipped with a direct expansion shell&tube evaporator with copper tubes rolled into steel tubesheets. The evaporators are single-pass on both the refrigerant and water sides for pure counter-flow heat exchange and low refrigerant pressure drops. Both attributes contribute to the heat exchanger effectiveness and total unit's outstanding efficiency.

The external shell is covered with a 20mm closed cell insulation material and the evaporator water outlet connections are provided with flange kit (as standard). Each evaporator has 2 circuits, one for each compressor and is manufactured in accordance to PED approval.

Condenser (Air – Refrigerant heat exchanger)

The condenser is manufactured with internally enhanced seamless copper tubes arranged in a staggered row pattern and mechanically expanded into lanced and rippled aluminum condenser fins with full fin collars. An integral sub-cooler circuit provides sub-cooling to effectively eliminate liquid flashing and increase cooling capacity without increasing the power input.

Free Cooling (Air – Water heat exchanger)

The Free Cooling heat exchanger is manufactured with internally enhanced seamless copper tubes arranged in a staggered row pattern and mechanically expanded into lanced and rippled aluminum condenser fins with full fin collars.

Condenser fans (\varnothing 800)

The condenser fans are propeller type with high efficiency design blades to maximize performances. The material of the blades is glass reinforced resin and each fan is protected by a guard. Fan motors are protected by circuit breakers (installed inside the electrical panel as a standard) and are IP54. Fan speed regulation is standard available (Option 99).

Electronic expansion valve

The unit is equipped with the most advanced electronic expansion valves to achieve precise control of refrigerant mass flow. As today's system requires improved energy efficiency, tighter temperature control, wider range of operating conditions and incorporate features like remote monitoring and diagnostics, the application of electronic expansion valves becomes mandatory. Electronic expansion valves possess unique features: short opening and closing time, high resolution, positive shut-off function to eliminate use of additional solenoid valve, continuous modulation of mass flow without stress in the refrigerant circuit and corrosion resistance stainless steel body. Electronic expansion valves are typically working with lower ΔP between high and low pressure side, than a thermostatic expansion valve. The electronic expansion valve allows the system to work with low condenser pressure (winter time) without any refrigerant flow problems and with a perfect chilled water leaving temperature control.

Refrigerant circuit

Each unit has 2 independent refrigerant circuits and each one includes:

- Compressor with integrated oil separator
- Air Cooled Condenser
- Electronic expansion valve
- Evaporator
- Discharge line shut off valve
- Liquid line shut off valve
- Suction line shut off valve (optional)
- Sight glass with moisture indicator
- Filter drier
- Charging valves
- High pressure switch
- High and low pressure transducers

GNC_1-2-3-4_Rev.00_1

4 General Characteristics

4 - 1 General characteristics

Free Cooling Water Circuit

“Standard Glycol” Free Cooling

The principal hydraulic circuit is connected directly (through a three way valve) with the free cooling section, creating a circuit with a water-glycol mixture. The free cooling section includes:

- Air-water heat exchanger
- Three way valve (as standard)

Electrical control panel

Power and control are located in the main panel that is manufactured to ensure protection against all weather conditions. The electrical panel is IP54 and (when opening the doors) internally protected with plexiglas panel against possible accidental contact with electrical components (IP20). The main panel is fitted with a main switch interlocked door.

Power Section

The power section includes compressors fuses, fan circuit breaker, fan contactors and control circuit transformer.

MicroTech III controller

MicroTech III controller is installed as standard; it can be used to modify unit set-points and check control parameters. A built-in display shows chiller operating status plus temperatures and pressures of water, refrigerant and air, programmable values, set-points. A sophisticated software with predictive logic, selects the most energy efficient combination of compressors, EEXV and condenser fans to keep stable operating conditions to maximise chiller energy efficiency and reliability.

MicroTech III is able to protect critical components based on external signs from its system (such as motor temperatures, refrigerant gas and oil pressures, correct phase sequence, pressure switches and evaporator). The input coming from the high pressure switch cuts all digital output from the controller in less than 50ms, this is an additional security for the equipment. Fast program cycle (200ms) for a precise monitoring of the system. Floating point calculations supported for increased accuracy in P/T conversions.

Control section - main features

- Management of the compressor stepless capacity and fans modulation.
- Chiller enabled to work in partial failure condition.
- Full routine operation at condition of:
 - high ambient temperature value
 - high thermal load
 - high evaporator entering water temperature (start-up)
- Display of evaporator entering/leaving water temperature.
- Display of Outdoor Ambient Temperature.
- Display of condensing-evaporating temperature and pressure, suction and discharge superheat for each circuit.
- Leaving water evaporator temperature regulation (temperature tolerance = 0,1°C).
- Compressor and evaporator pumps hours counter.
- Display of Status Safety Devices.
- Number of starts and compressor working hours.
- Optimized management of compressor load.
- Fan management according to condensing pressure.
- Re-start in case of power failure (automatic / manual).
- Soft Load (optimized management of the compressor load during the start-up).
- Start at high evaporator water temperature.
- Return Reset (Set Point Reset based on return water temperature).
- OAT (Outside Ambient temperature) Reset.
- Set point Reset (optional).
- Application and system upgrade with commercial SD cards.
- Ethernet port for remote or local servicing using standard web browsers.
- Two different sets of default parameters could be stored for easy restore.

Safety device / logic for each refrigerant circuit

- High pressure (pressure switch).
- High pressure (transducer).
- Low pressure (transducer).
- Fans circuit breaker.
- High compressor discharge temperature.
- High motor winding temperature.
- Phase Monitor.
- Low pressure ratio.
- High oil pressure drop.
- Low oil pressure.
- No pressure change at start.

GNC_1-2-3-4_Rev.00_2

4 General Characteristics

4 - 1 General characteristics

System security

- Phase monitor.
- Low Ambient temperature lock-out.
- Freeze protection.

Regulation type

Proportional + integral + derivative regulation on the evaporator leaving water output probe.

MicroTech III

MicroTech III built-in terminal has the following features.

- 164x44 dots liquid crystal display with white back lighting. Supports Unicode fonts for multi-lingual.
- Key-pad consisting of 3 keys.
- Push'n'Roll control for an increased usability.
- Memory to protect the data.
- General faults alarm relays.
- Password access to modify the setting.
- Application security to prevent application tampering or hardware usability with third party applications.
- Service report displaying all running hours and general conditions.
- Alarm history memory to allow an easy fault analysis.

Supervising systems (on request)

MicroTech III remote control

MicroTech III is able to communicate to BMS (Building Management System) based on the most common protocols as:

- ModbusRTU
- LonWorks, now also based on the international 8040 Standard Chiller Profile and LonMark Technology.
- BacNet BTP certified over IP and MS/TP (class 4) (Native).
- Ethernet TCP/IP.

Standard Options (supplied on basic unit)

Wye-Delta compressor starter (Y-D) - For low inrush current and reduced starting torque

Double setpoint - Dual leaving water temperature setpoints.

Phase monitor - The phase monitor controls that phases sequence is correct and controls phase loss.

Evaporator flange kit

20mm evaporator insulation - The external shell is covered with a 20mm closed cell insulation material.

Evaporator electric heater - Electric heater (controlled by a thermostat) to protect the evaporator from freezing down to -28°C ambient temperature, providing the power supply is on.

Electronic expansion valve

Discharge line shut-off valve - Installed on the discharge port of the compressor to facilitate maintenance operation.

Ambient outside temperature sensor and setpoint reset

Hour run meter

General fault contactor

Setpoint reset, Demand limit and Alarm from external device - (Set-point reset): The leaving water temperature set-point can be overwritten with the following options: 4-20mA from external source (by user); outside ambient temperature; evaporator water temperature Δt . - (Demand limit): User can limit the load of the unit by 4-20mA signal or by network system. - (Alarm from external device): Microprocessor is able to receive an alarm signal from an external device (eg. pump, etc...). User can decide if this alarm signal will stop or not the unit.

Fans circuit breakers - Safety device against motor overloading and short circuit.

Main switch interlock door

Emergency stop

Fans speed regulation (+ fan silent mode) - To control the fan speed revolution for smooth operating control of the unit. This option improves the sound level of the unit during low ambient temperature operation.

Options (on request)

Soft starter - Electronic starting device to reduce the mechanical stress during compressor start-up

Brine version - Allows the unit to operate down to -8°C leaving liquid temperature (antifreeze required).

Compressor thermal overload relays - Safety devices against compressor motor overloading. This device together with internal motor protection (standard) guarantee the best safety system for compressor motor.

Under / Over voltage control - This device control the voltage value of power supply and stop the chiller if the value exceeds the allowed operating limits.

Energy meter - Device installed inside the control box showing ampere and volt values

GNC_1-2-3-4_Rev.00_3

4 General Characteristics

4 - 1 General characteristics

2

4

Capacitors for power factor correction - To increase the operating power factor of the unit at nominal operating conditions. The capacitors are “dry” self-regenerating type with over pressure disconnecting safety device insulated with a no toxic dielectric mix with no PCB or PCT.

Current limit - To limit maximum absorbed current of the unit whenever is required

Condenser coil guards

Evaporator area guards

Cu-Cu condenser coil - To give better protection against corrosion by aggressive environments.

Cu-Cu-Sn condenser coil - To give better protection against corrosion in aggressive environments and by salty air.

Alucoat fins coil - Fins are protected by a special acrylic paint with a high resistance to corrosion.

Evaporator flow switch - Supplied separately to be wired and installed on the evaporator water piping (by the customer).

Suction line shut-off valve - Installed on the suction port of the compressor to facilitate maintenance operation.

High pressure side manometers

Low pressure side manometers

Rubber anti vibration mounts - Supplied separately, these are positioned under the base of the unit during installation. Ideal to reduce the vibrations when the unit is floor mounted.

Spring anti vibration mounts - Supplied separately, these are positioned under the base of the unit during installation. Ideal for dampening vibrations for installation on roofs and metallic structures.

One centrifugal pump (low lift) - Hydronic kit consists of: single direct driven centrifugal pump, water filling system with pressure gauge, safety valve, drain valve. The motor pump is protected by a circuit breaker installed in control panel. The kit is assembled and wired to the control panel. The pipe and pump are protected from freezing with an additional electrical heater.

One centrifugal pump (high lift) - Hydronic kit consists of: single direct driven centrifugal pump, water filling system with pressure gauge, safety valve, drain valve. The motor pump is protected by a circuit breaker installed in control panel. The kit is assembled and wired to the control panel. The pipe and pump are protected from freezing with an additional electrical heater.

Two centrifugal pump (low lift) - Hydronic kit consists of: twin direct driven centrifugal pumps, water filling system with pressure gauge, safety valve, drain valve. The motor pump is protected by a circuit breaker installed in control panel. The kit is assembled and wired to the control panel. The pipe and pumps are protected from freezing with an additional electrical heater.

Two centrifugal pump (high lift) - Hydronic kit consists of: twin direct driven centrifugal pumps, water filling system with pressure gauge, safety valve, drain valve. The motor pump is protected by a circuit breaker installed in control panel. The kit is assembled and wired to the control panel. The pipe and pumps are protected from freezing with an additional electrical heater.

Double pressure relief valve with diverter

Compressors circuit breakers

Evaporator right water connections

Ground fault relay - To shut down the entire unit if a ground fault condition is detected.

Rapid restart - It allows the unit to start as fast as 30 seconds after power is restored (in case of power failure).

Transport kit

Optimized free cooling (VFD fans regulation) - This option allows the unit having better performances (better efficiency) in the range of temperatures between Starting Free Cooling (starting free cooling is when the outside temperature is one degree below entering water temperature at the free cooling unit) and Free Cooling 100% (free cooling 100% is when the total load of the installation is satisfied by the free cooling).

Optimized free cooling (On/Off fans) - This option allows the unit having better performances (better efficiency) in the range of temperatures between Starting Free Cooling (starting free cooling is when the outside temperature is one degree below entering water temperature at the free cooling unit) and Free Cooling 100% (free cooling 100% is when the total load of the installation is satisfied by the free cooling).

5 Nomenclature

5 - 1 Nomenclature

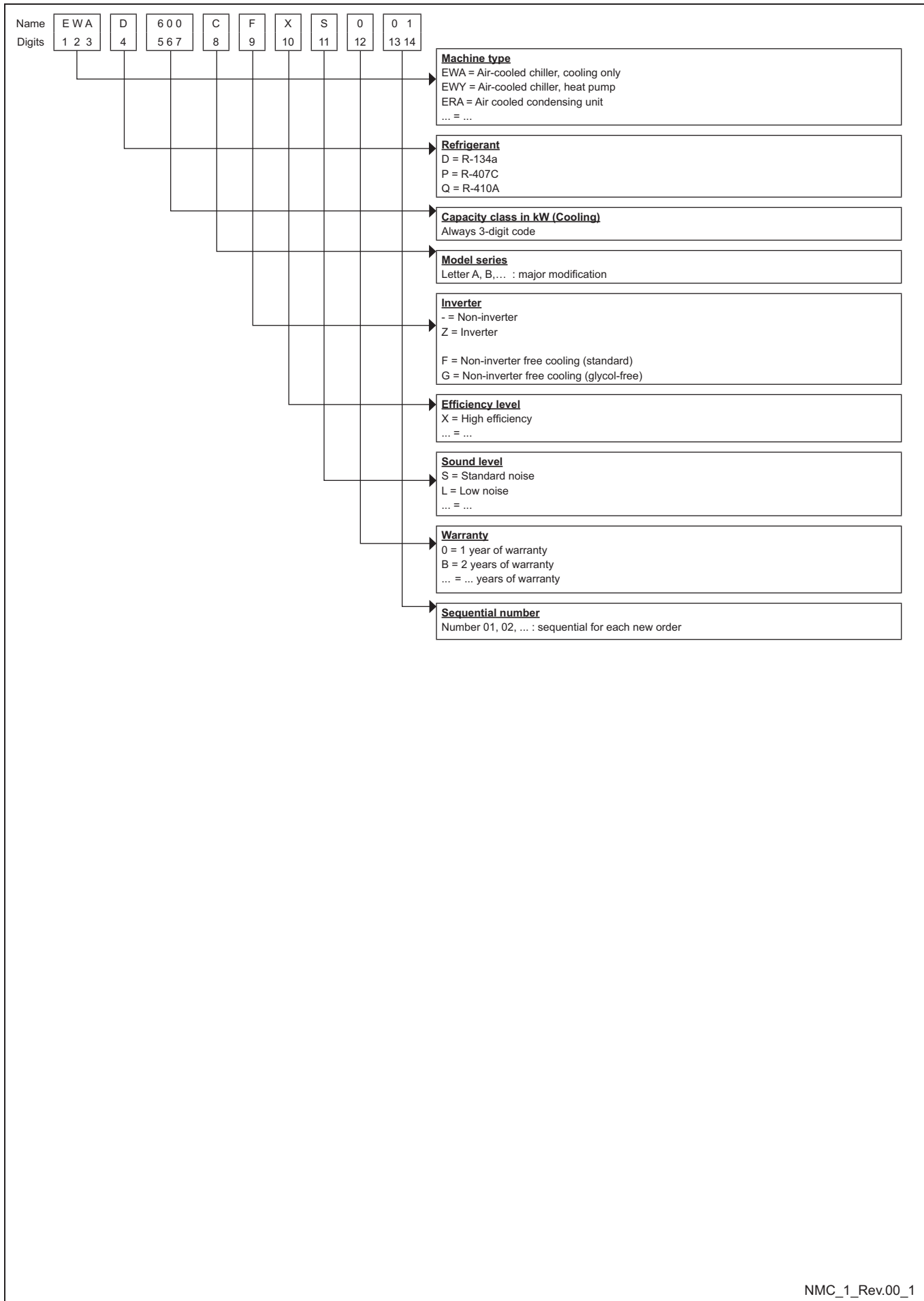

2
5

6 Capacity tables

6 - 1 Cooling Capacity Tables

2
6

EWAD-CFXL Cooling performance													
	Twout	8				9				10			
		Ta	CC	PI	qw	dpw	CC	PI	qw	dpw	CC	PI	qw
		kW	kW	l/s	kPa	kW	kW	l/s	kPa	kW	kW	l/s	kPa
640	25	682	216	29,7	96	700	219	30,4	100	717	223	31,2	105
	30	648	232	28,2	87	664	236	28,9	91	681	240	29,6	95
	32	632	238	27,5	83	649	242	28,2	87	665	247	28,9	91
	35	608	248	26,4	77	624	253	27,1	81	640	257	27,8	85
	38	582	259	25,3	71	597	264	26,0	75	613	269	26,6	78
770	25	563	267	24,5	67	578	271	25,1	71	593	276	25,8	74
	30	789	224	34,3	110	809	228	35,2	115	829	232	36,0	120
	32	765	243	33,3	104	785	247	34,1	108	804	251	34,9	113
	35	754	251	32,8	101	773	255	33,6	105	792	259	34,4	110
	38	712	276	31,0	91	730	281	31,8	95	748	285	32,5	99
850	40	695	285	30,2	87	713	290	31,0	91	731	295	31,7	95
	25	866	242	37,7	94	888	246	38,6	98	910	250	39,6	102
	30	842	263	36,6	89	863	267	37,5	93	884	271	38,4	97
	32	831	271	36,1	87	851	275	37,0	91	872	279	37,9	95
	35	812	285	35,3	83	832	289	36,2	87	852	293	37,0	90
900	38	788	299	34,3	79	809	303	35,1	82	828	308	36,0	86
	40	770	308	33,5	75	790	313	34,4	79	810	318	35,2	82
	25	922	267	40,1	105	943	271	41,0	110	965	275	41,9	114
	30	896	290	39,0	100	916	294	39,8	104	937	299	40,7	108
	32	883	300	38,4	97	904	304	39,3	101	924	309	40,2	105
C10	35	863	315	37,5	93	882	320	38,3	97	902	324	39,2	101
	38	835	331	36,3	88	857	336	37,2	92	876	341	38,1	95
	40	815	341	35,4	84	835	347	36,3	87	856	353	37,2	91
	25	1052	297	45,7	117	1080	302	46,9	123	1108	307	48,1	128
	30	1018	322	44,3	110	1045	327	45,4	115	1072	333	46,6	121
C11	32	1002	332	43,6	107	1029	338	44,7	112	1055	343	45,8	117
	35	976	348	42,4	102	1001	354	43,5	106	1027	360	44,6	111
	38	945	365	41,1	96	969	371	42,1	100	994	377	43,2	105
	40	922	377	40,1	91	945	383	41,1	96	963	386	41,9	99
	25	1123	329	48,9	132	1152	335	50,1	139	1180	340	51,3	145
C12	30	1085	356	47,2	124	1113	362	48,4	130	1140	369	49,5	136
	32	1068	368	46,4	120	1094	374	47,6	126	1121	380	48,7	131
	35	1037	386	45,1	114	1063	393	46,2	119	1089	399	47,3	124
	38	1001	405	43,5	107	1026	412	44,6	112	1052	419	45,7	117
	40	974	418	42,4	101	999	425	43,4	106	1011	426	43,9	108
C13	25	1277	328	55,5	100	1311	332	57,0	105	1345	337	58,4	110
	30	1244	356	54,1	95	1277	361	55,5	100	1310	367	56,9	104
	32	1229	368	53,5	93	1262	373	54,9	97	1295	379	56,3	102
	35	1205	386	52,4	89	1237	392	53,8	94	1269	397	55,1	98
	38	1176	405	51,2	85	1207	411	52,5	90	1239	417	53,8	94
C14	40	1155	418	50,2	82	1185	424	51,5	87	1216	430	52,8	91
	25	1363	362	59,3	113	1398	367	60,8	118	1434	372	62,3	124
	30	1327	393	57,7	107	1361	399	59,2	112	1396	404	60,7	118
	32	1311	406	57,0	105	1345	412	58,4	110	1379	418	59,9	115
	35	1283	426	55,8	101	1316	432	57,2	105	1349	439	58,6	110
C15	38	1251	447	54,4	96	1283	454	55,8	101	1315	460	57,2	105
	40	1227	462	53,4	93	1258	469	54,7	97	1290	476	56,0	101
	25	1457	375	63,3	143	1498	381	65,1	151	1540	388	66,9	158
	30	1413	406	61,4	135	1453	413	63,1	142	1493	420	64,9	149
	32	1393	419	60,6	132	1432	426	62,2	138	1471	433	63,9	145
C16	35	1360	440	59,1	126	1397	447	60,7	132	1435	454	62,4	139
	38	1321	461	57,5	119	1358	468	59,0	125	1394	476	60,6	131
	40	1293	475	56,2	114	1328	483	57,7	120	1364	491	59,3	126
	25	1522	404	66,2	156	1562	410	67,9	163	1602	417	69,6	171
	30	1476	439	64,2	147	1515	446	65,9	154	1554	453	67,5	161
C16	32	1455	454	63,3	143	1493	461	64,9	150	1532	468	66,5	157
	35	1419	476	61,7	136	1456	484	63,3	143	1493	492	64,9	150
	38	1377	500	59,9	129	1413	508	61,4	135	1450	517	63,0	142
	40	1345	517	58,5	123	1381	525	60,0	129	1416	534	61,5	136
	25	1591	433	69,2	169	1632	440	71,0	177	1674	447	72,7	185
C16	30	1542	472	67,1	160	1581	479	68,7	167	1621	487	70,4	175
	32	1520	488	66,1	155	1558	496	67,7	162	1596	504	69,4	170
	35	1481	514	64,4	148	1518	522	66,0	155	1555	530	67,6	162
	38	1434	540	62,4	139	1471	549	64,0	146	1508	558	65,5	152
	40	1399	559	60,9	133	1435	568	62,4	139	1472	577	64,0	146

Fluid: Water + Ethylene Glycol 30%
 Ta: Condenser inlet air temperature; Twout: Evaporator leaving water temperature (Δt6°C)
 CC: Cooling capacity; PI: Power input; qw: Fluid flow rate; dpw: Fluid pressure drop
 * For working condition where dpw value is "Italic-Red Color" please contact factory

6 Capacity tables

6 - 1 Cooling Capacity Tables

EWAD-CFXL Cooling performance													
	Twout	11				12				13			
		Ta	CC	PI	qw	dpw	CC	PI	qw	dpw	CC	PI	qw
		kW	kW	l/s	kPa	kW	kW	l/s	kPa	kW	kW	l/s	kPa
640	25	735	227	31,9	109	753	231	32,7	114	772	235	33,5	119
	30	698	244	30,3	99	715	248	31,0	104	732	253	31,8	108
	32	682	251	29,6	95	699	255	30,3	99	715	260	31,0	104
	35	656	262	28,5	89	672	267	29,2	93	688	271	29,9	97
	38	628	273	27,3	82	644	278	28,0	86	660	283	28,6	89
770	25	849	281	36,4	125	870	239	37,8	131	890	243	38,6	136
	30	823	255	35,8	118	843	259	36,6	123	862	263	37,4	128
	32	811	263	35,2	115	830	267	36,0	120	849	272	36,9	125
	35	790	276	34,3	110	809	281	35,1	114	827	285	35,9	119
	38	766	290	33,3	103	784	294	34,0	108	802	299	34,8	112
850	25	932	253	40,5	107	953	257	41,4	111	974	261	42,3	116
	30	906	275	39,3	101	927	279	40,2	106	947	283	41,1	110
	32	893	284	38,8	99	914	288	39,7	103	935	292	40,6	107
	35	872	298	37,9	94	893	302	38,8	98	913	307	39,6	103
	38	848	312	36,8	90	868	317	37,7	93	888	322	38,5	97
900	25	986	279	42,8	119	1008	283	43,8	124	1030	288	44,7	128
	30	958	303	41,6	112	979	308	42,5	117	1000	312	43,4	121
	32	944	313	41,0	110	965	318	41,9	114	986	322	42,8	118
	35	922	329	40,0	105	941	334	40,9	109	961	339	41,7	113
	38	895	346	38,9	99	914	351	39,7	103	934	356	40,5	107
C10	25	1136	312	49,3	134	1164	318	50,5	140	1192	323	51,7	147
	30	1099	338	47,7	126	1126	344	48,9	132	1153	349	50,0	138
	32	1082	349	47,0	123	1108	355	48,1	128	1135	361	49,2	134
	35	1052	366	45,7	116	1078	372	46,8	122	1104	378	47,9	127
	38	1019	383	44,2	110	1043	390	45,3	114	1062	393	46,1	118
C11	25	1209	346	52,5	151	1238	352	53,7	158	1267	358	55,0	165
	30	1167	375	50,7	142	1195	381	51,9	148	1222	388	53,0	154
	32	1148	387	49,9	137	1175	393	51,0	143	1201	400	52,1	149
	35	1114	406	48,4	130	1140	413	49,5	135	1166	420	50,6	141
	38	1076	426	46,8	122	1101	433	47,8	127	1113	433	48,3	129
C12	25	1380	342	59,9	115	1415	347	61,4	120	1450	352	62,9	126
	30	1344	372	58,4	109	1378	377	59,8	114	1412	383	61,3	120
	32	1328	384	57,7	107	1361	390	59,1	112	1395	395	60,5	117
	35	1301	403	56,5	103	1334	409	57,9	108	1367	415	59,3	112
	38	1270	423	55,2	98	1302	429	56,5	103	1334	435	57,9	107
C13	25	1470	378	63,9	130	1507	384	65,4	135	1544	389	67,0	142
	30	1431	410	62,2	123	1466	417	63,7	129	1502	423	65,2	134
	32	1413	424	61,4	120	1448	430	62,9	126	1483	437	64,4	131
	35	1383	445	60,1	115	1417	452	61,5	121	1451	458	63,0	126
	38	1348	467	58,5	110	1381	474	59,9	115	1414	481	61,3	120
C14	25	1581	394	68,7	166	1623	401	70,5	174	1665	408	72,3	183
	30	1533	427	66,6	157	1573	434	68,3	164	1614	442	70,0	172
	32	1511	441	65,6	153	1551	448	67,3	160	1591	456	69,0	168
	35	1474	462	64,0	146	1513	469	65,7	153	1552	477	67,3	160
	38	1431	484	62,2	138	1469	492	63,8	144	1506	500	65,4	151
C15	25	1715	454	74,5	194	1758	462	76,3	203	1800	469	78,1	212
	30	1661	495	72,1	182	1701	503	73,8	190	1741	511	75,6	199
	32	1635	512	71,0	177	1675	520	72,7	185	1714	529	74,4	193
	35	1593	539	69,2	169	1630	547	70,8	176	1668	556	72,4	183
	38	1544	567	67,1	159	1580	576	68,6	166	1617	585	70,2	173
C16	40	1508	586	65,5	152	1543	596	67,0	159	1550	590	67,3	160

Fluid: Water + Ethylene Glycol 30%

Ta: Condenser inlet air temperature; Twout: Evaporator leaving water temperature (Δt 6°C)

CC: Cooling capacity; PI: Power input; qw: Fluid flow rate; dpw: Fluid pressure drop

* For working condition where dpw value is "Italic-Red Color" please contact factory

6 Capacity tables

6 - 1 Cooling Capacity Tables

EWAD-CFXL
Free cooling performance

Twout	8					9					10				
	TFC °C	CC kW	PI kW	qw l/s	dpw kPa	TFC °C	CC kW	PI kW	qw l/s	dpw kPa	TFC °C	CC kW	PI kW	qw l/s	dpw kPa
640	-2,1	608	19,1	26,4	117	-1,5	624	19	27,1	123	-0,8	640	19,1	27,8	128
770	-1,4	735	22,7	32	158	-0,8	753	22,6	32,7	165	-0,1	772	22,6	33,5	172
850	-0,2	812	26,2	35,3	164	0,5	832	26,2	36,2	171	1,2	852	26,3	37	178
900	-1,0	863	26,2	37,5	183	-0,3	882	26,2	38,3	190	0,4	902	26,2	39,2	198
C10	-0,4	976	29,9	42,4	224	0,2	1001	29,7	43,5	234	0,9	1027	29,8	44,6	245
C11	-1,2	1037	30	45,1	250	-0,6	1063	29,8	46,2	261	0,1	1089	29,9	47,3	272
C12	1,6	1205	37,1	52,4	212	2,2	1237	36,8	53,8	222	2,9	1269	36,8	55,1	232
C13	0,8	1283	37	55,8	238	1,5	1316	37,1	57,2	248	2,1	1349	36,8	58,6	259
C14	0,0	1360	36,8	59,1	278	0,7	1397	37,1	60,7	291	1,3	1435	37	62,4	305
C15	-0,5	1419	37,1	61,7	300	0,1	1456	37	63,3	314	0,7	1493	36,9	64,9	328
C16	-1,2	1481	36,8	64,4	324	-0,5	1518	37	66	339	0,1	1555	36,9	67,6	354

Fluid: Water + Ethylene Glycol 30%

Ta: Outdoor air temperature; Twout: unit leaving water temperature (Δt 6°C)

TFC: Air temperature for Free Cooling 100%; CC: Cooling capacity; PI: Power input; qw: Fluid flow rate; dpw: Fluid pressure drop

6 Capacity tables

6 - 1 Cooling Capacity Tables

EWAD-CFXL
Free cooling performance

Twout	11					12					13				
	TFC °C	CC kW	PI kW	qw l/s	dpw kPa	TFC °C	CC kW	PI kW	qw l/s	dpw kPa	TFC °C	CC kW	PI kW	qw l/s	dpw kPa
640	-0,1	656	19,2	28,5	134	0,5	672	19,1	29,2	140	1,2	688	19,1	29,9	146
770	0,6	790	22,7	34,3	179	1,3	809	22,7	35,1	186	2,0	827	22,8	35,9	194
850	1,9	872	26,3	37,9	186	2,6	893	26,3	38,8	193	3,3	913	26,4	39,6	201
900	1,1	922	26,2	40	205	1,8	941	26,2	40,9	213	2,5	961	26,2	41,7	221
C10	1,5	1052	29,7	45,7	255	2,2	1078	29,8	46,8	267	2,9	1104	29,9	47,9	278
C11	0,7	1114	29,8	48,4	284	1,4	1140	29,9	49,5	295	2,0	1166	29,8	50,6	307
C12	3,6	1301	36,9	56,5	242	4,3	1334	37	57,9	253	5,0	1367	37,1	59,3	264
C13	2,8	1383	37	60,1	271	3,5	1417	37,1	61,5	282	4,1	1451	36,8	63	294
C14	1,9	1474	36,9	64	320	2,5	1513	36,9	65,7	335	3,1	1552	36,8	67,3	350
C15	1,4	1531	37,1	66,5	343	2,0	1569	37	68,1	358	2,6	1606	36,9	69,7	373
C16	0,7	1593	36,8	69,2	369	1,4	1630	37,1	70,8	384	2,0	1668	37	72,4	400

Fluid: Water + Ethylene Glycol 30%

Ta: Outdoor air temperature; Twout: unit leaving water temperature (Δt 6°C)

TFC: Air temperature for Free Cooling 100%; CC: Cooling capacity; PI: Power input; qw: Fluid flow rate; dpw: Fluid pressure drop

7 Dimensional drawings

7 - 1 Dimensional Drawings

EWAD CFX- (Standard Glycol)

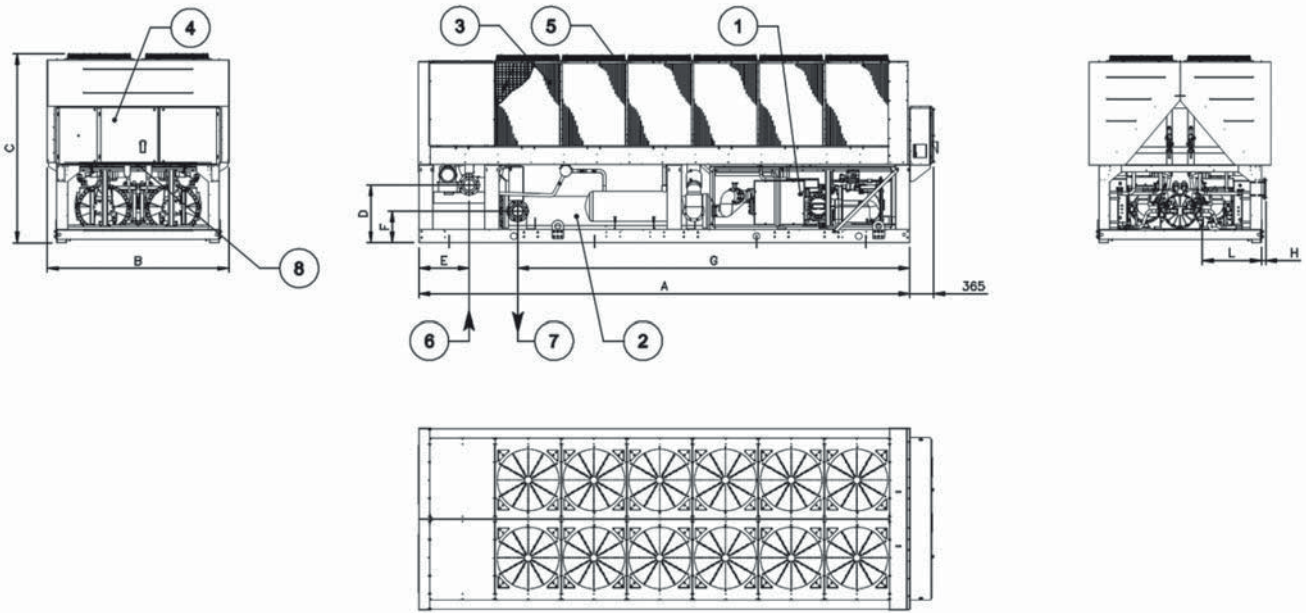

The drawing is for illustration only. Please refer to the table below for unit dimensions.

Models		Dimensions (mm)									
EWAD CFXS/XL	EWAD CFXR	A	B	C	D	E	F	G	H	I	Fans
640	600	5820	2480	2565	795	690	435	5370	75	800	10
770	740	6720	2480	2565	795	690	435	5370	75	800	12
850	820	7620	2480	2565	795	690	435	5370	75	800	14
900	870	7620	2480	2565	795	690	435	5370	75	800	14
C10	980	8520	2480	2565	795	690	540	5355	75	748	16
C11	C10	8520	2480	2565	795	690	540	5355	75	748	16
C12	C11	10320	2480	2565	795	690	540	5355	75	748	20
C13	C12	10320	2480	2565	795	690	540	5355	75	748	20
C14	C13	10320	2480	2565	795	690	540	5355	75	670	20
C15	C14	10320	2480	2565	795	690	540	5355	75	670	20
C16	C15	10320	2480	2565	795	690	540	5355	75	670	20

LEGEND

- 1 – Compressor
- 2 – Evaporator
- 3 – Condenser coil
- 4 – Electrical panel
- 5 – Fan
- 6 – Evaporator water inlet
- 7 – Evaporator water outlet
- 8 – Power connections slot

8 Sound data

8 - 1 Sound Level Data

EWAD-CFXL

MODEL	Sound pressure level at 1 m from the unit (rif. 2 x 10 ⁻⁵ Pa)									Power dB(A)
	63 Hz	125 Hz	250 Hz	500 Hz	1000 Hz	2000 Hz	4000 Hz	8000 Hz	dB(A)	
640	70,4	72,5	75,3	74,5	70,4	65,9	56,3	47,2	75,5	96,0
770	71,2	73,3	76,1	75,3	71,2	66,7	57,1	48,0	76,3	96,8
850	71,4	73,5	76,3	75,5	71,4	66,9	57,3	48,2	76,5	97,4
900	71,4	73,5	76,3	75,5	71,4	66,9	57,3	48,2	76,5	97,4
C10	71,8	73,9	76,7	75,9	71,8	67,3	57,7	48,6	76,9	98,0
C11	72,0	74,1	76,9	76,1	72,0	67,5	57,9	48,8	77,1	98,2
C12	71,6	73,7	76,5	75,7	71,6	67,1	57,5	48,4	76,7	98,8
C13	71,7	73,8	76,6	75,8	71,7	67,2	57,6	48,5	76,8	98,9
C14	71,7	73,8	76,6	75,8	71,7	67,2	57,6	48,5	76,8	98,9
C15	71,7	73,8	76,6	75,8	71,7	67,2	57,6	48,5	76,8	98,9
C16	71,7	73,8	76,6	75,8	71,7	67,2	57,6	48,5	76,8	98,9

NOTES

Fluid: Water + Ethylene Glycol 30%

Note: The values are according to ISO 3744 and are referred to: evaporator 12/7° C, air ambient 35°C, full load operation

NSL_1-2-3_Rev.00_2

9 Installation

9 - 1 Installation Method

Installation notes

Warning

Installation and maintenance of the unit must be performed only by qualified personnel who have knowledge with local codes and regulations, and experience with this type of equipment. Must be avoided the unit installation in places that could be considered dangerous for all the maintenance operations.

Handling

Care should be taken to avoid rough handling or shock due to dropping the unit. Do not push or pull the unit from anything other than the base frame. Never allow the unit to fall during unloading or moving as this may result in serious damage. To lift the unit, rings are provided in the base frame of the unit. Spreader bar and cables should be arranged to prevent damage to the condenser coil or unit cabinet.

Location

The units are produced for outside installation on roofs, floors or below ground level on condition that the area is free from obstacles for the passage of the condenser air. The unit should be positioned on solid foundations and perfectly level; in the case of installation on roofs or floors, it may be advisable to arrange the use of suitable weight distribution beams. When the units are installed on the ground, a concrete base at least 250 mm wider and longer than the unit's footprint should be laid. Furthermore, this base should withstand the unit weight mentioned in the technical data table.

Space requirements

The units are air-cooled, then it is important to respect the minimum distances which guarantee the best ventilation of the condenser coils. Limitations of space reducing the air flow could cause significant reductions in cooling capacity and an increase in electricity consumption.

To determinate unit placement, careful consideration must be given to assure a sufficient air flow across the condenser heat transfer surface. Two conditions must be avoided to achieve the best performance: warm air recirculation and coil starvation. Both these conditions cause an increase of condensing pressures that results in reductions in unit efficiency and capacity.

Moreover the unique microprocessor has the ability to calculate the operating environment of the air cooled chiller and the capacity to optimize its performance staying on-line during abnormal conditions.

Each side of the unit must be accessible after installation for periodic service. Fig.1 shows you minimum recommended clearance requirements.

Vertical condenser air discharge must be unobstructed because the unit would have its capacity and efficiency significantly reduced.

If the units are positioned in places surrounded by walls or obstacles of the same height as the units, the units should be at least 2500 mm from obstacles (fig.2). In the event the obstacles are higher than the units, the units should be at least 3000 mm from the obstacle (fig.4). Units installed closer than the minimum recommended distance to a wall or other vertical riser may experience a combination of coil starvation and warm air recirculation, thus causing reduction in unit capacity and efficiency reductions. The microprocessor control is proactive in response "of design condition". In the case of single or compounded influences restricting airflow to the unit, the microprocessor will act to keep the compressor(s) running (at reduced capacity) rather than allowing a shut-off on high discharge pressure.

When two or more units are positioned side by side it is recommended that the condenser coils are at least 3600 mm distance from one another (fig.3); strong wind could be the cause of air warm recirculation.

For other installation solutions, consult our technicians.

The above recommended information are representative of general installation. A specific evaluation should be done by contractor depending on the case.

9 Installation

9 - 1 Installation Method

Fig. 1

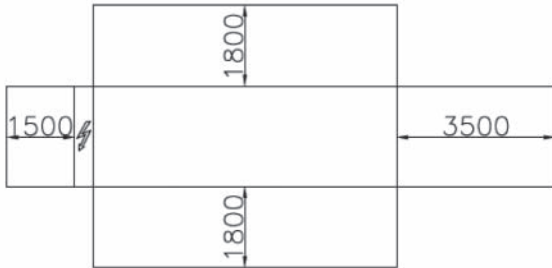

Fig. 2

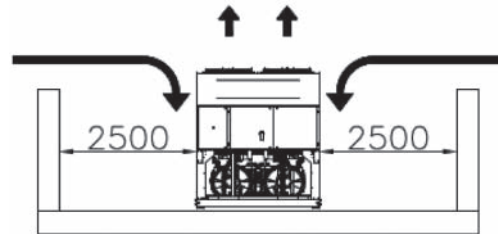

Fig. 3

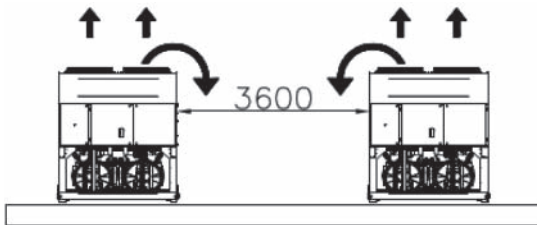
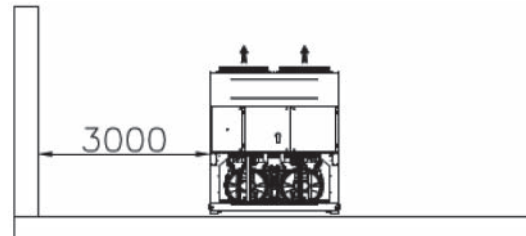

Fig. 4



Acoustic protection

When noise level must meet special requirements, it is necessary to pay the maximum attention to ensure the perfect insulation of the unit from the support base by applying appropriate vibration-dampening devices on the unit, on the water pipes and on the electrical connections.

Storage

The environment conditions have to be in the following limits:

Minimum ambient temperature:	-20°C
Maximum ambient temperature:	+57°C
Maximum R.H.:	95% not condensing

9 Installation

9 - 2 Water Charge, Flow and Quality

Water charge, flow and quality

Items ^{(1) (5)}	Cooling Water			Cooled Water	Heated water ⁽²⁾				Tendency if out of criteria		
	Circulating System		Once Flow		Low temperature		High temperature				
	Circulating water	Supply water ⁽⁴⁾	Flowing water		Circulating water [Below 20°C]	Supply water ⁽⁴⁾	Circulating water [20°C ~ 60°C]	Supply water ⁽⁴⁾		Circulating water [60°C ~ 80°C]	Supply water ⁽⁴⁾
pH	at 25°C	6.5 ~ 8.2	6.0 ~ 8.0	6.0 ~ 8.0	6.8 - 8.0	6.0 ~ 8.0	7.0 ~ 8.0	7.0 ~ 8.0	7.0 ~ 8.0	7.0 ~ 8.0	Corrosion + Scale
Electrical conductivity	[mS/m] at 25°C	Below 80	Below 30	Below 40	Below 80	Below 80	Below 30	Below 30	Below 30	Below 30	Corrosion + Scale
	[μS/cm] at 25°C	(Below 800)	(Below 300)	(Below 400)	(Below 800)	(Below 800)	(Below 300)	(Below 300)	(Below 300)	(Below 300)	Corrosion + Scale
Chloride ion	[mgCl ⁻ /l]	Below 200	Below 50	Below 50	Below 200	Below 50	Below 50	Below 50	Below 30	Below 30	Corrosion
Sulfate ion	[mgSO ₄ ²⁻ /l]	Below 200	Below 50	Below 50	Below 200	Below 50	Below 50	Below 50	Below 30	Below 30	Corrosion
M-alkalinity (pH4.8)	[mgCaCO ₃ /l]	Below 100	Below 50	Below 50	Below 100	Below 50	Below 50	Below 50	Below 50	Below 50	Scale
Total hardness	[mgCaCO ₃ /l]	Below 200	Below 70	Below 70	Below 200	Below 70	Below 70	Below 70	Below 70	Below 70	Scale
Calcium hardness	[mgCaCO ₃ /l]	Below 150	Below 50	Below 50	Below 50	Below 50	Below 50	Below 50	Below 50	Below 50	Scale
Silica ion	[mgSiO ₂ /l]	Below 50	Below 30	Below 30	Below 30	Below 30	Below 30	Below 30	Below 30	Below 30	Scale
Oxygen	(mg O ₂ /l)	Below 1.0	Below 1.0	Below 1.0	Below 1.0	Below 1.0	Below 1.0	Below 1.0	Below 1.0	Below 1.0	Corrosion
Particole size	(mm)	Below 0.5	Below 0.5	Below 0.5	Below 0.5	Below 0.6	Below 0.5	Below 0.6	Below 0.5	Below 0.6	Erosion
Total dissolved solids	(mg /l)	Below 1000	Below 1000	Below 1000	Below 1000	Below 1001	Below 1000	Below 1001	Below 1000	Below 1001	Erosion
Ethykene, Propylene Glycol (weight conc.)		Below 60%	Below 60%	---	Below 60%	Below 60%	Below 60%	Below 60%	Below 60%	Below 60%	--
Nitrate ion	(mg NO ₃ ⁻ /l)	Below 100	Below 100	Below 100	Below 100	Below 101	Below 100	Below 101	Below 100	Below 101	Corrosion
TOC Total organic carbon	(mg /l)	Below 1.0	Below 1.0	Below 1.0	Below 1.0	Below 1.0	Below 1.0	Below 1.0	Below 1.0	Below 1.0	Scale
Iron	[mgFe/l]	Below 1.0	Below 0.3	Below 1.0	Below 1.0	Below 0.3	Below 1.0	Below 0.3	Below 1.0	Below 0.3	Corrosion + Scale
Copper	[mgCu/l]	Below 0.3	Below 0.1	Below 1.0	Below 1.0	Below 1.0	Below 1.0	Below 0.1	Below 1.0	Below 0.1	Corrosion
Sulfite ion	[mgS ²⁻ /l]	Not detectable	Not detectable	Not detectable	Not detectable	Not detectable	Not detectable	Not detectable	Not detectable	Not detectable	Corrosion
Ammonium ion	[mgNH ₄ ⁺ /l]	Below 1.0	Below 0.1	Below 1.0	Below 1.0	Below 0.1	Below 0.3	Below 0.1	Below 0.1	Below 0.1	Corrosion
Remaining chloride	[mgCl/l]	Below 0.3	Below 0.3	Below 0.3	Below 0.3	Below 0.3	Below 0.25	Below 0.3	Below 0.1	Below 0.3	Corrosion
Free carbide	[mgCO ₂ /l]	Below 4.0	Below 4.0	Below 4.0	Below 4.0	Below 4.0	Below 0.4	Below 4.0	Below 0.4	Below 4.0	Corrosion
Stability index		6.0 ~ 7.0	---	---	---	---	---	---	---	---	Corrosion + Scale

Items to be controlled:

Items to be referred to:

wafloqua_1-2_Rev.00_1

2
9

9 Installation

9 - 2 Water Charge, Flow and Quality

Water content in cooling circuits

The cooled water distribution circuits should have minimum water content to avoid excessive compressors start and stop. In fact, each time the compressor starts up, an excessive quantity of oil goes from the compressor sump and simultaneously there is a rise in the temperature of the compressor motor's stator due to the inrush current during the start-up. To prevent damage to the compressors, it has been envisaged the application of a device to limit frequent stops and restarts.

During the span of one hour there will be no more than 6 starts of the compressor. The plant side should therefore ensure that the overall water content allows a more constant functioning of the unit and consequently greater environmental comfort. The minimum water content per unit should be calculated using this simplified formula:

For 2 compressors unit

$$M \text{ (liters)} = (0.1595 \times \Delta T(^{\circ}\text{C}) + 3.0825) \times P(\text{kW})$$

where:

- M minimum water content per unit expressed in litres
- P Cooling Capacity of the unit expressed in kW
- ΔT evaporator entering / leaving water temperature difference expressed in $^{\circ}\text{C}$

This formula is valid for:

- standard microprocessor parameters

For more accurate determination of quantity of water, it is advisable to contact the designer of the plant.

10 Operation range

10 - 1 Operation Range

2
10

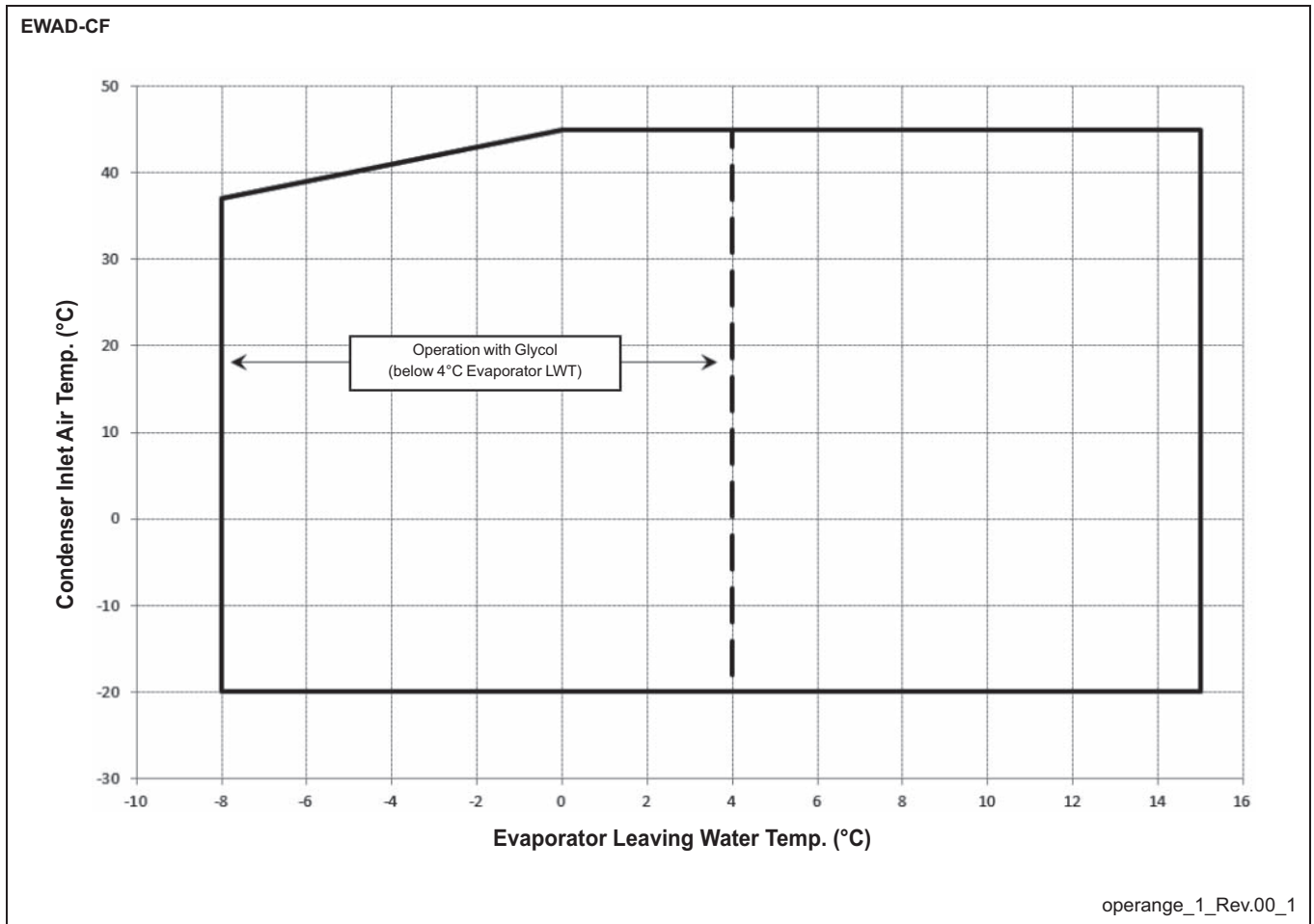

11 Specification text

11 - 1 Specification Text

Technical specification for air cooled chiller

General

The chiller will be designed and manufactured in accordance with the following European directives:

Construction of pressure vessel	97/23/EC (PED)
Machinery Directive	2006/42/EC
Low Voltage	2006/95/EC
Electromagnetic Compatibility	2004/108/EC
Electrical & Safety codes	EN 60204-1 / EN 60335-2-40
Manufacturing Quality Standards	UNI – EN ISO 9001:2004

To avoid any losses, the unit will be tested at full load in the factory (at the nominal working conditions and water temperatures). The chiller will be delivered to the job site completely assembled and charged with refrigerant and oil. The installation of the chiller must comply with the manufacturer's instructions for rigging and handling equipment.

The unit will be able to start up and operate (as standard) at full load with:

- outside air temperature from °C to °C
- evaporator leaving fluid temperature between °C and °C

Refrigerant

Only R-134a can be used.

Performance

- ✓ Number of air cooled screw chiller(s) : unit(s)
- ✓ Cooling capacity for single chiller : kW
- ✓ Power input for single chiller in cooling mode : kW
- ✓ Heat exchanger entering water temperature in cooling mode : °C
- ✓ Heat exchanger leaving water temperature in cooling mode : °C
- ✓ Heat exchanger water flow : l/s
- ✓ Nominal outside working ambient temperature in cooling mode : °C
- ✓ Operating voltage range should be 400V ±10%, 3ph, 50Hz, voltage unbalance maximum 3%, without neutral conductor and shall only have one power connection point.

Unit description

Chiller shall include as standard not less than: two independent refrigerant circuits, semi-hermetic asymmetric type rotary single screw compressors, electronic expansion device (EEXV), refrigerant direct expansion shell & tube heat exchanger, air-cooled condenser section, R134a refrigerant, lubrication system, motor starting components, discharge line shut-of valve, control system and all components necessary for safe and stable unit operation.

Chiller will be factory assembled on a robust base-frame made of galvanized steel, protected by an epoxy paint.

Sound level and vibrations

Sound pressure level at 1 meter distance in free field, semispheric conditions, shall not exceeddB(A). The sound pressure levels must be rated in accordance to ISO 3744. Other types of rating unacceptable. Vibration on the base frame should not exceed 2 mm/s.

Dimensions

Unit dimensions shall not exceed following indications:

- Unit length : mm
- Unit width : mm
- Unit height : mm

Chiller components

Compressors

- ✓ Semi-hermetic, single-screw asymmetric type with one main helical rotor meshing with two diametrical opposed gatorotors. The gatorotors' contact elements shall be constructed of composite material designed for extended life. Electrical motor shall be 2-pole, semi-hermetic, squirrel-cage induction type and cooled by suction gas.
- ✓ The oil injection shall be used in order to get high EER (Energy Efficiency Ratio) also at high condensing pressure and low sound pressure levels in each load condition.
- ✓ The compressor shall be provided with a built in, high efficiency, mesh type oil separator and oil filter.
- ✓ Refrigerant system differential pressure shall provide oil injection on all moving compressor parts to correctly lubricate them. Electrical oil pump lubricating system is not acceptable.

11 Specification text

11 - 1 Specification Text

2

11

- ✓ Compressor cooling must be done by refrigerant liquid injection. External dedicated heat exchanger and additional piping to carry the oil from the compressor to heat exchanger and viceversa will be not accepted.
- ✓ The compressor shall be direct electrical driven, without gear transmission between the screw and the electrical motor.
- ✓ The compressor casing shall be provided with ports to realize economized refrigerant cycles.
- ✓ Compressor must be protected by temperature sensor for high discharge temperature and electrical motor thermistor for high winding temperature.
- ✓ The compressor shall be equipped with an electric oil heater.
- ✓ Compressor shall be fully field serviceable. Compressor that must be removed and returned to the factory for service shall be unacceptable.

Cooling capacity control system

- ✓ Each chiller will have a microprocessor for the control of compressor slide valve position.
- ✓ The unit capacity control shall be infinitely modulating, from 100% down to 25% for each circuit (from 100% down to 12,5% of full load for unit with 2 compressors. The chiller shall be capable of stable operation to a minimum of 12,5% of full load without hot gas bypass.
- ✓ The system shall control the unit based on the leaving evaporator water temperature that shall be controlled by a PID (Proportional Integral Derivative) logic.
- ✓ Unit control logic shall manage the compressor slides to exactly match plant load request in order to keep constant the set point for delivered chilled water temperature.
- ✓ The microprocessor unit control shall detect conditions that approach protective limits and take self-corrective action prior to an alarm occurring. The system shall automatically reduce chiller capacity when any of the following parameters are outside their normal operating range:
 - High condenser pressure
 - Low evaporating refrigerant temperature

Evaporator

- ✓ The units shall be equipped with a Direct Expansion shell&tube evaporator with copper tubes rolled into steel tubesheets. The evaporator shall be single-pass on both the refrigerant and water sides for pure counter-flow heat exchange and low refrigerant pressure drops.
- ✓ The external shell shall be linked with an electrical heater to prevent freezing down to -28°C ambient temperature, controlled by a thermostat and shall be insulated with flexible, closed cell polyurethane insulation material (20-mm thick).
- ✓ The evaporator will have 2, one for each compressor and shall be single refrigerant pass.
- ✓ The water connections shall be FLANGED type connections as standard to ensure quick mechanical disconnection between the unit and the hydronic network.
- ✓ Evaporator is manufactured in accordance to PED approval.

Condenser coil

- ✓ The condenser coils are constructed with internally finned seamless copper tubes having a “W” configuration and arranged in a staggered row pattern and mechanically expanded into lanced and rippled aluminium fins with full fin collars for higher efficiencies. The space between the fins are given by a collar that will increase the surface area in connection with the tubes, protecting them from ambient corrosion.
- ✓ The coils will have an integral subcooler circuit that provides sufficient subcooling to effectively eliminate the possibility of liquid flashing and increase the unit's efficiency of 5-7% without increasing in energy consumption.
- ✓ The condenser coil shall be leak-tested and submitted to a pressure test with dry air.

Condenser fans

- ✓ The fans used in conjunction with the condenser coils, shall be propeller type with glass reinforced resin blades for higher efficiencies and lower noise. Each fan shall be protected by a fan guard.
- ✓ The air discharge shall be vertical and each fan must be coupled to the electrical motor, supplied as standard to IP54 and capable to work to ambient temperatures of - 20°C to + 65°C.
- ✓ They shall have as a standard a thermally protection by internal therma motor protection and protected by ciurcuit braker installed inside the electrical panel as a standard.

Refrigerant circuit

- ✓ The unit must have multiple independent refrigerant circuits.
- ✓ Each circuit shall include as standard: electronic expansion device piloted by unit's microprocessor control, compressor discharge shut-off valve, replaceable core filter-drier, sight glass with moisture indicator and insulated suction line.

Condensation control

- ✓ The units will be provided with an automatic control for condensing pressure which ensures the working at low external temperatures down to - °C, to maintain condensing pressure.
- ✓ Compressor automatically unloads when abnormal high condensing pressure is detected to prevent the shutdown of the refrigerant circuit (shutdown of the unit) due to a high-pressure fault.

11 Specification text

11 - 1 Specification Text

Low sound unit options (on request)

- ✓ The unit compressors shall be connected with unit's metal base frame by rubber antivibration supports to prevent the transmission of vibrations to all metal unit structure and so to control the unit noise.
- ✓ The chiller shall be provided with an acoustically compressor enclosure. This enclosure shall be realized with a light, corrosion resisting aluminium structure and metal panels. The compressors sound-proof enclosure shall be internally fitted with flexible, multi layer, high density materials.

Hydronic kit options (on request)

- ✓ The hydronic module shall be integrated in the chiller chassis without increasing its dimensions and include the following elements: centrifugal water pump with three-phase motor equipped with internal over-temperature protection, safety relief valve, filling kit.
- ✓ The water piping shall be protected against corrosion and equipped with drain and purge plugs. The customer connections shall be Victaulic connections. The piping shall be fully insulated to prevent condensation (pump insulation using polyurethane foam).
- ✓ A choice of two pump types shall be available on unit with 2 compressors:
 - in-line single pump
 - in-line twin pumps

Control panel

- ✓ Field power connection, control interlock terminals, and unit control system should be centrally located in an electric panel (IP 54). Power and starting controls should be separate from safety and operating controls in different compartments of the same panel.
- ✓ Starting will be Wye-Delta type (Y-Δ).
- ✓ Operating and safety controls should include energy saving control; emergency stop switch; overload protection for compressor motor; high and low pressure cut-out switch (for each refrigerant circuit); anti-freeze thermostat; cut-out switch for each compressor.

All of the information regarding the unit will be reported on a display and with the internal built-in calendar and clock that will switch the unit ON/OFF during day time all year long.

- ✓ The following features and functions shall be included:
 - leaving water temperature reset by controlling the water temperature Δt , by a remote 4-20mA DC signal or by controlling the external ambient temperature;
 - soft load function to prevent the system from operating at full load during the chilled fluid pulldown period;
 - password protection of critical parameters of control;
 - start-to-start and stop-to-start timers to provide minimum compressor off-time with maximum motor protection;
 - communication capability with a PC or remote monitoring;
 - discharge pressure control through intelligent cycling of condenser fans;
 - lead-lag selection by manual or automatically by circuit run hours;
 - double set point for brine unit version;
 - scheduling via internal time clock to allow programming of a yearly start-stop schedule accommodating weekends and holidays.

Optional High Level Communications Interface

Chiller must be able to communicate to BMS (Building Management System) based on the most common protocols as:

- ModbusRTU
- LonWorks, now also based on the international 8040 Standard Chiller Profile and LonMark Technology
- BacNet BTP certifier over IP and MS/TP (class 4) (Native)
- Ethernet TCP/IP.

TABLE OF CONTENTS

EWAD-CFXR

1	Features	60
2	Specifications	61
	Technical Specifications	61
	Electrical Specifications	62
3	Features and advantages	63
	Features and Advantages	63
4	General Characteristics	65
	General characteristics	65
5	Nomenclature	69
	Nomenclature	69
6	Capacity tables	70
	Cooling Capacity Tables	70
7	Dimensional drawings	74
	Dimensional Drawings	74
8	Sound data	75
	Sound Level Data	75
9	Installation	76
	Installation Method	76
	Water Charge, Flow and Quality	78
10	Operation range	80
	Operation Range	80
11	Specification text	81
	Specification Text	81

1 Features

- High efficiency, reduced sound levels
- Free cooling chiller
- Greater energy savings and reduced CO₂ emissions during cold season
- Wide capacity range: 11 sizes between 600 and 1.565 kW
- Wide operating range
- MicroTech III controller



3

1



2 Specifications

2-1 Technical Specifications				EWAD 600CFXR	EWAD 740CFXR	EWAD 820CFXR	EWAD 870CFXR	EWAD 980CFXR	EWAD C10CFXR	EWAD C11CFXR	EWAD C12CFXR	EWAD C13CFXR	EWAD C14CFXR	EWAD C15CFXR	
Cooling capacity	Nom.	kW		602 (1) / 270 (2)	739 (1) / 334 (2)	821 (1) / 379 (2)	866 (1) / 409 (2)	981 (1) / 459 (2)	1,034 (1) / 492 (2)	1,229 (1) / 562 (2)	1,302 (1) / 598 (2)	1,374 (1) / 619 (2)	1,424 (1) / 640 (2)	1,476 (1) / 668 (2)	
Capacity control	Method	Stepless													
	Minimum capacity	%	12.5												
Power input	Cooling	Nom.	kW	263 (1) / 70.3 (2)	278 (1) / 84.3 (2)	299 (1) / 88.4 (2)	334 (1) / 95.9 (2)	368 (1) / 106 (2)	412 (1) / 112 (2)	403 (1) / 127 (2)	450 (1) / 141 (2)	466 (1) / 146 (2)	511 (1) / 154 (2)	556 (1) / 161 (2)	
EER				2.29 (1) / 8.56 (2)	2.66 (1) / 8.77 (2)	2.75 (1) / 9.29 (2)	2.59 (1) / 9.03 (2)	2.67 (1) / 9.27 (2)	2.51 (1) / 9.21 (2)	3.05 (1) / 9.67 (2)	2.90 (1) / 9.22 (2)	2.95 (1) / 9.4 (2)	2.79 (1) / 9.26 (2)	2.66 (1) / 9.15 (2)	
ESEER				3.59	3.66	3.89	3.62	3.83	3.63	4.13	3.89	4.09	4.02	3.92	
IPLV				4.08	4.11	4.16	4.18	4.10	4.09	4.40	4.35	4.39	4.37	4.25	
Casing	Colour	Ivory white													
	Material	Galvanized and painted steel sheet													
Dimensions	Unit	Height	mm	2,565											
		Width	mm	2,480											
		Depth	mm	6,185	7,085	7,985	8,885	10,685							
Weight	Unit	kg	8,050	8,620	9,190	10,450	10,710	12,190	12,830	12,910	12,960				
	Operation weight	kg	8,320	8,870	9,430	10,850	11,110	12,580	13,820	13,900	13,950				
Water heat exchanger	Type	Single pass shell & tube													
	Water volume	l	266	251	243	403	386	979							
	Nominal water flow	Cooling	l/s	26.2	32.1	35.7	37.6	42.6	44.9	53.4	56.6	59.7	61.9	64.1	
	Nominal water pressure drop	Cooling	Heat exchanger	kPa	76 / 115 (2)	97 / 159 (2)	84 / 167 (2)	93 / 184 (2)	102 / 225 (2)	113 / 248 (2)	92 / 219 (2)	103 / 243 (2)	128 / 282 (2)	137 / 301 (2)	146 / 321 (2)
	Insulation material	Closed cell													
Air heat exchanger	Type	High efficiency fin and tube type with integral subcooler													
Fan	Quantity	10	12	14	16	20									
	Type	Direct propeller													
	Diameter	mm	800												
	Air flow rate	Nom.	l/s	38,934	46,721	54,508	62,294	73,010							
	Speed	rpm	715												
Fan motor	Drive	Inverter													
	Input	Cooling	W	3,000	3,600	4,000	4,600	4,900	5,600	8,300	6,000	6,600	7,200	7,500	
Sound power level	Cooling	Nom.	dBA	91.5	92.0	92.3	93.5	93.7	94.3	94.5	94.6				
Sound pressure level	Cooling	Nom.	dBA	71.0 (1)	71.5 (1)	72.3 (1)	72.5 (1)	72.2 (1)	72.3 (1)	72.5 (1)					
Compressor	Type	Asymm single screw													
	Quantity	2													
	Oil	Charged volume	l	38	44	50									
Operation range	Water side	Cooling	Min.	°CDB	-8										
			Max.	°CDB	15										
	Air side	Cooling	Min.	°CDB	-20										
			Max.	°CDB	45										
Refrigerant	Type	R-134a													
	Charge	kg	128	146	162	182	214	225	248						
	Circuits	Quantity	2												
Piping connections	Evaporator water inlet/outlet (OD)	DN150PN16(168.3mm)				DN200PN16(219.1mm)				DN250PN16(273mm)					
Mechanical capacity	kW	332 (2)	405 (2)	442 (2)	457 (2)	523 (2)	542 (2)	667 (2)	704 (2)	756 (2)	784 (2)	809 (2)			
Air temperature for free cooling 100%	°C	-2.3	-1.9	-0.6	-1.5	-0.9	-1.7	0.7	-0.2	-1.1	-1.6	-2.3			

3
2

2 Specifications

2-2 Electrical Specifications				EWAD 600CFXR	EWAD 740CFXR	EWAD 820CFXR	EWAD 870CFXR	EWAD 980CFXR	EWAD C10CFXR	EWAD C11CFXR	EWAD C12CFXR	EWAD C13CFXR	EWAD C14CFXR	EWAD C15CFXR	
Compressor	Phase			3~										3~	
	Voltage			400										400	
	Voltage range	Min.	%	-10										-10	
		Max.	%	10										10	
	Maximum running current			A	218	231	274	333	398					451	
Starting method			Wye-delta										Wye-delta		
Compressor 2	Maximum running current			A	218	231	274	333	398					451	
Power supply	Phase			3~											
	Frequency			Hz	50										
	Voltage			V	400										
	Voltage range	Min.	%	-10											
		Max.	%	10											
Unit	Maximum starting current			A	598	611	648	912	960	1,016			1,059	1,072	
	Nominal running current (RLA)	Cooling		A	411	439	473	526	580	647	645	717	738	800	862
		Maximum running current			A	462	493	542	585	649	708	783	847		901
	Max unit current for wires sizing			A	506	540	592	640	710	775	856	927		985	1,044
Fans	Nominal running current (RLA)			A	26	31	36	42	52						

Notes

- (1) Cooling: evaporator 16/10°C, ambient 35°C, unit at full load operation; standard: ISO 3744
- (2) Data is calculated at ambient air temperature 5°C, inlet water temperature 16°C.
- (3) Fluid: water + ethylene glycol 30%
- (4) Allowed voltage tolerance ± 10%. Voltage unbalance between phases must be within ± 3%.
- (5) Maximum starting current: starting current of biggest compressor + 75 % of maximum current of the other compressor + fans current for the circuit at 75 %
- (6) Nominal current in cooling mode: entering evaporator water temp. 12°C; leaving evaporator water temp. 7°C; ambient air temp. 35°C. Compressor + fans current.
- (7) Maximum running current is based on max compressor absorbed current in its envelope and max fans absorbed current
- (8) Maximum unit current for wires sizing is based on minimum allowed voltage.
- (9) Maximum current for wires sizing: (compressors full load ampere + fans current) x 1.1

3 Features and advantages

3 - 1 Features and Advantages

Low operating cost and extended operating life

This chiller range is the result of careful design, aimed to optimize the energy efficiency of the chillers, with the objective of bringing down operating costs and improving installation profitability, effectiveness and economical management.

The chillers feature a high efficiency single screw compressor design, large condenser coil surface area for maximum heat transfer and low discharge pressure, advanced technology condenser fans and a 'shell&tube' evaporator with low refrigerant pressure drops.

The free cooling chillers make use of an additional free cooling section to cool the building water loop directly with the outside ambient air, thus reducing the load on the compressors and considerably decreasing operating costs during the cold season. Free cooling takes advantage of the temperature difference between the outside air and the return water to cool the water before returning it at a lower temperature to be chilled. And when outside temperatures are cold enough the chillers compressors are fully shut down and cooling is practically free. Moreover, cutting compressor usage also extends the chiller's operating life, further minimizing the overall cost of an installation.

Low operating sound levels

Very low sound levels both at full load and part load conditions are achieved by the latest compressor design and by a unique new fan that moves large volume of air at exceptionally low sound levels and by the virtually vibration-free operation.

Outstanding reliability

The chillers have two truly independent refrigerant circuits, in order to assure maximum safety for any maintenance, whether planned or not. They are equipped with a rugged compressor design with advanced composite compressor gaterotors material, a proactive control logic and are full factory-run-tested to optimized trouble-free operation.

Infinite capacity control

Cooling capacity control is infinitely variable by means of a single screw asymmetric compressor controlled by microprocessor system. Each unit has infinitely variable capacity control from 100% down to 12.5%. This modulation allows the compressor capacity to exactly match the building cooling load without any leaving evaporator water temperature fluctuation. This chilled water temperature fluctuation is avoided with a stepless control.

With a compressor load step control in fact, the compressor capacity, at partial loads, will be too high or too low compared to the building cooling load. The result is an increase in chiller energy costs, particularly at the part-load conditions at which the chiller operates most of the time.

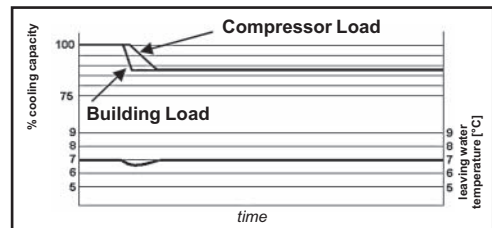

ELWT fluctuation with steps capacity control

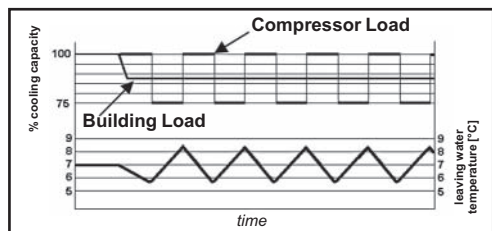

ELWT fluctuation with steps capacity control (4 steps)

Units with stepless regulation offer benefits that the units with step regulation are unable to match. The ability to follow the system energy demand at any time and the possibility to provide steady outlet water temperature without deviations from the set-point, are the two points that allow you to understand how the optimum operating conditions of a system can be met through the use of a unit with stepless regulation.

3 Features and advantages

3 - 1 Features and Advantages

Superior control logic

The new MicroTech III controller provides an easy to use control environment. The control logic is designed to provide maximum efficiency, to continue operation in unusual operating conditions and to provide a history of unit operation. One of the greatest benefits is the easy interface with LonWorks, Bacnet, Ethernet TCP/IP or Modbus communications.

Code requirements – Safety and observant of laws/directives

The range is designed and manufactured in accordance with applicable selections of the following:

Construction of pressure vessel	97/23/EC (PED)
Machinery Directive	2006/42/EC
Low Voltage	2006/95/EC
Electromagnetic Compatibility	2004/108/EC
Electrical & Safety codes	EN 60204–1 / EN 60335-2-40
Manufacturing Quality Stds	UNI – EN ISO 9001:2004

Certifications

All units manufactured by Daikin are CE marked, complying with European directives in force, concerning manufacturing and safety. On request units can be produced complying with laws in force in non European countries (ASME, GOST, etc.), and for other applications, such as naval (RINA, etc.).

Versions

The range is available in three versions:

X: High efficiency

11 sizes to cover a range from 640 up to 1555 kW with an EER up to 3.19 and an ESEER up to 4.01 (data referred to Standard Noise)

The EER (Energy Efficiency Ratio) is the ratio of the Cooling Capacity to the Power Input of the unit. The Power Input includes: the power input for operation of the compressor, the power input of all control and safety devices, the power input for fans.

The ESEER (European Seasonal Energy Efficiency Ratio) is a weighed formula enabling to take into account the variation of EER with the load rate and the variation of air inlet condenser temperature.

$$ESEER = A \times EER_{100\%} + B \times EER_{75\%} + C \times EER_{50\%} + D \times EER_{25\%}$$

	A	B	C	D
Coefficient	0.03 (3%)	0.33 (33%)	0.41 (41%)	0.23 (23%)
Air inlet condenser temperature	35°C	30°C	25°C	20°C

Sound configurations

The range is available in three versions:

S: Standard Sound

Condenser fan rotating at 920 rpm, rubber antivibration under compressor

L: Low Sound

Condenser fan rotating at 920 rpm, rubber antivibration under compressor, compressor sound enclosure.

X: Reduced Sound

Condenser fan rotating at 715 rpm, rubber antivibration under compressor, compressor sound enclosure.

4 General Characteristics

4 - 1 General characteristics

Cabinet and structure

The cabinet is made of galvanized steel sheet and painted to provide a high resistance to corrosion. Colour Ivory White (Munsell code 5Y7.5/1) (\pm RAL7044). The base frame has an eye-hook to lift the unit with ropes for an easy installation. The weight is uniformly distributed along the profiles of the base and this facilitates the arrangement of the unit.

Compressor (Asymmetric Single Screw)

The compressor is semi-hermetic, single-screw type with gate-rotor made with the latest high-strength fibre reinforced star material. The compressor has an asymmetric slide regulation managed by the unit controller for infinitely modulating capacity from 100% to 25%. An integrated high efficiency oil separator maximizes the oil separation and standard start is Wye-delta (Y- Δ) type.

Refrigerant

The compressors have been designed to operate with R-134a, ecological refrigerant with zero ODP (Ozone Depletion Potential) and very low GWP (Global Warming Potential), resulting in low TEWI (Total Equivalent Warming Impact).

Evaporator (Shell&Tube)

The unit is equipped with a direct expansion shell&tube evaporator with copper tubes rolled into steel tubesheets. The evaporators are single-pass on both the refrigerant and water sides for pure counter-flow heat exchange and low refrigerant pressure drops. Both attributes contribute to the heat exchanger effectiveness and total unit's outstanding efficiency.

The external shell is covered with a 20mm closed cell insulation material and the evaporator water outlet connections are provided with flange kit (as standard). Each evaporator has 2 circuits, one for each compressor and is manufactured in accordance to PED approval.

Condenser (Air – Refrigerant heat exchanger)

The condenser is manufactured with internally enhanced seamless copper tubes arranged in a staggered row pattern and mechanically expanded into lanced and rippled aluminum condenser fins with full fin collars. An integral sub-cooler circuit provides sub-cooling to effectively eliminate liquid flashing and increase cooling capacity without increasing the power input.

Free Cooling (Air – Water heat exchanger)

The Free Cooling heat exchanger is manufactured with internally enhanced seamless copper tubes arranged in a staggered row pattern and mechanically expanded into lanced and rippled aluminum condenser fins with full fin collars.

Condenser fans (\varnothing 800)

The condenser fans are propeller type with high efficiency design blades to maximize performances. The material of the blades is glass reinforced resin and each fan is protected by a guard. Fan motors are protected by circuit breakers (installed inside the electrical panel as a standard) and are IP54. Fan speed regulation is standard available (Option 99).

Electronic expansion valve

The unit is equipped with the most advanced electronic expansion valves to achieve precise control of refrigerant mass flow. As today's system requires improved energy efficiency, tighter temperature control, wider range of operating conditions and incorporate features like remote monitoring and diagnostics, the application of electronic expansion valves becomes mandatory. Electronic expansion valves possess unique features: short opening and closing time, high resolution, positive shut-off function to eliminate use of additional solenoid valve, continuous modulation of mass flow without stress in the refrigerant circuit and corrosion resistance stainless steel body. Electronic expansion valves are typically working with lower Δ P between high and low pressure side, than a thermostatic expansion valve. The electronic expansion valve allows the system to work with low condenser pressure (winter time) without any refrigerant flow problems and with a perfect chilled water leaving temperature control.

Refrigerant circuit

Each unit has 2 independent refrigerant circuits and each one includes:

- Compressor with integrated oil separator
- Air Cooled Condenser
- Electronic expansion valve
- Evaporator
- Discharge line shut off valve
- Liquid line shut off valve
- Suction line shut off valve (optional)
- Sight glass with moisture indicator
- Filter drier
- Charging valves
- High pressure switch
- High and low pressure transducers

GNC_1-2-3-4_Rev.00_1

3

4

4 General Characteristics

4 - 1 General characteristics

Free Cooling Water Circuit

“Standard Glycol” Free Cooling

The principal hydraulic circuit is connected directly (through a three way valve) with the free cooling section, creating a circuit with a water-glycol mixture. The free cooling section includes:

- Air-water heat exchanger
- Three way valve (as standard)

Electrical control panel

Power and control are located in the main panel that is manufactured to ensure protection against all weather conditions. The electrical panel is IP54 and (when opening the doors) internally protected with plexiglas panel against possible accidental contact with electrical components (IP20). The main panel is fitted with a main switch interlocked door.

Power Section

The power section includes compressors fuses, fan circuit breaker, fan contactors and control circuit transformer.

MicroTech III controller

MicroTech III controller is installed as standard; it can be used to modify unit set-points and check control parameters. A built-in display shows chiller operating status plus temperatures and pressures of water, refrigerant and air, programmable values, set-points. A sophisticated software with predictive logic, selects the most energy efficient combination of compressors, EEXV and condenser fans to keep stable operating conditions to maximise chiller energy efficiency and reliability.

MicroTech III is able to protect critical components based on external signs from its system (such as motor temperatures, refrigerant gas and oil pressures, correct phase sequence, pressure switches and evaporator). The input coming from the high pressure switch cuts all digital output from the controller in less than 50ms, this is an additional security for the equipment. Fast program cycle (200ms) for a precise monitoring of the system. Floating point calculations supported for increased accuracy in P/T conversions.

Control section - main features

- Management of the compressor stepless capacity and fans modulation.
- Chiller enabled to work in partial failure condition.
- Full routine operation at condition of:
 - high ambient temperature value
 - high thermal load
 - high evaporator entering water temperature (start-up)
- Display of evaporator entering/leaving water temperature.
- Display of Outdoor Ambient Temperature.
- Display of condensing-evaporating temperature and pressure, suction and discharge superheat for each circuit.
- Leaving water evaporator temperature regulation (temperature tolerance = 0,1°C).
- Compressor and evaporator pumps hours counter.
- Display of Status Safety Devices.
- Number of starts and compressor working hours.
- Optimized management of compressor load.
- Fan management according to condensing pressure.
- Re-start in case of power failure (automatic / manual).
- Soft Load (optimized management of the compressor load during the start-up).
- Start at high evaporator water temperature.
- Return Reset (Set Point Reset based on return water temperature).
- OAT (Outside Ambient temperature) Reset.
- Set point Reset (optional).
- Application and system upgrade with commercial SD cards.
- Ethernet port for remote or local servicing using standard web browsers.
- Two different sets of default parameters could be stored for easy restore.

Safety device / logic for each refrigerant circuit

- High pressure (pressure switch).
- High pressure (transducer).
- Low pressure (transducer).
- Fans circuit breaker.
- High compressor discharge temperature.
- High motor winding temperature.
- Phase Monitor.
- Low pressure ratio.
- High oil pressure drop.
- Low oil pressure.
- No pressure change at start.

GNC_1-2-3-4_Rev.00_2

4 General Characteristics

4 - 1 General characteristics

System security

- Phase monitor.
- Low Ambient temperature lock-out.
- Freeze protection.

Regulation type

Proportional + integral + derivative regulation on the evaporator leaving water output probe.

MicroTech III

MicroTech III built-in terminal has the following features.

- 164x44 dots liquid crystal display with white back lighting. Supports Unicode fonts for multi-lingual.
- Key-pad consisting of 3 keys.
- Push'n'Roll control for an increased usability.
- Memory to protect the data.
- General faults alarm relays.
- Password access to modify the setting.
- Application security to prevent application tampering or hardware usability with third party applications.
- Service report displaying all running hours and general conditions.
- Alarm history memory to allow an easy fault analysis.

Supervising systems (on request)

MicroTech III remote control

MicroTech III is able to communicate to BMS (Building Management System) based on the most common protocols as:

- ModbusRTU
- LonWorks, now also based on the international 8040 Standard Chiller Profile and LonMark Technology.
- BacNet BTP certified over IP and MS/TP (class 4) (Native).
- Ethernet TCP/IP.

Standard Options (supplied on basic unit)

Wye-Delta compressor starter (Y-D) - For low inrush current and reduced starting torque

Double setpoint - Dual leaving water temperature setpoints.

Phase monitor - The phase monitor controls that phases sequence is correct and controls phase loss.

Evaporator flange kit

20mm evaporator insulation - The external shell is covered with a 20mm closed cell insulation material.

Evaporator electric heater - Electric heater (controlled by a thermostat) to protect the evaporator from freezing down to -28°C ambient temperature, providing the power supply is on.

Electronic expansion valve

Discharge line shut-off valve - Installed on the discharge port of the compressor to facilitate maintenance operation.

Ambient outside temperature sensor and setpoint reset

Hour run meter

General fault contactor

Setpoint reset, Demand limit and Alarm from external device - (Set-point reset): The leaving water temperature set-point can be overwritten with the following options: 4-20mA from external source (by user); outside ambient temperature; evaporator water temperature Δt . - (Demand limit): User can limit the load of the unit by 4-20mA signal or by network system. - (Alarm from external device): Microprocessor is able to receive an alarm signal from an external device (eg. pump, etc...). User can decide if this alarm signal will stop or not the unit.

Fans circuit breakers - Safety device against motor overloading and short circuit.

Main switch interlock door

Emergency stop

Fans speed regulation (+ fan silent mode) - To control the fan speed revolution for smooth operating control of the unit. This option improves the sound level of the unit during low ambient temperature operation.

Options (on request)

Soft starter - Electronic starting device to reduce the mechanical stress during compressor start-up

Brine version - Allows the unit to operate down to -8°C leaving liquid temperature (antifreeze required).

Compressor thermal overload relays - Safety devices against compressor motor overloading. This device together with internal motor protection (standard) guarantee the best safety system for compressor motor.

Under / Over voltage control - This device control the voltage value of power supply and stop the chiller if the value exceeds the allowed operating limits.

Energy meter - Device installed inside the control box showing ampere and volt values

GNC_1-2-3-4_Rev.00_3

4 General Characteristics

4 - 1 General characteristics

Capacitors for power factor correction - To increase the operating power factor of the unit at nominal operating conditions. The capacitors are “dry” self-regenerating type with over pressure disconnecting safety device insulated with a no toxic dielectric mix with no PCB or PCT.

Current limit - To limit maximum absorbed current of the unit whenever is required

Condenser coil guards

Evaporator area guards

Cu-Cu condenser coil - To give better protection against corrosion by aggressive environments.

Cu-Cu-Sn condenser coil - To give better protection against corrosion in aggressive environments and by salty air.

Alucoat fins coil - Fins are protected by a special acrylic paint with a high resistance to corrosion.

Evaporator flow switch - Supplied separately to be wired and installed on the evaporator water piping (by the customer).

Suction line shut-off valve - Installed on the suction port of the compressor to facilitate maintenance operation.

High pressure side manometers

Low pressure side manometers

Rubber anti vibration mounts - Supplied separately, these are positioned under the base of the unit during installation. Ideal to reduce the vibrations when the unit is floor mounted.

Spring anti vibration mounts - Supplied separately, these are positioned under the base of the unit during installation. Ideal for dampening vibrations for installation on roofs and metallic structures.

One centrifugal pump (low lift) - Hydronic kit consists of: single direct driven centrifugal pump, water filling system with pressure gauge, safety valve, drain valve. The motor pump is protected by a circuit breaker installed in control panel. The kit is assembled and wired to the control panel. The pipe and pump are protected from freezing with an additional electrical heater.

One centrifugal pump (high lift) - Hydronic kit consists of: single direct driven centrifugal pump, water filling system with pressure gauge, safety valve, drain valve. The motor pump is protected by a circuit breaker installed in control panel. The kit is assembled and wired to the control panel. The pipe and pump are protected from freezing with an additional electrical heater.

Two centrifugal pump (low lift) - Hydronic kit consists of: twin direct driven centrifugal pumps, water filling system with pressure gauge, safety valve, drain valve. The motor pump is protected by a circuit breaker installed in control panel. The kit is assembled and wired to the control panel. The pipe and pumps are protected from freezing with an additional electrical heater.

Two centrifugal pump (high lift) - Hydronic kit consists of: twin direct driven centrifugal pumps, water filling system with pressure gauge, safety valve, drain valve. The motor pump is protected by a circuit breaker installed in control panel. The kit is assembled and wired to the control panel. The pipe and pumps are protected from freezing with an additional electrical heater.

Double pressure relief valve with diverter

Compressors circuit breakers

Evaporator right water connections

Ground fault relay - To shut down the entire unit if a ground fault condition is detected.

Rapid restart - It allows the unit to start as fast as 30 seconds after power is restored (in case of power failure).

Transport kit

Optimized free cooling (VFD fans regulation) - This option allows the unit having better performances (better efficiency) in the range of temperatures between Starting Free Cooling (starting free cooling is when the outside temperature is one degree below entering water temperature at the free cooling unit) and Free Cooling 100% (free cooling 100% is when the total load of the installation is satisfied by the free cooling).

Optimized free cooling (On/Off fans) - This option allows the unit having better performances (better efficiency) in the range of temperatures between Starting Free Cooling (starting free cooling is when the outside temperature is one degree below entering water temperature at the free cooling unit) and Free Cooling 100% (free cooling 100% is when the total load of the installation is satisfied by the free cooling).

5 Nomenclature

5 - 1 Nomenclature

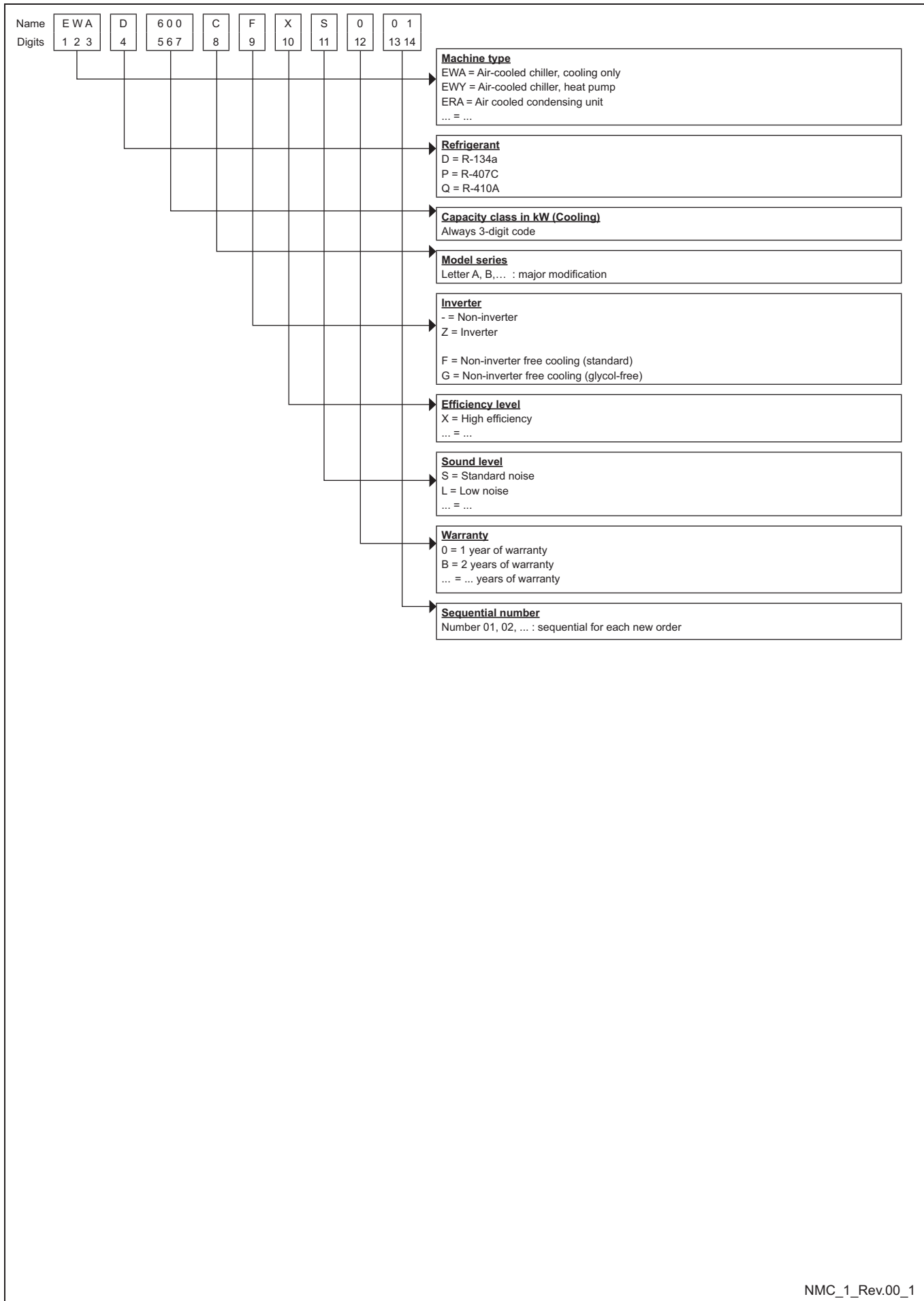

3
5

6 Capacity tables

6 - 1 Cooling Capacity Tables

EWAD-CFXR Cooling performance													
	Twout	8				9				10			
		Ta	CC	PI	qw	dpw	CC	PI	qw	dpw	CC	PI	qw
		kW	kW	l/s	kPa	kW	kW	l/s	kPa	kW	kW	l/s	kPa
600	25	654	219	28,4	89	670	224	29,1	92	686	228	29,8	96
	30	616	236	26,8	79	631	240	27,4	83	647	245	28,1	87
	32	599	243	26,1	75	614	247	26,7	79	629	252	27,4	82
	35	573	253	24,9	70	588	258	25,5	73	602	263	26,2	76
	38	545	264	23,7	63	553	266	24,1	65	559	264	24,3	66
740	40	504	255	21,9	55	509	252	22,1	56	513	249	22,3	57
	25	771	228	33,5	105	790	232	34,3	110	809	236	35,1	114
	30	742	247	32,3	98	760	252	33,0	102	778	256	33,8	107
	32	729	256	31,7	95	746	260	32,4	99	764	265	33,2	103
	35	705	269	30,7	89	722	273	31,4	93	739	278	32,1	97
820	38	679	282	29,5	83	695	287	30,2	87	699	285	30,4	87
	40	636	277	27,6	74	639	274	27,8	74	642	270	27,9	75
	25	849	244	36,9	90	869	248	37,8	94	890	252	38,7	98
	30	820	265	35,7	85	840	270	36,5	88	860	275	37,4	92
	32	806	274	35,1	82	826	279	35,9	86	845	284	36,7	89
870	35	782	288	34,0	77	802	293	34,9	81	821	299	35,7	84
	38	755	303	32,8	72	771	307	33,5	75	780	306	33,9	77
	40	717	301	31,2	66	727	302	31,6	67	738	301	32,1	69
	25	901	272	39,2	101	922	276	40,1	105	942	281	40,9	109
	30	870	296	37,8	94	889	301	38,7	98	909	306	39,5	102
980	32	855	306	37,2	91	874	312	38,0	95	893	317	38,8	99
	35	826	322	35,9	86	846	328	36,8	90	866	334	37,6	93
	38	794	338	34,5	80	808	342	35,1	82	808	336	35,1	82
	40	735	326	32,0	69	739	322	32,1	70	742	317	32,3	70
	25	1026	301	44,6	111	1052	307	45,7	117	1078	313	46,9	122
C10	30	986	327	42,9	104	1010	333	43,9	108	1035	339	45,0	113
	32	967	338	42,0	100	991	344	43,1	104	1015	351	44,1	109
	35	935	354	40,7	94	958	361	41,6	98	981	368	42,6	102
	38	885	363	38,5	85	896	362	38,9	86	912	364	39,6	89
	40	835	357	36,3	76	847	357	36,8	78	860	358	37,4	80
C11	25	1092	337	47,5	125	1118	343	48,6	131	1145	350	49,8	137
	30	1046	366	45,5	116	1071	373	46,5	121	1096	380	47,6	126
	32	1024	378	44,5	111	1048	385	45,6	116	1072	392	46,6	121
	35	986	397	42,9	104	1010	404	43,9	108	1034	412	44,9	113
	38	918	399	39,9	90	917	390	39,9	90	927	389	40,3	92
C12	40	840	376	36,5	77	843	369	36,7	77	852	367	37,0	78
	25	1253	330	54,5	96	1285	335	55,9	101	1318	341	57,3	106
	30	1216	359	52,9	91	1247	365	54,2	95	1279	371	55,6	100
	32	1198	371	52,1	88	1229	377	53,4	93	1260	384	54,8	97
	35	1169	390	50,8	84	1199	397	52,1	88	1229	403	53,4	92
C13	38	1135	410	49,4	80	1164	417	50,6	84	1193	424	51,8	87
	40	1109	424	48,2	76	1137	431	49,4	80	1166	439	50,7	84
	25	1335	367	58,1	109	1369	373	59,5	114	1403	380	61,0	119
	30	1293	400	56,2	102	1326	406	57,6	107	1358	413	59,0	112
	32	1274	413	55,4	99	1305	420	56,7	104	1337	427	58,1	108
C14	35	1240	435	53,9	94	1271	442	55,2	99	1302	450	56,6	103
	38	1201	458	52,2	89	1231	465	53,5	93	1261	473	54,8	97
	40	1172	473	51,0	85	1201	481	52,2	89	1230	489	53,4	93
	25	1420	382	61,8	137	1459	390	63,4	143	1498	397	65,1	150
	30	1369	415	59,5	127	1406	423	61,1	134	1443	431	62,7	140
C15	32	1346	428	58,5	123	1381	436	60,0	129	1417	445	61,6	136
	35	1306	449	56,8	117	1340	458	58,2	122	1374	466	59,7	128
	38	1260	472	54,8	109	1293	480	56,2	114	1326	489	57,6	120
	40	1226	487	53,3	104	1258	496	54,7	109	1273	497	55,3	111
	25	1481	416	64,4	148	1519	424	66,0	155	1557	432	67,7	162
C15	30	1426	453	62,0	138	1462	461	63,6	144	1498	470	65,1	151
	32	1400	468	60,9	133	1435	477	62,4	139	1471	486	63,9	145
	35	1356	492	59,0	125	1390	501	60,4	131	1424	511	61,9	137
	38	1305	518	56,8	117	1321	517	57,4	119	1341	518	58,3	122
	40	1229	509	53,5	104	1252	512	54,4	108	1262	508	54,8	109
C15	25	1546	450	67,2	160	1584	458	68,9	167	1622	467	70,5	175
	30	1486	491	64,6	149	1522	500	66,2	155	1557	509	67,7	162
	32	1457	508	63,3	143	1493	518	64,9	150	1527	527	66,4	156
	35	1407	535	61,2	134	1442	545	62,7	140	1476	556	64,1	146
	38	1351	564	58,8	124	1351	554	58,7	124	1358	547	59,0	125
40	1232	530	53,6	105	1246	528	54,2	107	1251	518	54,3	107	

Fluid: Water + Ethylene Glycol 30%
 Ta: Condenser inlet air temperature; Twout: Evaporator leaving water temperature (Δt6°C)
 CC: Cooling capacity; PI: Power input; qw: Fluid flow rate; dpw: Fluid pressure drop
 * For working condition where dpw value is "Italic-Red Color" please contact factory

6 Capacity tables

6 - 1 Cooling Capacity Tables

EWAD-CFXR Cooling performance													
	Twout	11				12				13			
		Ta	CC	PI	qw	dpw	CC	PI	qw	dpw	CC	PI	qw
		kW	kW	l/s	kPa	kW	kW	l/s	kPa	kW	kW	l/s	kPa
600	25	702	232	30,5	101	719	237	31,2	105	735	242	31,9	109
	30	662	250	28,8	90	677	255	29,4	94	693	260	30,1	98
	32	645	257	28,0	86	660	262	28,6	89	674	267	29,3	93
	35	616	269	26,8	79	631	274	27,4	82	639	275	27,7	84
	38	561	259	24,4	66	565	256	24,5	67	570	253	24,7	68
	40	514	243	22,3	57	521	242	22,6	58	524	237	22,7	59
740	25	828	240	35,9	119	847	245	36,8	124	866	249	37,6	129
	30	796	261	34,6	111	814	266	35,3	116	832	271	36,1	120
	32	781	270	33,9	107	799	275	34,7	112	816	280	35,4	116
	35	756	283	32,8	101	773	289	33,6	105	790	294	34,3	109
	38	702	282	30,5	88	705	279	30,6	89	708	275	30,7	89
	40	644	266	28,0	75	651	264	28,2	76	652	259	28,3	76
820	25	912	257	39,6	103	932	261	40,5	107	952	266	41,3	111
	30	880	279	38,2	96	900	284	39,1	100	920	289	39,9	104
	32	865	289	37,6	93	885	294	38,4	97	904	299	39,2	101
	35	840	304	36,5	88	859	309	37,3	92	878	314	38,1	95
	38	791	307	34,4	79	802	307	34,8	81	816	309	35,4	83
	40	750	303	32,6	71	760	302	33,0	73	766	300	33,2	74
870	25	963	286	41,8	114	983	291	42,7	118	1004	296	43,6	122
	30	928	311	40,3	106	947	317	41,1	110	967	322	42,0	114
	32	911	322	39,6	103	930	328	40,4	106	949	333	41,2	110
	35	884	339	38,4	97	902	345	39,2	100	920	351	39,9	104
	38	812	332	35,3	83	816	327	35,4	83	824	326	35,8	85
	40	750	315	32,6	71	752	309	32,6	71	758	307	32,9	72
980	25	1105	319	48,0	128	1131	325	49,1	133	1157	331	50,2	139
	30	1060	346	46,1	118	1085	352	47,1	123	1110	359	48,2	128
	32	1039	357	45,1	114	1064	364	46,2	119	1088	371	47,2	124
	35	999	371	43,4	106	1013	372	44,0	108	1027	373	44,6	111
	38	925	364	40,2	91	937	364	40,7	94	950	365	41,2	96
	40	863	352	37,5	80	869	348	37,7	81	863	352	37,5	80
C10	25	1172	357	50,9	143	1198	364	52,0	148	1225	371	53,2	154
	30	1121	387	48,7	131	1146	395	49,7	136	1170	402	50,8	142
	32	1097	400	47,6	126	1121	408	48,7	131	1145	415	49,7	136
	35	1045	413	45,4	115	1050	409	45,6	116	1055	404	45,8	117
	38	931	383	40,4	92	933	376	40,5	93	942	373	40,9	94
	40	854	359	37,1	79	861	355	37,4	80	847	367	36,8	77
C11	25	1352	347	58,7	110	1385	352	60,1	115	1419	358	61,6	121
	30	1311	377	56,9	104	1343	383	58,3	109	1375	390	59,7	114
	32	1292	390	56,1	101	1323	396	57,4	106	1355	403	58,8	111
	35	1259	410	54,7	97	1290	417	56,0	101	1321	424	57,3	105
	38	1222	431	53,1	91	1252	438	54,3	95	1281	445	55,6	100
	40	1195	446	51,9	88	1216	449	52,8	90	1233	450	53,5	93
C12	25	1437	386	62,4	124	1472	393	63,9	130	1507	400	65,4	135
	30	1391	420	60,4	117	1424	427	61,8	122	1457	435	63,2	127
	32	1369	435	59,5	113	1401	442	60,8	118	1434	450	62,2	123
	35	1332	457	57,9	108	1363	465	59,2	112	1395	473	60,5	117
	38	1290	481	56,0	101	1320	489	57,3	105	1350	497	58,6	110
	40	1259	497	54,7	97	1273	498	55,3	99	1279	493	55,5	99
C13	25	1538	405	66,8	158	1577	413	68,5	165	1616	421	70,2	173
	30	1480	439	64,3	147	1518	447	65,9	154	1556	456	67,5	161
	32	1454	453	63,1	142	1490	462	64,7	148	1527	470	66,3	155
	35	1409	475	61,2	134	1444	484	62,7	140	1479	493	64,2	146
	38	1359	498	59,0	125	1392	507	60,4	131	1408	508	61,1	133
	40	1280	492	55,6	112	1286	486	55,8	112	1290	479	56,0	113
C14	25	1595	440	69,3	169	1633	448	70,9	177	1671	456	72,5	184
	30	1535	478	66,7	157	1571	487	68,2	164	1606	496	69,7	171
	32	1506	495	65,4	152	1541	504	66,9	158	1576	513	68,4	165
	35	1458	520	63,3	143	1492	530	64,8	149	1513	532	65,7	153
	38	1360	518	59,1	125	1384	522	60,1	129	1393	517	60,5	131
	40	1266	500	55,0	110	1275	495	55,4	111	1282	489	55,7	112
C15	25	1661	476	72,1	182	1699	485	73,8	190	1738	494	75,4	198
	30	1593	519	69,2	169	1629	528	70,7	176	1666	538	72,3	183
	32	1562	537	67,9	163	1597	547	69,3	169	1632	557	70,8	176
	35	1510	566	65,6	153	1543	576	67,0	159	1551	571	67,3	160
	38	1364	539	59,2	126	1378	536	59,8	128	1382	527	60,0	129
	40	1254	508	54,5	108	1265	504	54,9	109	1276	499	55,4	111

Fluid: Water + Ethylene Glycol 30%

Ta: Condenser inlet air temperature; Twout: Evaporator leaving water temperature (Δt 6°C)

CC: Cooling capacity; PI: Power input; qw: Fluid flow rate; dpw: Fluid pressure drop

* For working condition where dpw value is "Italic-Red Color" please contact factory

6 Capacity tables

6 - 1 Cooling Capacity Tables

EWAD-CFXR
Free cooling performance

Twout	8					9					10				
	TFC °C	CC kW	PI kW	qw l/s	dpw kPa	TFC °C	CC kW	PI kW	qw l/s	dpw kPa	TFC °C	CC kW	PI kW	qw l/s	dpw kPa
640	-3,6	573	9,4	24,9	105	-3,0	588	9,4	25,5	110	-2,3	602	9,4	26,2	115
770	-3,2	705	11	30,7	147	-2,6	722	11	31,4	153	-1,9	739	11	32,1	159
850	-2,0	782	12,5	34	153	-1,3	802	12,6	34,9	160	-0,6	821	12,6	35,7	167
900	-2,7	826	12,6	35,9	169	-2,1	846	12,6	36,8	176	-1,5	866	12,5	37,6	184
C10	-2,2	935	14,2	40,7	207	-1,6	958	14,1	41,6	216	-0,9	981	14,2	42,6	225
C11	-3,0	986	14,2	42,9	228	-2,4	1010	14,2	43,9	238	-1,7	1034	14,2	44,9	248
C12	-0,6	1169	17,4	50,8	201	0,0	1199	17,3	52,1	210	0,7	1229	17,4	53,4	219
C13	-1,5	1240	17,3	53,9	224	-0,8	1271	17,4	55,2	233	-0,2	1302	17,4	56,6	243
C14	-2,2	1306	17,5	56,8	258	-1,7	1340	17,3	58,2	270	-1,1	1374	17,4	59,7	282
C15	-2,8	1356	17,5	59	276	-2,2	1390	17,5	60,4	288	-1,6	1424	17,5	61,9	301
C16	-3,4	1407	17,5	61,2	296	-2,9	1442	17,4	62,7	308	-2,3	1476	17,4	64,1	321

Fluid: Water + Ethylene Glycol 30%

Ta: Outdoor air temperature; Twout: unit leaving water temperature (Δt 6°C)

TFC: Air temperature for Free Cooling 100%; CC: Cooling capacity; PI: Power input; qw: Fluid flow rate; dpw: Fluid pressure drop

3
6

6 Capacity tables

6 - 1 Cooling Capacity Tables

EWAD-CFXR
Free cooling performance

Twout	11					12					13				
	TFC °C	CC kW	PI kW	qw l/s	dpw kPa	TFC °C	CC kW	PI kW	qw l/s	dpw kPa	TFC °C	CC kW	PI kW	qw l/s	dpw kPa
640	-1,7	616	9,4	26,8	120	-1,1	631	9,4	27,4	124	-0,3	639	9,4	27,7	127
770	-1,3	756	11	32,8	165	-0,6	773	11	33,6	172	0,0	790	11	34,3	178
850	0,0	840	12,6	36,5	173	0,7	859	12,6	37,3	180	1,3	878	12,6	38,1	187
900	-0,8	884	12,6	38,4	190	-0,1	902	12,6	39,2	197	0,6	920	12,6	39,9	204
C10	-0,2	999	14,2	43,4	232	0,6	1013	14,2	44	238	1,4	1027	14,2	44,6	244
C11	-0,9	1045	14,2	45,4	252	0,0	1050	14,2	45,6	254	0,9	1055	14,2	45,8	256
C12	1,3	1259	17,4	54,7	228	2,0	1290	17,5	56	238	2,6	1321	17,4	57,3	248
C13	0,4	1332	17,3	57,9	253	1,1	1363	17,5	59,2	263	1,7	1395	17,4	60,5	274
C14	-0,5	1409	17,4	61,2	294	0,1	1444	17,4	62,7	307	0,7	1479	17,4	64,2	321
C15	-1,1	1458	17,3	63,3	314	-0,5	1492	17,4	64,8	326	0,3	1513	17,4	65,7	334
C16	-1,7	1510	17,4	65,6	334	-1,1	1543	17,4	67	347	-0,2	1551	17,4	67,3	350

Fluid: Water + Ethylene Glycol 30%

Ta: Outdoor air temperature; Twout: unit leaving water temperature (Δt 6°C)

TFC: Air temperature for Free Cooling 100%; CC: Cooling capacity; PI: Power input; qw: Fluid flow rate; dpw: Fluid pressure drop

7 Dimensional drawings

7 - 1 Dimensional Drawings

EWAD CFX- (Standard Glycol)

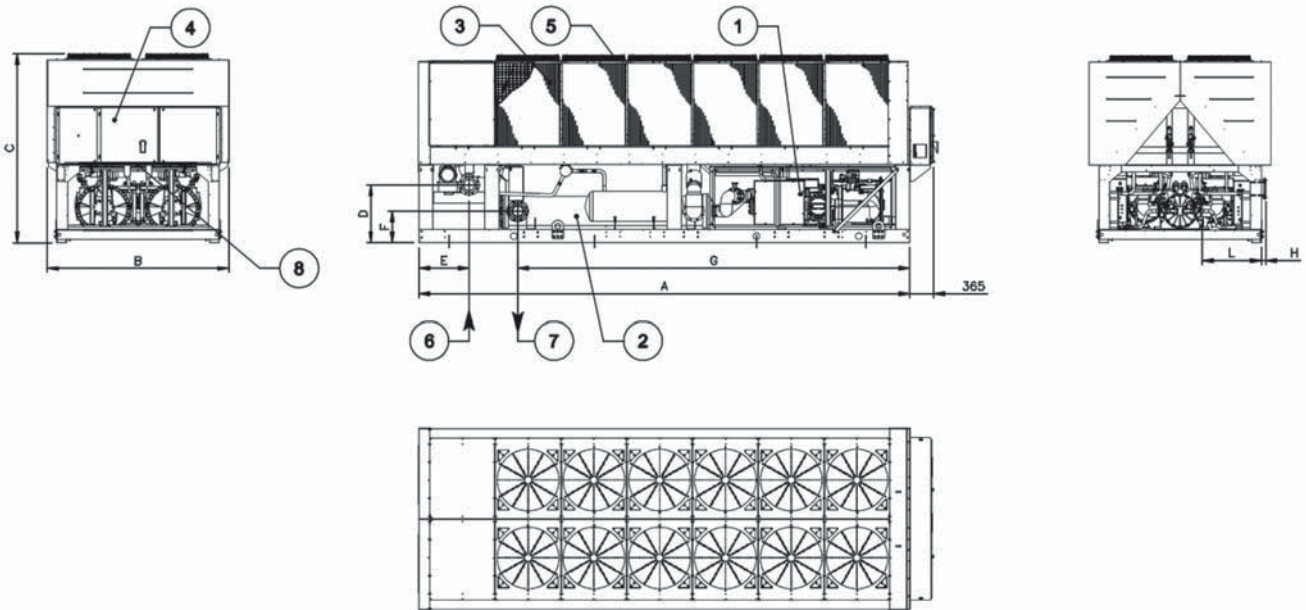

The drawing is for illustration only. Please refer to the table below for unit dimensions.

Models		Dimensions (mm)									
EWAD CFXS/XL	EWAD CFXR	A	B	C	D	E	F	G	H	I	Fans
640	600	5820	2480	2565	795	690	435	5370	75	800	10
770	740	6720	2480	2565	795	690	435	5370	75	800	12
850	820	7620	2480	2565	795	690	435	5370	75	800	14
900	870	7620	2480	2565	795	690	435	5370	75	800	14
C10	980	8520	2480	2565	795	690	540	5355	75	748	16
C11	C10	8520	2480	2565	795	690	540	5355	75	748	16
C12	C11	10320	2480	2565	795	690	540	5355	75	748	20
C13	C12	10320	2480	2565	795	690	540	5355	75	748	20
C14	C13	10320	2480	2565	795	690	540	5355	75	670	20
C15	C14	10320	2480	2565	795	690	540	5355	75	670	20
C16	C15	10320	2480	2565	795	690	540	5355	75	670	20

LEGEND

- 1 – Compressor
- 2 – Evaporator
- 3 – Condenser coil
- 4 – Electrical panel
- 5 – Fan
- 6 – Evaporator water inlet
- 7 – Evaporator water outlet
- 8 – Power connections slot

8 Sound data

8 - 1 Sound Level Data

EWAD-CFXR

MODEL	Sound pressure level at 1 m from the unit (rif. 2 x 10 ⁻⁵ Pa)									Power dB(A)
	63 Hz	125 Hz	250 Hz	500 Hz	1000 Hz	2000 Hz	4000 Hz	8000 Hz	dB(A)	
600	67,6	60,8	67,9	73,1	60,5	56,9	48,6	36,0	71,0	91,5
740	68,1	61,3	68,4	73,6	61,0	57,4	49,1	36,5	71,5	92,0
820	68,1	61,3	68,4	73,6	61,0	57,4	49,1	36,5	71,5	92,3
870	68,1	61,3	68,4	73,6	61,0	57,4	49,1	36,5	71,5	92,3
980	68,9	62,1	69,2	74,4	61,8	58,2	49,9	37,3	72,3	93,5
C10	69,1	62,3	69,4	74,6	62,0	58,4	50,1	37,5	72,5	93,7
C11	68,8	62,0	69,1	74,3	61,7	58,1	49,8	37,2	72,2	94,3
C12	68,9	62,1	69,2	74,4	61,8	58,2	49,9	37,3	72,3	94,5
C13	68,9	62,1	69,2	74,4	61,8	58,2	49,9	37,3	72,3	94,5
C14	69,1	62,3	69,4	74,6	62,0	58,4	50,1	37,5	72,5	94,6
C15	69,1	62,3	69,4	74,6	62,0	58,4	50,1	37,5	72,5	94,6

NOTES

Fluid: Water + Ethylene Glycol 30%

Note: The values are according to ISO 3744 and are referred to: evaporator 12/7° C, air ambient 35°C, full load operation

NSL_1-2-3_Rev.00_3

9 Installation

9 - 1 Installation Method

Installation notes

Warning

Installation and maintenance of the unit must be performed only by qualified personnel who have knowledge with local codes and regulations, and experience with this type of equipment. Must be avoided the unit installation in places that could be considered dangerous for all the maintenance operations.

Handling

Care should be taken to avoid rough handling or shock due to dropping the unit. Do not push or pull the unit from anything other than the base frame. Never allow the unit to fall during unloading or moving as this may result in serious damage. To lift the unit, rings are provided in the base frame of the unit. Spreader bar and cables should be arranged to prevent damage to the condenser coil or unit cabinet.

Location

The units are produced for outside installation on roofs, floors or below ground level on condition that the area is free from obstacles for the passage of the condenser air. The unit should be positioned on solid foundations and perfectly level; in the case of installation on roofs or floors, it may be advisable to arrange the use of suitable weight distribution beams. When the units are installed on the ground, a concrete base at least 250 mm wider and longer than the unit's footprint should be laid. Furthermore, this base should withstand the unit weight mentioned in the technical data table.

Space requirements

The units are air-cooled, then it is important to respect the minimum distances which guarantee the best ventilation of the condenser coils. Limitations of space reducing the air flow could cause significant reductions in cooling capacity and an increase in electricity consumption.

To determinate unit placement, careful consideration must be given to assure a sufficient air flow across the condenser heat transfer surface. Two conditions must be avoided to achieve the best performance: warm air recirculation and coil starvation. Both these conditions cause an increase of condensing pressures that results in reductions in unit efficiency and capacity.

Moreover the unique microprocessor has the ability to calculate the operating environment of the air cooled chiller and the capacity to optimize its performance staying on-line during abnormal conditions.

Each side of the unit must be accessible after installation for periodic service. Fig.1 shows you minimum recommended clearance requirements.

Vertical condenser air discharge must be unobstructed because the unit would have its capacity and efficiency significantly reduced.

If the units are positioned in places surrounded by walls or obstacles of the same height as the units, the units should be at least 2500 mm from obstacles (fig.2). In the event the obstacles are higher than the units, the units should be at least 3000 mm from the obstacle (fig.4). Units installed closer than the minimum recommended distance to a wall or other vertical riser may experience a combination of coil starvation and warm air recirculation, thus causing reduction in unit capacity and efficiency reductions. The microprocessor control is proactive in response "of design condition". In the case of single or compounded influences restricting airflow to the unit, the microprocessor will act to keep the compressor(s) running (at reduced capacity) rather than allowing a shut-off on high discharge pressure.

When two or more units are positioned side by side it is recommended that the condenser coils are at least 3600 mm distance from one another (fig.3); strong wind could be the cause of air warm recirculation.

For other installation solutions, consult our technicians.

The above recommended information are representative of general installation. A specific evaluation should be done by contractor depending on the case.

9 Installation

9 - 1 Installation Method

Fig. 1

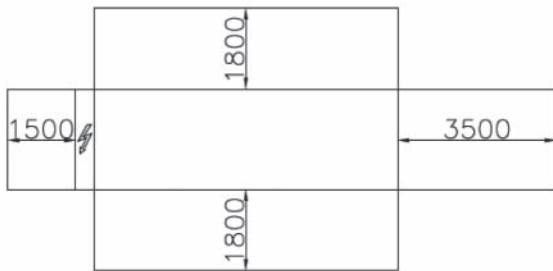

Fig. 2

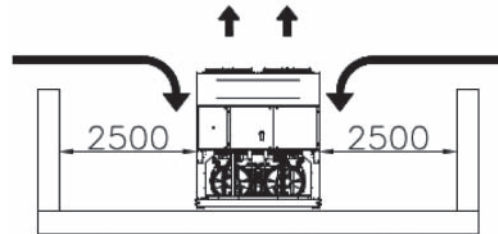

Fig. 3

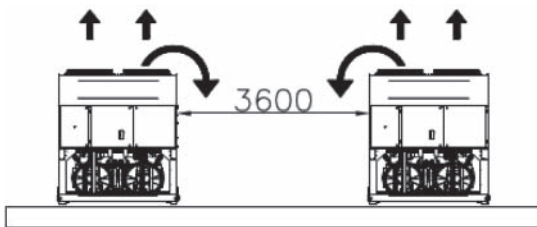
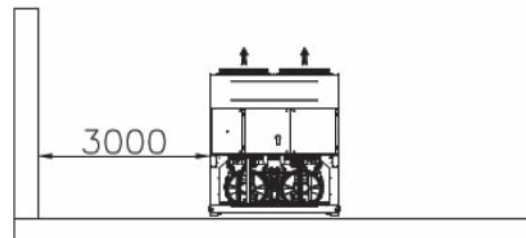

Fig. 4



Acoustic protection

When noise level must meet special requirements, it is necessary to pay the maximum attention to ensure the perfect insulation of the unit from the support base by applying appropriate vibration-dampening devices on the unit, on the water pipes and on the electrical connections.

Storage

The environment conditions have to be in the following limits:

Minimum ambient temperature:	-20°C
Maximum ambient temperature:	+57°C
Maximum R.H.:	95% not condensing

9 Installation

9 - 2 Water Charge, Flow and Quality

Water charge, flow and quality

Items ^{(1) (5)}	Cooling Water			Cooled Water	Heated water ⁽²⁾				Tendency if out of criteria		
	Circulating System		Once Flow		Low temperature		High temperature				
	Circulating water	Supply water ⁽⁴⁾	Flowing water		Circulating water [20°C ~ 60°C]	Supply water ⁽⁴⁾	Circulating water [60°C ~ 80°C]	Supply water ⁽⁴⁾			
pH	at 25°C	6.5 ~ 8.2	6.0 ~ 8.0	6.0 ~ 8.0	6.8 ~ 8.0	6.0 ~ 8.0	7.0 ~ 8.0	7.0 ~ 8.0	7.0 ~ 8.0	7.0 ~ 8.0	Corrosion + Scale
Electrical conductivity	[mS/m] at 25°C	Below 80	Below 30	Below 40	Below 80	Below 80	Below 30	Below 30	Below 30	Below 30	Corrosion + Scale
	[μS/cm] at 25°C	(Below 800)	(Below 300)	(Below 400)	(Below 800)	(Below 800)	(Below 300)	(Below 300)	(Below 300)	(Below 300)	Corrosion + Scale
Chloride ion	[mgCl ⁻ /l]	Below 200	Below 50	Below 50	Below 200	Below 50	Below 50	Below 50	Below 30	Below 30	Corrosion
Sulfate ion	[mgSO ₄ ²⁻ /l]	Below 200	Below 50	Below 50	Below 200	Below 50	Below 50	Below 50	Below 30	Below 30	Corrosion
M-alkalinity (pH4.8)	[mgCaCO ₃ /l]	Below 100	Below 50	Below 50	Below 100	Below 50	Below 50	Below 50	Below 50	Below 50	Scale
Total hardness	[mgCaCO ₃ /l]	Below 200	Below 70	Below 70	Below 200	Below 70	Below 70	Below 70	Below 70	Below 70	Scale
Calcium hardness	[mgCaCO ₃ /l]	Below 150	Below 50	Below 50	Below 50	Below 50	Below 50	Below 50	Below 50	Below 50	Scale
Silica ion	[mgSiO ₂ /l]	Below 50	Below 30	Below 30	Below 30	Below 30	Below 30	Below 30	Below 30	Below 30	Scale
Oxygen	(mg O ₂ /l)	Below 1.0	Below 1.0	Below 1.0	Below 1.0	Below 1.0	Below 1.0	Below 1.0	Below 1.0	Below 1.0	Corrosion
Particole size	(mm)	Below 0.5	Below 0.5	Below 0.5	Below 0.5	Below 0.6	Below 0.5	Below 0.6	Below 0.5	Below 0.6	Erosion
Total dissolved solids	(mg /l)	Below 1000	Below 1000	Below 1000	Below 1000	Below 1001	Below 1000	Below 1001	Below 1000	Below 1001	Erosion
Ethykene, Propylene Glycol (weight conc.)		Below 60%	Below 60%	---	Below 60%	Below 60%	Below 60%	Below 60%	Below 60%	Below 60%	--
Nitrate ion	(mg NO ₃ ⁻ /l)	Below 100	Below 100	Below 100	Below 100	Below 101	Below 100	Below 101	Below 100	Below 101	Corrosion
TOC Total organic carbon	(mg /l)	Below 1.0	Below 1.0	Below 1.0	Below 1.0	Below 1.0	Below 1.0	Below 1.0	Below 1.0	Below 1.0	Scale
Iron	[mgFe/l]	Below 1.0	Below 0.3	Below 1.0	Below 1.0	Below 0.3	Below 1.0	Below 0.3	Below 1.0	Below 0.3	Corrosion + Scale
Copper	[mgCu/l]	Below 0.3	Below 0.1	Below 1.0	Below 1.0	Below 1.0	Below 1.0	Below 0.1	Below 1.0	Below 0.1	Corrosion
Sulfite ion	[mgS ²⁻ /l]	Not detectable	Not detectable	Not detectable	Not detectable	Not detectable	Not detectable	Not detectable	Not detectable	Not detectable	Corrosion
Ammonium ion	[mgNH ₄ ⁺ /l]	Below 1.0	Below 0.1	Below 1.0	Below 1.0	Below 0.1	Below 0.3	Below 0.1	Below 0.1	Below 0.1	Corrosion
Remaining chloride	[mgCl/l]	Below 0.3	Below 0.3	Below 0.3	Below 0.3	Below 0.3	Below 0.25	Below 0.3	Below 0.1	Below 0.3	Corrosion
Free carbide	[mgCO ₂ /l]	Below 4.0	Below 4.0	Below 4.0	Below 4.0	Below 4.0	Below 0.4	Below 4.0	Below 0.4	Below 4.0	Corrosion
Stability index		6.0 ~ 7.0	---	---	---	---	---	---	---	---	Corrosion + Scale

wafloqua_1-2_Rev.00_1

3

9

9 Installation

9 - 2 Water Charge, Flow and Quality

Water content in cooling circuits

The cooled water distribution circuits should have minimum water content to avoid excessive compressors start and stop. In fact, each time the compressor starts up, an excessive quantity of oil goes from the compressor sump and simultaneously there is a rise in the temperature of the compressor motor's stator due to the inrush current during the start-up. To prevent damage to the compressors, it has been envisaged the application of a device to limit frequent stops and restarts.

During the span of one hour there will be no more than 6 starts of the compressor. The plant side should therefore ensure that the overall water content allows a more constant functioning of the unit and consequently greater environmental comfort. The minimum water content per unit should be calculated using this simplified formula:

For 2 compressors unit

$$M \text{ (liters)} = (0.1595 \times \Delta T(^{\circ}\text{C}) + 3.0825) \times P(\text{kW})$$

where:

- M minimum water content per unit expressed in litres
- P Cooling Capacity of the unit expressed in kW
- ΔT evaporator entering / leaving water temperature difference expressed in $^{\circ}\text{C}$

This formula is valid for:

- standard microprocessor parameters

For more accurate determination of quantity of water, it is advisable to contact the designer of the plant.

10 Operation range

10 - 1 Operation Range

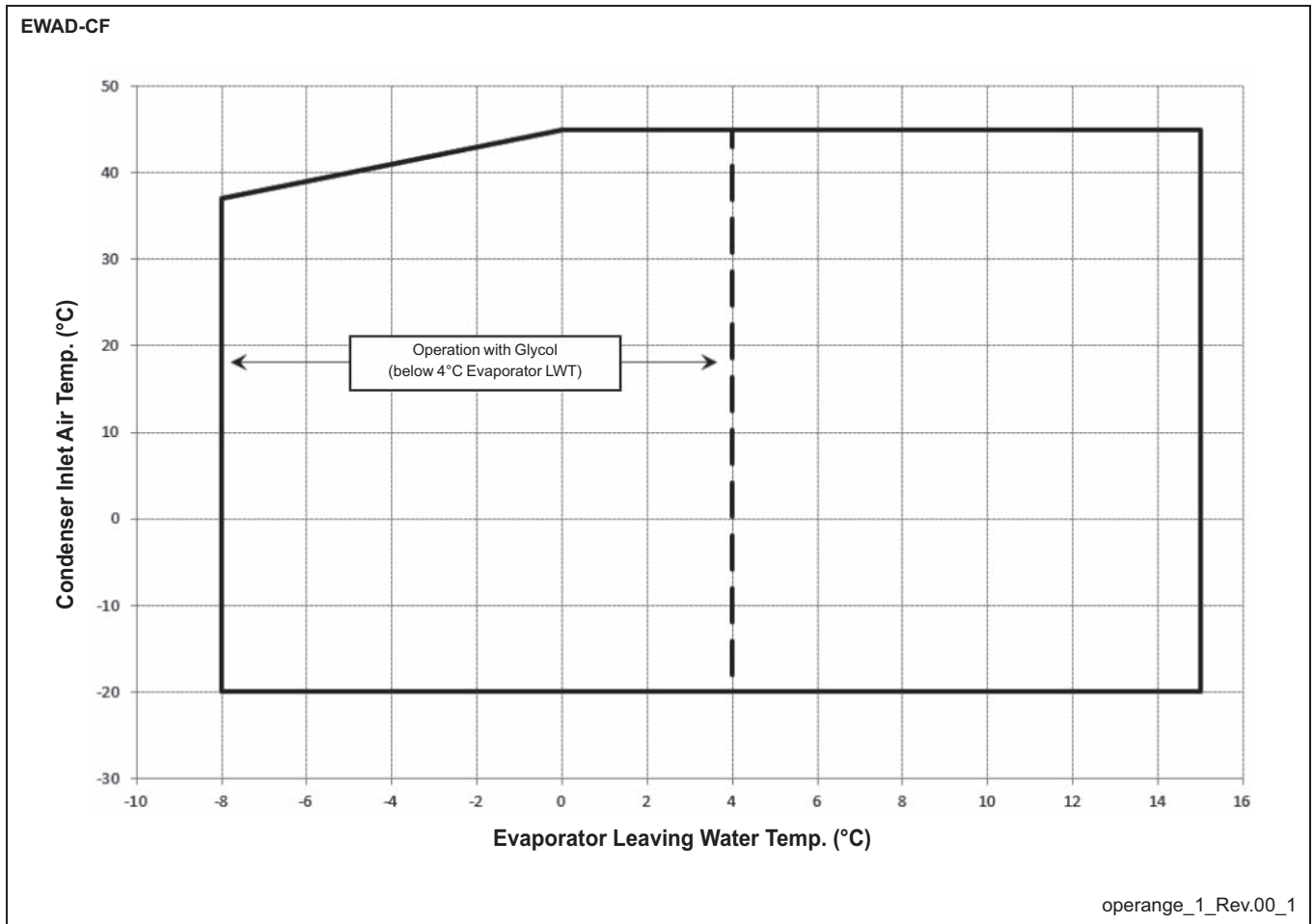

3
10

11 Specification text

11 - 1 Specification Text

Technical specification for air cooled chiller

General

The chiller will be designed and manufactured in accordance with the following European directives:

Construction of pressure vessel	97/23/EC (PED)
Machinery Directive	2006/42/EC
Low Voltage	2006/95/EC
Electromagnetic Compatibility	2004/108/EC
Electrical & Safety codes	EN 60204-1 / EN 60335-2-40
Manufacturing Quality Standards	UNI – EN ISO 9001:2004

To avoid any losses, the unit will be tested at full load in the factory (at the nominal working conditions and water temperatures). The chiller will be delivered to the job site completely assembled and charged with refrigerant and oil. The installation of the chiller must comply with the manufacturer's instructions for rigging and handling equipment.

The unit will be able to start up and operate (as standard) at full load with:

- outside air temperature from °C to °C
- evaporator leaving fluid temperature between °C and °C

Refrigerant

Only R-134a can be used.

Performance

- ✓ Number of air cooled screw chiller(s) : unit(s)
- ✓ Cooling capacity for single chiller : kW
- ✓ Power input for single chiller in cooling mode : kW
- ✓ Heat exchanger entering water temperature in cooling mode : °C
- ✓ Heat exchanger leaving water temperature in cooling mode : °C
- ✓ Heat exchanger water flow : l/s
- ✓ Nominal outside working ambient temperature in cooling mode : °C
- ✓ Operating voltage range should be 400V ±10%, 3ph, 50Hz, voltage unbalance maximum 3%, without neutral conductor and shall only have one power connection point.

Unit description

Chiller shall include as standard not less than: two independent refrigerant circuits, semi-hermetic asymmetric type rotary single screw compressors, electronic expansion device (EEXV), refrigerant direct expansion shell & tube heat exchanger, air-cooled condenser section, R134a refrigerant, lubrication system, motor starting components, discharge line shut-of valve, control system and all components necessary for safe and stable unit operation.

Chiller will be factory assembled on a robust base-frame made of galvanized steel, protected by an epoxy paint.

Sound level and vibrations

Sound pressure level at 1 meter distance in free field, semispheric conditions, shall not exceeddB(A). The sound pressure levels must be rated in accordance to ISO 3744. Other types of rating unacceptable. Vibration on the base frame should not exceed 2 mm/s.

Dimensions

Unit dimensions shall not exceed following indications:

- Unit length mm
- Unit width mm
- Unit height mm

Chiller components

Compressors

- ✓ Semi-hermetic, single-screw asymmetric type with one main helical rotor meshing with two diametrical opposed gatorotors. The gatorotors' contact elements shall be constructed of composite material designed for extended life. Electrical motor shall be 2-pole, semi-hermetic, squirrel-cage induction type and cooled by suction gas.
- ✓ The oil injection shall be used in order to get high EER (Energy Efficiency Ratio) also at high condensing pressure and low sound pressure levels in each load condition.
- ✓ The compressor shall be provided with a built in, high efficiency, mesh type oil separator and oil filter.
- ✓ Refrigerant system differential pressure shall provide oil injection on all moving compressor parts to correctly lubricate them. Electrical oil pump lubricating system is not acceptable.

11 Specification text

11 - 1 Specification Text

- ✓ Compressor cooling must be done by refrigerant liquid injection. External dedicated heat exchanger and additional piping to carry the oil from the compressor to heat exchanger and viceversa will be not accepted.
- ✓ The compressor shall be direct electrical driven, without gear transmission between the screw and the electrical motor.
- ✓ The compressor casing shall be provided with ports to realize economized refrigerant cycles.
- ✓ Compressor must be protected by temperature sensor for high discharge temperature and electrical motor thermistor for high winding temperature.
- ✓ The compressor shall be equipped with an electric oil heater.
- ✓ Compressor shall be fully field serviceable. Compressor that must be removed and returned to the factory for service shall be unacceptable.

Cooling capacity control system

- ✓ Each chiller will have a microprocessor for the control of compressor slide valve position.
- ✓ The unit capacity control shall be infinitely modulating, from 100% down to 25% for each circuit (from 100% down to 12,5% of full load for unit with 2 compressors. The chiller shall be capable of stable operation to a minimum of 12,5% of full load without hot gas bypass.
- ✓ The system shall control the unit based on the leaving evaporator water temperature that shall be controlled by a PID (Proportional Integral Derivative) logic.
- ✓ Unit control logic shall manage the compressor slides to exactly match plant load request in order to keep constant the set point for delivered chilled water temperature.
- ✓ The microprocessor unit control shall detect conditions that approach protective limits and take self-corrective action prior to an alarm occurring. The system shall automatically reduce chiller capacity when any of the following parameters are outside their normal operating range:
 - High condenser pressure
 - Low evaporating refrigerant temperature

Evaporator

- ✓ The units shall be equipped with a Direct Expansion shell&tube evaporator with copper tubes rolled into steel tubesheets. The evaporator shall be single-pass on both the refrigerant and water sides for pure counter-flow heat exchange and low refrigerant pressure drops.
- ✓ The external shell shall be linked with an electrical heater to prevent freezing down to -28°C ambient temperature, controlled by a thermostat and shall be insulated with flexible, closed cell polyurethane insulation material (20-mm thick).
- ✓ The evaporator will have 2, one for each compressor and shall be single refrigerant pass.
- ✓ The water connections shall be FLANGED type connections as standard to ensure quick mechanical disconnection between the unit and the hydronic network.
- ✓ Evaporator is manufactured in accordance to PED approval.

Condenser coil

- ✓ The condenser coils are constructed with internally finned seamless copper tubes having a "W" configuration and arranged in a staggered row pattern and mechanically expanded into lanced and rippled aluminium fins with full fin collars for higher efficiencies. The space between the fins are given by a collar that will increase the surface area in connection with the tubes, protecting them from ambient corrosion.
- ✓ The coils will have an integral subcooler circuit that provides sufficient subcooling to effectively eliminate the possibility of liquid flashing and increase the unit's efficiency of 5-7% without increasing in energy consumption.
- ✓ The condenser coil shall be leak-tested and submitted to a pressure test with dry air.

Condenser fans

- ✓ The fans used in conjunction with the condenser coils, shall be propeller type with glass reinforced resin blades for higher efficiencies and lower noise. Each fan shall be protected by a fan guard.
- ✓ The air discharge shall be vertical and each fan must be coupled to the electrical motor, supplied as standard to IP54 and capable to work to ambient temperatures of - 20°C to + 65°C.
- ✓ They shall have as a standard a thermal protection by internal thermal motor protection and protected by circuit breaker installed inside the electrical panel as a standard.

Refrigerant circuit

- ✓ The unit must have multiple independent refrigerant circuits.
- ✓ Each circuit shall include as standard: electronic expansion device piloted by unit's microprocessor control, compressor discharge shut-off valve, replaceable core filter-drier, sight glass with moisture indicator and insulated suction line.

Condensation control

- ✓ The units will be provided with an automatic control for condensing pressure which ensures the working at low external temperatures down to - °C, to maintain condensing pressure.
- ✓ Compressor automatically unloads when abnormal high condensing pressure is detected to prevent the shutdown of the refrigerant circuit (shutdown of the unit) due to a high-pressure fault.

11 Specification text

11 - 1 Specification Text

Low sound unit options (on request)

- ✓ The unit compressors shall be connected with unit's metal base frame by rubber antivibration supports to prevent the transmission of vibrations to all metal unit structure and so to control the unit noise.
- ✓ The chiller shall be provided with an acoustically compressor enclosure. This enclosure shall be realized with a light, corrosion resisting aluminium structure and metal panels. The compressors sound-proof enclosure shall be internally fitted with flexible, multi layer, high density materials.

Hydronic kit options (on request)

- ✓ The hydronic module shall be integrated in the chiller chassis without increasing its dimensions and include the following elements: centrifugal water pump with three-phase motor equipped with internal over-temperature protection, safety relief valve, filling kit.
- ✓ The water piping shall be protected against corrosion and equipped with drain and purge plugs. The customer connections shall be Victaulic connections. The piping shall be fully insulated to prevent condensation (pump insulation using polyurethane foam).
- ✓ A choice of two pump types shall be available on unit with 2 compressors:
 - in-line single pump
 - in-line twin pumps

Control panel

- ✓ Field power connection, control interlock terminals, and unit control system should be centrally located in an electric panel (IP 54). Power and starting controls should be separate from safety and operating controls in different compartments of the same panel.
- ✓ Starting will be Wye-Delta type (Y-Δ).
- ✓ Operating and safety controls should include energy saving control; emergency stop switch; overload protection for compressor motor; high and low pressure cut-out switch (for each refrigerant circuit); anti-freeze thermostat; cut-out switch for each compressor.

All of the information regarding the unit will be reported on a display and with the internal built-in calendar and clock that will switch the unit ON/OFF during day time all year long.

- ✓ The following features and functions shall be included:
 - leaving water temperature reset by controlling the water temperature Δt , by a remote 4-20mA DC signal or by controlling the external ambient temperature;
 - soft load function to prevent the system from operating at full load during the chilled fluid pulldown period;
 - password protection of critical parameters of control;
 - start-to-start and stop-to-start timers to provide minimum compressor off-time with maximum motor protection;
 - communication capability with a PC or remote monitoring;
 - discharge pressure control through intelligent cycling of condenser fans;
 - lead-lag selection by manual or automatically by circuit run hours;
 - double set point for brine unit version;
 - scheduling via internal time clock to allow programming of a yearly start-stop schedule accommodating weekends and holidays.

Optional High Level Communications Interface

Chiller must be able to communicate to BMS (Building Management System) based on the most common protocols as:

- ModbusRTU
- LonWorks, now also based on the international 8040 Standard Chiller Profile and LonMark Technology
- BacNet BTP certifier over IP and MS/TP (class 4) (Native)
- Ethernet TCP/IP.



Daikin's unique position as a manufacturer of air conditioning equipment, compressors and refrigerants has led to its close involvement in environmental issues. For several years Daikin has had the intention to become a leader in the provision of products that have limited impact on the environment. This challenge demands the eco design and development of a wide range of products and an energy management system, resulting in energy conservation and a reduction of waste.



Daikin Europe N.V. participates in the Eurovent Certification programme for Air Conditioners (AC), Liquid Chilling Packages (LCP) and Fan Coil Units (FC); the certified data of certified models are listed in the Eurovent Directory. Multi units are Eurovent certified for combinations up to 2 indoor units.

The present leaflet is drawn up by way of information only and does not constitute an offer binding upon Daikin Europe N.V. Daikin Europe N.V. has compiled the content of this leaflet to the best of its knowledge. No express or implied warranty is given for the completeness, accuracy, reliability or fitness for particular purpose of its content and the products and services presented therein. Specifications are subject to change without prior notice. Daikin Europe N.V. explicitly rejects any liability for any direct or indirect damage, in the broadest sense, arising from or related to the use and/or interpretation of this leaflet. All content is copyrighted by Daikin Europe N.V.



Daikin products are distributed by: