



Chillers

# Technical Data

Air Cooled Chiller with centrifugal fan



ECDEN12-402

EUWAC-FBZW1

**R-407C**

Chillers

# Technical Data

Air Cooled Chiller with centrifugal fan



ECDEN12-402

EUWAC-FBZW1

**R-407C**

# TABLE OF CONTENTS

## EUWAC-FBZW1

1	Features .....	2
2	Specifications .....	3
	Technical Specifications .....	3
	Electrical Specifications .....	4
3	Options .....	5
	Options .....	5
4	Control systems .....	6
	Control Systems .....	6
5	Capacity tables .....	7
	Cooling Capacity Tables .....	7
6	Dimensional drawings .....	9
	Dimensional Drawings .....	9
7	Piping diagrams .....	10
	Piping Diagrams .....	10
8	Wiring diagrams .....	11
	Wiring Diagrams - Three Phase .....	11
9	Sound data .....	13
	Sound Power Spectrum .....	13
10	Installation .....	14
	Water Charge, Flow and Quality .....	14
11	Operation range .....	15
	Operation Range .....	15
12	Hydraulic performance .....	16
	Water Pressure Drop Curve Evaporator .....	16
13	Aeraulic performance .....	17
	Available external static pressure .....	17

# 1 Features

- Optimised for use with R-407C
- Daikin scroll compressor
- Electronic DDC controller
- Standard phase sequence controller
- Maximum external static pressure (ESP): 150Pa
- Pressure gauges
- Standard operation range down to -10°C
- Regulating switch
- Water inlet or outlet temperature control
- Input contacts/available outputs
- Input: on/off (per circuit), pump/flow switch
- Output: compressor operation, summary alarm, pump relay contact
- Compatible with hydraulic module



## 2 Specifications

2-1 Technical Specifications					EUWAC5FBZW1	EUWAC8FBZW1	EUWAC10FBZW1
Cooling capacity	Nom.		kW	11.6	18.4	23.8	
Capacity steps			%	100-0			
Power input	Cooling	Nom.	kW	5.2	7.66	9.67	
EER				2.23	2.40	2.46	
Casing	Colour			Ivory white (Munsell code: 5Y7.5/1)			
	Material			Polyester coated galvanised steel plate			
Dimensions	Unit	Height	mm	1,345	1,290	1,395	
		Width	mm	856	1,180	1,330	
		Depth	mm	630			
Weight	Unit		kg	164	224	261	
	Operation weight		kg	166	228	266	
Water heat exchanger - evaporator	Type			Braze plate, one per circuit			
	Minimum water volume in the system		l	101	153	212	
	Water flow rate	Min.	l/min	16	23	28	
		Nom.	l/min	33	53	68	
		Max.	l/min	64	92	112	
	Nominal water pressure drop	Cooling	Heat exchanger	kPa	26	42	48
				Insulation material			PVC nitril foam
	Model	Type		AC70-24	AC70-34	AC70-40	
Quantity			1				
Air heat exchanger	Type			Cross fin coil/Hi-X tubes and PE coated waffle louvre fins			
	Rows	Quantity		3			
	Stages	Quantity		6+2	11+2	13+2	
	Fin pitch	mm		2			
	Face area	m <sup>2</sup>		0.472	0.772	0.950	
Fan	Quantity			1			
	Type			Centrifugal			
	Air flow rate	Nom.	m <sup>3</sup> /min	70.2	109.8	126	
	Discharge direction			Horizontal			
	External static pressure	Nom.	Pa	50	60	72	
Max.		Pa	100	150			
Fan motor	Drive			Direct drive	Belt drive		
Sound power level	Cooling	Nom.	dBA	63	66	69	
Compressor	Type			Hermetically sealed scroll compressor			
	Quantity			1			
	Model			JT140BF-YE	JT212DA-YE	JT265DA-YE	
	Speed			rpm			
	Oil	Charged volume	l	1.5	2.7		
Operating Range	Water side	Cooling	Min.	°CDB	-10		
			Max.	°CDB	21		
	Air side	Cooling	Min.	°CDB	-10 (4)		
			Max.	°CDB	43		
Refrigerant	Type			R-407C			
	Control			Thermostatic expansion valve			
	Circuits	Quantity		1			
Refrigerant circuit	Charge		kg	2.1	3.9	4.7	
	N2 holding charge			No			
Refrigerant oil	Type			Idemitsu FVC68D			
	Evaporator water inlet/outlet			FBSP 1"			
Piping connections	Evaporator water drain			Field installation			

## 2 Specifications

2-1 Technical Specifications			EUWAC5FBZW1	EUWAC8FBZW1	EUWAC10FBZW1
Safety devices	Item	01	High pressure switch		
		02	Low pressure switch		
		03	Evaporating temperature protection		
		04	Discharge temperature protector		
		05	Outlet water temperature protection		
		06	Compressor motor overcurrent relay		
		07	Fan thermal protector		
		08	Anti-recycling and guard timer		
		09	DDC with electronic temperature control		
		10	Reverse phase protector		
		11	Internal fuses		

2-2 Electrical Specifications				EUWAC5FBZW1	EUWAC8FBZW1	EUWAC10FBZW1
Compressor	Phase			3~		
	Voltage		V	400		
	Voltage range	Min.	%	-10		
		Max.	%	10		
	Starting current		A	60.0	95.0	130
	Nominal running current (RLA)		A	6.70	10.7	13.5
	Maximum running current		A	10.0	18.0	22.0
	Starting method			Direct on line		
Recommended fuses			-			
Power supply	Name			W1		
	Phase			3N~		
	Frequency		Hz	50		
	Voltage		V	400		
	Voltage range	Min.	%	-10		
		Max.	%	10		
Unit	Starting current		A	81	110	145
	Current	Zmax	Text	0.15	0.06	0.04
	Nominal running current (RLA)	Cooling	A	11.3	14.0	16.8
	Maximum running current		A	16.8	21.4	25.5
	Recommended fuses according to IEC standard 269-2			3 x 25gG	3 x 32gG	
Fans	Quantity			1		
	Nominal running current (RLA)		A	4.6	3.3	
	Maximum running current		A	6.8	3.4	3.5
	Starting current - DOL		A	20.7	14.9	
Control circuit	Phase			1~		
	Voltage		V	230 (3)		
	Recommended fuses			Factory installed		
	Crankcase heater (E1/2HC)		W	33	50	

### Notes

- 1 All values are valid for external static pressure of: 50Pa (5HP); 60Pa (8HP); 72Pa (10HP); for 8 & 10HP, a factory pulley setting of 0 turns open.
- 2 5HP fan is a single phase motor
- 3 Control circuit voltage: 24AC (supplied by factory installed transformers)
- 4 with OPZL

### 3 Options

#### 3 - 1 Options

##### EUWAC-FBZW1

**Optional equipment for EUWAC-FBZ**  
Horse Power: 5~10

**Modelnumber**

EUWAC5FBZW1 (on)  
EUWAC8FBZW1 (on)  
EUWAC10FBZW1 (on)

Option number	Option description	Decimal code	Unit size			Availability
			5FBZW1	8FBZW1	10FBZW1	
	Standard unit	–	•	•	•	
	<b>Available options</b>	1st digit				
ZH	chilled water temp down to -5°C	12	•	•	•	factory mounted
ZL	chilled water temp down to -10°C	24	•	•	•	factory mounted
	<b>Available kits</b>					
EKAC10C	Address card for connection to BMS or Remote user interface		•	•	•	kit
EKRUMCA	Remote installed user interface		•	•	•	kit

#### NOTES

- std = standard on unit
- = available  
• x = available and a quantity of x is needed for this unit size  
– = not available
- Impossible option combination : ZH + ZL
- (on) = option number
- 1st digit (on) = sum of 1st digit decimal code and this summation transferred to a 36 character system
- To install EKRUMCA => EKAC10C needs to be installed on the unit.
- EKAC10C : this address card allows direct connection to MODBUS BMS system.

3TW60289-5

## 4 Control systems

### 4 - 1 Control Systems

#### Direct and user parameters

The digital controller provides direct and user parameters. The direct parameters are important for the everyday usage of the unit, e.g. to adjust the temperature setpoint or to consult actual operational information. The user parameters on the contrary provide advanced features such as adjusting time delays or disabling the buzzer. Each parameter is defined by a code and a value. For example, the parameter used to select local or remote on/off control has code h7 and value 1 or 0.

#### User interface EUWAC5-10FZ

The digital controller consists of a numeric display, four labelled keys which you can press and four LEDs providing extra user information.

#### Digital controller

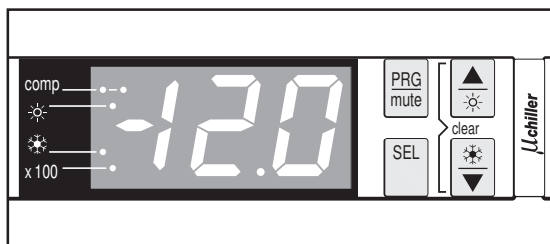

Keys provided on the controller.

Each key, except for the lower left key, combines two functions: **PRG** / **mute**, **▲** / **☀** and **☀** / **▼**. The function carried out when the user presses one of these keys depends on the status of the controller and the unit at that specific moment.



Key, to enter the scroll list of user parameters, to confirm a parameter modification and to return to normal operation.



Key, to de-activate the buzzer in the case of an alarm.



Key, to scroll through the list of direct or user parameters or to raise a setting.



Key, to enter the scroll list of direct parameters or to switch between a parameter's code and its value.



Key, to start the unit in cooling mode or to switch the unit off when cooling mode is active.



Key, to scroll through the list of direct or user parameters or to lower a setting.

LEDs provided on the controller:

The controller provides five LEDs one of which, the left **comp** LED, is not used.



LED, indicates the status of the compressor. The LED does not light up when the compressor is not active, blinks when the compressor cannot start up although extra load is requested (e.g. timer active) and lights up permanently when the compressor is active.



LED, indicates that cooling mode is active.



LED, indicates that the value on the numeric display should be multiplied by 100.

#### Note:

- Temperature readout tolerance:  $\pm 1^{\circ}\text{C}$ .
- Legibility of the numeric display may decrease in direct sunlight.



## 5 Capacity tables

### 5 - 1 Cooling Capacity Tables

#### CC - 10 HP

Ta/LWE	-10.00	-8.00	-6.00	-4.00	-2.00	0.00	2.00	4.00	7.00	10.00	16.00	21.00
20.00	14.3	15.9	17.5	19.2	20.8	22.4	24.0	25.6	28.1	30.5	35.4	39.4
25.00	13.4	15.0	16.5	18.1	19.6	21.2	22.8	24.3	26.6	29.0	33.6	37.5
30.00	12.6	14.0	15.5	17.0	18.5	20.0	21.5	23.0	25.2	27.4	31.9	35.6
35.00	11.7	13.1	14.5	15.9	17.4	18.8	20.2	21.6	<b>23.8</b>	25.9	30.2	33.7
40.00					16.2	17.6	18.9	20.3	22.3	24.4	28.4	31.8
43.00								19.5	21.5	23.4	27.4	30.7

#### CC - 8 HP

Ta/LWE	-10.00	-8.00	-6.00	-4.00	-2.00	0.00	2.00	4.00	7.00	10.00	16.00	21.00
20.00	9.44	10.8	12.2	13.6	15.0	16.4	17.7	19.1	21.2	23.3	27.4	30.9
25.00	8.67	10.0	11.4	12.8	14.1	15.5	16.9	18.2	20.3	22.3	26.4	29.8
30.00	7.89	9.24	10.6	11.9	13.3	14.6	16.0	17.3	19.3	21.3	25.4	28.7
35.00	7.12	8.45	9.77	11.1	12.4	13.7	15.1	16.4	<b>18.4</b>	20.4	24.3	27.7
40.00					11.6	12.9	14.2	15.5	17.4	19.4	23.3	26.6
43.00								14.9	16.9	18.8	22.7	25.9

#### CC - 5 HP

Ta/LWE	-10.00	-8.00	-6.00	-4.00	-2.00	0.00	2.00	4.00	7.00	10.00	16.00	21.00
20.00	6.36	7.26	8.15	9.04	9.93	10.8	11.7	12.6	13.9	15.3	18.0	20.2
25.00	5.78	6.65	7.52	8.39	9.25	10.1	11.0	11.9	13.2	14.5	17.1	19.3
30.00	5.19	6.04	6.88	7.73	8.58	9.43	10.3	11.1	12.4	13.7	16.2	18.3
35.00	4.60	5.42	6.25	7.08	7.90	8.73	9.55	10.4	<b>11.6</b>	12.9	15.3	17.4
40.00					7.23	8.03	8.83	9.64	10.8	12.1	14.5	16.5
43.00								9.19	10.4	11.6	13.9	15.9

3TW55052-1B

#### SYMBOLS

CC	: Cooling capacity (kW)
PI	: Power input (kW)
LWE	: Leaving Water Evaporator temperature (°C)
Ta	: Air suction temperature (°C)

#### NOTES

- Cooling capacity (CAP)**  
Capacity is according to Eurovent rating standard 6/C/003-2003 and valid for chilled water range  $\Delta t = 3 - 8^\circ\text{C}$ .
- Power input (kW)**  
Power input is total input according to Eurovent rating standard 6/C/003-2003: Compressor + fans + control circuit.
- External static pressure**  
Values for CC and PI are for a nominal ESP, at a factory fan motor pulley setting of 0 turns open:  
5 HP → ESP 50 Pa  
8 HP → ESP 60 Pa  
10 HP → ESP 72 Pa

# 5 Capacity tables

## 5 - 1 Cooling Capacity Tables

### PI - 10 HP

Ta/LWE	-10.00	-8.00	-6.00	-4.00	-2.00	0.00	2.00	4.00	7.00	10.00	16.00	21.00
20.00	6.21	6.36	6.52	6.67	6.82	6.97	7.12	7.27	7.50	7.72	8.15	8.50
25.00	6.81	6.96	7.11	7.27	7.42	7.57	7.72	7.87	8.10	8.32	8.76	9.11
30.00	7.53	7.68	7.83	7.99	8.14	8.29	8.44	8.60	8.82	9.05	9.49	9.8
35.00	8.37	8.53	8.68	8.83	8.99	9.14	9.29	9.44	<b>9.67</b>	9.9	10.3	10.7
40.00					10.0	10.1	10.3	10.4	10.6	10.9	11.3	11.7
43.00								11.1	11.3	11.5	12.0	12.3

### PI - 8 HP

Ta/LWE	-10.00	-8.00	-6.00	-4.00	-2.00	0.00	2.00	4.00	7.00	10.00	16.00	21.00
20.00	4.79	4.90	5.02	5.14	5.25	5.37	5.49	5.60	5.77	5.94	6.28	6.55
25.00	5.36	5.48	5.60	5.71	5.83	5.95	6.06	6.18	6.35	6.52	6.86	7.13
30.00	5.99	6.11	6.23	6.34	6.46	6.58	6.69	6.81	6.98	7.15	7.49	7.77
35.00	6.68	6.79	6.91	7.03	7.14	7.26	7.38	7.49	<b>7.66</b>	7.84	8.18	8.46
40.00					7.88	8.00	8.12	8.23	8.41	8.58	8.92	9.20
43.00								8.70	8.88	9.05	9.39	9.68

### PI - 5 HP

Ta/LWE	-10.00	-8.00	-6.00	-4.00	-2.00	0.00	2.00	4.00	7.00	10.00	16.00	21.00
20.00	3.51	3.58	3.65	3.73	3.80	3.87	3.94	4.02	4.12	4.23	4.45	4.62
25.00	3.85	3.92	3.99	4.07	4.14	4.21	4.28	4.35	4.46	4.57	4.79	4.96
30.00	4.21	4.28	4.35	4.43	4.50	4.57	4.64	4.71	4.82	4.93	5.15	5.32
35.00	4.59	4.66	4.73	4.81	4.88	4.95	5.02	5.09	<b>5.20</b>	5.31	5.53	5.71
40.00						5.35	5.42	5.50	5.60	5.71	5.93	6.11
43.00								5.75	5.86	5.96	6.18	6.36

3TW55052-1B

### SYMBOLS

- CC : Cooling capacity (kW)
- PI : Power input (kW)
- LWE : Leaving Water Evaporator temperature (°C)
- Ta : Air suction temperature (°C)

### NOTES

- 1 **Cooling capacity (CAP)**  
Capacity is according to Eurovent rating standard 6/C/003-2003 and valid for chilled water range Dt = 3 - 8°C.
- 2 **Power input (kW)**  
Power input is total input according to Eurovent rating standard 6/C/003-2003: Compressor + fans + control circuit.
- 3 **External static pressure**  
Values for CC and PI are for a nominal ESP, at a factory fan motor pulley setting of 0 turns open:  
5 HP → ESP 50 Pa  
8 HP → ESP 60 Pa  
10 HP → ESP 72 Pa

# 6 Dimensional drawings

## 6 - 1 Dimensional Drawings

### EUWAC5FZW

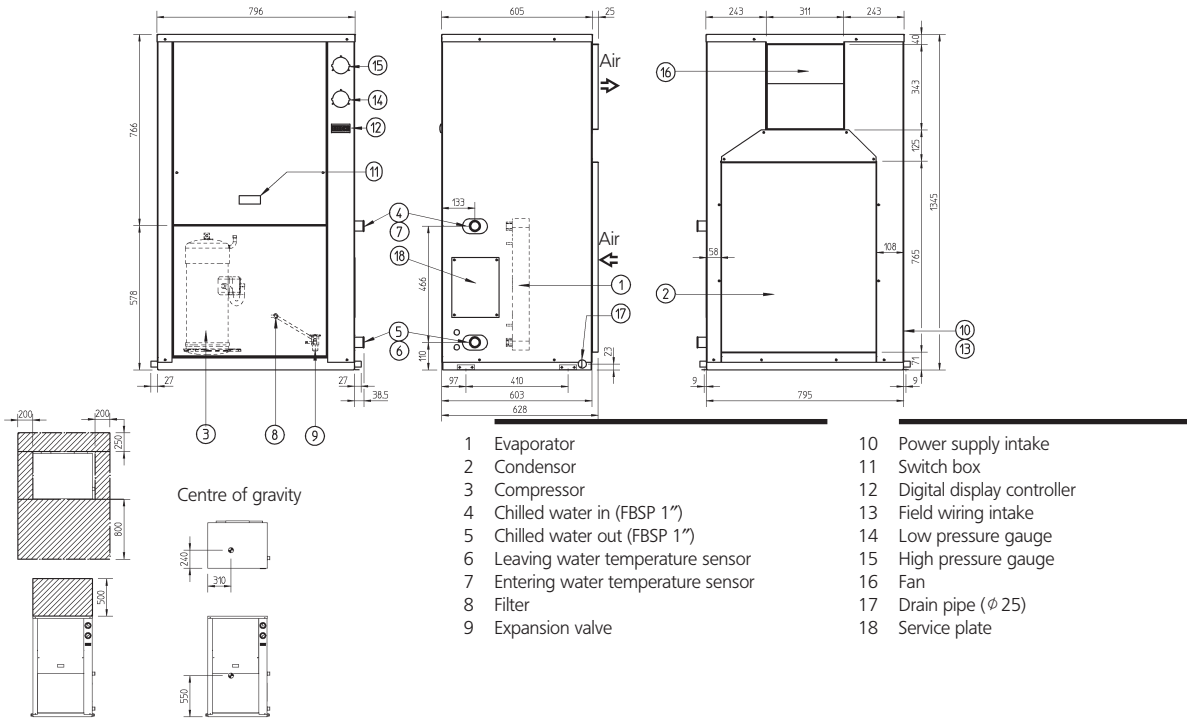

- 1 Evaporator
- 2 Condenser
- 3 Compressor
- 4 Chilled water in (FBSP 1")
- 5 Chilled water out (FBSP 1")
- 6 Leaving water temperature sensor
- 7 Entering water temperature sensor
- 8 Filter
- 9 Expansion valve
- 10 Power supply intake
- 11 Switch box
- 12 Digital display controller
- 13 Field wiring intake
- 14 Low pressure gauge
- 15 High pressure gauge
- 16 Fan
- 17 Drain pipe (φ 25)
- 18 Service plate

Required space around the unit for service and air intake

3TW55054-1C

### EUWAC8-10FZW

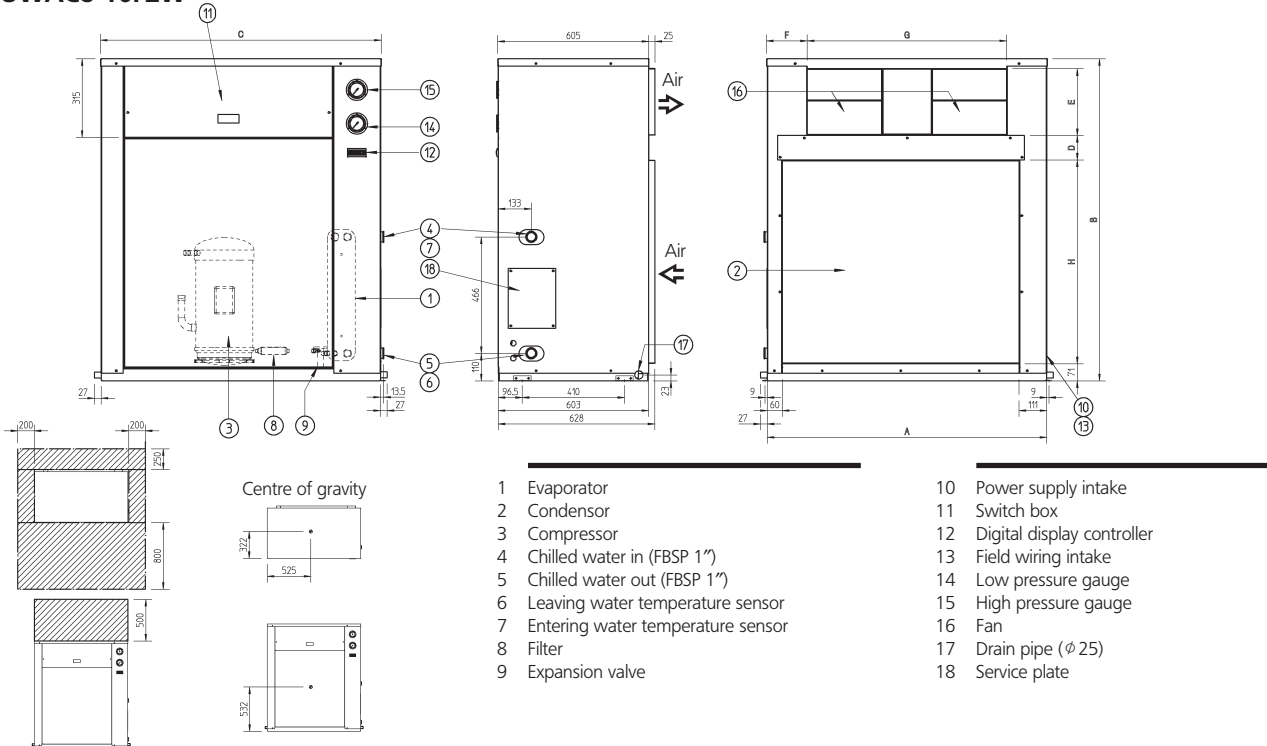

- 1 Evaporator
- 2 Condenser
- 3 Compressor
- 4 Chilled water in (FBSP 1")
- 5 Chilled water out (FBSP 1")
- 6 Leaving water temperature sensor
- 7 Entering water temperature sensor
- 8 Filter
- 9 Expansion valve
- 10 Power supply intake
- 11 Switch box
- 12 Digital display controller
- 13 Field wiring intake
- 14 Low pressure gauge
- 15 High pressure gauge
- 16 Fan
- 17 Drain pipe (φ 25)
- 18 Service plate

Required space around the unit for service and air intake

Item	A	B	C	D	E	F	G	H
8HP	1122	1290	1125	98	267	163	800	815
10HP	1272	1395	1275	127	292	170	936	857

3TW55064-1C

# 7 Piping diagrams

## 7 - 1 Piping Diagrams

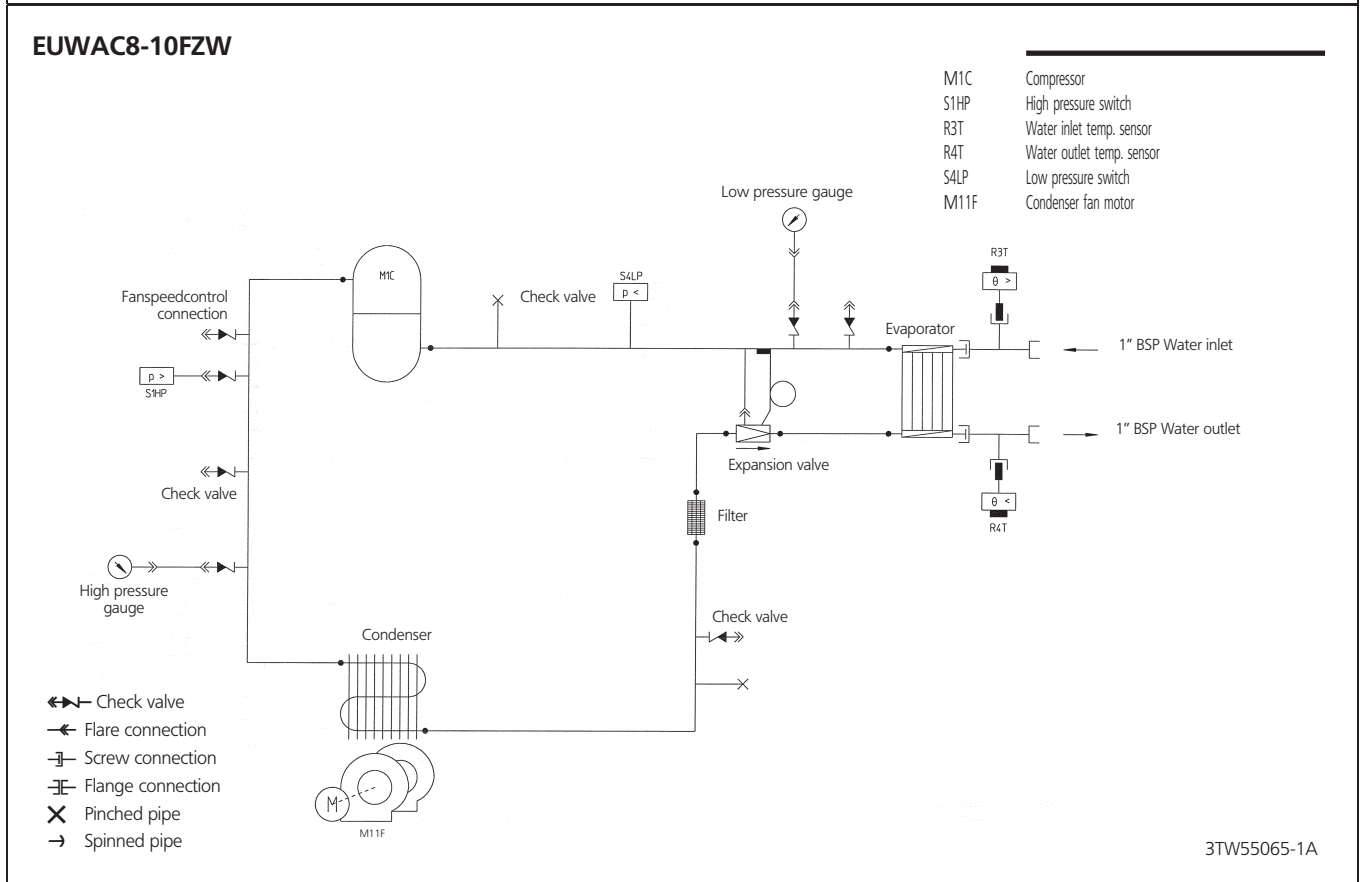
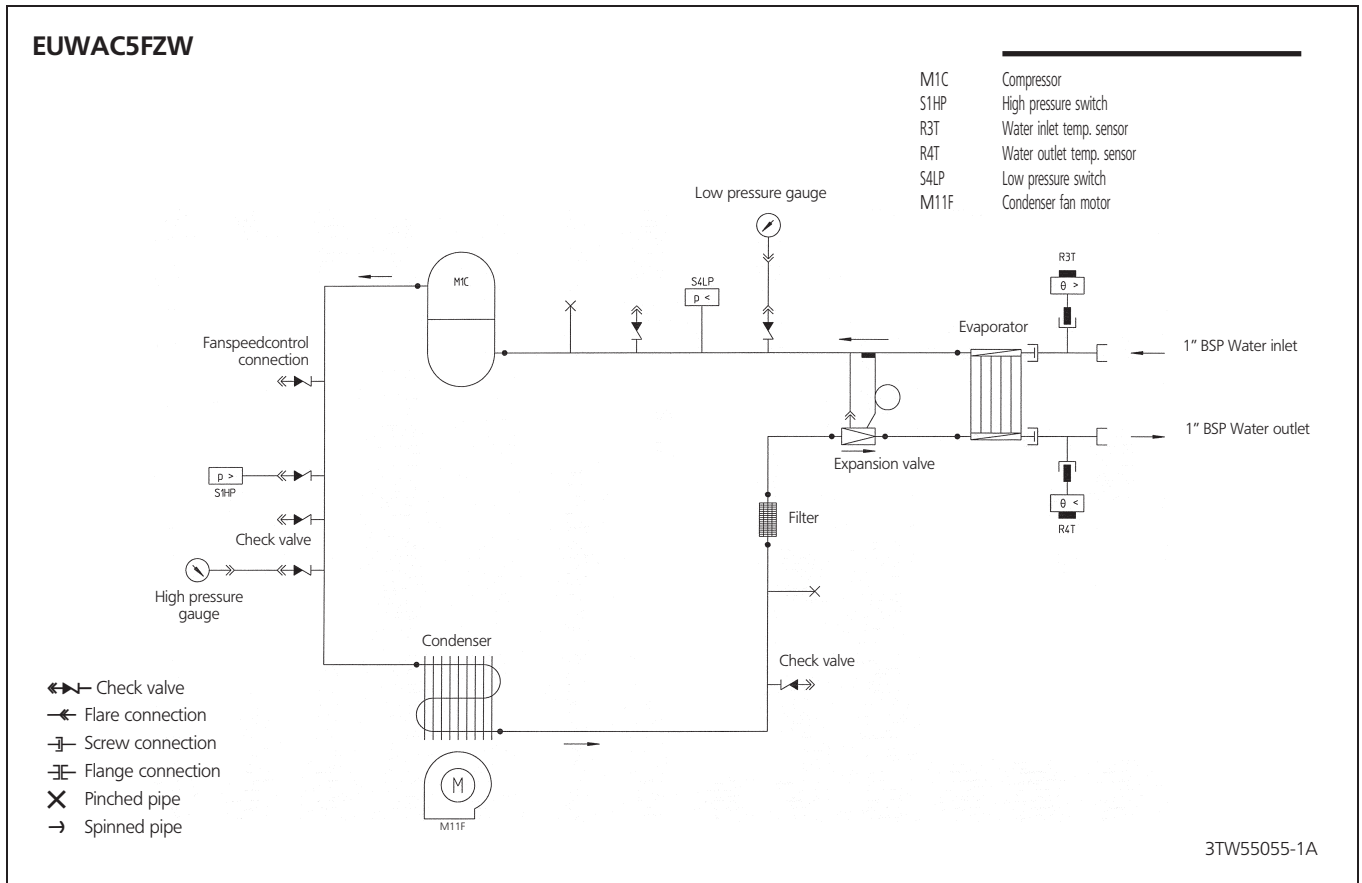

# 8 Wiring diagrams

## 8 - 1 Wiring Diagrams - Three Phase

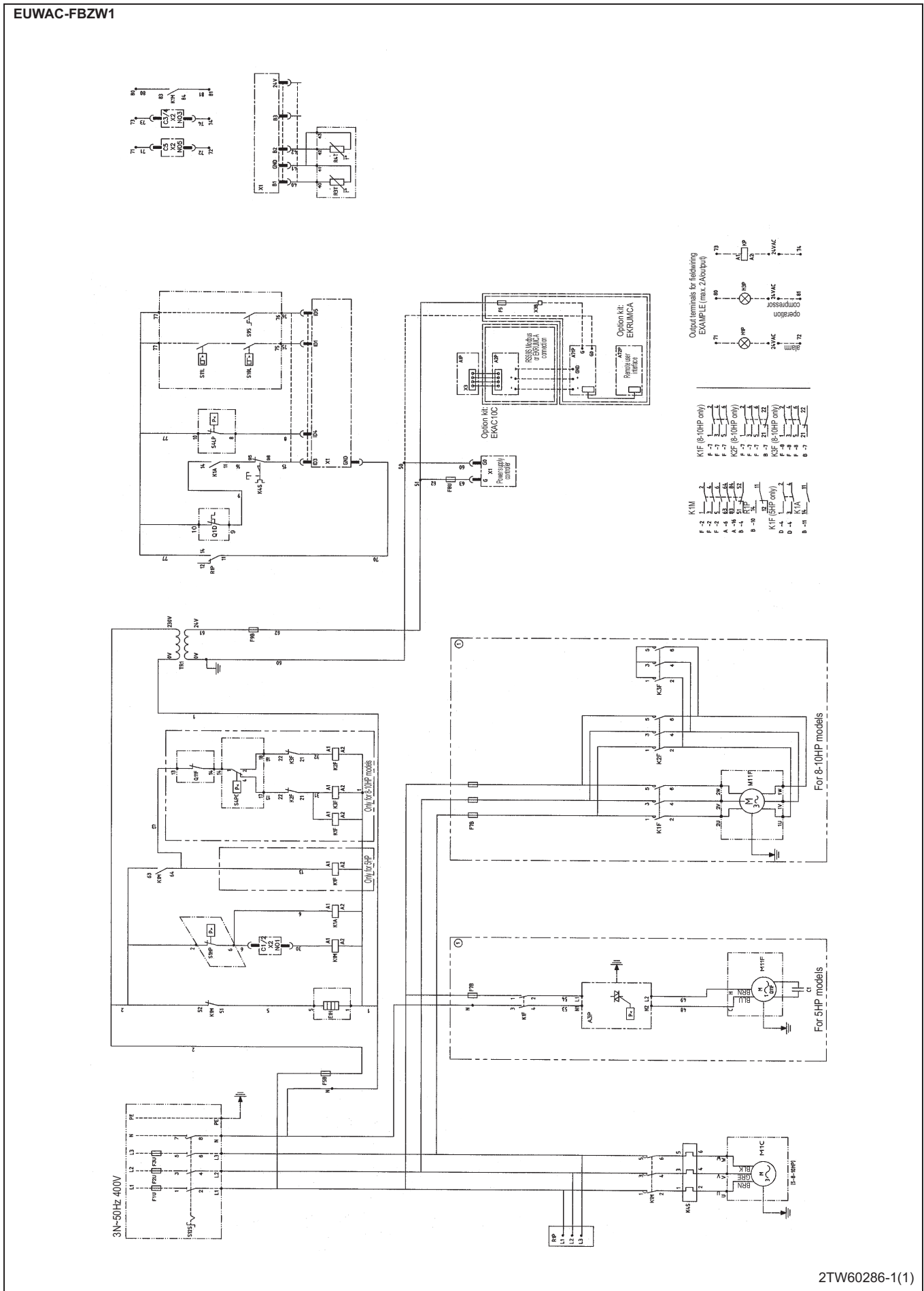

2TW60286-1(1)

# 8 Wiring diagrams

## 8 - 1 Wiring Diagrams - Three Phase

### EUWAC-FBZW1

	Not standard included	
	Not possible as option	Possible as option
Obligatory	#	##
Not obligatory	*	**

Recommended fuses gL/gG (aM also admitted) according to IEC standard 269-2 (F11,F2U,F3U = gL/gG)

Fuses + overcurrent	400V		
	5HP	8HP	10HP
F1U, F2U, F3U	25gG	32gG	32gG
F5B	1A	1A	1A
F7B	10A	6A	6A
F9B	1A	1A	1A
F8U	315mAT	315mAT	315mAT
F5	250mAT	250mAT	250mAT
K4S	10A	18A	22A





Digital inputs	Digital outputs (relays)	Analog inputs
X1 <ID1-GND> flow switch	X2 <C1/2-NO1> compressor on	X1 <B1-GND> inlet water t°
X1 <ID2-GND>	X2 <C1/2-NO2> --	X1 <B2-GND> outlet water t°
X1 <ID3-GND> high pressure switch + discharge protector + overcurrent	X2 <C3/4-NO3> voltage free contact for pump	X1 <B3-GND> --
X1 <ID4-GND> low pressure switch	X2 <C3/4-NO4> --	Analog output
X1 <ID5-GND> remote On/Off	X2 <C5-NO5> alarm voltage free contact	X1 <Y-GND> --

X1	connector in terminal unit for digital inputs, analog inputs and for power supply controller	Q1D	discharge thermal protector	F1U,F2U,F3U #	main fuses for the unit
		PE	main earth terminal	E1H	crankcase heater
X2	connector for digital outputs in terminal unit	M1C	compressor motor	C1	capacitor for fanmotor
TR1	transfo 230V -> 24V for supply of controllers	M11F	Triac	A72P **	PCB: remote user interface
S12S #	main isolator switch	KP *	pumpcontactor	A71P **	PCB: power supply card
S11L #	contact that closes if pump is working	K2F	contactors for speedselection fanmotor (low)	A3P	PCB: fanspeedcontroller
S10L #	flowswitch	K1F, K3F	contactors for speedselection fanmotor (high)	A2P	PCB: address card
S9S *	switch for remote start/stop or dual setpoint	K1A	auxiliary contactor for high pressure	A1P	PCB: terminal unit
S4PC	head pressure control pressure switch for fanspeed control	K4S	overcurrent relay	BRN: brown	
		K1M	compressor contactor	BLK: black	
S4LP	low pressure switch	H3P *	indication lamp operation compressor	BLU: blue	
S1HP	high pressure switch	H1P *	indication lamp alarm	GRE: grey	
S4T	outlet water temperature sensor	F5 ##	surge proof fuse		
R3T	inlet water temperature sensor	F8U	surge proof fuse		
R1P	reverse phase protector	F7B	fuse for fanmotor		
Q11F	thermal protector fan	F5B,F9B	fuse for the control circuit / secondary of TR1		

2TW60286-1(2)

### NOTES

1. ⚡ : Terminal 1, ~ : Wire 2, --- : Field wiring to be in accordance with the local electrical regulations, --- : Earth wiring,

 : Option,  : Wiring dependent on model,  : PCB-display,  : outside switchbox

2. If compressor rotates reversely, it may be damaged

3. Optional:



- ZH = Glycol application chilled water temperature down to -5°C
- ZL = Glycol application chilled water temperature down to -10°C
- EKAC10C = address card for Modbus or remote user interface
- EKRUMCA = remote user interface

## 9 Sound data

### 9 - 1 Sound Power Spectrum

		Sound power Lw per Octave band (dB)							Total (dBA)
		63	125	250	500	1000	2000	4000	
EUWAC5FZW	Lw	65	66	65	59	51	44	36	63
	Lwd	85	70	67	70	67	66	64	75
EUWAC8FZW	Lw	75	70	66	61	56	48	40	66
	Lwd	70	70	68	65	66	62	60	72
EUWAC10FZW	Lw	73	70	69	64	58	52	48	69
	Lwd	77	69	68	69	66	66	62	74

4TW55057-1A

Compact unit with ducts Sound power level for the housing		Lw
Compact unit with ducts Sound power level for the proportion of sound radiated by the openings of the ducts		Lw

#### NOTES

- 1 Data valid at nominal operation conditions with external static pressure of  
 5 HP → ESP 50 Pa  
 8 HP → ESP 60 Pa  
 10 HP → ESP 72 Pa  
 And a factory pulley setting of 0 turns open
- 2 Testing according to ENV12102

# 10 Installation

## 10 - 1 Water Charge, Flow and Quality

Be sure the water quality is in accordance with the specifications below:

ITEMS	Cooled water		Tendency if out of criteria
	Circulating water (below 20°C)	Water supply	
Items to be controlled:			
- pH at 25°C	6.8 - 8.0	6.8 - 8.0	Corrosion + scale
- Electrical conduct			
(mS/m) at 25°C	Below 40	Below 30	Corrosion + scale
(μS/cm) at 25°C	—	—	Corrosion + scale
- Chloride ion (mg Cl <sup>-</sup> /l)	Below 50	Below 50	Corrosion
- Sulfate ion (mg SO <sub>4</sub> <sup>2-</sup> /l)	Below 50	Below 50	Corrosion
- M-alkalinity (pH 4.8) (mg SO <sub>3</sub> /l)	Below 50	Below 50	Scale
- Total hardness (mg CaCO <sub>3</sub> /l)	Below 70	Below 70	Scale
- Calcium hardness (mg CaCO <sub>3</sub> /l)	Below 50	Below 50	Scale
- Silica ion (mg SiO <sub>2</sub> /l)	Below 30	Below 30	Scale
Items to be referred to:			
- Iron (mg Fe/l)	Below 1.0	Below 0.3	Corrosion + scale
- Copper (mg Cu/l)	Below 1.0	Below 0.1	Corrosion
- Sulfite ion (mg S <sup>2-</sup> /l)	Not detectable	Not detectable	Corrosion
- ammonium ion (mg NH <sub>4</sub> <sup>+</sup> /l)	Below 1.0	Below 0.1	Corrosion
- Remaining chloride (mg Cl/l)	Below 0.3	Below 0.3	Corrosion
- Free carbide (mg SO <sub>2</sub> /l)	Below 4.0	Below 4.0	Corrosion
- Stability index	—	—	Corrosion + scale



Names, definitions and units are according to JIS K 0101. Units and figures between brackets are old units published as reference only.

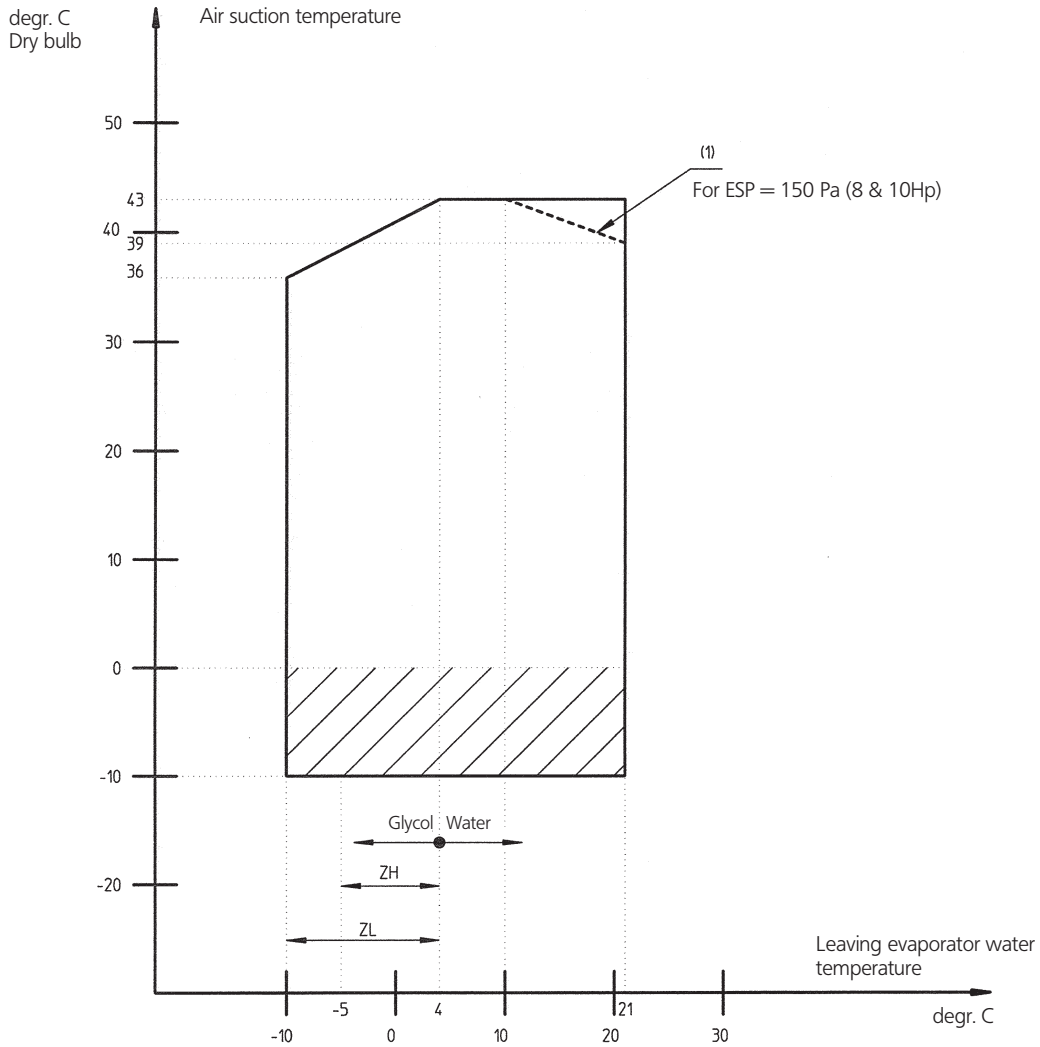

# 11 Operation range

## 11 - 1 Operation Range



-  Standard operation
-  Protection watercircuit against freezing

Note for 8-10HP: operation range is valid for a pulley setting of 0 turns open (factory setting)

4TW55053-1A

## 12 Hydraulic performance

### 12 - 1 Water Pressure Drop Curve Evaporator

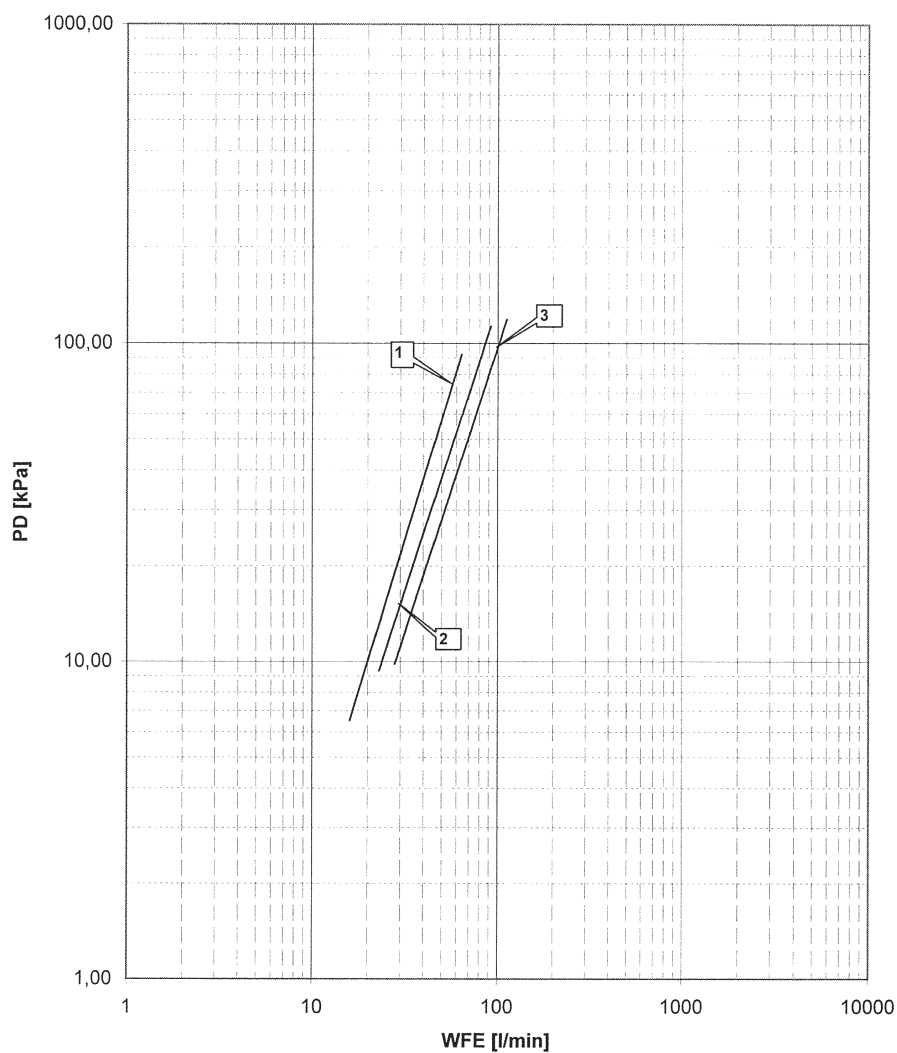

PD : Water pressure drop through the unit  
 WF : Evaporator waterflow rate

- 1 EUWAC5FZW
- 2 EUWAC8FZW
- 3 EUWAC10FZW

**Warning:** Selecting a flow outside the curves can cause damage to or malfunction of the unit. See also minimum and maximum allowed water flowrate in the technical specifications.

4TW55059-2A

# 13 Aeraulic performance

## 13 - 1 Available external static pressure

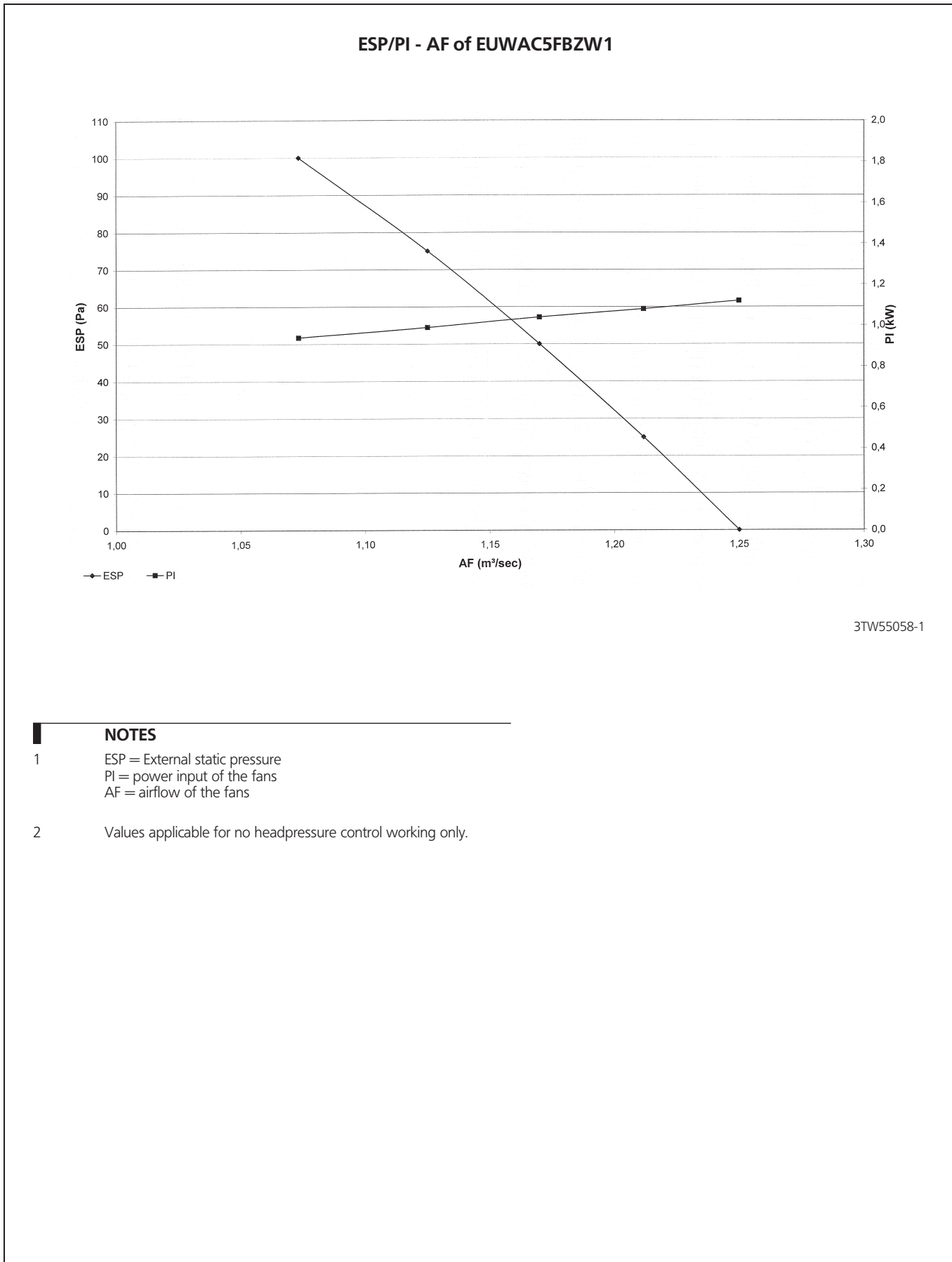

## 13 Aeraulic performance

### 13 - 1 Available external static pressure

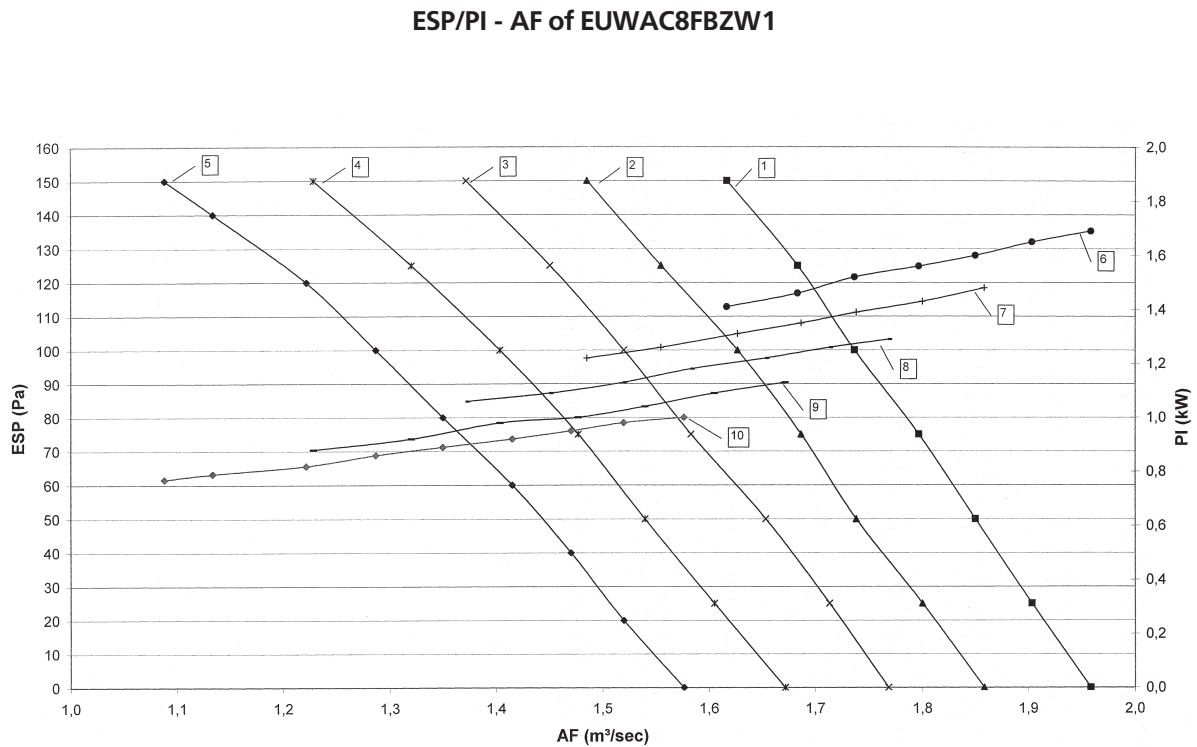

3TW55068-1

1. ESP with pulley closed
2. EPS with pulley 1 turn open
3. ESP with pulley 2 turns open
4. ESP with pulley 3 turns open
5. ESP with pulley 4 turns open
6. PI with pulley closed
7. PI with pulley 1 turn open
8. PI with pulley 2 turns open
9. PI with pulley 3 turns open
10. PI with pulley 4 turns open

#### NOTES

1. ESP = External static pressure  
PI = power input of the fans  
AF = airflow of the fans
2. Values applicable for no headpressure control working only.
3. Factory setting is "pulley closed".

# 13 Aeraulic performance

## 13 - 1 Available external static pressure

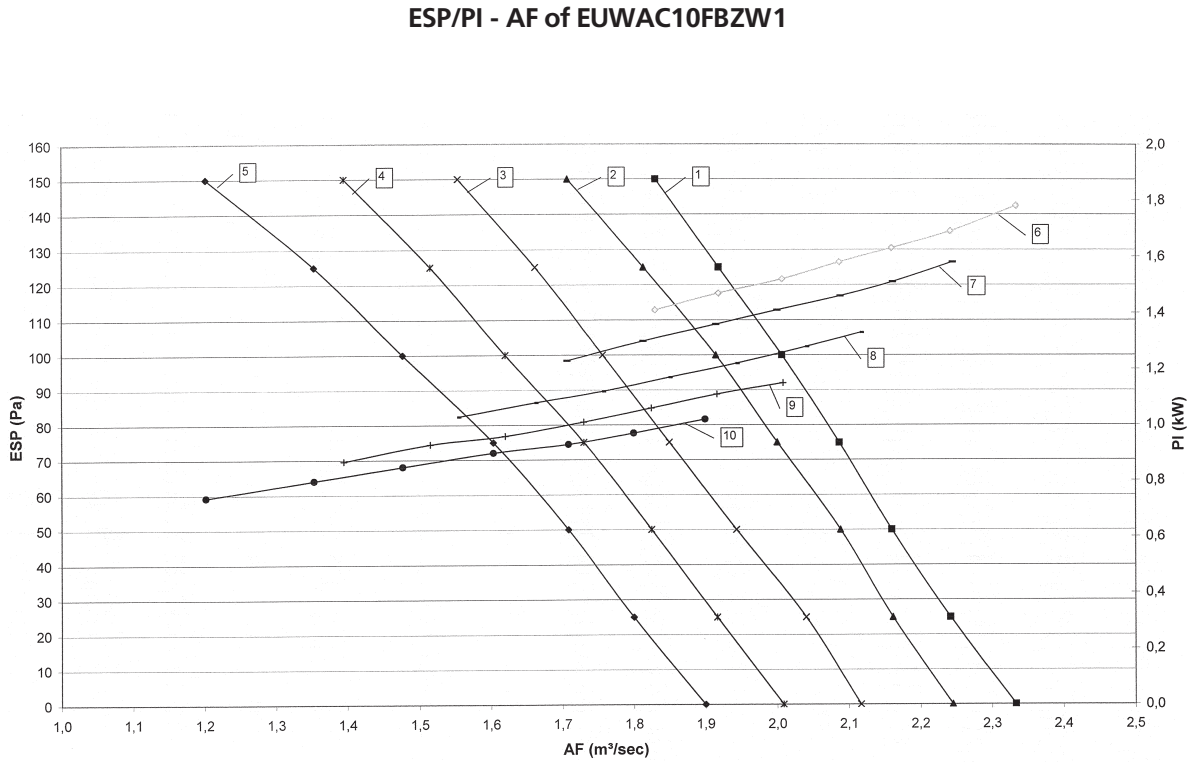

3TW55078-1

1. ESP with pulley closed
2. EPS with pulley 1 turn open
3. ESP with pulley 2 turns open
4. ESP with pulley 3 turns open
5. ESP with pulley 4 turns open
6. PI with pulley closed
7. PI with pulley 1 turn open
8. PI with pulley 2 turns open
9. PI with pulley 3 turns open
10. PI with pulley 4 turns open

### NOTES

1. ESP = External static pressure  
PI = power input of the fans  
AF = airflow of the fans
2. Values applicable for no headpressure control working only.
3. Factory setting is "pulley closed".





Daikin's unique position as a manufacturer of air conditioning equipment, compressors and refrigerants has led to its close involvement in environmental issues. For several years Daikin has had the intention to become a leader in the provision of products that have limited impact on the environment. This challenge demands the eco design and development of a wide range of products and an energy management system, resulting in energy conservation and a reduction of waste.



The present publication is drawn up by way of information only and does not constitute an offer binding upon Daikin Europe N.V. Daikin Europe N.V. has compiled the content of this publication to the best of its knowledge. No express or implied warranty is given for the completeness, accuracy, reliability or fitness for particular purpose of its content and the products and services presented therein. Specifications are subject to change without prior notice. Daikin Europe N.V. explicitly rejects any liability for any direct or indirect damage, in the broadest sense, arising from or related to the use and/or interpretation of this publication. All content is copyrighted by Daikin Europe N.V.

Daikin products are distributed by:



Daikin Europe N.V. is participating in the EUROVENT Certification Programme. Products are as listed in the EUROVENT Directory of Certified Products.