



Fan Coil Units

Technical Data

4-way blow ceiling mounted cassette



ECDEN12-400

FWF-BT/BF



Fan Coil Units

Technical Data

4-way blow ceiling mounted cassette



ECDEN12-400

FWF-BT/BF

FWF-BT/BF

I	Roundflow cassette	
	FWF-BT	3
	FWF-BF	21

1

2

TABLE OF CONTENTS

FWF-BT

1	Features	4
2	Specifications	5
	Technical Specifications	5
	Electrical Specifications	5
3	Electrical data	6
	Electrical Data	6
4	Safety device settings	7
	Safety Device Settings	7
5	Options	8
	Options	8
6	Capacity tables	10
	Cooling Capacity Tables	10
	Heating Capacity Tables	11
7	Dimensional drawings	12
	Dimensional Drawings	12
	Dimensional Drawings with Accessories	13
8	Centre of gravity	14
	Centre of Gravity	14
9	Piping diagrams	15
	Piping Diagrams	15
10	Wiring diagrams	16
	Wiring Diagrams - Single Phase	16
11	Sound data	17
	Sound Power Spectrum	17
	Sound Pressure Spectrum	18
12	Hydraulic performance	19
	Water Pressure Drop Curve Evaporator	19

1 Features

- Modern style decoration panel in white (RAL9010)
- Compact casing (570mm in width and depth) enables unit to fit flush into ceilings and match standard architectural modules, without cutting ceiling tiles
- Comfortable horizontal auto swing ensures draughtfree operation and prevents ceiling soiling
- Fresh air intake for healthy living
- Possibility to shut 1 or 2 flaps for easy installation in corners
- Standard drain pump with 750mm lift



1

1

2 Specifications

2-1 Technical Specifications				FWF02BT	FWF03BT	FWF04BT	FWF05BT
Cooling capacity	Total capacity	Super high	kW	2.0 (1)	3.2 (1)	4.2 (1)	5.2 (1)
		High	kW	1.7 (1)	2.8 (1)	3.3 (1)	4.0 (1)
		Low	kW	1.5 (1)	2.5 (1)		2.9 (1)
	Sensible capacity	Super high	kW	1.5 (1)	2.0 (1)	2.8 (1)	3.5 (1)
		High	kW	1.3 (1)	1.7 (1)	2.1 (1)	2.7 (1)
		Low	kW	1.1 (1)	1.4 (1)		1.8 (1)
Heating capacity	2-Pipe	Super high	kW	2.9 (2)	4.0 (2)	5.4 (2)	6.7 (2)
		High	kW	2.6 (2)	3.4 (2)	4.1 (2)	5.3 (2)
		Low	kW	2.3 (2)	2.8 (2)		3.6 (2)
Power input	Super high	W	74		90	118	
	High	W	67		70	89	
	Low	W	60		55	62	
Casing	Material			Galvanised steel plate			
Dimensions	Unit	Height	mm	285			
		Width	mm	575			
		Depth	mm	575			
Weight	Unit	kg	19				
Heat exchanger	Rows	Quantity	2				
	Fin pitch		mm	1.5			
Water pressure drop	Cooling	kPa	6	19	31	42	
	Heating	kPa	6	19	31	42	
Fan	Type		Turbo fan				
	Quantity		1				
	Air flow rate	High	m ³ /h	468	660		876
		Medium	m ³ /h	390	486		648
Low		m ³ /h	318		420		
Fan motor	Speed	Steps	3				
	Model		QTS32C15M				
Sound power level	Super high	dBA	44	50		55	
	High	dBA	40	44		49	
	Low	dBA	36		42		
Sound pressure level	Super high	dBA	31	40		45	
	High	dBA	27	33		39	
	Low	dBA	26		30		
Insulation material			Foamed polystyrene / foamed polyethylene				

Standard Accessories : Screws;

Standard Accessories : O ring;

Standard Accessories : Insulation;

Standard Accessories : Washer for hanger bracket;

Standard Accessories : Clamp for drain hose;

Standard Accessories : Installation and operation manual;

Standard Accessories : Installation guide;

Standard Accessories : Drain hose;

2-2 Electrical Specifications			FWF02BT	FWF03BT	FWF04BT	FWF05BT
Power supply	Phase		1~			
	Frequency	Hz	50			
	Voltage	V	220-440			

Notes

(1) Cooling: air 27°CDB, 19°CWB; entering water 7°C; leaving water 12°C

(2) Heating: 2 pipe: air 20°CDB; entering water 50°C

(3) Do not let water of less than 5°C or more than 50°/70°C enter the unit, this may damage the unit

(4) Height includes switch box

3 Electrical data

3 - 1 Electrical Data

FWF-BT-BF

UNITS					POWER SUPPLY		IFM		INPUT (W)	
MODEL	TYPE	Hz	VOLTAGE RANGE	VOLTAGE LIMITS	MCA	MFA	kW	FLA	COOLING	HEATING
FWF02BT	V1	50	220-240	MAX. 264 MIN. 198	0.6	16	0.055	0.5	74	74
FWF03BT					0.6	16	0.055	0.5	74	74
FWF04BT					0.7	16	0.055	0.6	90	90
FWF05BT					0.8	16	0.055	0.7	118	118
FWF02BF	V1	50	220-240	MAX. 242 MIN. 198	0.6	16	0.055	0.5	74	74
FWF03BF					0.6	16	0.055	0.5	74	74
FWF04BF					0.7	16	0.055	0.6	94	94
FWF05BF					0.8	16	0.055	0.7	121	121

Symbols:

- MCA : Min Circuit Amps (A)
- MFA : Max. Fuse Amps (See note 5)
- kW : FAN Motor Rated Output (kW)
- FLA : Full Load Amps (A)
- IFM : Indoor Fan Motor

NOTES

1. Voltage limits:
Units are suitable for use on electrical systems where voltage supplied to unit terminals is not below or above listed range limits.
2. Maximum allowable voltage unbalanced between phases is 2%.
3. MCA/MFA
MCA = 1.25 x FLA
MFA <= 4 x FLA
(Next lower standard fuse rating min. 16A)
4. Select wire size based on the MCA.
5. Instead of fuse, use Circuit Breaker.

4TW33041-2

1
3

4 Safety device settings

4 - 1 Safety Device Settings

FWF-BT-BF

		02	03	04	05
FWF-BF/BT	PC board fuse		250V 5A		
	Fan motor thermal fuse	°C	---		
	Fan motor thermal protector	°C	OFF: 130±5 ON: 83±20		

4TW33049-4

5 Options

5 - 1 Options

FWF-BT/BF

Options

Item	Model	FWF02-05B
1	Decoration Panel (RAL 9010 - grey sealings)	4-way blow BYFQ60B
2	Sealing member of air discharge outlet	KDBH44BA60
3	Panel spacer	KDBQ44B60
4	Long-life filter	KAFQ441BA60
5	Fresh air intake kit	Direct installation type KDDQ44XA60

Control system

Item	Model	FWF02-05B	
1	Remote control	Infrared	
		H/P	BRC7E530 (*12)
		C/O	BRC7E531 (*12)
	Wired	BRC315D7 (*1)	
2	Central remote control	DCS302CA51 (*2)	
2.1	Electrical box with earth terminal (3 blocks)	KJB311A	
3	Unified on/off controller	DCS301BA51 (*5)	
3.1	Electrical box with earth terminal (2 blocks)	KJB212A	
4	Schedule timer	DST301BA51 (*5)(*8)	
5	Wiring adapter for electrical appendices (1)	KRP2A52 (*4)(*8)	
6	Wiring adapter for electrical appendices (2)	KRP4AA53 (*4)(*8)	
7	Installation box for adapter PCB	KRP1BA101 (*9)	
8	Remote sensor	KRCS01-1	
10	Intelligent touch controller	DCS601C51C (*3)(*7)	
10.1	Electrical installation box	KJB411A	
11	Optional PCB for MOD-bus connection	EKFCMBCB7 (*4)(*8)	
12	2-way valve - On/Off	EKMV2C09B7 (*4)(*6)(*10)	
13	3-way valve - On/Off	EKMV3C09B7 (*4)(*6)(*10)	
14	Valve control PCB	EKR1C11	
15	Remote "On/Off" and "forced off" kit	EKROROA (*11)	

NOTES

- *1. Optional, electrical installation box with earth terminal KJB212A is required, if controller wires need to be installed in the wall.
- *2. Requires electrical installation box with earth terminal KJB311A.
- *3. Requires electrical installation box KJB411A.
- *4. Requires installation box KRP1BA101.
- *5. Requires electrical installation box with earth terminal KJB212A if built in the wall.
- *6. Requires valve control PCB EKR1C11.
- *7. I-touch:
 - Not allowed to use the i-touch for an installation with both fan coils and VRV® units.
 - Can not be used in combination with fan coil units, that use MOD bus communication.
 - No Airmet or telephone connection possible.
- *8. Only 1 of these 4 options can be installed on 1 indoor unit.
- *9. Max. 2 KRP1BA101 boxes can be mounted on the unit. Max. 1 PCB can be mounted in 1 KRP1BA101 box.
- *10. 2-pipe unit: 1 x valve kit + 1 x installation box for PCB KRP1BA101 + 1 x valve control PCB EKR1C11
4-pipe unit: 2 x valve kit + 1 x installation box for PCB KRP1BA101 + 1 x valve control PCB EKR1C11
- *11. This option is needed to create T1 T2 wire.
- *12. It is possible to change the operation mode, but this will not have an impact on the water temperature.
(No feed back to water source)
It is not possible to select the "auto air flow" setting.
Dry operation can be selected with this remote control, but this function is not available on the FWF model.
- *13. All options are supplied as kit.

3TW33049-1A

1
5

5 Options

5 - 1 Options

FWF-BT-BF

Brief description of purpose of the available options:

Item	Model	FWF02-05B	Description	
1 Decoration Panel (RAL 9010 - grey sealings)	4-way blow	BYFQ60B	Decoration panel for the fan coil unit that is built in the false ceiling. Mandatory when installing the fan coil unit.	
2 Sealing member of air discharge outlet		KDBH44BA60	This option can be used in case the fan coil unit is installed close to a wall on one or more sides (closer than 1500mm). With the blocking parts one more air outlets of the fan coil unit can be closed. --> Fan coil unit can be installed closer to a wall (but further than 200mm)	
3 Panel spacer		KDBQ44B60	Decorative spacer to fill the gap between panel and unit when the height of the suspended ceiling is too small.	
4 Long-life filter		KAFQ441BA60	High quality filter that can be used if supplied filter is damaged.	
5 Fresh air intake kit	Direct installation type	KDDQ44XA60	Kit that can be connected to the ventilation system to supply fresh air to the fan coil unit.	
6 Remote control	Infrared	H/P	BRC7E530	Infrared remote control to control each fan coil unit independently with cooling and heating functionality. It is not possible to select auto air flow with this remote control. Also there is no feedback regarding the operation mode to the "water supply unit".--> Changing the operation mode will not have an effect on the supplied water temperature. Dry operation can be selected, but the FWF unit does not have this function.
		C/O	BRC7E531	Infrared remote control to control each fan coil unit independently with cooling functionality. It is not possible to select auto air flow with this remote control. Also there is no feedback regarding the operation mode to the "water supply unit".--> Changing the operation mode will not have an effect on the supplied water temperature. Dry operation can be selected, but the FWF unit does not have this function.
	Wired	BRC315D7	Wired remote control to control each fan coil unit independently with cooling and heating functionality. There is no weekly timer function in this remote control. Only a limited on/off timer function is available. In case wires need to be installed inside the wall, the KJB212A installation box is required.	
7 Central remote control		DCS302CA51	Remote control for centralised control of all connected fan coil units (only FWF and FWC type).	
7.1 Electrical box with earth terminal (3 blocks)		KJB311A	Requires the KJB311A electrical installation box for the installation.	
8 Unified on/off controller		DCS301BA51	Remote control to switch all connected fan coil units (only FWC and FWF type) ON or OFF. In case unified on/off controller is built in the wall, the electrical box KJB212A kit is required.	
8.1 Electrical box with earth terminal (2 blocks)		KJB212A	For compliance reasons, the noise filter KEK26-1A is required in case a unified on/off controller is installed.	
9 Schedule timer		DST301BA51	Controller with schedule timer functionality for the fan coil units (only FWC and FWF). It is not possible to combine this option with KRP2A52 or KRP4AA53 or EKFCMBCB7 on the same fan coil unit. In case the schedule timer is built in the wall, the electrical box KJB212A is required.	
10 Intelligent touch controller		DCS601C51C	Advanced remote control for centralized control of all connected fan coil units (but only FWF and FWC type and up to 128 fan coil units). More functions are possible than with the central remote control. Compared to VRV systems, it's not possible to use AIRNET and telephone connection. The I-touch can not be used for installations with both DX units and fan coil units. The I-touch can not be used for installations with fan coil units that use Mod Bus communication.	
10.1 Electrical installation box		KJB411A	Electrical installation box KJB411A is needed for the installation of the I-touch remote control.	
11 Remote sensor		KRCS01-1	Sensor to measure the room temperature remotely from a location other than the fan coil unit or remote control.	
12 Remote "On/Off" and "forced off" kit		EKROROA	Option kit to allow a field supplied low voltage contact to control on/off operation of the fan coil unit. Example: to force the fan coil unit off, in case the window in the room is opened.	
13 2-way valve - On/Off		EKMV2C09B7	2-way valve to control the water supply to the fan coil unit. The option kit EKRP1C11 is needed to control the valve.	
14 3-way valve - On/Off		EKMV3C09B7	3-way valve to control the water supply to the fan coil unit. The option kit EKRP1C11 is needed to control the valve.	
15 Valve control PCB		EKR1C11	PCB to control the 2-way and 3-way valves. Only 1 option kit is needed per fan coil unit. It is possible to connect 2 valves on 1 PCB. For the installation of the PCB, the installation box KRP1BA101 is required.	
16 Optional PCB for MOD-bus connection		EKFCMBCB7	PCB to transform the DIII communication of the FWC and FWF fan coil units to Mod Bus RTU RS485 communication. For the installation of the PCB, the installation box KRP1BA101 is required. It's not possible to combine this option with KRP2A52 or KRP4AA53 or DST301BA51 on the same fan coil unit.	
17 Wiring adapter for electrical appendices (1)		KRP2A52	PCB with additional connection for external input/output signals. For the installation of the PCB, the installation box KRP1BA101 is required. It's not possible to combine this option with KRP4AA53 or EKFCMBCB7 or DST301BA51 on the same fan coil unit. Example of input signals: set point, on/off contact. Example of outputs: error stats of fan coil unit, operation status of fan coil unit (on/off). This PCB can control all FWC and FWF fan coil units connected on the same F1/F2 communication wire.	
18 Wiring adapter for electrical appendices (1)		KRP4AA53	PCB with additional connection for external input/output signals. For the installation of the PCB, the installation box KRP1BA101 is required. It's not possible to combine this option with KRP2A52 or EKFCMBCB7 or DST301BA51 on the same fan coil unit. Example of input signals: set point, on/off contact. Example of outputs: error stats of fan coil unit, operation status of fan coil unit (on/off). This PCB can control all FWC and FWF fan coil units connected on the same P1/P2 communication wire.	
19 Installation box for adapter PCB		KRP1BA101	Installation box for some option kits. Maximum 2 boxes can be installed on a single FWF unit.	

3TW33049-2A

6 Capacity tables

6 - 1 Cooling Capacity Tables

1
6

Air temperature (°CDB -°CWB)		22-16															
Water temperature (Entering °C - Leaving °C)		6-11				7-12				8-13				9-14			
Model	Air flow	Total cooling capacity (kW)	Sensible cooling capacity (kW)	Water flow (l/min)	Water pressure drop (kPa)	Total cooling capacity (kW)	Sensible cooling capacity (kW)	Water flow (l/min)	Water pressure drop (kPa)	Total cooling capacity (kW)	Sensible cooling capacity (kW)	Water flow (l/min)	Water pressure drop (kPa)	Total cooling capacity (kW)	Sensible cooling capacity (kW)	Water flow (l/min)	Water pressure drop (kPa)
FWF02BT	HH	1.4	1.1	4.3	3	1.2	1.0	3.8	3	1.0	0.9	3.2	3	0.9	0.8	2.7	3
	H	1.2	0.9	3.7	3	1.0	0.8	3.1	3	0.9	0.8	2.6	2	0.8	0.7	2.2	2
	L	1.1	0.8	3.1	3	0.9	0.7	2.8	3	0.8	0.6	2.2	2	0.7	0.6	2.0	2
FWF03BT	HH	2.3	1.5	6.6	10	1.9	1.3	5.6	8	1.6	1.2	4.8	6	1.4	1.1	4.3	5
	H	2.0	1.2	5.8	8	1.7	1.1	5.1	7	1.4	1.0	4.3	5	1.2	1.0	3.7	4
	L	1.8	1.0	5.3	7	1.5	0.9	4.6	6	1.2	0.8	3.7	4	1.1	0.8	3.4	4
FWF04BT	HH	3.0	2.1	8.7	17	2.5	1.8	7.4	13	2.1	1.6	6.2	9	1.8	1.7	5.3	7
	H	2.4	1.6	7.0	12	2.0	1.4	5.8	8	1.7	1.3	5.0	7	1.5	1.2	4.4	5
	L	1.8	1.0	5.3	7	1.5	0.9	4.6	6	1.2	0.8	3.8	4	1.1	0.8	3.4	4
FWF05BT	HH	3.7	2.6	10.9	25	3.1	2.2	9.1	18	2.5	2.3	7.4	13	2.3	2.1	6.7	11
	H	2.8	2.0	8.2	15	2.4	1.7	7.1	12	2.0	1.6	5.9	9	1.7	1.6	5.1	7
	L	2.1	1.3	6.1	9	1.8	1.2	5.2	7	1.5	1.1	4.5	6	1.2	1.0	3.9	4

Air temperature (°CDB -°CWB)		25-18															
Water temperature (Entering °C - Leaving °C)		6-11				7-12				8-13				9-14			
Model	Air flow	Total cooling capacity (kW)	Sensible cooling capacity (kW)	Water flow (l/min)	Water pressure drop (kPa)	Total cooling capacity (kW)	Sensible cooling capacity (kW)	Water flow (l/min)	Water pressure drop (kPa)	Total cooling capacity (kW)	Sensible cooling capacity (kW)	Water flow (l/min)	Water pressure drop (kPa)	Total cooling capacity (kW)	Sensible cooling capacity (kW)	Water flow (l/min)	Water pressure drop (kPa)
FWF02BT	HH	1.9	1.4	5.5	5	1.6	1.3	4.8	5	1.5	1.2	4.6	4	1.3	1.0	4.1	3
	H	1.6	1.2	4.7	4	1.4	1.1	4.1	3	1.3	1.0	3.9	3	1.1	0.9	3.9	3
	L	1.4	1.0	4.2	4	1.3	0.9	3.7	3	1.2	0.9	4.1	3	1.0	0.8	3.9	3
FWF03BT	HH	3.0	1.8	8.7	17	2.7	1.7	8.0	14	2.4	1.6	7.2	12	2.1	1.4	6.2	9
	H	2.6	1.5	7.7	14	2.4	1.4	7.0	12	2.2	1.4	6.3	10	1.9	1.2	5.4	8
	L	2.3	1.3	6.8	11	2.1	1.2	6.3	10	2.0	1.1	5.7	8	1.6	1.0	5.0	7
FWF04BT	HH	3.9	2.6	11.4	27	3.6	2.4	10.4	23	3.2	2.2	9.4	19	2.7	2.0	8.0	14
	H	3.1	1.9	9.0	18	2.8	1.8	8.2	15	2.6	1.7	7.6	13	2.1	1.5	6.3	10
	L	2.4	1.3	6.9	11	2.1	1.2	6.2	9	2.0	1.1	5.7	8	1.7	1.0	5.0	7
FWF05BT	HH	4.9	3.2	14.2	40	4.5	3.0	13.1	34	4.1	2.8	11.9	29	3.5	2.5	10.1	22
	H	3.8	2.5	11.0	25	3.4	2.3	10.0	21	3.1	2.2	9.0	18	2.7	1.9	7.6	13
	L	2.7	1.6	7.9	14	2.5	1.5	7.3	12	2.2	1.4	6.6	10	1.9	1.3	5.6	8

NOTES

1. The capacity is only guaranteed at the nominal conditions

3TW33042-2

Air temperature (°CDB -°CWB)		27-19															
Water temperature (Entering °C - Leaving °C)		6-11				7-12				8-13				9-14			
Model	Air flow	Total cooling capacity (kW)	Sensible cooling capacity (kW)	Water flow (l/min)	Water pressure drop (kPa)	Total cooling capacity (kW)	Sensible cooling capacity (kW)	Water flow (l/min)	Water pressure drop (kPa)	Total cooling capacity (kW)	Sensible cooling capacity (kW)	Water flow (l/min)	Water pressure drop (kPa)	Total cooling capacity (kW)	Sensible cooling capacity (kW)	Water flow (l/min)	Water pressure drop (kPa)
FWF02BT	HH	2.1	1.5	6.1	6	2.0	1.5	6.0	6	1.7	1.4	5.2	5	1.5	1.3	4.7	4
	H	1.8	1.3	5.4	5	1.7	1.3	4.9	4	1.5	1.2	4.3	4	1.3	1.1	4.1	3
	L	1.6	1.1	4.8	4	1.5	1.1	4.3	4	1.3	1.0	4.0	3	1.2	0.9	3.6	3
FWF03BT	HH	3.4	2.1	10.0	21	3.2	2	9.4	19	2.8	1.8	8.3	15	2.6	1.7	7.5	13
	H	3.0	1.7	8.8	17	2.8	1.7	8.0	14	2.5	1.6	7.3	12	2.3	1.5	6.7	11
	L	2.7	1.4	7.8	14	2.5	1.4	7.2	12	2.2	1.3	6.5	10	2.0	1.2	6.0	9
FWF04BT	HH	4.5	2.9	13.1	34	4.2	2.8	12.4	31	3.7	2.6	10.7	24	3.4	2.4	9.8	20
	H	3.5	2.2	10.3	22	3.3	2.1	9.5	19	2.9	1.9	8.6	16	2.6	1.8	7.8	14
	L	2.7	1.4	7.8	14	2.5	1.4	7.2	12	2.2	1.3	6.5	10	2.0	1.2	6.0	9
FWF05BT	HH	5.6	3.7	16.2	50	5.2	3.5	14.7	42	4.7	3.3	13.4	36	4.3	3.0	12.4	31
	H	4.3	2.8	12.7	32	4.0	2.7	11.5	27	3.6	2.5	10.4	23	3.2	2.3	9.4	19
	L	3.1	1.9	9.0	18	2.9	1.8	8.3	15	2.6	1.7	7.6	13	2.3	1.5	6.8	11

Air temperature (°CDB -°CWB)		30-22															
Water temperature (Entering °C - Leaving °C)		6-11				7-12				8-13				9-14			
Model	Air flow	Total cooling capacity (kW)	Sensible cooling capacity (kW)	Water flow (l/min)	Water pressure drop (kPa)	Total cooling capacity (kW)	Sensible cooling capacity (kW)	Water flow (l/min)	Water pressure drop (kPa)	Total cooling capacity (kW)	Sensible cooling capacity (kW)	Water flow (l/min)	Water pressure drop (kPa)	Total cooling capacity (kW)	Sensible cooling capacity (kW)	Water flow (l/min)	Water pressure drop (kPa)
FWF02BT	HH	3.0	1.8	8.7	11	2.8	1.7	8.2	10	2.6	1.6	7.5	9	2.3	1.5	6.8	7
	H	2.6	1.6	7.8	9	2.4	1.5	7.2	8	2.2	1.4	6.7	7	2.1	1.3	6.0	6
	L	2.3	1.3	6.8	7	2.1	1.2	6.3	7	2.0	1.2	5.8	6	1.8	1.1	5.3	5
FWF03BT	HH	4.8	2.4	13.7	37	4.5	2.3	13.0	34	4.2	2.2	12.2	30	3.9	2.1	11.3	26
	H	4.2	2.0	12.0	29	3.9	2.0	11.5	27	3.7	1.9	10.7	24	3.4	1.8	9.8	20
	L	3.7	1.7	10.6	24	3.5	1.6	10.0	21	3.3	1.5	9.5	19	3.0	1.4	8.8	17
FWF04BT	HH	6.3	3.4	18.0	61	5.9	3.2	17.0	55	5.5	3.1	16.1	50	5.1	2.9	15.0	44
	H	4.9	2.5	14.2	40	4.6	2.4	13.5	36	4.3	2.3	12.7	32	4.0	2.2	11.6	28
	L	3.7	1.7	10.8	24	3.5	1.6	10.0	21	3.3	1.5	9.5	19	3.0	1.4	8.8	17
FWF05BT	HH	7.8	4.5	22.7	94	7.3	4.1	21.3	83	6.9	3.9	20.0	74	6.5	3.7	18.8	66
	H	6.1	3.3	17.6	59	5.7	3.1	16.6	53	5.3	3.0	15.4	46	4.9	2.8	14.4	41
	L	4.3	2.2	12.6	32	4.1	2.1	11.8	28	3.8	2.0	11.0	25	3.5	1.9	10.2	22

NOTES

1. The capacity is only guaranteed at the nominal conditions

3TW33042-2

6 Capacity tables

6 - 2 Heating Capacity Tables

FWF-BT

Air temperature (°CDB)		20		
Water temperature (Entering °C)		50-45		
Model	Airflow	Heating capacity (kW)	Water flow (l/min)	Water pressure drop (kPa)
FWF02BT	HH	2.9	6.0	6
	H	2.6	4.9	4
	L	2.3	4.3	4
FWF03BT	HH	4.0	9.4	19
	H	3.4	8.0	14
	L	2.8	7.2	12
FWF04BT	HH	5.4	12.4	31
	H	4.1	9.5	19
	L	2.8	7.2	12
FWF05BT	HH	6.7	14.7	42
	H	5.3	11.5	27
	L	3.6	8.3	15

Air temperature (°CDB)		22		
Water temperature (Entering °C)		50-45		
Model	Airflow	Heating capacity (kW)	Water flow (l/min)	Water pressure drop (kPa)
FWF02BT	HH	2.7	6.0	6
	H	2.4	4.9	4
	L	2.1	4.3	4
FWF03BT	HH	3.7	9.4	19
	H	3.1	8.0	14
	L	2.6	7.2	12
FWF04BT	HH	5.0	12.4	31
	H	3.8	9.5	19
	L	2.6	7.2	12
FWF05BT	HH	6.2	14.7	42
	H	4.9	11.5	27
	L	3.3	8.3	15

3TW33042-1

NOTE

- The water flow is the same as for cooling mode in the nominal point. Delta T is not fixed.

7 Dimensional drawings

7 - 1 Dimensional Drawings

FWF-BT/BF

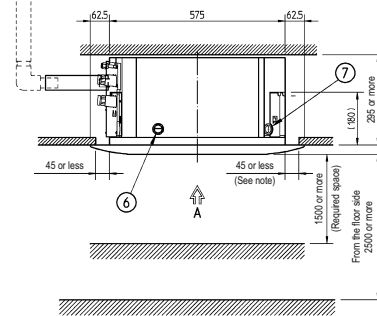
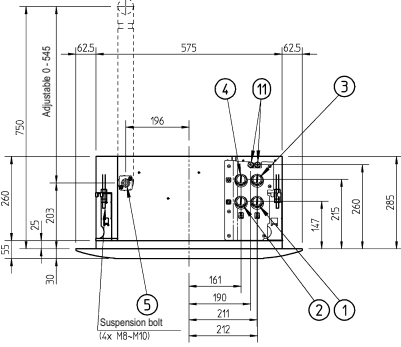
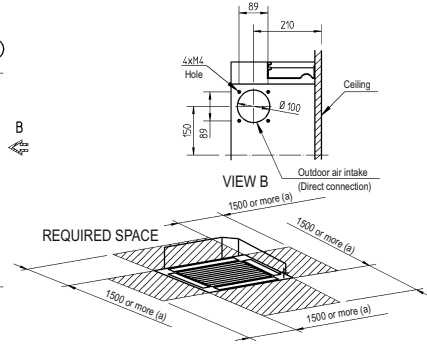
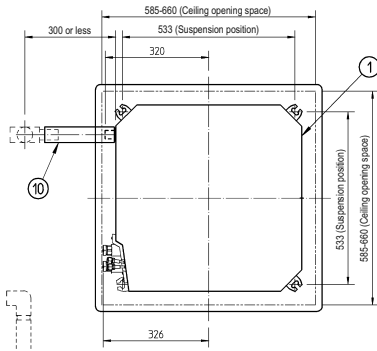
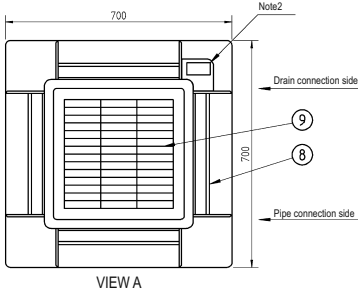

(a) When the discharge grille is covered (by an option kit) the required space is 200mm or more

Nr	Part name	Remark
1	Water pipe connection cooling in	3/4" BSP female (For FWF_B7T: water in)
2	Water pipe connection cooling out	3/4" BSP female (For FWF_B7T: water out)
3	Water pipe connection heating in	3/4" BSP female (For FWF-B7F)
4	Water pipe connection heating out	3/4" BSP female (For FWF-B7F)
5	Drain pipe connection	VP20 (O.D. Ø26)
6	Power supply entry hole	.
7	Transmission wiring entry hole	.
8	Air discharge grille	.
9	Suction grille	.
10	Drain hose (accessory)	1.D.Ø25 (Outlet)
11	Air purge	(1 for FWF_B7T, 2 for FWF_B7F)

DECORATION PANEL

BYFQ60B	White RAL 9010
---------	----------------

3TW33044-1

NOTES

1. Sticking location for manufacturer's label: For indoor unit: on the bell mouth inside suction grille. For decoration panel: on the inner frame inside suction grille.
2. In case of using Infrared remote control, this position will be a signal receiver. Refer to drawing of Infrared remote control for details.
3. When the temperature and humidity in the ceiling exceeds 30°C and RH 80% or the fresh air is inducted into the ceiling or the unit continues 24 hours operation, an additional insulation is required. (Thickness 10mm or more of glaswool or PE foam)
4. Though the installation is acceptable up to maximum of 660 mm square ceiling opening, keep a clearance of 45 mm or less between the main unit and the ceiling opening, so that the panel overlap can be ensured.

7 Dimensional drawings

7 - 2 Dimensional Drawings with Accessories

FWF-BT-BF

VIEW A

①

②

③

A

Dimension between the ceiling and the surface of indoor unit and the surface of ceiling

40 Thickness of panel spacer

255 or more

ITEM	PART NAME	REMARK
1	Indoor unit	-
2	Decoration panel	-
3	Panel spacer	-

NOTE

1. Number of pipe connections and air purges is depending on model type.

3TW33044-2

1
7

8 Centre of gravity

8 - 1 Centre of Gravity

FWF-BT/BF

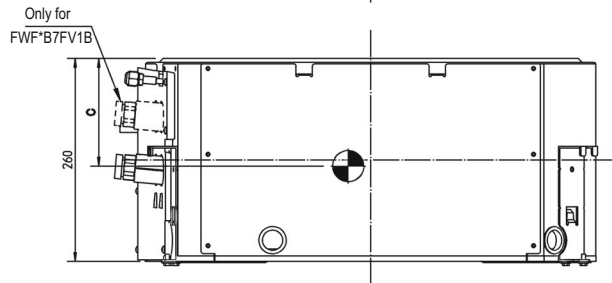
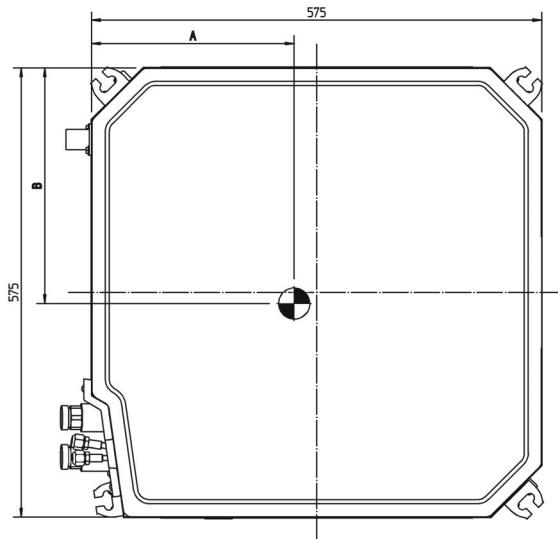

Model	A	B	C
FWF02B7TV1B	259	295	133
FWF02B7FV1B	256	300	132
FWF03-05B7TV1B	267	301	130
FWF03-05B7FV1B	257	312	135

4TW33044-3

9 Piping diagrams

9 - 1 Piping Diagrams

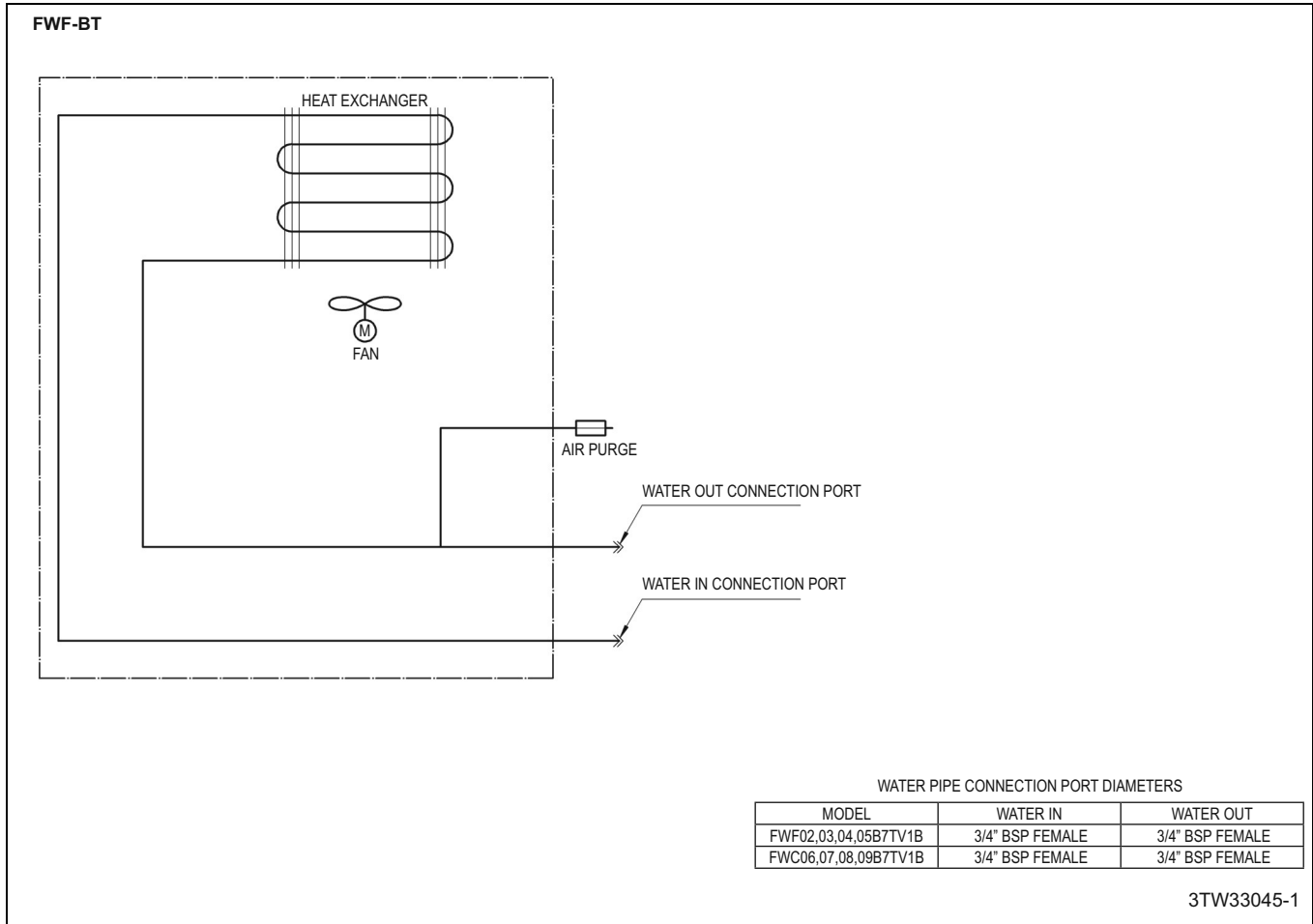

10 Wiring diagrams

10 - 1 Wiring Diagrams - Single Phase

FWF-BT/BF

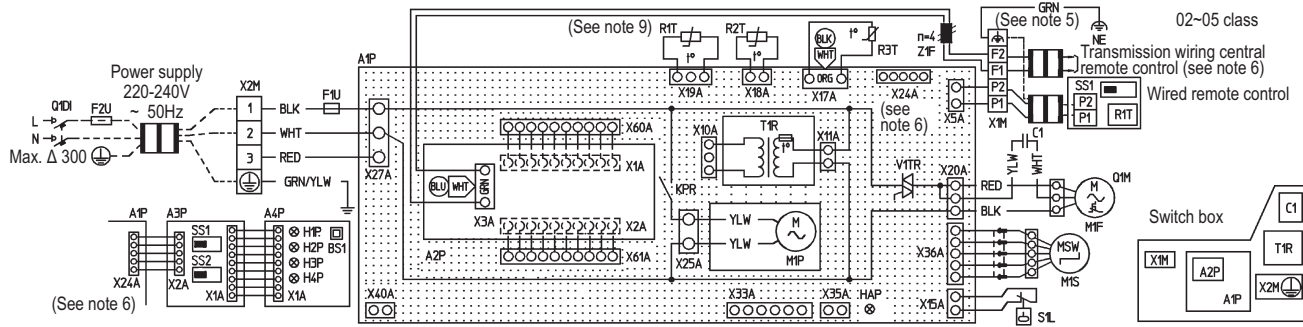

A1P	Printed circuit board	T1R	Transformer (220-240V/22V)	H3P	Light emitting diode (filter sign - red)
A2P	Printed circuit board	V1TR	Phase control circuit	H4P	Light emitting diode (defrost - orange)
C1	Capacitor (M1F)	X1M	Terminal strip	SS1	Selector switch (main/sub)
F1U	Fuse (F5A, 250V)	X2M	Terminal strip	SS2	Selector switch (wireless address set)
F2U	Field fuse	Z1F	Ferrite core	Connector for optional parts	
HAP	Light emitting diode (service monitor green)	TC	Signal transmission circuit	X24A	Connector (infrared remote control)
KPR	Magnetic relay (M1P)	Wired remote control		X33A	Connector (valve control adapter)
M1F	Motor (indoor fan)	R1T	Thermistor (air)	X35A	Connector (external adapter)
M1P	Motor (drain pump)	SS1	Selector switch (main/sub)	X40A	Connector (on/off input from outside)
M1S	Motor (swing flap)	Infrared remote control (receiver/display unit)			
Q1M	Thermo switch (M1F embedded)	A3P	Printed circuit board		
Q1D1	Field earth leak detector (max 300mA)	A4P	Printed circuit board		
R1T	Thermistor (air)	BS1	Push button (on/off)		
R2T	Thermistor	H1P	Light emitting diode (on - red)		
R3T	Thermistor	H2P	Light emitting diode (timer - green)		
S1L	Float switch				

RED: red	YLW: yellow
BLK: black	GRN: green
WHT: white	BLU: blue
ORG: orange	

3TW33046-1

NOTES

- : color of wire, ◻ (marked) color of wire connector, ◻ color of PCB connector
- ◻ : terminal, ◻ : connector, ◻ : wire connector, ◻ : field wiring
- In case using a remote control, connect it to the unit in accordance to the attached installation manual.
- Remote control model varies according to the combination system. See technical data and catalogs, etc. before connecting.
- Ground the shield of the remote control wire to the indoor unit. (In case of using shield wire)
- When using central remote control, see manual for connection to the unit.
- X24A, X33A, X35A and X40A are connected, when optional accessories are being used.
- X24A is connected, when the infrared remote control is being used.
- Availability of R2T and/or R3T is depending on model type.

11 Sound data

11 - 1 Sound Power Spectrum

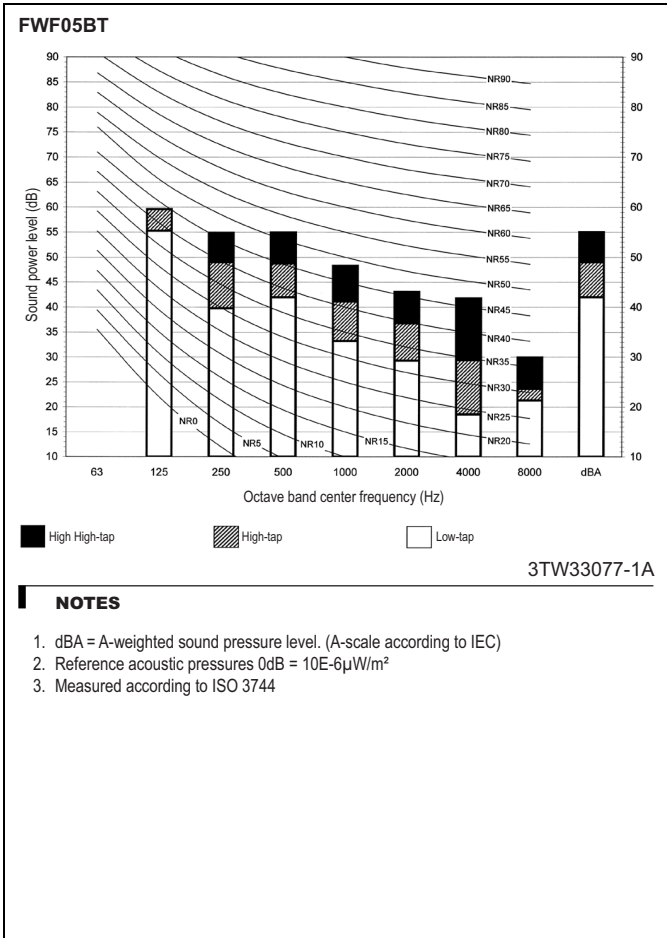
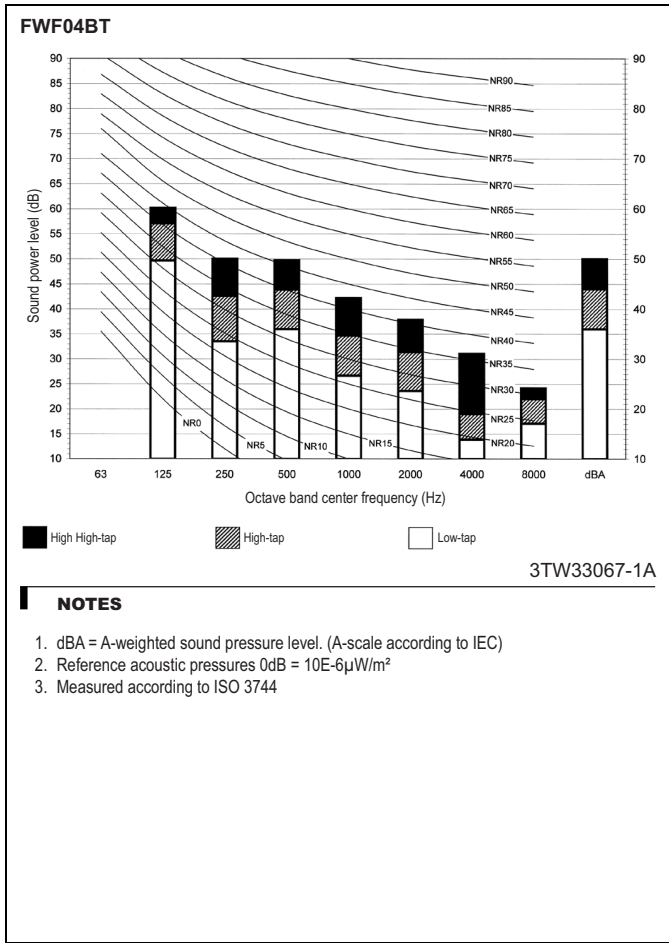
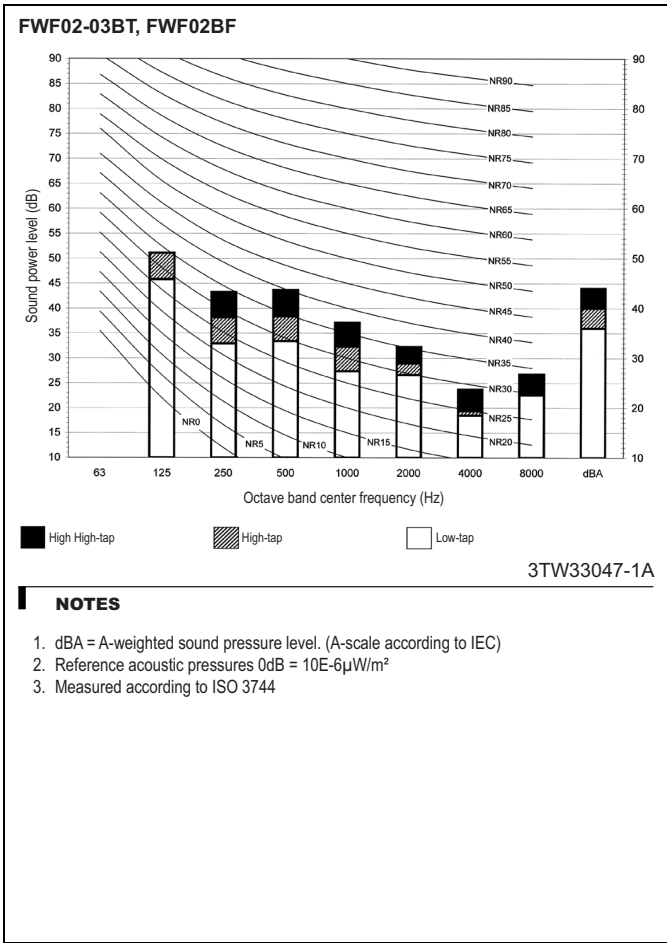

11 Sound data

11 - 2 Sound Pressure Spectrum

1
11

FWF02-03BT, FWF02BF

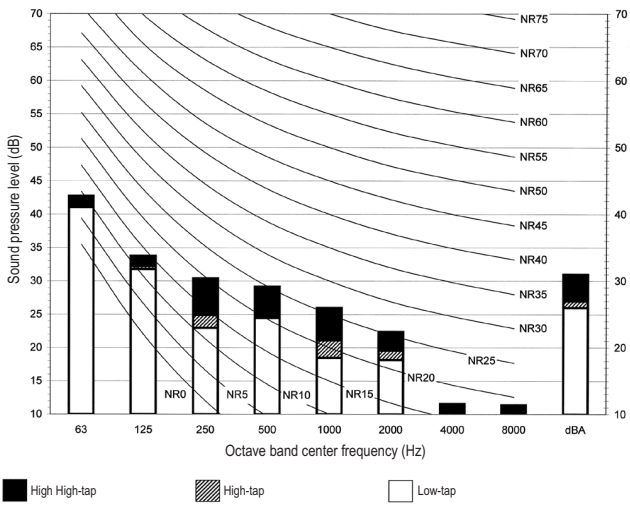

3TW33047-2A

NOTES

1. Data is valid at free field condition
2. Data is valid at nominal operation condition
3. dBA = A-weighted sound pressure level. (A-scale according to IEC)
4. Reference acoustic pressures 0dB = 20μPa
5. Location of microphone.

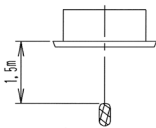

FWF04BT

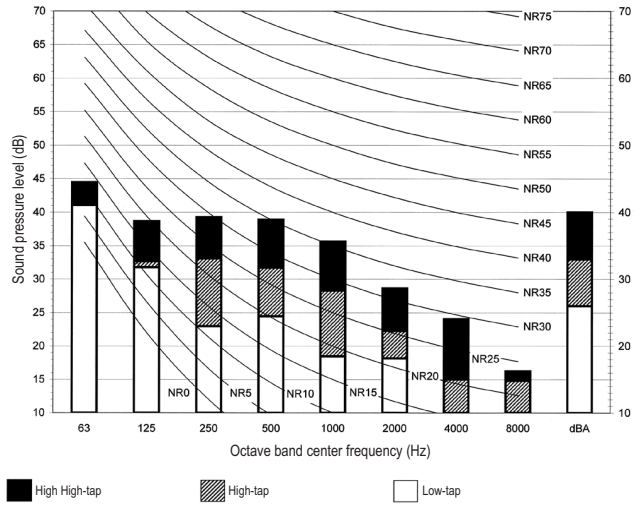

3TW33067-2A

NOTES

1. Data is valid at free field condition
2. Data is valid at nominal operation condition
3. dBA = A-weighted sound pressure level. (A-scale according to IEC)
4. Reference acoustic pressures 0dB = 20μPa
5. Location of microphone.

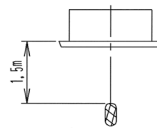

FWF05BT

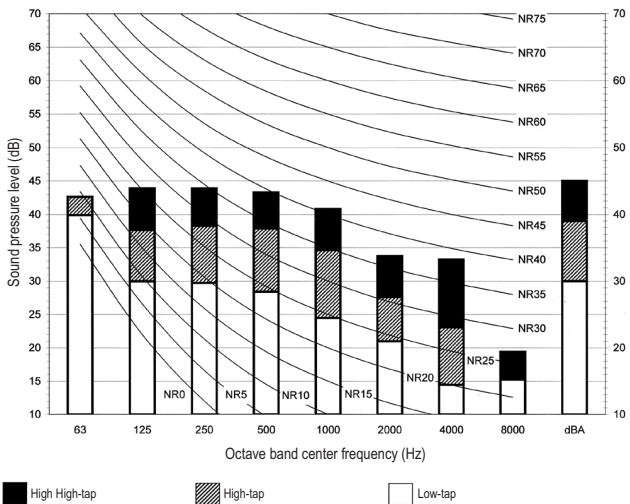

3TW33077-2A

NOTES

1. Data is valid at free field condition
2. Data is valid at nominal operation condition
3. dBA = A-weighted sound pressure level. (A-scale according to IEC)
4. Reference acoustic pressures 0dB = 20μPa
5. Location of microphone.

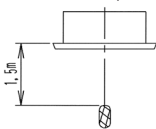

12 Hydraulic performance

12 - 1 Water Pressure Drop Curve Evaporator

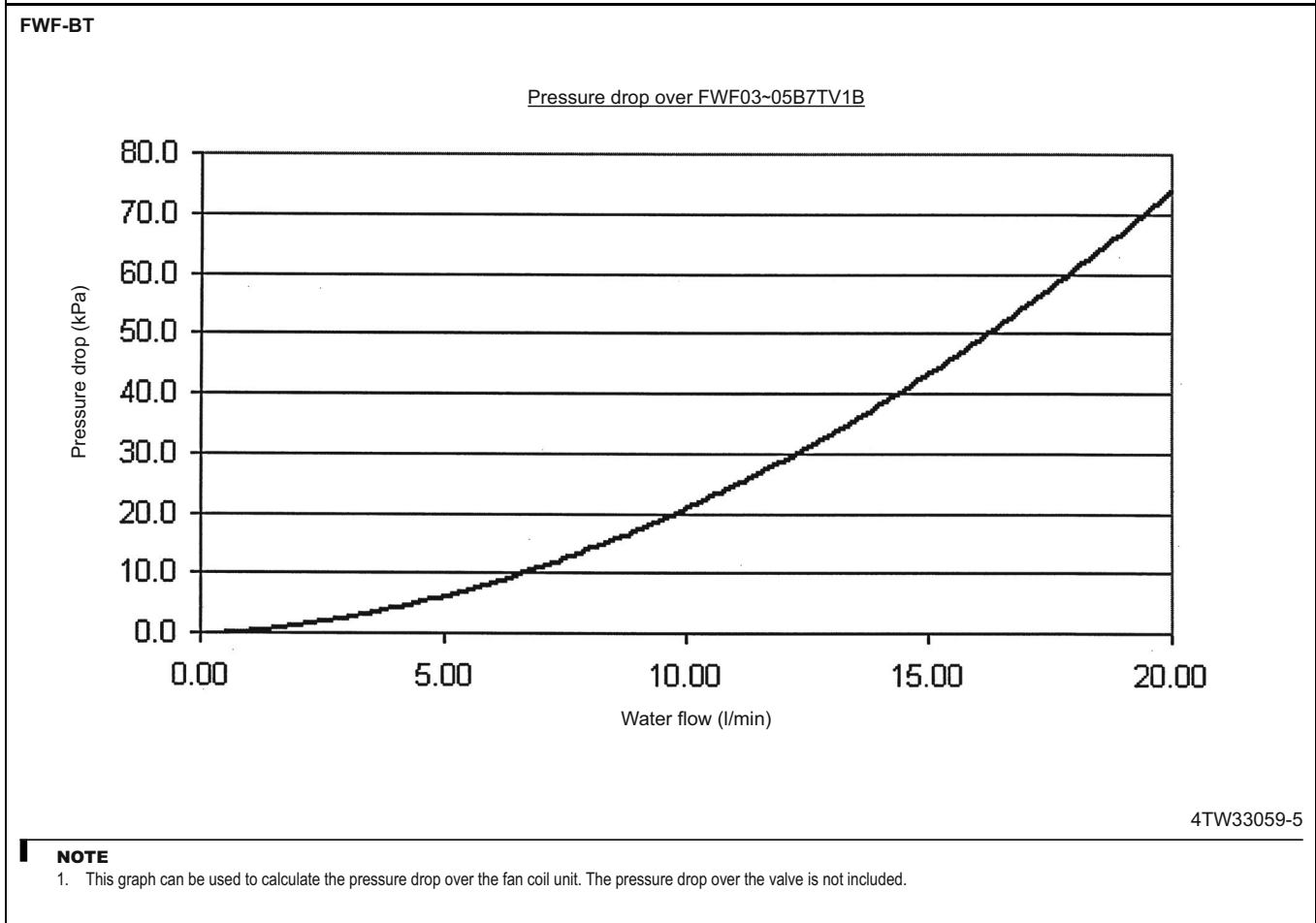
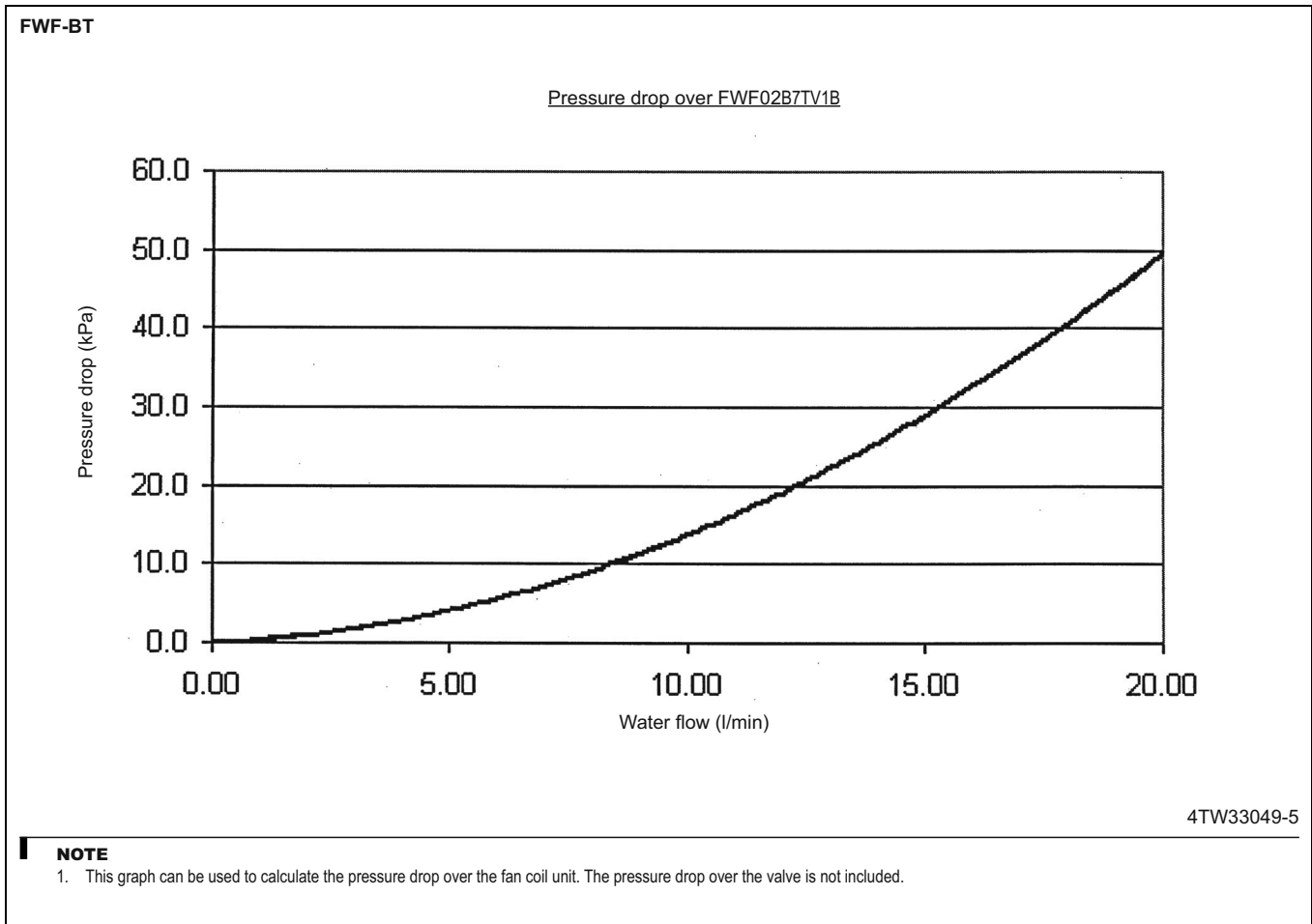

TABLE OF CONTENTS

FWF-BF

1	Features	22
2	Specifications	23
	Technical Specifications	23
	Electrical Specifications	23
3	Electrical data	24
	Electrical Data	24
4	Safety device settings	25
	Safety Device Settings	25
5	Options	26
	Options	26
6	Capacity tables	28
	Cooling Capacity Tables	28
	Heating Capacity Tables	29
7	Dimensional drawings	30
	Dimensional Drawings	30
	Dimensional Drawings with Accessories	31
8	Centre of gravity	32
	Centre of Gravity	32
9	Piping diagrams	33
	Piping Diagrams	33
10	Wiring diagrams	34
	Wiring Diagrams - Single Phase	34
11	Sound data	35
	Sound Power Spectrum	35
	Sound Pressure Spectrum	36
12	Hydraulic performance	37
	Water Pressure Drop Curve Evaporator	37

1 Features

- Modern style decoration panel in white (RAL9010)
- Compact casing (570mm in width and depth) enables unit to fit flush into ceilings and match standard architectural modules, without cutting ceiling tiles
- Comfortable horizontal auto swing ensures draughtfree operation and prevents ceiling soiling
- Fresh air intake for healthy living
- Possibility to shut 1 or 2 flaps for easy installation in corners
- Standard drain pump with 750mm lift

2

1



2 Specifications

2-1 Technical Specifications				FWF02BF	FWF03BF	FWF04BF	FWF05BF
Cooling capacity	Total capacity	Super high	kW	2.0 (1)	2.7 (1)	3.5 (1)	4.5 (1)
		High	kW	1.7 (1)	2.3 (1)	2.8 (1)	3.5 (1)
		Low	kW	1.4 (1)	1.8 (1)		2.6 (1)
	Sensible capacity	Super high	kW	1.5 (1)	1.7 (1)	2.4 (1)	3.3 (1)
		High	kW	1.3 (1)		1.7 (1)	2.3 (1)
		Low	kW	1.1 (1)	1.0 (1)		1.5 (1)
Heating capacity	4-Pipe	Super high	kW	3.9 (3)	3.8 (3)	4.9 (3)	6.1 (3)
		High	kW	3.1 (3)	3.3 (3)	3.9 (3)	4.8 (3)
		Low	kW	2.3 (3)	2.8 (3)		3.5 (3)
Power input	Super high	W	74		94	121	
	High	W	67	62	74	93	
	Low	W	60	55		66	
Casing	Material			Galvanised steel plate			
Dimensions	Unit	Height	mm	285			
		Width	mm	575			
		Depth	mm	575			
Weight	Unit	kg	19	20			
Heat exchanger	Rows	Quantity	2	3			
	Fin pitch		mm	1.5			
Water pressure drop	Cooling	kPa	6	13	21	33	
	Heating	kPa	12	6	9	13	
Fan	Type		Turbo fan				
	Quantity		1				
	Air flow rate	High	m ³ /h	468	438	618	822
		Medium	m ³ /h	390	366	456	612
Low		m ³ /h	318	300		390	
Fan motor	Speed	Steps	3				
	Model		QTS32C15M				
Sound power level	Super high	dBA	44	46	52	57	
	High	dBA	40	42	46	51	
	Low	dBA	36	38		44	
Sound pressure level	Super high	dBA	31	33	42	47	
	High	dBA	27	29	35	41	
	Low	dBA	26	27		32	
Insulation material			Foamed polystyrene / foamed polyethylene				

Standard Accessories : Screws;

Standard Accessories : Drain hose;

Standard Accessories : O ring;

Standard Accessories : Insulation;

Standard Accessories : Installation guide;

Standard Accessories : Washer for hanger bracket;

Standard Accessories : Clamp for drain hose;

Standard Accessories : Installation and operation manual;

2-2 Electrical Specifications			FWF02BF	FWF03BF	FWF04BF	FWF05BF
Power supply	Phase		1~			
	Frequency	Hz	50			
	Voltage	V	220-440			

Notes

(1) Cooling: air 27°CDB, 19°CWB; entering water 7°C; leaving water 12°C

(2) Heating: 4 pipe: air 20°CDB; entering water 70°C; leaving water 60°C

(3) Do not let water of less than 5°C or more than 50°/70°C enter the unit, this may damage the unit

(4) Height includes switch box

3 Electrical data

3 - 1 Electrical Data

FWF-BT-BF

UNITS					POWER SUPPLY		IFM		INPUT (W)	
MODEL	TYPE	Hz	VOLTAGE RANGE	VOLTAGE LIMITS	MCA	MFA	kW	FLA	COOLING	HEATING
FWF02BT	V1	50	220-240	MAX. 264 MIN. 198	0.6	16	0.055	0.5	74	74
FWF03BT					0.6	16	0.055	0.5	74	74
FWF04BT					0.7	16	0.055	0.6	90	90
FWF05BT					0.8	16	0.055	0.7	118	118
FWF02BF	V1	50	220-240	MAX. 242 MIN. 198	0.6	16	0.055	0.5	74	74
FWF03BF					0.6	16	0.055	0.5	74	74
FWF04BF					0.7	16	0.055	0.6	94	94
FWF05BF					0.8	16	0.055	0.7	121	121

Symbols:

- MCA : Min Circuit Amps (A)
- MFA : Max. Fuse Amps (See note 5)
- kW : FAN Motor Rated Output (kW)
- FLA : Full Load Amps (A)
- IFM : Indoor Fan Motor

NOTES

1. Voltage limits:
Units are suitable for use on electrical systems where voltage supplied to unit terminals is not below or above listed range limits.
2. Maximum allowable voltage unbalanced between phases is 2%.
3. MCA/MFA
MCA = 1.25 x FLA
MFA <= 4 x FLA
(Next lower standard fuse rating min. 16A)
4. Select wire size based on the MCA.
5. Instead of fuse, use Circuit Breaker.

4TW33041-2

2
3

4 Safety device settings

4 - 1 Safety Device Settings

FWF-BT-BF

		02	03	04	05
FWF-BF/BT	PC board fuse		250V 5A		
	Fan motor thermal fuse	°C	---		
	Fan motor thermal protector	°C	OFF: 130±5 ON: 83±20		

4TW33049-4

2

4

5 Options

5 - 1 Options

FWF-BT/BF

Options

Item	Model	FWF02-05B
1	Decoration Panel (RAL 9010 - grey sealings)	4-way blow BYFQ60B
2	Sealing member of air discharge outlet	KDBH44BA60
3	Panel spacer	KDBQ44B60
4	Long-life filter	KAFQ441BA60
5	Fresh air intake kit	Direct installation type KDDQ44XA60

Control system

Item	Model	FWF02-05B	
1	Remote control	Infrared	
		H/P	BRC7E530 (*12)
		C/O	BRC7E531 (*12)
	Wired	BRC315D7 (*1)	
2	Central remote control	DCS302CA51 (*2)	
2.1	Electrical box with earth terminal (3 blocks)	KJB311A	
3	Unified on/off controller	DCS301BA51 (*5)	
3.1	Electrical box with earth terminal (2 blocks)	KJB212A	
4	Schedule timer	DST301BA51 (*5)(*8)	
5	Wiring adapter for electrical appendices (1)	KRP2A52 (*4)(*8)	
6	Wiring adapter for electrical appendices (2)	KRP4AA53 (*4)(*8)	
7	Installation box for adapter PCB	KRP1BA101 (*9)	
8	Remote sensor	KRCS01-1	
10	Intelligent touch controller	DCS601C51C (*3)(*7)	
10.1	Electrical installation box	KJB411A	
11	Optional PCB for MOD-bus connection	EKFCMBCB7 (*4)(*8)	
12	2-way valve - On/Off	EKMV2C09B7 (*4)(*6)(*10)	
13	3-way valve - On/Off	EKMV3C09B7 (*4)(*6)(*10)	
14	Valve control PCB	EKR1PC11	
15	Remote "On/Off" and "forced off" kit	EKROROA (*11)	

NOTES

- *1. Optional, electrical installation box with earth terminal KJB212A is required, if controller wires need to be installed in the wall.
- *2. Requires electrical installation box with earth terminal KJB311A.
- *3. Requires electrical installation box KJB411A.
- *4. Requires installation box KRP1BA101.
- *5. Requires electrical installation box with earth terminal KJB212A if built in the wall.
- *6. Requires valve control PCB EKR1PC11.
- *7. I-touch:
 - Not allowed to use the i-touch for an installation with both fan coils and VRV® units.
 - Can not be used in combination with fan coil units, that use MOD bus communication.
 - No Airmet or telephone connection possible.
- *8. Only 1 of these 4 options can be installed on 1 indoor unit.
- *9. Max. 2 KRP1BA101 boxes can be mounted on the unit. Max. 1 PCB can be mounted in 1 KRP1BA101 box.
- *10. 2-pipe unit: 1 x valve kit + 1 x installation box for PCB KRP1BA101 + 1 x valve control PCB EKR1PC11
4-pipe unit: 2 x valve kit + 1 x installation box for PCB KRP1BA101 + 1 x valve control PCB EKR1PC11
- *11. This option is needed to create T1 T2 wire.
- *12. It is possible to change the operation mode, but this will not have an impact on the water temperature.
(No feed back to water source)
It is not possible to select the "auto air flow" setting.
Dry operation can be selected with this remote control, but this function is not available on the FWF model.
- *13. All options are supplied as kit.

3TW33049-1A

5 Options

5 - 1 Options

FWF-BT-BF

Brief description of purpose of the available options:

Item	Model	FWF02-05B	Description	
1 Decoration Panel (RAL 9010 - grey sealings)	4-way blow	BYFQ60B	Decoration panel for the fan coil unit that is built in the false sealing. Mandatory when installing the fan coil unit	
2 Sealing member of air discharge outlet		KDBH44BA60	This option can be used in case the fan coil unit is installed close to a wall on one or more sides (closer than 1500mm). With the blocking parts one more air outlets of the fan coil unit can be closed. --> Fan coil unit can be installed closer to a wall (but further than 200mm)	
3 Panel spacer		KDBQ44B60	Decorative spacer to fill the gap between panel and unit when the height of the suspended ceiling is too small.	
4 Long-life filter		KAFQ441BA60	High quality filter that can be used if supplied filter is damaged.	
5 Fresh air intake kit	Direct installation type	KDDQ44XA60	Kit that can be connected to the ventilation system to supply fresh air to the fan coil unit.	
6 Remote control	Infrared	H/P	BRC7E530	Infrared remote control to control each fan coil unit independently with cooling and heating functionality. It is not possible to select auto air flow with this remote control. Also there is no feedback regarding the operation mode to the "water supply unit".--> Changing the operation mode will not have an effect on the supplied water temperature. Dry operation can be selected, but the FWF unit does not have this function.
		C/O	BRC7E531	Infrared remote control to control each fan coil unit independently with cooling functionality. It is not possible to select auto air flow with this remote control. Also there is no feedback regarding the operation mode to the "water supply unit".--> Changing the operation mode will not have an effect on the supplied water temperature. Dry operation can be selected, but the FWF unit does not have this function.
	Wired	BRC315D7	Wired remote control to control each fan coil unit independently with cooling and heating functionality. There is no weekly timer function in this remote control. Only a limited on/off timer function is available. In case wires need to be installed inside the wall, the KJB212A installation box is required.	
7 Central remote control		DCS302CA51	Remote control for centralised control of all connected fan coil units (only FWF and FWC type).	
7.1 Electrical box with earth terminal (3 blocks)		KJB311A	Requires the KJB311A electrical installation box for the installation.	
8 Unified on/off controller		DCS301BA51	Remote control to switch all connected fan coil units (only FWC and FWF type) ON or OFF. In case unified on/off controller is built in the wall, the electrical box KJB212A kit is required.	
8.1 Electrical box with earth terminal (2 blocks)		KJB212A	For compliance reasons, the noise filter KEK26-1A is required in case a unified on/off controller is installed.	
9 Schedule timer		DST301BA51	Controller with schedule timer functionality for the fan coil units (only FWC and FWF). It is not possible to combine this option with KRP2A52 or KRP4AA53 or EKFCMBCB7 on the same fan coil unit. In case the schedule timer is built in the wall, the electrical box KJB212A is required.	
10 Intelligent touch controller		DCS601C51C	Advanced remote control for centralized control of all connected fan coil units (but only FWF and FWC type and up to 128 fan coil units). More functions are possible than with the central remote control. Compared to VRV systems, it's not possible to use AIRNET and telephone connection. The I-touch can not be used for installations with both DX units and fan coil units. The I-touch can not be used for installations with fan coil units that use Mod Bus communication.	
10.1 Electrical installation box		KJB411A	Electrical installation box KJB411A is needed for the installation of the I-touch remote control.	
11 Remote sensor		KRCS01-1	Sensor to measure the room temperature remotely from a location other than the fan coil unit or remote control.	
12 Remote "On/Off" and "forced off" kit		EKROROA	Option kit to allow a field supplied low voltage contact to control on/off operation of the fan coil unit. Example: to force the fan coil unit off, in case the window in the room is opened.	
13 2-way valve - On/Off		EKMV2C09B7	2-way valve to control the water supply to the fan coil unit. The option kit EKRP1C11 is needed to control the valve.	
14 3-way valve - On/Off		EKMV3C09B7	3-way valve to control the water supply to the fan coil unit. The option kit EKRP1C11 is needed to control the valve.	
15 Valve control PCB		EKRP1C11	PCB to control the 2-way and 3-way valves. Only 1 option kit is needed per fan coil unit. It is possible to connect 2 valves on 1 PCB. For the installation of the PCB, the installation box KRP1BA101 is required.	
16 Optional PCB for MOD-bus connection		EKFCMBCB7	PCB to transform the DIII communication of the FWC and FWF fan coil units to Mod Bus RTU RS485 communication. For the installation of the PCB, the installation box KRP1BA101 is required. It's not possible to combine this option with KRP2A52 or KRP4AA53 or DST301BA51 on the same fan coil unit.	
17 Wiring adapter for electrical appendices (1)		KRP2A52	PCB with additional connection for external input/output signals. For the installation of the PCB, the installation box KRP1BA101 is required. It's not possible to combine this option with KRP4AA53 or EKFCMBCB7 or DST301BA51 on the same fan coil unit. Example of input signals: set point, on/off contact. Example of outputs: error stats of fan coil unit, operation status of fan coil unit (on/off). This PCB can control all FWC and FWF fan coil units connected on the same F1/F2 communication wire.	
18 Wiring adapter for electrical appendices (1)		KRP4AA53	PCB with additional connection for external input/output signals. For the installation of the PCB, the installation box KRP1BA101 is required. It's not possible to combine this option with KRP2A52 or EKFCMBCB7 or DST301BA51 on the same fan coil unit. Example of input signals: set point, on/off contact. Example of outputs: error stats of fan coil unit, operation status of fan coil unit (on/off). This PCB can control all FWC and FWF fan coil units connected on the same P1/P2 communication wire.	
19 Installation box for adapter PCB		KRP1BA101	Installation box for some option kits. Maximum 2 boxes can be installed on a single FWF unit.	

3TW33049-2A

6 Capacity tables

6 - 1 Cooling Capacity Tables

2
6

FWF-BF		22-16															
Air temperature (°CDB -°CWB)		6-11				7-12				8-13				9-14			
Water temperature (Entering °C - Leaving °C)		Total cooling capacity (kW)	Sensible cooling capacity (kW)	Water flow (l/min)	Water pressure drop (kPa)	Total cooling capacity (kW)	Sensible cooling capacity (kW)	Water flow (l/min)	Water pressure drop (kPa)	Total cooling capacity (kW)	Sensible cooling capacity (kW)	Water flow (l/min)	Water pressure drop (kPa)	Total cooling capacity (kW)	Sensible cooling capacity (kW)	Water flow (l/min)	Water pressure drop (kPa)
Model	Air flow																
FWF02BF	HH	1.4	1.1	4.1	3	1.1	1.0	3.5	2	1.0	0.9	3.1	2	0.8	0.8	2.6	2
	H	1.2	0.9	3.7	2	1.0	0.8	3.0	2	0.9	0.8	2.6	2	0.7	0.7	2.2	2
	L	1.0	0.8	3.0	2	0.8	0.7	2.5	2	0.7	0.7	2.3	2	0.6	0.6	1.8	2
FWF03BF	HH	1.9	1.2	5.7	10	1.6	1.1	5.6	8	1.4	1.0	4.1	6	1.1	1.0	4.3	5
	H	1.6	0.9	4.8	8	1.4	0.8	5.1	7	1.2	0.8	3.4	5	1.0	0.7	3.1	4
	L	1.2	0.7	3.8	7	1.0	0.6	4.6	6	1.1	0.6	2.8	4	0.7	0.6	2.5	4
FWF04BF	HH	2.4	1.7	7.1	17	2.0	1.5	7.4	13	1.8	1.4	5.3	9	1.5	1.4	5.3	7
	H	1.9	1.2	5.7	12	1.7	1.1	5.8	8	1.4	1.0	4.2	7	1.2	1.0	4.4	5
	L	1.3	0.7	3.8	7	1.1	0.6	4.6	6	1.1	0.6	2.8	4	0.7	0.6	2.5	4
FWF05BF	HH	3.2	2.4	9.4	19	2.5	2.0	7.4	13	2.2	1.9	6.4	10	1.9	1.8	5.8	8
	H	2.4	1.6	7.2	12	2.0	1.5	6.0	9	1.8	1.4	5.2	7	1.5	1.4	4.5	6
	L	1.8	1.1	5.4	8	1.5	1.0	4.6	6	1.3	0.9	4.1	6	1.1	0.9	3.5	4

FWF-BF		25-18															
Air temperature (°CDB -°CWB)		6-11				7-12				8-13				9-14			
Water temperature (Entering °C - Leaving °C)		Total cooling capacity (kW)	Sensible cooling capacity (kW)	Water flow (l/min)	Water pressure drop (kPa)	Total cooling capacity (kW)	Sensible cooling capacity (kW)	Water flow (l/min)	Water pressure drop (kPa)	Total cooling capacity (kW)	Sensible cooling capacity (kW)	Water flow (l/min)	Water pressure drop (kPa)	Total cooling capacity (kW)	Sensible cooling capacity (kW)	Water flow (l/min)	Water pressure drop (kPa)
Model	Air flow																
FWF02BF	HH	1.8	1.3	5.7	6	1.5	1.2	4.8	4	1.3	1.1	4.2	4	1.3	1.0	4.1	3
	H	1.6	1.2	4.7	4	1.4	1.1	4.1	3	1.3	1.0	3.9	3	1.1	0.9	3.9	3
	L	1.3	1.0	4.1	3	1.2	1.0	4.0	3	1.1	0.9	4.1	3	0.9	0.8	3.9	3
FWF03BF	HH	2.5	1.5	7.4	13	2.3	1.5	6.9	11	2.1	1.3	6.1	9	1.7	1.2	5.1	7
	H	2.2	1.2	6.4	10	2.0	1.1	5.8	8	1.8	1.0	5.2	7	1.5	0.9	4.3	5
	L	1.7	0.9	5.0	7	1.5	0.8	4.6	6	1.3	0.8	4.1	5	1.2	0.7	4.1	5
FWF04BF	HH	3.3	2.2	9.6	20	3.0	2.1	8.8	17	2.6	1.9	7.8	14	2.2	1.7	6.4	10
	H	2.6	1.5	7.6	13	2.4	1.4	7.0	12	2.1	1.3	6.2	9	1.8	1.2	5.2	7
	L	1.7	0.9	5.0	7	1.5	0.8	4.6	6	1.3	0.8	4.1	5	1.2	0.7	4.1	5
FWF05BF	HH	4.3	3.1	12.6	32	3.8	2.9	11.2	26	3.5	2.6	10.1	22	2.8	2.2	8.1	15
	H	3.3	2.1	9.6	20	3.0	2.0	8.8	17	2.7	1.8	7.8	14	2.2	1.6	6.3	10
	L	2.5	1.4	7.2	12	2.2	1.3	6.6	10	2.0	1.2	5.8	8	1.7	1.1	5.0	7

NOTES

1. The capacity is only guaranteed at the nominal conditions

3TW33082-2

FWF-BF		27-19															
Air temperature (°CDB -°CWB)		6-11				7-12				8-13				9-14			
Water temperature (Entering °C - Leaving °C)		Total cooling capacity (kW)	Sensible cooling capacity (kW)	Water flow (l/min)	Water pressure drop (kPa)	Total cooling capacity (kW)	Sensible cooling capacity (kW)	Water flow (l/min)	Water pressure drop (kPa)	Total cooling capacity (kW)	Sensible cooling capacity (kW)	Water flow (l/min)	Water pressure drop (kPa)	Total cooling capacity (kW)	Sensible cooling capacity (kW)	Water flow (l/min)	Water pressure drop (kPa)
Model	Air flow																
FWF02BF	HH	2.2	1.5	6.4	7	2.0	1.5	5.7	6	1.7	1.4	5.3	5	1.6	1.2	4.7	4
	H	1.9	1.3	5.4	5	1.7	1.3	4.9	4	1.5	1.2	4.4	4	1.4	1.1	4.1	3
	L	1.5	1.1	4.4	4	1.4	1.1	4.1	3	1.2	1.0	3.7	3	1.2	0.9	3.4	3
FWF03BF	HH	2.9	1.8	8.5	16	2.7	1.7	7.7	13	2.4	1.6	7.2	12	2.2	1.4	6.4	10
	H	2.5	1.3	7.2	12	2.3	1.3	6.6	10	2.1	1.2	6.1	9	1.8	1.1	5.3	7
	L	2.0	1.0	5.7	8	1.8	1.0	5.2	7	1.6	0.9	4.8	6	1.4	0.8	4.1	5
FWF04BF	HH	3.8	2.5	11.1	25	3.5	2.4	10.0	21	3.2	2.2	9.3	19	2.8	2.0	8.1	15
	H	3.0	1.7	8.7	17	2.8	1.7	8.1	15	2.5	1.6	7.3	12	2.2	1.4	6.5	10
	L	2.0	1.0	5.7	8	1.8	1.0	5.2	7	1.6	0.9	4.8	6	1.4	0.8	4.1	5
FWF05BF	HH	4.9	3.4	14.2	40	4.5	3.3	12.8	33	4.0	3.1	11.8	28	3.6	2.8	10.5	23
	H	3.8	2.4	10.9	25	3.5	2.3	10	21	3.1	2.1	9.2	18	2.8	1.9	8.1	15
	L	2.8	1.5	8.2	15	2.6	1.5	7.5	13	2.3	1.4	6.8	11	2.1	1.3	6.2	9

FWF-BF		30-22															
Air temperature (°CDB -°CWB)		6-11				7-12				8-13				9-14			
Water temperature (Entering °C - Leaving °C)		Total cooling capacity (kW)	Sensible cooling capacity (kW)	Water flow (l/min)	Water pressure drop (kPa)	Total cooling capacity (kW)	Sensible cooling capacity (kW)	Water flow (l/min)	Water pressure drop (kPa)	Total cooling capacity (kW)	Sensible cooling capacity (kW)	Water flow (l/min)	Water pressure drop (kPa)	Total cooling capacity (kW)	Sensible cooling capacity (kW)	Water flow (l/min)	Water pressure drop (kPa)
Model	Air flow																
FWF02BF	HH	3.0	1.8	9.0	12	2.8	1.7	8.5	11	2.6	1.6	7.8	9	2.3	1.5	7.1	8
	H	2.6	1.6	7.8	9	2.5	1.5	7.2	8	2.3	1.4	6.7	7	2.1	1.3	6.0	6
	L	2.1	1.3	6.3	7	2.0	1.3	5.8	6	1.8	1.2	5.4	5	1.7	1.1	5.0	5
FWF03BF	HH	4.1	2.1	12.0	29	3.8	2.0	11.2	26	3.6	1.9	10.5	23	3.3	1.8	9.7	20
	H	3.5	1.6	10.1	22	3.2	1.5	9.4	19	3.0	1.4	8.8	17	2.8	1.3	8.2	15
	L	2.7	1.2	7.8	14	2.5	1.1	7.4	13	2.4	1.1	6.9	11	2.2	1.0	6.4	10
FWF04BF	HH	5.4	2.9	15.5	46	5.0	2.8	14.6	42	4.7	2.7	13.6	37	4.3	2.5	12.6	32
	H	4.2	2.0	12.2	30	4.0	2.0	11.5	27	3.7	1.9	10.7	24	3.4	1.8	10.0	21
	L	2.7	1.2	7.8	14	2.5	1.1	7.4	13	2.4	1.1	6.9	11	2.2	1.0	6.4	10
FWF05BF	HH	6.9	4.0	20.0	74	6.5	3.9	19.0	68	6.1	3.7	17.6	59	5.6	3.5	16.3	51
	H	5.4	2.8	15.6	47	5.0	2.7	14.6	42	4.7	2.5	13.6	37	4.3	2.4	12.6	32
	L	3.9	1.8	11.2	26	3.6	1.7	10.5	23	3.4	1.6	9.9	21	3.2	1.5	9.3	19

NOTES

1. The capacity is only guaranteed at the nominal conditions

3TW33082-2

6 Capacity tables

6 - 2 Heating Capacity Tables

FWF-BF										
Air temperature (°CDB -°CWB)		20								
Water temperature (Entering °C - Leaving °C)		50-45			60-50			70-60		
Model	Airflow	Heating capacity (kW)	Water flow (l/min)	Water pressure drop (kPa)	Heating capacity (kW)	Water flow (l/min)	Water pressure drop (kPa)	Heating capacity (kW)	Water flow (l/min)	Water pressure drop (kPa)
FWF02BF	HH	2.3	6.8	15	2.9	4.2	7	3.9	6.0	12
	H	1.9	5.5	11	2.3	3.4	5	3.1	4.5	8
	L	1.4	4.1	7	1.7	2.6	4	2.3	3.3	5
FWF03BF	HH	2.3	6.8	9	2.8	4.2	4	3.8	5.4	6
	H	2.0	5.9	7	2.5	3.6	3	3.3	4.7	5
	L	1.7	5.0	5	2.1	3.2	3	2.8	4.0	4
FWF04BF	HH	2.9	8.5	13	3.6	5.2	5	4.9	7.7	11
	H	2.4	7.0	9	2.9	4.3	4	3.9	5.6	6
	L	1.7	5.0	5	2.1	3.2	3	2.8	4.0	4
FWF05BF	HH	3.7	10.8	20	4.5	6.6	8	6.1	8.7	13
	H	2.9	8.5	13	3.6	5.2	5	4.8	6.9	9
	L	2.1	6.2	7	2.6	3.8	3	3.5	5.0	5

FWF-BF										
Air temperature (°CDB -°CWB)		22								
Water temperature (Entering °C - Leaving °C)		50-45			60-50			70-60		
Model	Airflow	Heating capacity (kW)	Water flow (l/min)	Water pressure drop (kPa)	Heating capacity (kW)	Water flow (l/min)	Water pressure drop (kPa)	Heating capacity (kW)	Water flow (l/min)	Water pressure drop (kPa)
FWF02BF	HH	2.2	6.4	14	2.7	3.9	6	3.6	5.2	10
	H	1.7	5.1	10	2.1	3.1	5	2.9	4.2	7
	L	1.3	3.8	6	1.6	2.4	3	2.1	3.1	5
FWF03BF	HH	2.1	6.3	8	2.7	3.9	3	3.6	5.2	5
	H	1.9	5.5	6	2.3	3.4	3	3.1	4.5	4
	L	1.6	4.6	4	2.2	3.2	3	2.6	3.8	3
FWF04BF	HH	2.7	8.0	11	3.3	4.9	5	4.5	6.5	8
	H	2.2	6.4	8	2.7	3.9	3	3.7	5.3	6
	L	1.6	4.6	4	2.6	3.2	3	2.6	3.8	3
FWF05BF	HH	3.5	10.2	18	4.2	6.0	7	5.7	8.3	12
	H	2.7	8.0	11	3.3	4.8	5	4.5	6.6	8
	L	2.0	5.8	7	2.4	3.6	3	3.3	4.7	5

3TW33082-1

2
6

7 Dimensional drawings

7 - 1 Dimensional Drawings

FWF-BT/BF

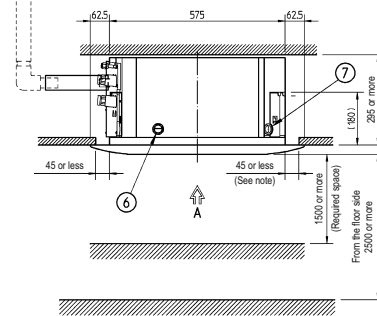
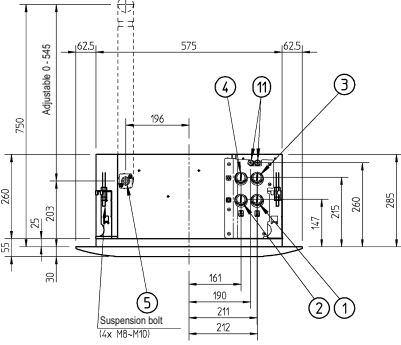
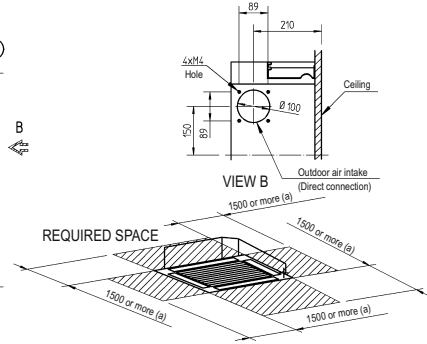
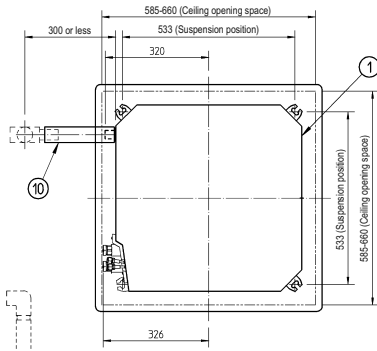
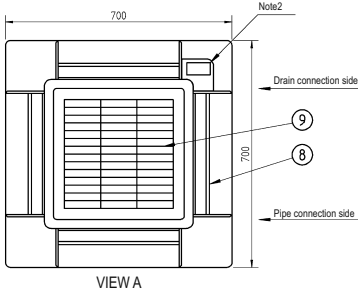

(a) When the discharge grille is covered (by an option kit) the required space is 200mm or more

Nr	Part name	Remark
1	Water pipe connection cooling in	3/4" BSP female (For FWF_B7T: water in)
2	Water pipe connection cooling out	3/4" BSP female (For FWF_B7T: water out)
3	Water pipe connection heating in	3/4" BSP female (For FWF-B7F)
4	Water pipe connection heating out	3/4" BSP female (For FWF-B7F)
5	Drain pipe connection	VP20 (O.D. Ø26)
6	Power supply entry hole	.
7	Transmission wiring entry hole	.
8	Air discharge grille	.
9	Suction grille	.
10	Drain hose (accessory)	1.D.Ø25 (Outlet)
11	Air purge	(1 for FWF_B7T, 2 for FWF_B7F)

DECORATION PANEL

BYFQ60B	White RAL 9010
---------	----------------

3TW33044-1

NOTES

1. Sticking location for manufacturer's label: For indoor unit: on the bell mouth inside suction grille. For decoration panel: on the inner frame inside suction grille.
2. In case of using Infrared remote control, this position will be a signal receiver. Refer to drawing of Infrared remote control for details.
3. When the temperature and humidity in the ceiling exceeds 30°C and RH 80% or the fresh air is inducted into the ceiling or the unit continues 24 hours operation, an additional insulation is required. (Thickness 10mm or more of glaswool or PE foam)
4. Though the installation is acceptable up to maximum of 660 mm square ceiling opening, keep a clearance of 45 mm or less between the main unit and the ceiling opening, so that the panel overlap can be ensured.

7 Dimensional drawings

7 - 2 Dimensional Drawings with Accessories

FWF-BT-BF

VIEW A

①

②

③

A

Dimension between the ceiling surface of indoor unit and the surface of ceiling

40 Thickness of panel spacer

ITEM	PART NAME	REMARK
1	Indoor unit	-
2	Decoration panel	-
3	Panel spacer	-

NOTE

1. Number of pipe connections and air purges is depending om model type.

3TW33044-2

2
7

8 Centre of gravity

8 - 1 Centre of Gravity

FWF-BT/BF

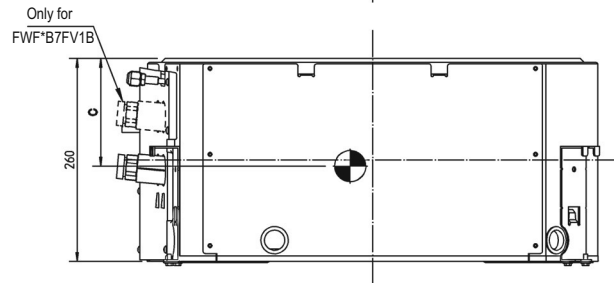
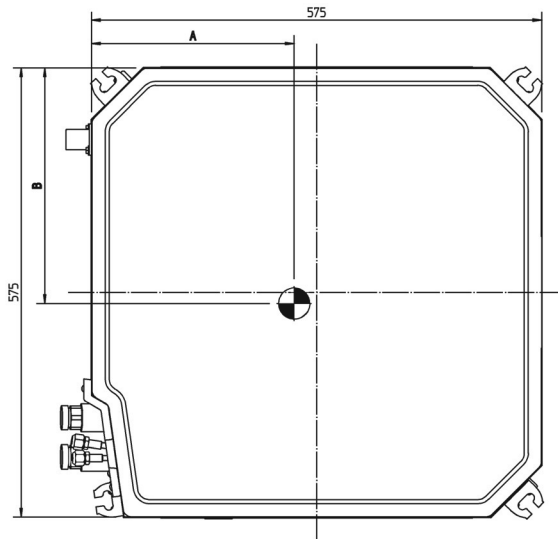

Model	A	B	C
FWF02B7TV1B	259	295	133
FWF02B7FV1B	256	300	132
FWF03-05B7TV1B	267	301	130
FWF03-05B7FV1B	257	312	135

4TW33044-3

9 Piping diagrams

9 - 1 Piping Diagrams

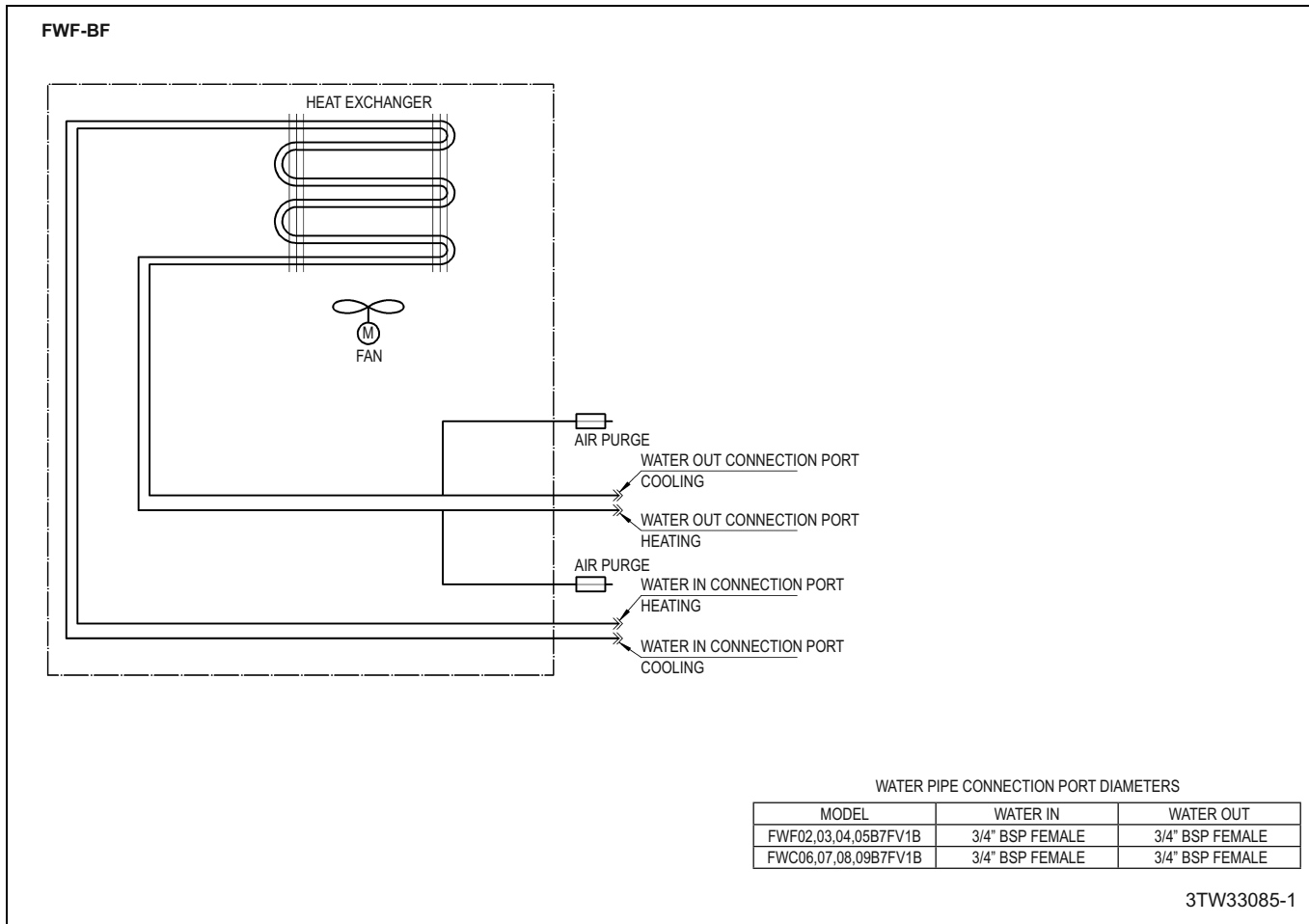

10 Wiring diagrams

10 - 1 Wiring Diagrams - Single Phase

2
10

FWF-BT/BF

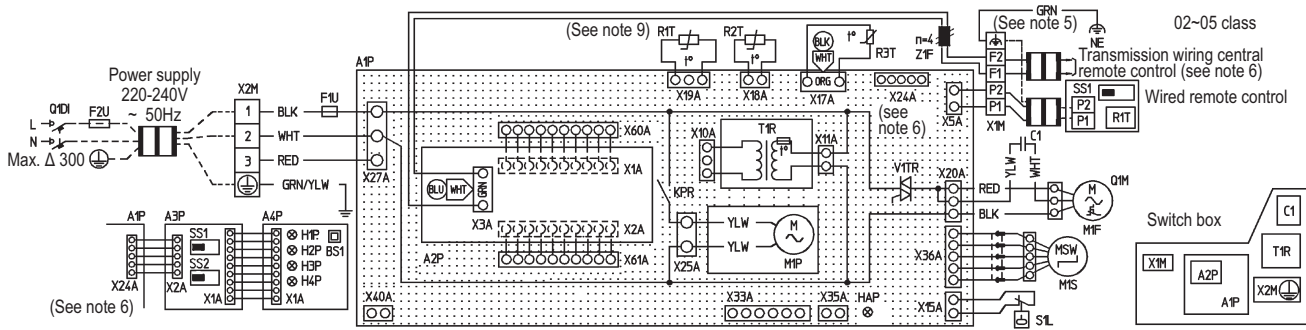

A1P	Printed circuit board	T1R	Transformer (220-240V/22V)	H3P	Light emitting diode (filter sign - red)
A2P	Printed circuit board	V1TR	Phase control circuit	H4P	Light emitting diode (defrost - orange)
C1	Capacitor (M1F)	X1M	Terminal strip	SS1	Selector switch (main/sub)
F1U	Fuse (F5A, 250V)	X2M	Terminal strip	SS2	Selector switch (wireless address set)
F2U	Field fuse	Z1F	Ferrite core	Connector for optional parts	
HAP	Light emitting diode (service monitor green)	TC	Signal transmission circuit	X24A	Connector (infrared remote control)
KPR	Magnetic relay (M1P)	Wired remote control		X33A	Connector (valve control adapter)
M1F	Motor (indoor fan)	R1T	Thermistor (air)	X35A	Connector (external adapter)
M1P	Motor (drain pump)	SS1	Selector switch (main/sub)	X40A	Connector (on/off input from outside)
M1S	Motor (swing flap)	Infrared remote control (receiver/display unit)			
Q1M	Thermo switch (M1F embedded)	A3P	Printed circuit board		
Q1D1	Field earth leak detector (max 300mA)	A4P	Printed circuit board		
R1T	Thermistor (air)	BS1	Push button (on/off)		
R2T	Thermistor	H1P	Light emitting diode (on - red)		
R3T	Thermistor	H2P	Light emitting diode (timer - green)		
S1L	Float switch				

RED: red	YLW: yellow
BLK: black	GRN: green
WHT: white	BLU: blue
ORG: orange	

3TW33046-1

NOTES

- : color of wire, ◻ (marked) color of wire connector, ◻ color of PCB connector
- ◻ : terminal, ◻ : connector, ◻ : wire connector, ◻ : field wiring
- In case using a remote control, connect it to the unit in accordance to the attached installation manual.
- Remote control model varies according to the combination system. See technical data and catalogs, etc. before connecting.
- Ground the shield of the remote control wire to the indoor unit. (In case of using shield wire)
- When using central remote control, see manual for connection to the unit.
- X24A, X33A, X35A and X40A are connected, when optional accessories are being used.
- X24A is connected, when the infrared remote control is being used.
- Availability of R2T and/or R3T is depending on model type.

11 Sound data

11 - 1 Sound Power Spectrum

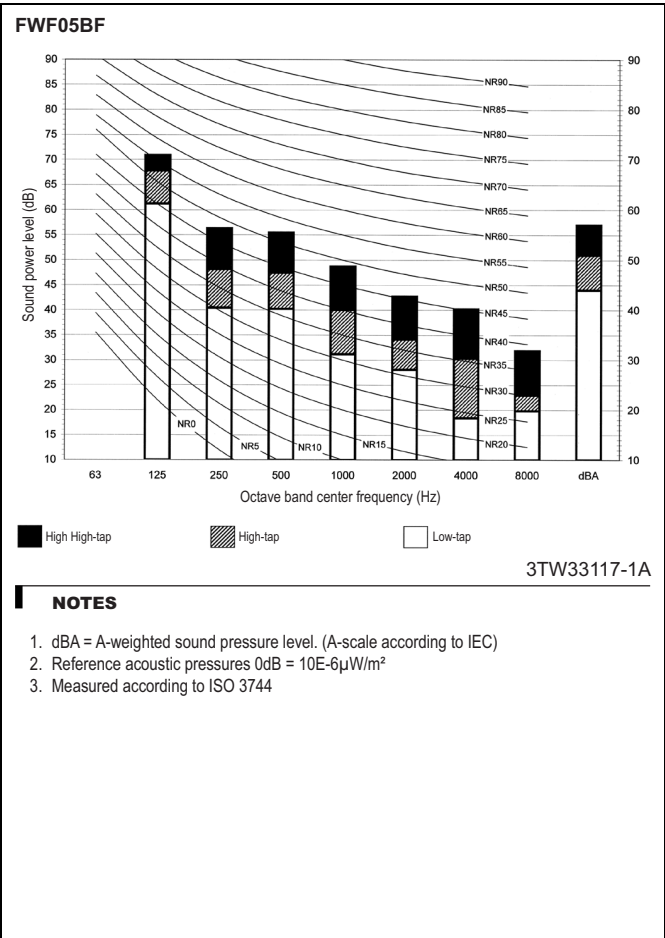
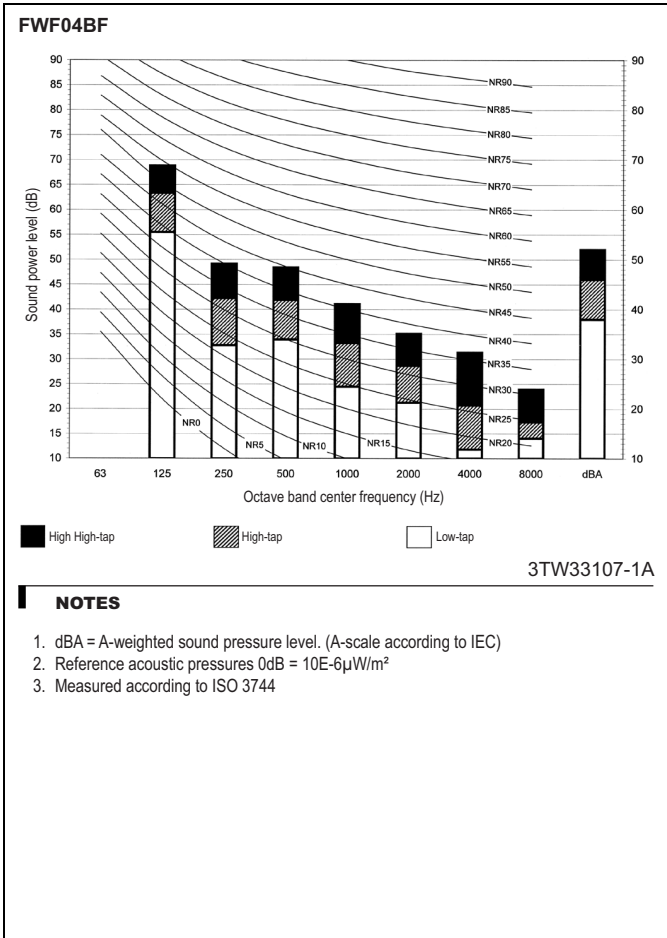
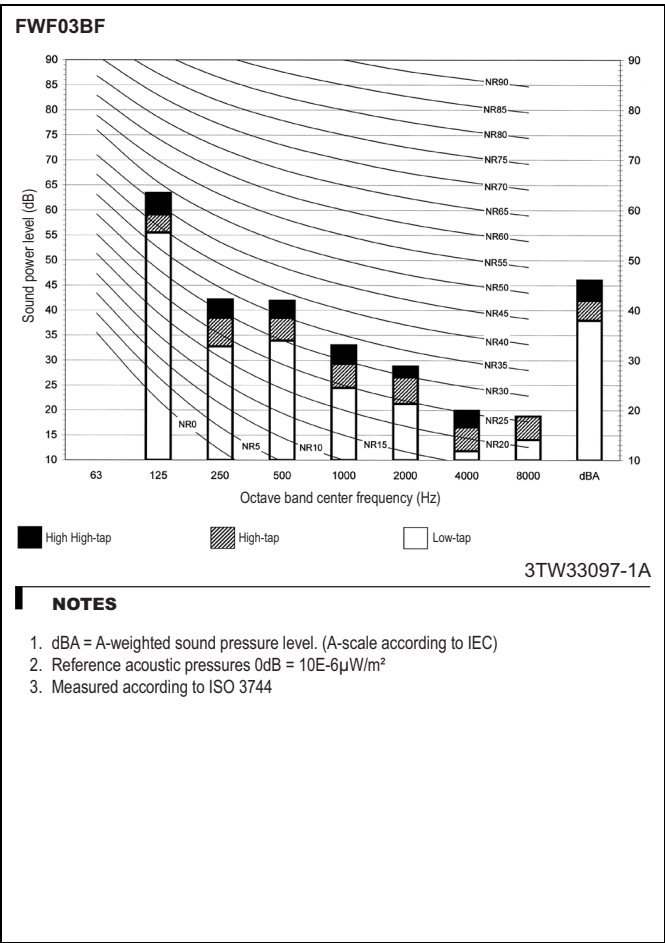
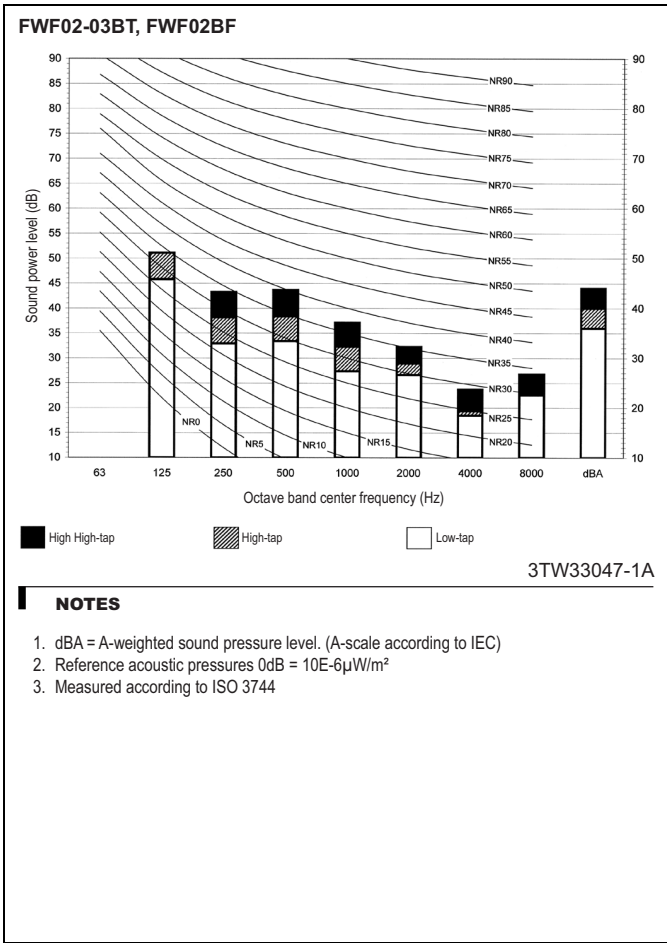

11 Sound data

11 - 2 Sound Pressure Spectrum

2
11

FWF02-03BT, FWF02BF

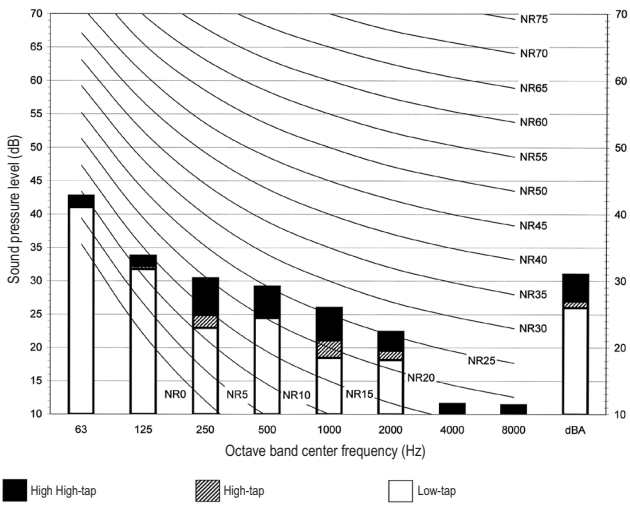

3TW33047-2A

NOTES

1. Data is valid at free field condition
2. Data is valid at nominal operation condition
3. dBA = A-weighted sound pressure level. (A-scale according to IEC)
4. Reference acoustic pressures 0dB = 20μPa
5. Location of microphone.

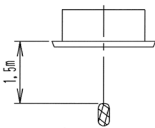

FWF03BF

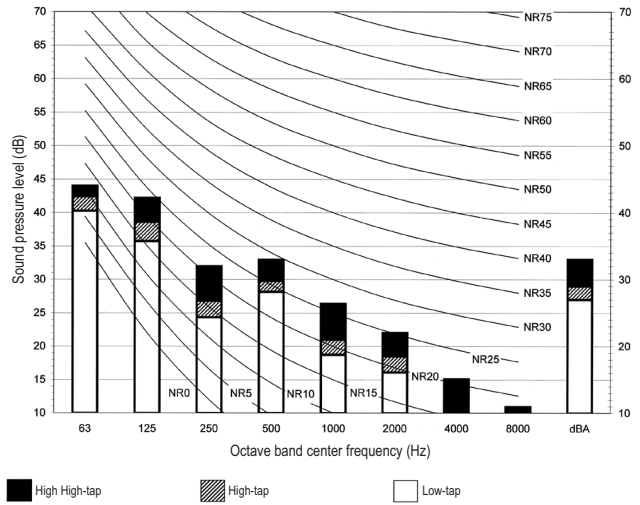

3TW33097-2A

NOTES

1. Data is valid at free field condition
2. Data is valid at nominal operation condition
3. dBA = A-weighted sound pressure level. (A-scale according to IEC)
4. Reference acoustic pressures 0dB = 20μPa
5. Location of microphone.

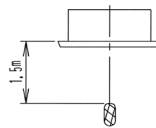

FWF04BF

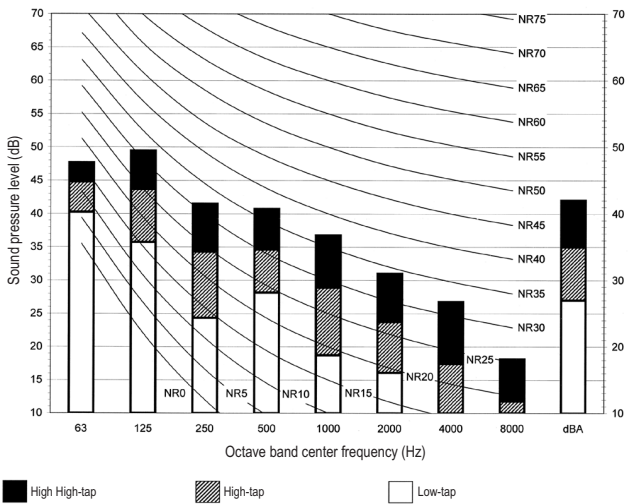

3TW33107-2A

NOTES

1. Data is valid at free field condition
2. Data is valid at nominal operation condition
3. dBA = A-weighted sound pressure level. (A-scale according to IEC)
4. Reference acoustic pressures 0dB = 20μPa
5. Location of microphone.

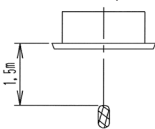

FWF05BF

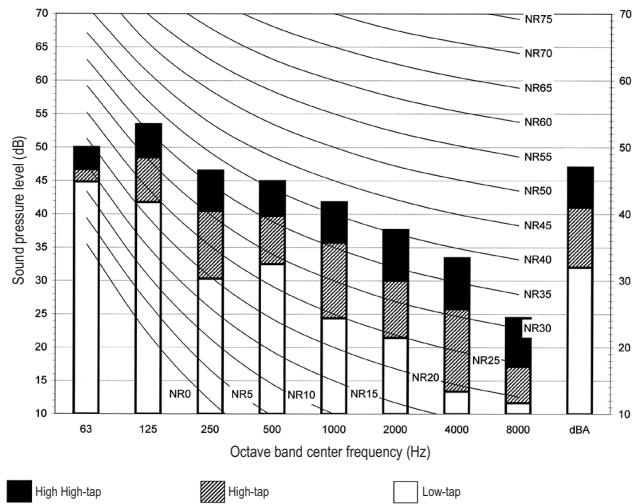

3TW33117-2A

NOTES

1. Data is valid at free field condition
2. Data is valid at nominal operation condition
3. dBA = A-weighted sound pressure level. (A-scale according to IEC)
4. Reference acoustic pressures 0dB = 20μPa
5. Location of microphone.

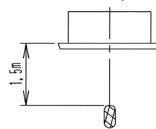

12 Hydraulic performance

12 - 1 Water Pressure Drop Curve Evaporator

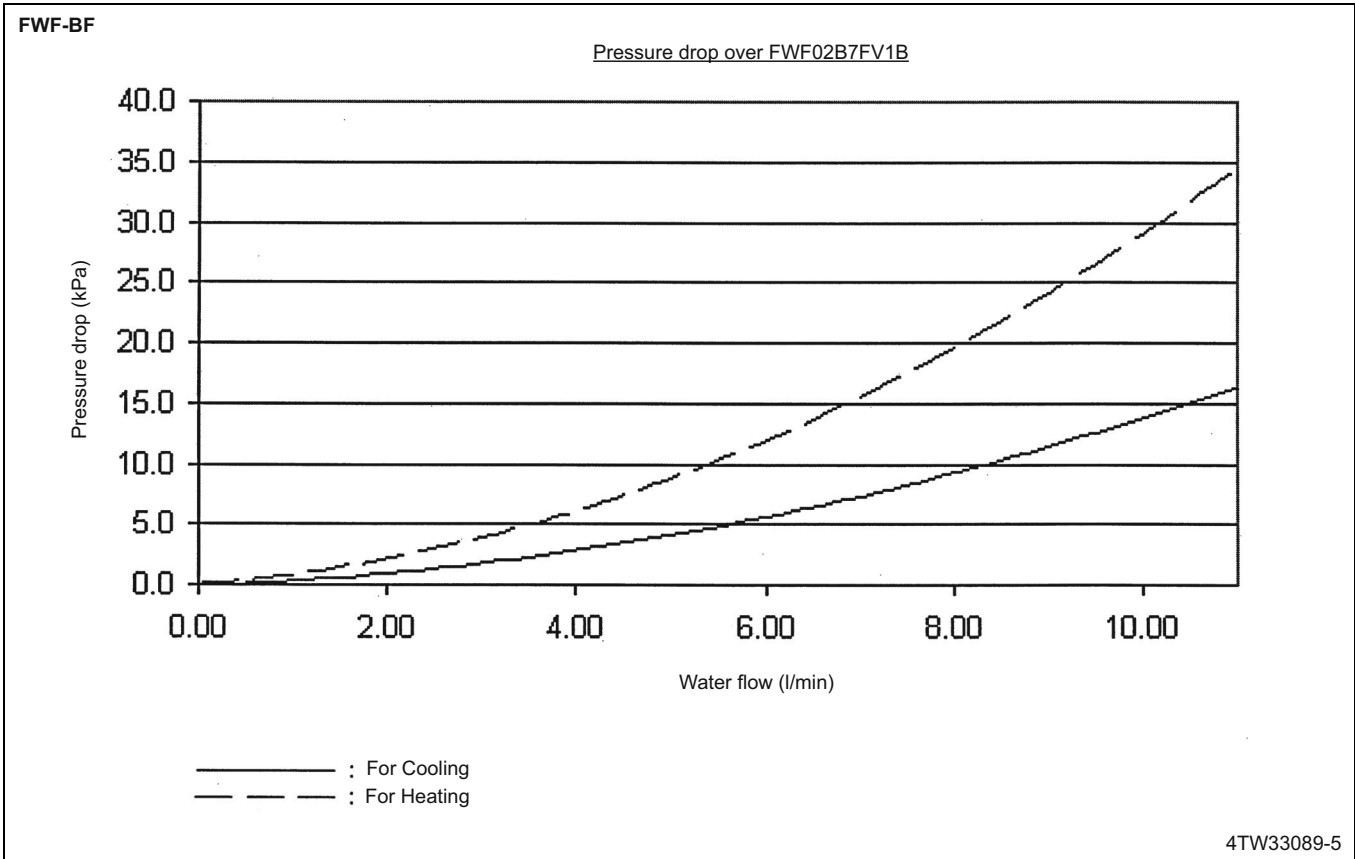

NOTE
1. This graph can be used to calculate the pressure drop over the fan coil unit. The pressure drop over the valve is not included.

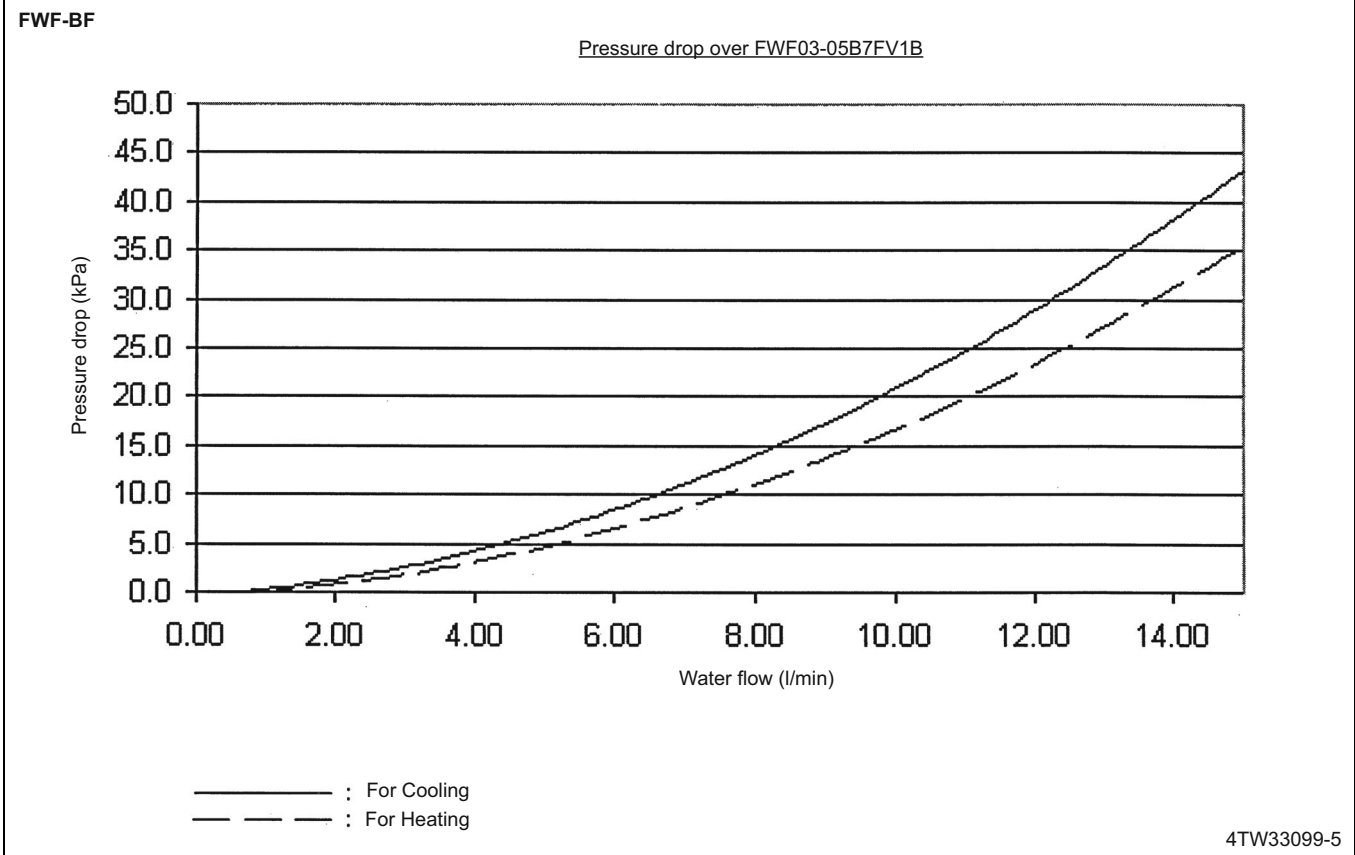

NOTE
1. This graph can be used to calculate the pressure drop over the fan coil unit. The pressure drop over the valve is not included.

In all of us,
a green heart



Daikin's unique position as a manufacturer of air conditioning equipment, compressors and refrigerants has led to its close involvement in environmental issues. For several years Daikin has had the intention to become a leader in the provision of products that have limited impact on the environment. This challenge demands the eco design and development of a wide range of products and an energy management system, resulting in energy conservation and a reduction of waste.



Daikin Europe NV, participates in the Eurovent Certification programme for Air conditioners (AC), Liquid Chilling Packages (LCP) and Fan coil units (FCU). Check ongoing validity of certificate online: www.eurovent-certification.com or using: www.certiflash.com

The present publication is drawn up by way of information only and does not constitute an offer binding upon Daikin Europe N.V. Daikin Europe N.V. has compiled the content of this publication to the best of its knowledge. No express or implied warranty is given for the completeness, accuracy, reliability or fitness for particular purpose of its content and the products and services presented therein. Specifications are subject to change without prior notice. Daikin Europe N.V. explicitly rejects any liability for any direct or indirect damage, in the broadest sense, arising from or related to the use and/or interpretation of this publication. All content is copyrighted by Daikin Europe N.V.



Daikin products are distributed by:

