

Chillers

Commercial and Technical Data

Condenserless chiller

- » **Wide capacity range (110kW – 530kW)**
- » **Ecological R-134a refrigerant**
- » **Compact design**
- » **Water supply down to -10°C (optional)**
- » **New MicroTech III controller**

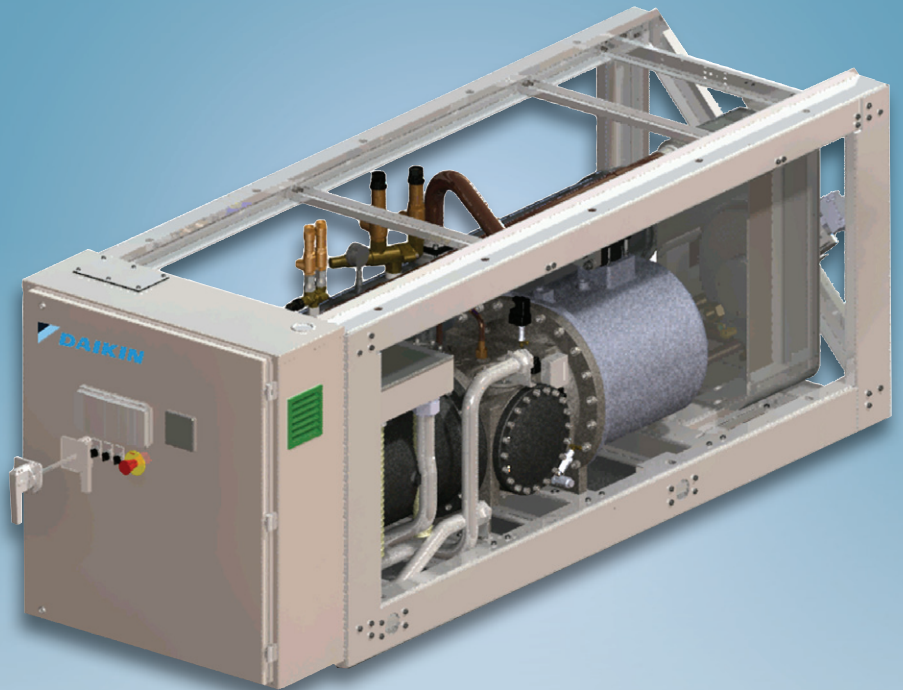

ECDEN11-423

EWLD~J-
110~530 kW

R-134a



Daikin Europe N.V.

About Daikin

Daikin has a worldwide reputation based on over 85 years' experience in the successful manufacture of high quality air conditioning equipment for industrial, commercial and residential use. Daikin's much envied quality quite simply stems from the close attention paid to design, production and testing, as well as aftersales support. To this end, every component is carefully selected and rigorously tested to verify its contribution to product quality and reliability.

New Daikin Compact line 'EWLD-J-' condenserless chiller range

In order to upgrade the water cooled chiller portfolio, Daikin enhances today the 'EWLD-J-' series, offering compact design, maximum efficiency and superior control logic.

The new range is composed of 16 sizes and available in standard efficiency version, with EER up to 3.63. Each unit is equipped with one or two R-134 refrigerant circuits, featuring plate to plate evaporator and single screw compressor with stepless capacity control, allowing the chiller to modulate its capacity from 100% to 12.5%.

Moreover, the range features an extensive option list including the automatic circuit breakers, the energy meter and the sound proof system.



Table of Contents

CHILLER FEATURES	2
TECHNICAL DATA	5
1. Features and advantages	2
2. General characteristics	3
3. Nomenclature	4
4. Technical & electrical specifications	5
5. Sound Levels	6
6. Operating limits	7
7. Standard rating	8
8. Evaporator pressure drop	9
9. Options	10
10. Dimensions	11
11. Installation notes	12
12. Specification (for tender)	13



Chiller features

Application flexibility

The EWLD-J- series is available in a wide range of capacities (110 - 530kW), allowing project solutions for an extensive range of applications. The most commonly serviced parts are easily accessible, simplifying maintenance and service. Moreover, the new chillers allow flexible integration into a wide range of control and building management systems.

Large operation range

With the 'brine' option the new range is able to provide water down to -10°C , making the units suitable for some typical industrial applications.

Extensive option list

The base model includes several standard factory mounted options such as: electronic expansion valve, main switch interlock, emergency stop, etc. Moreover, the new range features an extensive option list, including the sound proof system, the compressor thermal relays, the soft starter, etc.

Superior control logic

The new MicroTech III controller provides an easy to use control environment. The control logic is designed to provide maximum efficiency, to continue operation in unusual operating conditions and to provide a history of unit operation. One of the greatest benefits is the easy interface with Lonwork, BACnet, Ethernet TCP/IP or Modbus communications.

TABLE OF CONTENTS

EWLD-J-SS

1	Features	2
2	Specifications	3
	Technical Specifications	3
	Electrical Specifications	5
3	Features and advantages	7
	Features and Advantages	7
4	General Characteristics	9
	General characteristics	9
5	Nomenclature	13
	Nomenclature	13
6	Capacity tables	14
	Cooling Capacity Tables	14
7	Pressure drops	20
	Evaporator Pressure Drops	20
8	Dimensional drawings	21
	Dimensional Drawings	21
9	Sound data	23
	Sound Level Data	23
10	Installation	24
	Installation Method	24
	Water Charge, Flow and Quality	25
11	Operation range	27
	Operation Range	27
12	Specification text	30
	Specification Text	30

1 Features

- Compact design to allow easy indoor installation or retrofit operations
- Chilled water temperatures down to -10°C on standard unit
- Daikin semi-hermetic single screw stepless compressor
- Optimised for use with R-134a
- High efficiency at full and partial load
- MicroTech III controller

1

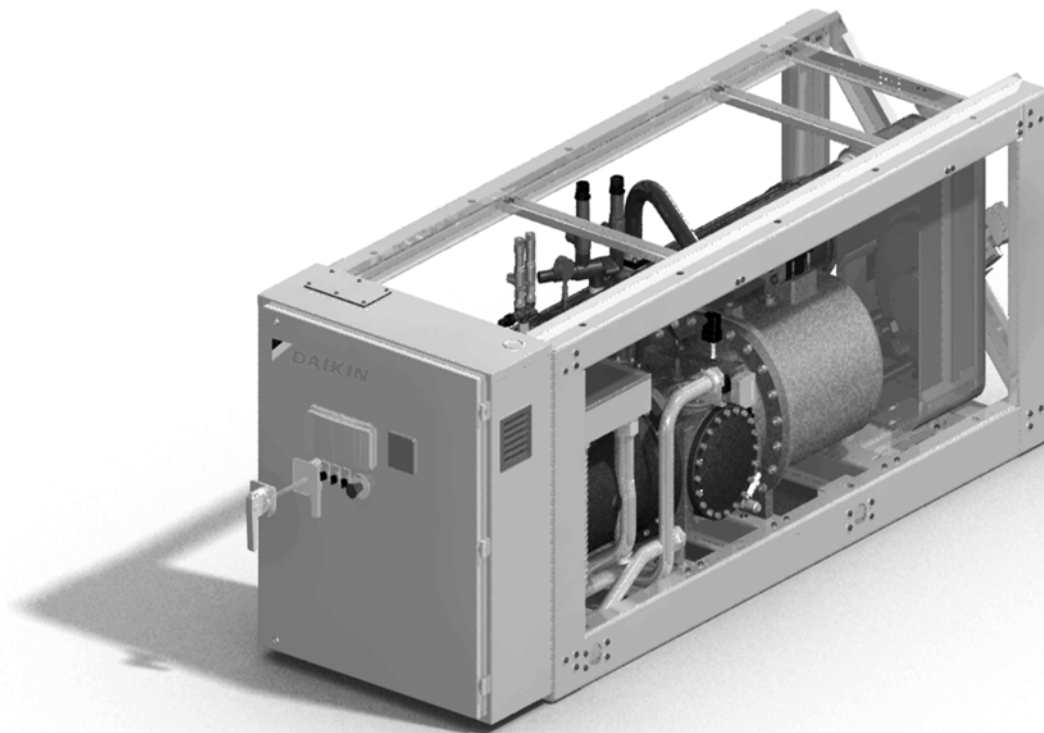

2

2 Specifications

2-1 Technical Specifications				EWLD110J-SS	EWLD130J-SS	EWLD145J-SS	EWLD165J-SS	EWLD195J-SS	EWLD235J-SS		
Cooling capacity	Nom.	kW		110 (1)	128 (1)	143 (1)	164 (1)	192 (1)	237 (1)		
Capacity control	Method			Stepless							
	Minimum capacity			25							
Power input	Cooling	Nom.	kW		30.9 (1)	38.0 (1)	43.3 (1)	49.8 (1)	55.3 (1)	65.2 (1)	
EER				3.55 (1)	3.36 (1)	3.31 (1)	3.30 (1)	3.47 (1)	3.63 (1)		
Casing	Colour			Ivory white							
	Material			Galvanized and painted steel sheet							
Dimensions	Unit	Height	mm		1,020						
		Width	mm		913						
		Depth	mm		2,684						
Weight	Unit		kg		1,124	1,141	1,237	1,263	1,305	1,489	
	Operation weight		kg		1,138	1,159	1,253	1,281	1,327	1,518	
Water heat exchanger - evaporator	Water volume		l		14	18	14	17	20	26	
	Water flow rate	Nom.	l/s		5.24	6.10	6.84	7.84	9.16	11.32	
	Nominal water pressure drop	Cooling	Total	kPa		14	12	36	34	32	25
		Insulation material			Closed cell						
	Type			Brazed plate, one per circuit							
Sound pressure level	Cooling	Nom.	dBA		71.4 (2)				70.0 (2)		
Sound power level	Cooling	Nom.	dBA		88.6 (2)				87.2 (2)		
Compressor	Type			Semi-hermetic single screw compressor							
	Quantity			1							
	Oil	Charged volume		l		13			16		
Operation range	Evaporator	Cooling	Min.	°CDB		-10					
			Max.	°CDB		15					
	Condenser	Cooling	Min.	°CDB		25					
			Max.	°CDB		60					
Refrigerant	Type			R-134a							
	Circuits	Quantity		1							
Piping connections	Liquid line connection		inch		1"3/8						
	Discharge line connection		inch		2"1/8						
	Evaporator water inlet/outlet (OD)			3"							
Safety devices	Item	01		High discharge pressure (pressure switch)							
		02		High discharge pressure (pressure transducer)							
		03		Low suction pressure (pressure transducer)							
		04		Compressor motor protection							
		05		High discharge temperature							
		06		Low oil pressure							
		07		Low pressure ratio							
		08		High oil filter pressure drop							
		09		Phase monitor							
		10		Emergency stop button							
		11		Water freeze protection controller							

2-1 Technical Specifications				EWLD265J-SS	EWLD290J-SS	EWLD310J-SS	EWLD330J-SS	EWLD360J-SS	EWLD390J-SS	
Cooling capacity	Nom.	kW		265 (1)	286 (1)	307 (1)	328 (1)	356 (1)	383 (1)	
Capacity control	Method			Stepless						
	Minimum capacity			25		12.5				
Power input	Cooling	Nom.	kW		74.5 (1)	86.5 (1)	93.0 (1)	99.5 (1)	105 (1)	111 (1)
EER				3.56 (1)	3.31 (1)	3.30 (1)		3.39 (1)	3.47 (1)	
Casing	Colour			Ivory white						
	Material			Galvanized and painted steel sheet						
Dimensions	Unit	Height	mm		1,020	2,000				
		Width	mm		913					
		Depth	mm		2,684					
Weight	Unit		kg		1,489	2,474	2,500	2,526	2,568	2,611
	Operation weight		kg		1,518	2,505	2,533	2,562	2,608	2,655

2 Specifications

2

2-1 Technical Specifications					EWLD265J-SS	EWLD290J-SS	EWLD310J-SS	EWLD330J-SS	EWLD360J-SS	EWLD390J-SS
Water heat exchanger - evaporator	Water volume		l		26	29	31	33	37	41
	Water flow rate	Nom.	l/s		12.65	13.68	14.68	15.69	17.00	18.32
	Nominal water pressure drop	Cooling	Total	kPa	31	36		34		32
					Insulation material					Closed cell
	Type					Braze plate, one per circuit				
Sound pressure level	Cooling	Nom.	dB(A)		70.0 (2)	74.4 (2)				
Sound power level	Cooling	Nom.	dB(A)		87.2 (2)	92.4 (2)				
Compressor	Type				Semi-hermetic single screw compressor					
	Quantity				1	2				
	Oil	Charged volume		l	16	26				
Operation range	Evaporator	Cooling	Min.	°CDB	-10					
			Max.	°CDB	15					
	Condenser	Cooling	Min.	°CDB	25					
			Max.	°CDB	60					
Refrigerant	Type				R-134a					
	Circuits	Quantity			1	2				
Piping connections	Liquid line connection			inch	1"3/8					
	Discharge line connection			inch	2"1/8					
	Evaporator water inlet/outlet (OD)				3"					
Safety devices	Item	01			High discharge pressure (pressure switch)					
		02			High discharge pressure (pressure transducer)					
		03			Low suction pressure (pressure transducer)					
		04			Compressor motor protection					
		05			High discharge temperature					
		06			Low oil pressure					
		07			Low pressure ratio					
		08			High oil filter pressure drop					
		09			Phase monitor					
		10			Emergency stop button					
		11			Water freeze protection controller					

2-1 Technical Specifications					EWLD430J-SS	EWLD470J-SS	EWLD500J-SS	EWLD530J-SS		
Cooling capacity	Nom.			kW	429 (1)	474 (1)	502 (1)	530 (1)		
Capacity control	Method				Stepless					
	Minimum capacity			%	12.5					
Power input	Cooling	Nom.		kW	121 (1)	130 (1)	140 (1)	149 (1)		
EER					3.56 (1)	3.63 (1)	3.59 (1)	3.56 (1)		
Casing	Colour				Ivory white					
	Material				Galvanized and painted steel sheet					
Dimensions	Unit	Height		mm	2,000					
		Width		mm	913					
		Depth		mm	2,684					
Weight	Unit			kg	2,795	2,979				
	Operation weight			kg	2,845	3,036				
Water heat exchanger - evaporator	Water volume		l		46	52				
	Water flow rate	Nom.	l/s		20.47	22.63	23.97	25.30		
	Nominal water pressure drop	Cooling	Total	kPa	32	25		31		
					Insulation material					Closed cell
	Type					Braze plate, one per circuit				
Sound pressure level	Cooling	Nom.	dB(A)		73.8 (2)	73.0 (2)				
Sound power level	Cooling	Nom.	dB(A)		91.8 (2)	91.0 (2)				
Compressor	Type				Semi-hermetic single screw compressor					
	Quantity				2					
	Oil	Charged volume		l	74	76				

4

2 Specifications

2-1 Technical Specifications					EWLD430J-SS	EWLD470J-SS	EWLD500J-SS	EWLD530J-SS
Operation range	Evaporator	Cooling	Min.	°CDB	-10			
			Max.	°CDB	15			
	Condenser	Cooling	Min.	°CDB	25			
			Max.	°CDB	60			
Refrigerant	Type		R-134a					
	Circuits	Quantity		2				
Piping connections	Liquid line connection			inch	1"3/8			
	Discharge line connection			inch	2"1/8			
	Evaporator water inlet/outlet (OD)			3"				
Safety devices	Item	01		High discharge pressure (pressure switch)				
		02		High discharge pressure (pressure transducer)				
		03		Low suction pressure (pressure transducer)				
		04		Compressor motor protection				
		05		High discharge temperature				
		06		Low oil pressure				
		07		Low pressure ratio				
		08		High oil filter pressure drop				
		09		Phase monitor				
		10		Emergency stop button				
		11		Water freeze protection controller				

2

2-2 Electrical Specifications					EWLD110J-SS	EWLD130J-SS	EWLD145J-SS	EWLD165J-SS	EWLD195J-SS	EWLD235J-SS
Compressor	Phase			3~						
	Voltage			V	400					
	Voltage range	Min.		%	-10					
		Max.		%	10					
	Maximum running current			A	80	96	107	121	145	161
	Starting method			Wye-delta						
Power supply	Phase			3~						
	Frequency			Hz	50					
	Voltage			V	400					
	Voltage range	Min.		%	-10					
		Max.		%	10					
	Maximum starting current			A	151		195			288
Unit	Nominal running current (RLA)	Cooling	A	45 (6)	54 (6)	74 (6)	83 (6)	91 (6)	108 (6)	
			A	80	96	107	121	145	161	
Maximum running current			A	88	106	118	133	160	177	
Max unit current for wires sizing			A	88	106	118	133	160	177	

2-2 Electrical Specifications					EWLD265J-SS	EWLD290J-SS	EWLD310J-SS	EWLD330J-SS	EWLD360J-SS	EWLD390J-SS
Compressor	Phase			3~						
	Voltage			V	400					
	Voltage range	Min.		%	-10					
		Max.		%	10					
	Maximum running current			A	182	107	121		145	
	Starting method			Wye-delta						
Power supply	Phase			3~						
	Frequency			Hz	50					
	Voltage			V	400					
	Voltage range	Min.		%	-10					
		Max.		%	10					
	Maximum starting current			A	288	281	292		311	
Unit	Nominal running current (RLA)	Cooling	A	123 (6)	147 (6)	156 (6)	166 (6)	174 (6)	182 (6)	
			A	182	214	228	242	266	290	
Maximum running current			A	200	235	251	266	293	319	
Max unit current for wires sizing			A	200	235	251	266	293	319	

2 Specifications

2

2-2 Electrical Specifications			EWLD430J-SS	EWLD470J-SS	EWLD500J-SS	EWLD530J-SS
Compressor	Phase		3~			
	Voltage		V			
	Voltage range	Min.	%			
		Max.	%			
	Maximum running current		A	145	161	182
	Starting method		Wye-delta			
Power supply	Phase		3~			
	Frequency		Hz			
	Voltage		V			
	Voltage range	Min.	%			
		Max.	%			
	Maximum starting current		A	404	417	434
Nominal running current (RLA)	Cooling	A	199 (6)	216 (6)	231 (6)	246 (6)
		A	306	322	343	364
Max unit current for wires sizing		A	337	354	377	400.4

Notes

- (1) Cooling: entering evaporator water temp. 12°C; leaving evaporator water temp. 7°C; saturated discharge temp. 45°C, unit at full load operation
- (2) Sound level data are measured at entering evaporator water temp. 12°C; leaving evaporator water temp. 7°C; saturated discharge temp. 45°C; full load operation; standard: ISO3744
- (3) Units are shipped with holding nitrogen charge at 2 bar
- (4) Allowed voltage tolerance $\pm 10\%$. Voltage unbalance between phases must be within $\pm 3\%$.
- (5) Maximum starting current: starting current of biggest compressor + current of the other compressor at 75 % of maximum load
- (6) Nominal current in cooling mode: entering evaporator water temp. 12°C; leaving evaporator water temp. 7°C; saturated discharge temperature 45°C
- (7) Maximum running current is based on max compressor absorbed current in its envelope
- (8) Maximum unit current for wires sizing is based on minimum allowed voltage.
- (9) Maximum current for wires sizing: compressor full load ampere x 1.1

3 Features and advantages

3 - 1 Features and Advantages

Features and advantages

The EWLD-J- water cooled chillers, featuring 1 or 2 single screw compressors, are manufactured to satisfy the requirements of the consultants and the end user. Units are designed to minimise energy costs while maximising the refrigeration capacities.

Daikin's chiller design experience, combined with outstanding features makes the EWLD-J- chiller unmatched in the industry.

Seasonal quietness

The compressor design with a single screw and twin rotors allows a constant gas flow. This compression process completely eliminates gas pulsations. The oil injection also results in significant mechanical noise reduction. The twin gas compressor discharge chambers are designed to act as attenuators, based on the harmonic wave principle with destructive interference, thus always resulting equal to zero. The extremely low noise compressor performance affords the use of EWLD-J- chiller for all applications. The reduced number of vibrations produced from the EWLD-J- chiller offers a surprisingly quiet operation eliminating the noise transmission through the structure and the chilled water piping system.

Infinitely capacity control

Cooling capacity control is infinitely variable by means of a screw compressor controlled by microprocessor system. Each unit has infinitely variable capacity control from 100% down to 25% (one compressor unit), down to 12,5% (two compressors units). This modulation allows the compressor capacity to exactly match the building cooling load without any leaving evaporator water temperature fluctuation. This chilled water temperature fluctuation is avoided only with a stepless control.

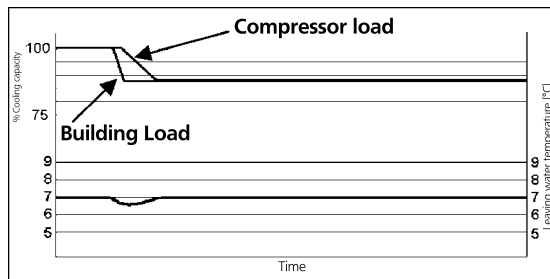

EWLT fluctuation with stepless capacity control

With a compressor load step control in fact, the compressor capacity, at partial loads, will be too high or too low compared to the building cooling load. The result is an increase in chiller energy costs, particularly at the part-load conditions at which the chiller operates most of the time.

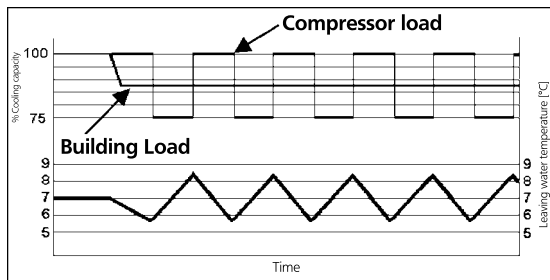

EWLT fluctuation with steps capacity control (4 steps)

Units with stepless regulation offer benefits that the units with step regulation are unable to match. The ability to follow the system energy demand at any time and the possibility to provide steady outlet water temperature without deviations from the set-point, are the two points that allow you to understand how the optimum operating conditions of a system can be met only through the use of a unit with step-less regulation.

Code requirements - Safety and observant of laws/directives

All water cooled units are designed and manufactured in accordance with applicable selections of the following:

Construction of pressure vessel	97/23/EC (PED)
Machinery Directive	2006/42/EC
Low Voltage	2006/95/EC
Electromagnetic Compatibility	2004/108/EC
Electrical & Safety Codes	EN 60204-1/EN 60335-2-40
Manufacturing Quality Stds	UNI - EN ISO 9001:2004

FTA_1-2_Rev.00_1

3 Features and advantages

3 - 1 Features and Advantages

3

Certifications

All units manufactured are CE marked, complying with European directives in force, concerning manufacturing and safety. On request units can be produced complying with laws in force in non European countries (ASME, GOST, etc.), and with other applications, such as naval (RINA, etc.).

Versions

EWLD-J- is available in standard efficiency version:

S: Standard Efficiency

16 sizes, covering a cooling capacity range from 110 up to 530 kW, EER up to 3.63

The EER (Energy Efficiency Ratio) is the ratio of the Cooling Capacity to the Power Input of the unit. The Power Input includes: the power input for operation of the compressor, the power input of all control and safety devices.

Sound configuration

EWLD-J- is available in standard sound level configuration:

S: Standard Noise

FTA_1-2_Rev.00_2

4 General Characteristics

4 - 1 General characteristics

General characteristics

Cabinet and structure

The cabinet is made of galvanized steel sheet and painted to provide a high resistance to corrosion. Colour Ivory White (Munsell code 5Y7.5/1) (\pm RAL7044). The base frame has eye-hook for lifting the unit with ropes for an easy installation. The weight is uniformly distributed along the profiles of the base and this facilitates the arrangement of the unit.

Screw compressors

The compressor is semi-hermetic, single-screw type with gate-rotors made of carbon impregnated engineered composite material. The compressor has one slide managed by the unit microprocessor for infinitely modulating the capacity between 100% to 25%. An integrated high efficiency oil separator maximizes the oil separation and standard start is Wye-delta (Y- Δ) type.

Ecological R-134a refrigerant

The compressors have been designed to operate with R-134a, ecological refrigerant with zero ODP (Ozone Depletion Potential) and very low GWP (Global Warming Potential) that means low TEWI (Total Equivalent Warming Impact).

Evaporator

The units are equipped with direct expansion plate to plate type evaporator, one per circuit. This heat exchanger is made of stainless steel brazed plates and is covered with a 10mm closed cell insulation material. The evaporator is manufactured in accordance to PED approval. The evaporator water outlet connections are provided with Victaulic Kit (as standard).

Electronic expansion valve

The unit is equipped with the most advanced electronic expansion valves to achieve precise control of refrigerant mass flow. As today's system requires improved energy efficiency, tighter temperature control, wider range of operating conditions and incorporate features like remote monitoring and diagnostics, the application of electronic expansion valves becomes mandatory.

Electronic expansion valve proposes features that makes it unique: short opening and closing time, high resolution, positive shut-off function to eliminate use of additional solenoid valve, highly linear flow capacity, continuous modulation of mass flow without stress in the refrigerant circuit and corrosion resistance stainless steel body.

EEV strength point is the capacity to work with lower Δ P between high and low pressure side, than a thermostatic expansion valve. The electronic expansion valve allows the system to work with low condenser pressure (winter time) without any refrigerant flow problems and with a perfect chilled water leaving temperature control.

Refrigerant circuit

Each unit has independent refrigerant circuits and each one includes:

- Single screw compressor with integrated oil separator
- Brazed plate evaporator
- Oil pressure transducer
- High pressure switches
- High pressure transducer
- Low pressure transducer
- Moisture liquid indicator
- Replaceable core filter-drier
- Electronic expansion valve

GNC_1-2-3-4_Rev.00_1

4 General Characteristics

4 - 1 General characteristics

Electrical control panel

Power and control are located in the main panel that is manufactured to ensure protection against all weather conditions. The electrical panel is IP54 and (when opening the doors) internally protected with Plexiglas panel against possible accidental contact with electrical components (IP20). The main panel is fitted with a main switch interlocked door.

Power section

The power section includes compressors fuses and control circuit transformer.

MicroTech III controller

MicroTech III controller is installed as standard; it can be used to modify unit set-points and check control parameters. A built-in display shows chiller operating status plus temperatures and pressures of water, refrigerant, programmable values, set-points. A sophisticated software with predictive logic, selects the most energy efficient combination of compressors and electronic expansion valve to keep stable operating conditions to maximise chiller energy efficiency and reliability. MicroTech III is able to protect critical components based on external signs from its system (such as motor temperatures, refrigerant gas and oil pressures, correct phase sequence, pressure switches and evaporator). The input coming from the high pressure switch cuts all digital output from the controller in less than 50ms, this is an additional security for the equipment. Fast program cycle (200ms) for a precise monitoring of the system. Floating point calculations supported for increased accuracy in P/T conversions.

Control section - main features:

- Management of the compressor stepless capacity.
- Chiller enabled to work in partial failure condition.
- Full routine operation at condition of:
 - high ambient temperature value
 - High thermal load
 - High evaporator entering water temperature (start-up)
- Display of evaporator entering/leaving water temperature.
- Display of condensing-evaporating temperature and pressure, suction and discharge superheating temperature for each circuit.
- Leaving water evaporator temperature regulation. Temperature tolerance = 0,1°C.
- Compressor and evaporator pumps hour counters.
- Display of Status Safety Devices.
- Number of starts and compressor working hours.
- Optimized management of compressor load.
- Re-start in case of power failure (Automatic / Manual).
- Soft Load (optimized management of the compressor load during the start-up).
- Start at high evaporator water temperature.
- Return Reset (Set Point Reset based on return water temperature).
- Setpoint Reset (optional).
- Application and system upgrade with commercial SD cards.
- Ethernet port for remote or local servicing using standard web browsers.
- Two different sets of default parameters could be stored for easy restore.

Safety device / logic for each refrigerant circuit

- High pressure (pressure switch).
- High pressure (transducer).
- Low pressure (transducer).
- High compressor discharge temperature.
- High motor winding temperature.
- Phase monitor.
- Low pressure ratio.
- High oil pressure drop.
- Low oil pressure.
- No pressure change at start.

GNC_1-2-3-4_Rev.00_2

4 General Characteristics

4 - 1 General characteristics

System security

- Phase monitor.
- Low Ambient temperature lock-out.
- Freeze protection.

Regulation type

Proportional + integral + derivative regulation on the evaporator leaving water output probe.

Microtech III

MicroTech III built-in terminal has the following features.

- 164x44 dots liquid crystal display with white back lighting. Supports Unicode fonts for multi-lingual.
- Key-pad consisting of 3 keys.
- Push'n'Roll control for an increased usability.
- General faults alarm relays.
- General faults alarm led.
- Password access to modify the setting.
- Application security to prevent application tampering or hardware usability with third party applications.
- Service report displaying all running hours and general conditions.
- Alarm history memory to allow an easy fault analysis.

Supervising systems (on request)

MicroTech III remote control

MicroTech III is able to communicate to BMS (Building Management System) based on the most common protocols as:

- ModbusRTU
- LonWorks, now also based on the international 8040 Standard Chiller Profile and LonMark Technology.
- BacNet BTP certified over IP and MS/TP (class 4) (Native).

Chiller Sequencing

MicroTech III controller allows an easy plug-in sequencing technology based on digital or serial panel

Digital Sequencing Panel

This panel is basically a step inserter that switches ON/OFF up to 11 units (chillers or heat pumps operating in the same cooling/heating mode) depending on the selected set point, the units are connected with the panel through standard cables and no serial card is requested.

Serial Sequencing Panel

Basically this panel sequences a chiller plant by switching on/off the units (up to 7 chillers) taking into account their running hours and the requested plant load, in order to optimise the number of working units for each condition; serial cards and shielded cables are requested to connect the panel with the units and, if installed, a BMS.

Standard accessories (supplied on basic unit)

Evaporator Victaulic Kit - Hydraulic joint with gasket for an easy and quick water connection.

20mm Evaporator Insulation

Suction line shut off valve - Suction shut-off valve installed on the suction of the compressor to facilitate maintenance operation.

Discharge line shut-off valves - Discharge shut-off valve installed on the discharge of the compressor to facilitate maintenance operations.

Electronic expansion valve

GNC_1-2-3-4_Rev.00_3

4 General Characteristics

4 - 1 General characteristics

4

High Pressure Side Manometers

Y-D starter - Star Delta starter is the standard type

Double set-point - Dual leaving water temperature set-points.

Phase monitor - The phase monitor controls that phases sequence is correct and controls phase loss.

Evaporator flow switch for the water piping.

Hour run meter - Digital compressors hour run meter.

General fault contactor - Contactor for alarm warning.

Main switch interlock

Emergency stop

Options (on request)

Brine version - Allows the unit to operate down to -8°C leaving liquid temperature (antifreeze required).

Compressor thermal overload relays - Safety devices against compressor motor overloading in addition to the normal protection envisaged by the electrical windings.

Evaporator Water side design pressure 16 bar

Water pressure differential switch on evaporator

Sound Proof System - Compressor sound enclosure.

Rubber type antivibration mounts - Supplied separately, these are positioned under the base of the unit during installation. Ideal to reduce the vibrations when the unit is floor mounted.

Fork lift kit

Low pressure side manometers

Dual Pressure Relief Valve on evaporator

Under/Over Voltage - This device control the voltage value of power supply and stop the chiller if the value exceeds the allowed operating limits.

Energy Meter - This device allows to measure the energy absorbed by the chiller during its life.

It is installed inside the control box mounted on a DIN rail and show on a digital display: Line-to-Line Voltage, Phase and Average Current, Active and Reactive Power, Active Energy, Frequency.

Current limit display

Witness test - Every unit is always tested at the test bench prior to the shipment. On request, a second test can be carried out, at customer's presence, in accordance with the procedures indicated on the test form. (Not available for units with glycol mixtures)

Acoustic test - On request, a test can be carried out, at customer's presence (please contact the factory) (This test is not available for units with glycol mixtures).

Set-point reset, demand limit and alarm from external device - The leaving water temperature set-point can be overwritten with the following options: 4-20mA from external source (by user), outside ambient temperature; evaporator water temperature Δt . Moreover the device allow the user to limit the load of the unit by 4-20mA signal or by network system and the microprocessor is able to receive an alarm signal from an external device (pump etc... - user can decide if this alarm signal will stop or not the unit).

Automatic circuit breakers

GNC_1-2-3-4_Rev.00_4

5 Nomenclature

5 - 1 Nomenclature

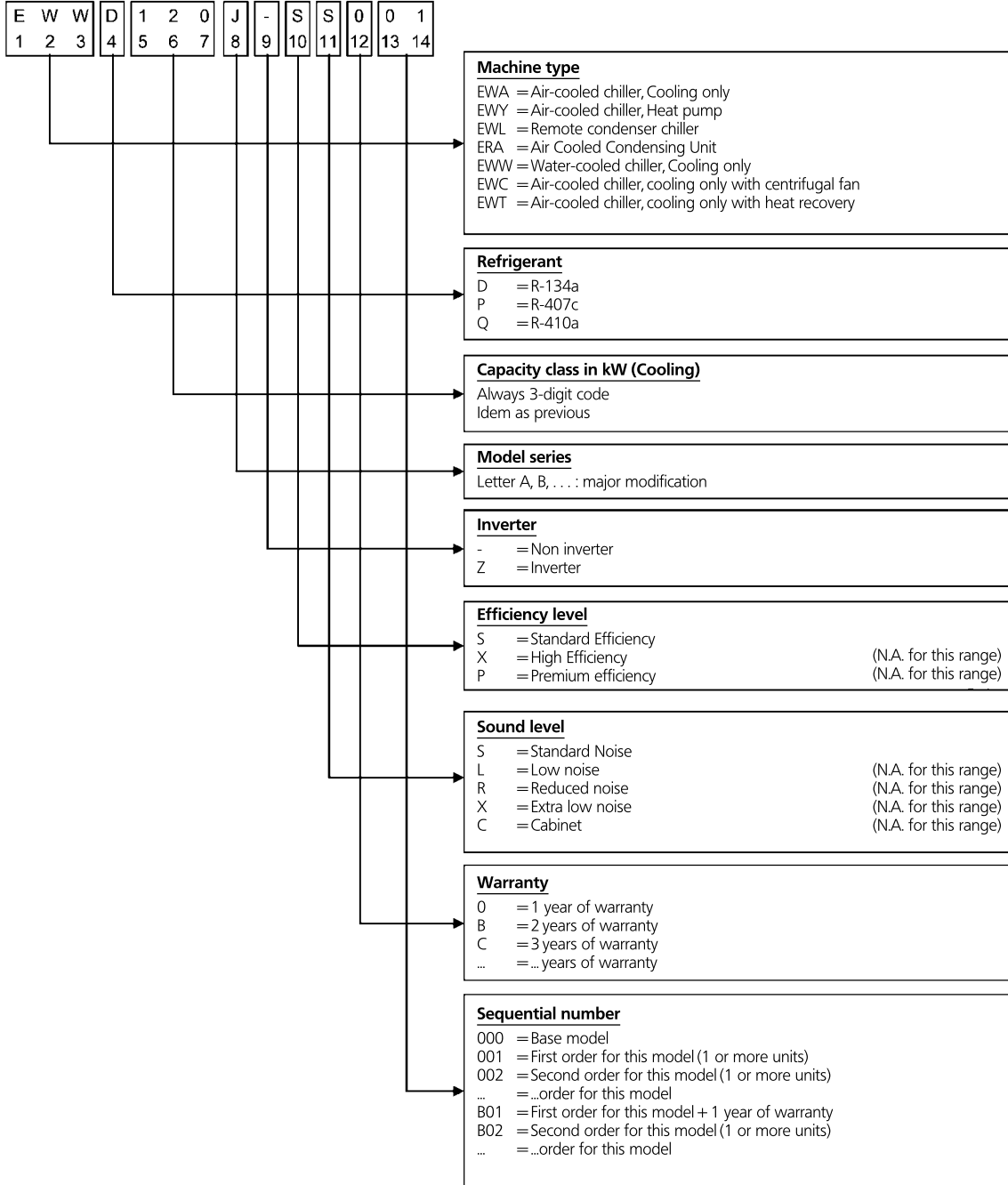

6 Capacity tables

6 - 1 Cooling Capacity Tables

EWLD110-235J-SS

Unit	EWLT (°C)	Saturated discharge temperature °C												
		25			30			35			40			
		Cc (kW)	Pi (kW)	Hc (kW)	Cc (kW)	Pi (kW)	Hc (kW)	Cc (kW)	Pi (kW)	Hc (kW)	Cc (kW)	Pi (kW)	Hc (kW)	
110	4	117	20.4	137	113	22.5	135	108	24.8	133	103	27.4	131	
	5	121	20.6	142	117	22.7	139	112	25.0	137	107	27.6	135	
	6	125	20.8	146	121	22.9	144	116	25.2	141	111	27.8	139	
	7	129	21.0	150	125	23.1	148	120	25.5	146	115	28.0	143	
	8	133	21.2	155	129	23.4	152	124	25.7	150	119	28.3	147	
	9	138	21.5	159	133	23.6	157	128	25.9	154	123	28.5	152	
	10	142	21.7	164	137	23.8	161	132	26.2	159	127	28.8	156	
	11	146	21.9	168	142	24.1	166	137	26.4	163	131	29.0	160	
	12	151	22.2	173	146	24.3	170	141	26.7	168	136	29.2	165	
	13	156	22.4	178	151	24.6	175	145	26.9	172	140	29.5	169	
	14	160	22.7	183	155	24.8	180	150	27.2	177	144	29.7	174	
	15	165	22.9	188	160	25.1	185	154	27.4	182	149	30.0	179	
	130	4	136	25.0	161	131	27.7	159	126	30.6	157	120	33.7	154
		5	141	25.3	166	136	28.0	164	130	30.8	161	125	34.0	159
		6	146	25.6	172	141	28.2	169	135	31.1	166	129	34.3	164
7		151	25.9	177	146	28.5	174	140	31.4	171	134	34.5	168	
8		156	26.2	182	151	28.8	180	145	31.7	177	139	34.8	174	
9		162	26.5	188	156	29.1	185	150	32.0	182	144	35.1	179	
10		167	26.8	194	161	29.4	191	155	32.3	187	149	35.4	184	
11		172	27.1	199	166	29.7	196	160	32.6	193	154	35.8	190	
12		178	27.4	205	172	30.0	202	166	32.9	198	159	36.1	195	
13		183	27.7	211	177	30.4	208	171	33.2	204	164	36.4	201	
14		189	28.0	217	183	30.7	213	176	33.6	210	170	36.7	206	
15		195	28.4	223	188	31.0	219	182	33.9	216	175	37.1	212	
145		4	152	28.4	180	147	31.6	178	141	35.0	176	135	38.5	174
		5	156	28.6	185	151	31.9	183	146	35.2	181	140	38.8	179
		6	161	28.9	190	156	32.1	188	151	35.5	186	145	39.1	184
	7	166	29.2	195	161	32.4	193	155	35.8	191	149	39.4	189	
	8	171	29.4	200	165	32.7	198	160	36.0	196	154	39.6	194	
	9	176	29.7	205	170	33.0	203	165	36.3	201	159	39.9	199	
	10	181	30.0	211	175	33.2	208	170	36.6	206	164	40.2	204	
	11	186	30.3	216	180	33.5	214	174	36.9	211	168	40.5	209	
	12	191	30.6	222	185	33.8	219	179	37.2	217	173	40.8	214	
	13	196	30.9	227	191	34.1	225	185	37.5	222	178	41.1	219	
	14	202	31.2	233	196	34.4	230	190	37.8	228	183	41.4	225	
	15	207	31.5	238	201	34.7	236	195	38.1	233	189	41.7	230	
	165	4	174	32.7	207	169	36.2	205	162	40.0	202	155	44.2	199
		5	180	33.0	213	174	36.5	210	168	40.3	208	161	44.5	205
		6	185	33.3	219	179	36.8	216	173	40.7	214	166	44.8	211
7		191	33.6	225	185	37.1	222	179	41.0	220	172	45.2	217	
8		197	34.0	231	191	37.5	228	184	41.3	225	177	45.5	223	
9		203	34.3	237	197	37.8	234	190	41.7	232	183	45.9	229	
10		209	34.6	244	202	38.2	241	196	42.0	238	188	46.2	235	
11		215	35.0	250	208	38.5	247	202	42.4	244	194	46.6	241	
12		221	35.3	257	215	38.9	254	208	42.7	250	200	46.9	247	
13		228	35.7	263	221	39.2	260	214	43.1	257	206	47.3	253	
14		234	36.1	270	227	39.6	267	220	43.5	263	212	47.7	260	
15		241	36.5	277	234	40.0	274	226	43.8	270	218	48.0	266	
195		4	205	35.9	241	197	40.3	237	189	44.7	234	181	49.2	230
		5	212	36.2	248	203	40.6	244	195	45.0	240	188	49.6	237
		6	218	36.5	254	209	41.0	250	202	45.4	247	194	49.9	244
	7	224	36.9	261	216	41.3	257	208	45.7	254	200	50.3	250	
	8	231	37.2	268	222	41.7	264	214	46.1	260	206	50.7	257	
	9	238	37.6	275	229	42.0	271	221	46.4	267	213	51.0	264	
	10	244	38.0	282	235	42.4	278	227	46.8	274	219	51.4	271	
	11	251	38.3	289	242	42.8	285	234	47.2	281	226	51.8	278	
	12	258	38.7	297	249	43.2	292	241	47.6	288	233	52.2	285	
	13	265	39.1	304	256	43.6	300	248	48.0	296	239	52.6	292	
	14	273	39.5	312	263	43.9	307	255	48.4	303	246	53.0	299	
	15	280	39.9	320	271	44.3	315	262	48.8	311	253	53.4	307	
	235	4	254	41.9	296	244	46.8	291	234	52.1	286	225	57.9	283
		5	263	42.2	305	253	47.2	300	242	52.4	295	232	58.2	290
		6	272	42.5	314	262	47.5	309	251	52.8	304	240	58.5	299
7		280	42.7	322	271	47.8	319	260	53.2	313	249	58.9	308	
8		287	43.0	330	279	48.1	327	269	53.6	323	257	59.3	317	
9		295	43.2	339	286	48.4	335	277	53.9	331	266	59.7	326	
10		304	43.4	347	294	48.7	343	285	54.2	339	275	60.1	335	
11		312	43.7	355	302	49.0	351	293	54.5	347	282	60.4	343	
12		320	43.9	364	311	49.2	360	301	54.8	355	290	60.8	351	
13		328	44.1	373	319	49.5	368	309	55.1	364	298	61.1	359	
14		337	44.3	381	327	49.8	377	317	55.5	373	306	61.5	368	
15		346	44.5	390	336	50.0	386	325	55.8	381	315	61.8	376	

NOTES

Cc (cooling capacity) - Pi (unit power input) -Hc (heat rejection) - ELWT (Evaporator leaving water temperature - Δt 5°C)
 Data refers to 0,0176m² °C/kW evaporator fouling factor

CAPCOOL_1-2-3-4-5-6_Rev.00_1

6 Capacity tables

6 - 1 Cooling Capacity Tables

EWLD110~235J-SS

Unit	EWLT (°C)	Saturated discharge temperature °C												
		45			50			55			60			
		Cc(kW)	Pi(kW)	Hc(kW)	Cc(kW)	Pi(kW)	Hc(kW)	Cc(kW)	Pi(kW)	Hc(kW)	Cc(kW)	Pi(kW)	Hc(kW)	
110	4	98.3	30.2	129	93.0	33.2	126	87.4	36.6	124	81.5	40.2	122	
	5	102	30.4	132	96.6	33.5	130	90.8	36.8	128	84.8	40.4	125	
	6	106	30.6	136	100	33.7	134	94.3	37.0	131	88.2	40.7	129	
	7	110	30.9	141	104	33.9	138	98.0	37.3	135	91.6	40.9	133	
	8	114	31.1	145	108	34.2	142	102	37.5	139	95.2	41.1	136	
	9	118	31.3	149	112	34.4	146	106	37.7	143	98.9	41.4	140	
	10	122	31.6	153	116	34.6	150	109	38.0	147	102.7	41.6	144	
	11	126	31.8	158	120	34.9	155	113	38.2	152	106.6	41.8	148	
	12	130	32.1	162	124	35.1	159	117	38.5	156	110.5	42.1	153	
	13	134	32.3	167	128	35.4	164	122	38.7	160	114.5	42.4	157	
	14	139	32.6	171	132	35.7	168	126	39.0	165	118.6	42.6	161	
	15	143	32.8	176	137	35.9	173	130	39.3	169	122.8	42.9	166	
	130	4	114	37.1	151	108	40.9	149	101	45.0	146	94.3	49.4	144
		5	119	37.4	156	112	41.2	153	106	45.3	151	98.3	49.7	148
		6	123	37.7	161	117	41.4	158	110	45.5	155	102.3	50.0	152
7		128	38.0	166	121	41.7	163	114	45.8	160	106.4	50.3	157	
8		132	38.3	171	126	42.0	168	118	46.1	164	110.6	50.5	161	
9		137	38.6	176	130	42.3	172	123	46.4	169	115.0	50.8	166	
10		142	38.9	181	135	42.6	177	127	46.7	174	119.4	51.2	171	
11		147	39.2	186	140	42.9	183	132	47.0	179	124.0	51.5	176	
12		152	39.5	192	145	43.3	188	137	47.3	184	128.7	51.8	181	
13		157	39.8	197	150	43.6	193	142	47.7	190	133.4	52.1	186	
14		163	40.2	203	155	43.9	199	147	48.0	195	138.3	52.4	191	
15		168	40.5	208	160	44.3	205	152	48.3	200	143.3	52.8	196	
145		4	129	42.4	172	123	46.7	170	116	51.4	167	107.9	56.7	165
		5	134	42.7	176	127	46.9	174	120	51.7	172	112.3	57.0	169
		6	138	43.0	181	132	47.2	179	124	52.0	176	116.8	57.3	174
	7	143	43.3	187	136	47.5	184	129	52.2	181	121.2	57.6	179	
	8	148	43.5	191	141	47.8	189	133	52.5	186	125.4	57.9	183	
	9	152	43.8	196	146	48.1	194	138	52.9	191	129.8	58.2	188	
	10	157	44.1	201	150	48.4	199	143	53.2	196	134.5	58.5	193	
	11	162	44.4	206	155	48.7	204	148	53.5	201	139.3	58.8	198	
	12	167	44.7	211	160	49.0	209	152	53.8	206	144.2	59.1	203	
	13	172	45.0	217	165	49.3	214	157	54.1	211	148.8	59.4	208	
	14	177	45.3	222	169	49.6	219	162	54.4	216	153.5	59.7	213	
	15	182	45.6	227	174	49.9	224	167	54.7	221	158.3	60.1	218	
	165	4	148	48.7	197	141	53.7	195	133	59.2	192	124.0	65.1	189
		5	153	49.1	202	146	54.0	200	138	59.5	197	128.9	65.4	194
		6	159	49.4	208	151	54.4	205	143	59.8	203	134.0	65.7	200
7		164	49.7	214	156	54.7	211	147	60.1	208	139.1	66.1	205	
8		170	50.1	220	162	55.1	217	153	60.5	213	143.8	66.4	210	
9		175	50.4	226	167	55.4	223	158	60.8	219	148.6	66.7	215	
10		181	50.8	232	173	55.8	228	164	61.2	225	154.1	67.1	221	
11		186	51.1	238	178	56.1	234	169	61.6	231	159.7	67.5	227	
12		192	51.5	244	184	56.5	240	175	62.0	237	165.3	67.9	233	
13		198	51.9	250	190	56.9	247	181	62.3	243	170.9	68.3	239	
14		204	52.3	256	196	57.3	253	186	62.7	249	176.6	68.6	245	
15		210	52.6	263	201	57.6	259	192	63.1	255	182.2	69.0	251	
195		4	173	54.2	227	164	59.9	224	153	66.4	219	138.4	74.1	213
		5	179	54.6	234	170	60.2	230	159	66.8	226	144.2	74.5	219
		6	185	54.9	240	176	60.6	236	165	67.2	232	150.1	74.8	225
	7	192	55.3	247	182	61.0	243	170	67.5	238	156.1	75.2	231	
	8	198	55.7	254	188	61.4	250	176	67.9	244	162.2	75.6	238	
	9	204	56.1	260	195	61.7	256	182	68.3	251	168.0	76.0	244	
	10	211	56.4	267	201	62.1	263	189	68.7	257	173.8	76.3	250	
	11	217	56.8	274	207	62.5	270	195	69.1	264	179.9	76.7	257	
	12	224	57.2	281	213	62.9	276	201	69.5	271	186.3	77.1	263	
	13	230	57.6	288	220	63.3	283	208	69.9	278	192.7	77.6	270	
	14	237	58.0	295	227	63.7	290	214	70.3	284	199.1	78.0	277	
	15	244	58.4	302	233	64.1	297	221	70.7	291	205.5	78.4	284	
	235	4	215	64.2	279	204	71.2	275	192	78.9	271	179.6	87.5	267
		5	222	64.5	287	211	71.5	283	199	79.2	278	186.7	87.8	275
		6	229	64.8	294	219	71.8	291	207	79.5	286	193.9	88.0	282
7		237	65.2	302	226	72.1	298	215	79.8	294	201.4	88.3	290	
8		245	65.6	311	233	72.5	305	222	80.1	302	209.0	88.6	298	
9		254	66.0	320	241	72.9	314	229	80.5	309	216.7	88.9	306	
10		263	66.4	329	250	73.3	323	236	80.8	317	223.8	89.2	313	
11		272	66.8	339	259	73.7	333	245	81.2	326	230.8	89.5	320	
12		280	67.2	347	268	74.1	342	254	81.6	335	238.9	89.9	329	
13		287	67.6	355	276	74.5	350	263	82.1	345	247.5	90.3	338	
14		295	67.9	363	284	74.9	359	271	82.5	354	256.3	90.7	347	
15		303	68.3	372	292	75.3	367	279	82.9	362	265.4	91.1	357	

NOTES

Cc (cooling capacity) - Pi (unit power input) -Hc (heat rejection) - ELWT (Evaporator leaving water temperature - Δt 5°C)
 Data refers to 0,0176m² °C/kW evaporator fouling factor

CAPCOOL_1-2-3-4-5-6_Rev.00_2

6 Capacity tables

6 - 1 Cooling Capacity Tables

EWLD265~390J-SS

Unit	EWLT (°C)	Saturated discharge temperature °C												
		25			30			35			40			
		Cc (kW)	Pi (kW)	Hc (kW)	Cc (kW)	Pi (kW)	Hc (kW)	Cc (kW)	Pi (kW)	Hc (kW)	Cc (kW)	Pi (kW)	Hc (kW)	
265	4	281	52.2	334	272	56.3	329	262	60.9	323	250	66.3	316	
	5	289	52.9	342	280	57.0	337	271	61.7	333	259	67.0	326	
	6	298	53.7	351	288	57.7	346	279	62.4	341	268	67.8	336	
	7	306	54.5	360	297	58.4	355	287	63.1	350	276	68.4	345	
	8	314	55.3	369	305	59.2	364	295	63.8	359	284	69.1	354	
	9	323	56.1	379	313	60.0	373	303	64.5	368	293	69.8	362	
	10	331	56.9	388	322	60.8	382	311	65.3	377	301	70.5	371	
	11	340	57.8	398	330	61.6	392	320	66.1	386	309	71.2	380	
	12	349	58.7	408	339	62.5	401	328	66.9	395	317	72.0	389	
	13	358	59.6	417	348	63.3	411	337	67.7	405	326	72.8	399	
	14	367	60.5	427	357	64.2	421	346	68.5	414	335	73.6	408	
	15	376	61.5	438	366	65.1	431	355	69.4	424	343	74.4	418	
	290	4	303	56.8	360	294	63.2	357	283	70.0	353	271	77.0	348
		5	313	57.2	370	303	63.8	366	292	70.4	362	280	77.6	358
		6	322	57.8	380	312	64.2	376	301	71.0	372	290	78.2	368
7		332	58.4	390	321	64.8	386	310	71.6	382	299	78.8	378	
8		341	58.8	400	331	65.4	396	320	72.0	392	308	79.2	387	
9		351	59.4	411	341	66.0	407	329	72.6	402	317	79.8	397	
10		361	60.0	421	350	66.4	417	339	73.2	412	327	80.4	407	
11		371	60.6	432	360	67.0	427	349	73.8	423	337	81.0	418	
12		382	61.2	443	371	67.6	438	359	74.4	433	346	81.6	428	
13		392	61.8	454	381	68.2	449	369	75.0	444	356	82.2	439	
14		403	62.4	465	391	68.8	460	379	75.6	455	367	82.8	449	
15		414	63.0	477	402	69.4	472	390	76.2	466	377	83.4	460	
310		4	326	61.1	387	315	67.8	383	303	75.0	378	291	82.7	373
		5	336	61.6	398	325	68.4	394	314	75.5	389	301	83.3	384
		6	346	62.2	409	335	68.9	404	324	76.2	400	311	83.9	395
	7	357	62.8	420	346	69.5	415	334	76.8	411	321	84.6	406	
	8	368	63.4	431	356	70.2	426	344	77.3	421	331	85.1	416	
	9	379	64.0	443	367	70.8	438	354	78.0	432	341	85.8	427	
	10	390	64.6	454	378	71.4	449	365	78.6	444	352	86.4	438	
	11	401	65.3	466	389	72.0	461	376	79.3	455	363	87.1	450	
	12	412	65.9	478	400	72.7	473	387	79.9	467	373	87.7	461	
	13	424	66.6	490	411	73.3	485	398	80.6	479	384	88.4	473	
	14	436	67.3	503	423	74.0	497	410	81.3	491	396	89.1	485	
	15	448	68.0	516	435	74.7	509	421	81.9	503	407	89.7	497	
	330	4	349	65.4	414	337	72.4	409	324	80.0	404	310	88.4	399
		5	360	66.0	426	348	73.0	421	335	80.6	416	321	89.0	410
		6	371	66.6	437	359	73.6	432	346	81.4	427	332	89.6	422
7		382	67.2	449	370	74.2	444	357	82.0	439	343	90.4	434	
8		394	68.0	462	381	75.0	456	368	82.6	451	354	91.0	445	
9		406	68.6	474	393	75.6	469	380	83.4	463	365	91.8	457	
10		418	69.2	487	405	76.4	481	391	84.0	475	377	92.4	469	
11		430	70.0	500	417	77.0	494	403	84.8	488	388	93.2	482	
12		443	70.6	513	429	77.8	507	415	85.4	500	400	93.8	494	
13		455	71.4	527	442	78.4	520	427	86.2	513	412	94.6	507	
14		468	72.2	540	454	79.2	533	440	87.0	527	424	95.4	520	
15		481	73.0	554	467	80.0	547	452	87.6	540	437	96.0	533	
360		4	380	68.6	448	365	76.5	442	351	84.7	436	336	93.4	430
		5	391	69.2	461	377	77.1	454	363	85.3	448	348	94.1	442
		6	403	69.8	473	389	77.8	467	375	86.1	461	360	94.7	455
	7	415	70.5	486	401	78.4	479	386	86.7	473	372	95.5	467	
	8	428	71.2	499	413	79.2	492	398	87.4	486	384	96.2	480	
	9	440	71.9	512	425	79.8	505	411	88.1	499	395	96.9	492	
	10	453	72.6	526	438	80.6	518	423	88.8	512	408	97.6	505	
	11	466	73.3	539	451	81.3	532	436	89.6	525	420	98.4	518	
	12	479	74.0	553	464	82.1	546	448	90.3	539	433	99.1	532	
	13	493	74.8	568	477	82.8	560	461	91.1	552	445	99.9	545	
	14	507	75.6	582	490	83.5	574	475	91.9	566	458	101	559	
	15	520	76.4	597	504	84.3	588	488	92.6	581	472	101	573	
	390	4	411	71.8	483	394	80.6	474	378	89.4	467	362	98.4	461
		5	423	72.4	496	406	81.2	487	391	90.0	481	375	99.2	474
		6	436	73.0	509	419	82.0	501	403	90.8	494	388	99.8	488
7		449	73.8	522	431	82.6	514	416	91.4	507	400	101	501	
8		462	74.4	536	444	83.4	528	428	92.2	521	413	101	514	
9		475	75.2	550	457	84.0	541	441	92.8	534	425	102	527	
10		489	76.0	565	471	84.8	556	455	93.6	548	438	103	541	
11		502	76.6	579	484	85.6	570	468	94.4	562	452	104	555	
12		516	77.4	594	498	86.4	585	482	95.2	577	465	104	569	
13		530	78.2	609	512	87.2	599	495	96.0	591	478	105	584	
14		545	79.0	624	527	87.8	614	509	96.8	606	492	106	598	
15		560	79.8	639	541	88.6	630	524	97.6	621	506	107	613	

NOTES

Cc (cooling capacity) - Pi (unit power input) - Hc (heat rejection) - ELWT (Evaporator leaving water temperature - Δt 5°C)
 Data refers to 0,0176m² °C/kW evaporator fouling factor

CAPCOOL_1-2-3-4-5-6_Rev.00_3

6 Capacity tables

6 - 1 Cooling Capacity Tables

EWLD265~390J-SS

Unit	EWLT (°C)	Saturated discharge temperature °C												
		45			50			55			60			
		Cc (kW)	Pi (kW)	Hc (kW)	Cc (kW)	Pi (kW)	Hc (kW)	Cc (kW)	Pi (kW)	Hc (kW)	Cc (kW)	Pi (kW)	Hc (kW)	
265	4	238	72.4	310	226	79.4	306	215	87.3	302	201	96.0	297	
	5	247	73.0	320	234	79.9	314	222	87.8	310	209	96.4	305	
	6	256	73.7	329	242	80.5	323	229	88.2	317	217	96.9	314	
	7	265	74.5	339	251	81.2	332	237	88.8	326	224	97.4	322	
	8	274	75.2	349	260	81.9	342	246	89.4	335	231	97.9	329	
	9	281	75.8	357	270	82.6	352	255	90.1	345	240	98.4	338	
	10	289	76.5	366	278	83.2	361	264	90.7	355	249	99.1	348	
	11	298	77.2	375	286	83.9	370	273	91.4	364	258	99.7	357	
	12	306	77.9	384	294	84.5	378	281	92.0	373	267	100	367	
	13	314	78.6	393	302	85.2	387	289	92.7	382	275	101	376	
	14	323	79.3	402	310	85.9	396	297	93.3	390	283	102	385	
	15	331	80.1	411	319	86.6	405	305	94.0	399	291	102	394	
	290	4	258	84.8	343	246	93.4	339	232	103	334	216	113	329
		5	267	85.4	353	254	93.8	348	240	103	344	225	114	339
		6	277	86.0	363	263	94.4	357	249	104	353	234	115	348
7		286	86.6	373	272	95.0	367	257	104	362	242	115	358	
8		296	87.0	383	282	95.6	377	267	105	372	251	116	367	
9		305	87.6	392	291	96.2	387	276	106	382	260	116	376	
10		314	88.2	402	300	96.8	397	286	106	392	269	117	386	
11		324	88.8	412	310	97.4	407	295	107	402	279	118	396	
12		333	89.4	423	319	98.0	417	304	108	412	288	118	407	
13		343	90.0	433	329	98.6	428	314	108	422	298	119	416	
14		353	90.6	444	339	99.2	438	323	109	432	307	119	426	
15		363	91.2	454	349	99.8	448	333	109	443	317	120	437	
310		4	277	91.1	368	264	100	364	249	111	359	232	122	354
		5	287	91.8	379	273	101	374	258	111	369	241	122	364
		6	297	92.4	389	282	102	384	267	112	379	251	123	374
	7	307	93.0	400	292	102	394	276	112	388	260	124	384	
	8	318	93.6	411	302	103	405	286	113	399	269	124	394	
	9	328	94.2	422	313	104	416	296	114	410	278	125	403	
	10	338	94.9	433	323	104	427	307	114	421	289	126	414	
	11	348	95.5	444	333	105	438	317	115	432	299	126	425	
	12	359	96.2	455	344	106	449	327	116	443	310	127	437	
	13	370	96.9	467	354	106	460	338	116	454	320	128	447	
	14	381	97.6	478	365	107	472	348	117	465	330	128	458	
	15	392	98.2	490	376	108	483	359	118	477	341	129	470	
	330	4	296	97.4	393	282	107	389	266	118	384	248	130	378
		5	306	98.2	405	291	108	399	276	119	395	258	131	389
		6	317	98.8	416	301	109	410	285	120	405	268	131	399
7		328	99.4	428	312	109	421	295	120	415	278	132	410	
8		339	100	440	323	110	433	305	121	426	288	133	420	
9		350	101	451	334	111	445	316	122	438	297	133	431	
10		362	102	463	345	112	457	328	122	450	308	134	442	
11		373	102	475	356	112	469	339	123	462	319	135	454	
12		384	103	487	368	113	481	350	124	474	331	136	466	
13		396	104	500	379	114	493	361	125	486	342	137	478	
14		408	105	513	391	115	506	373	125	498	353	137	490	
15		420	105	525	403	115	518	384	126	510	364	138	502	
360		4	321	103	424	305	114	419	286	126	411	262	139	402
		5	332	104	436	316	114	430	297	126	423	273	140	413
		6	344	104	448	326	115	441	307	127	434	284	141	425
	7	356	105	461	338	116	454	318	128	445	295	141	437	
	8	368	106	474	350	117	466	329	128	457	306	142	448	
	9	380	107	486	362	117	479	341	129	470	317	143	459	
	10	391	107	499	373	118	491	353	130	482	328	143	471	
	11	403	108	511	385	119	504	365	131	495	340	144	484	
	12	416	109	525	397	119	517	378	132	508	352	145	497	
	13	428	110	538	410	120	530	388	132	521	364	146	510	
	14	441	110	551	422	121	543	400	133	533	376	147	522	
	15	454	111	565	435	122	556	413	134	547	388	147	535	
	390	4	346	108	455	328	120	448	305	133	438	277	148	425
		5	358	109	467	340	120	460	317	134	451	288	149	437
		6	371	110	480	351	121	473	329	134	464	300	150	450
7		383	111	494	364	122	486	341	135	476	312	150	463	
8		396	111	507	376	123	499	352	136	488	324	151	476	
9		409	112	521	389	123	512	365	137	501	336	152	488	
10		421	113	534	402	124	526	377	137	515	348	153	500	
11		434	114	548	414	125	539	390	138	529	360	153	513	
12		447	114	562	427	126	553	403	139	542	373	154	527	
13		460	115	576	440	127	566	415	140	555	385	155	541	
14		474	116	590	453	127	580	428	141	569	398	156	554	
15		488	117	604	466	128	595	441	141	583	411	157	568	

NOTES

Cc (cooling capacity) - Pi (unit power input) -Hc (heat rejection) - ELWT (Evaporator leaving water temperature - Δt 5°C)
 Data refers to 0,0176m² °C/kW evaporator fouling factor

CAPCOOL_1-2-3-4-5-6_Rev.00_4

6 Capacity tables

6 - 1 Cooling Capacity Tables

EWLD430-530J-SS

Unit	EWLT (°C)	Saturated discharge temperature °C												
		25			30			35			40			
		Cc (kW)	Pi (kW)	Hc (kW)	Cc (kW)	Pi (kW)	Hc (kW)	Cc (kW)	Pi (kW)	Hc (kW)	Cc (kW)	Pi (kW)	Hc (kW)	
430	4	460	77.8	537	441	87.1	528	423	96.8	520	406	107	513	
	5	475	78.4	553	456	87.8	544	438	97.4	535	419	108	527	
	6	490	79.0	569	471	88.5	560	453	98.2	551	434	108	542	
	7	504	79.6	584	487	89.1	576	468	98.9	567	449	109	558	
	8	518	80.2	598	501	89.8	590	483	99.7	583	464	110	574	
	9	533	80.8	614	515	90.4	605	498	100	598	479	111	590	
	10	548	81.4	629	530	91.1	621	512	101	613	494	112	605	
	11	563	82.0	645	545	91.8	636	527	102	628	508	112	620	
	12	578	82.6	661	560	92.4	652	541	102	644	523	113	636	
	13	594	83.2	677	575	93.1	668	556	103	660	538	114	651	
	14	610	83.8	693	591	93.7	684	572	104	676	553	115	667	
	15	625	84.4	710	606	94.3	701	587	105	692	568	115	683	
	470	4	508	83.8	592	488	93.6	582	468	104	572	450	116	565
		5	526	84.4	611	506	94.4	600	485	105	590	463	116	580
		6	544	85.0	629	524	95.0	619	502	106	608	480	117	597
7		559	85.4	645	542	95.6	637	520	106	626	497	118	615	
8		575	86.0	661	557	96.2	653	538	107	645	515	119	633	
9		591	86.4	677	573	96.8	669	554	108	661	533	119	652	
10		607	86.8	694	589	97.4	686	569	108	678	549	120	669	
11		623	87.4	711	605	98.0	703	585	109	694	565	121	686	
12		640	87.8	728	621	98.4	719	601	110	711	581	122	702	
13		657	88.2	745	638	99.0	737	617	110	728	597	122	719	
14		674	88.6	763	654	99.6	754	634	111	745	613	123	736	
15		691	89.0	780	671	100	771	651	112	762	629	124	753	
500		4	536	94.1	630	517	103	620	496	113	609	475	124	599
		5	553	95.1	648	533	104	637	513	114	627	491	125	616
		6	569	96.2	666	550	105	655	530	115	645	508	126	635
	7	585	97.2	683	567	106	674	547	116	663	525	127	652	
	8	602	98.3	700	583	107	691	564	117	681	542	128	670	
	9	618	99.3	717	599	108	708	580	118	698	559	130	688	
	10	635	100	735	616	110	725	596	120	716	575	131	706	
	11	652	102	753	632	111	743	612	121	733	591	132	723	
	12	669	103	771	649	112	761	629	122	751	608	133	741	
	13	686	104	790	667	113	779	646	123	769	624	134	758	
	14	704	105	809	684	114	798	663	124	787	641	135	776	
	15	722	106	828	701	115	817	680	125	805	658	136	794	
	530	4	563	104	667	545	113	657	523	122	645	500	133	633
		5	579	106	685	561	114	675	542	123	665	518	134	652
		6	595	107	702	577	115	692	557	125	682	537	136	672
7		612	109	721	593	117	710	573	126	700	553	137	690	
8		628	111	739	609	118	728	590	128	717	569	138	707	
9		645	112	757	626	120	746	606	129	735	585	140	725	
10		662	114	776	643	122	765	623	131	753	601	141	742	
11		680	116	796	660	123	783	640	132	772	618	142	760	
12		698	117	815	678	125	803	657	134	791	635	144	779	
13		716	119	835	695	127	822	674	135	809	652	146	797	
14		734	121	855	713	128	842	692	137	829	669	147	816	
15		752	123	875	731	130	862	710	139	848	687	149	835	

NOTES

Cc (cooling capacity) - Pi (unit power input) -Hc (heat rejection) - ELWT (Evaporator leaving water temperature - Δt 5°C)
 Data refers to 0,0176m² °C/kW evaporator fouling factor

6 Capacity tables

6 - 1 Cooling Capacity Tables

EWLD430~530J-SS

Unit	EWLT (°C)	Saturated discharge temperature °C												
		45			50			55			60			
		Cc (kW)	Pi (kW)	Hc (kW)	Cc (kW)	Pi (kW)	Hc (kW)	Cc (kW)	Pi (kW)	Hc (kW)	Cc (kW)	Pi (kW)	Hc (kW)	
430	4	388	118	507	368	131	499	345	145	490	318	162	480	
	5	401	119	520	381	132	513	358	146	504	331	162	493	
	6	414	120	534	395	132	527	371	147	518	344	163	507	
	7	429	121	549	408	133	541	385	147	532	358	164	521	
	8	443	121	565	421	134	555	398	148	546	371	164	535	
	9	458	122	581	436	135	570	411	149	560	385	165	550	
	10	474	123	596	451	135	586	425	150	575	398	166	563	
	11	489	124	612	466	136	602	440	150	590	411	166	577	
	12	503	124	628	481	137	618	455	151	606	425	167	592	
	13	518	125	643	496	138	634	470	152	622	440	168	608	
	14	532	126	658	510	139	649	486	153	638	455	169	624	
	15	547	127	674	525	139	664	500	154	654	471	170	640	
	470	4	430	128	558	407	142	550	384	158	542	359	175	534
		5	444	129	573	422	143	565	398	158	557	373	176	549
		6	458	130	588	438	144	582	414	159	573	388	176	564
7		474	130	604	452	144	596	429	160	589	403	177	579	
8		491	131	622	466	145	611	444	160	604	418	177	595	
9		508	132	640	483	146	628	457	161	618	433	178	611	
10		526	133	659	500	147	647	473	162	634	448	178	626	
11		544	134	677	518	147	665	490	162	652	462	179	641	
12		559	134	693	536	148	684	507	163	671	478	180	658	
13		575	135	710	552	149	701	525	164	689	495	181	676	
14		591	136	726	567	150	717	543	165	708	513	181	694	
15		607	137	743	583	151	734	558	166	724	531	182	713	
500		4	453	137	589	430	151	581	406	166	573	381	184	564
		5	469	138	606	445	151	596	421	167	588	396	184	580
		6	485	139	623	461	152	614	436	168	604	411	185	596
	7	502	140	641	477	153	630	452	169	620	426	186	611	
	8	519	141	660	493	154	648	468	170	637	440	187	627	
	9	536	142	677	511	156	667	484	171	654	456	187	644	
	10	552	143	695	528	157	684	501	172	672	472	188	661	
	11	569	144	713	544	158	702	518	173	691	488	189	678	
	12	585	145	730	562	159	720	535	174	708	506	190	696	
	13	602	146	748	578	160	737	552	175	726	523	191	714	
	14	618	147	765	594	161	755	569	176	744	540	192	732	
	15	635	148	783	610	162	772	585	177	761	557	193	750	
	530	4	476	145	620	453	159	611	429	175	604	402	192	594
		5	493	146	639	467	160	627	444	176	620	418	193	610
		6	511	147	659	485	161	646	458	176	635	434	194	627
7		530	149	679	502	162	665	474	178	652	448	195	643	
8		547	150	697	521	164	685	492	179	671	462	196	658	
9		563	152	714	539	165	705	510	180	690	479	197	676	
10		579	153	732	555	166	722	528	181	710	497	198	695	
11		595	154	749	571	168	739	546	183	729	515	199	715	
12		612	156	767	587	169	756	562	184	746	534	201	735	
13		628	157	786	604	170	774	578	185	763	551	202	753	
14		645	159	804	620	172	792	594	187	781	567	203	770	
15		663	160	823	637	173	810	611	188	799	583	205	787	

NOTES

Cc (cooling capacity) - Pi (unit power input) - Hc (heat rejection) - ELWT (Evaporator leaving water temperature - Δt 5°C)
 Data refers to 0,0176m² °C/kW evaporator fouling factor

CAPCOOL_1-2-3-4-5-6_Rev.00_6

7 Pressure drops

7 - 1 Evaporator Pressure Drops

7

Evaporator Pressure Drops

EWLD-J-SS

	110	130	145	165	195	235	265	290	310	330
Cooling capacity (kW)	110	128	143	164	192	237	265	286	307	328
Water flow (l/s) - Evaporator	5.24	6.10	6.84	7.84	9.16	11.32	12.65	13.68	14.68	15.69
Evaporator Pressure Drops (kPa)	14	12	36	34	32	25	31	36	36	34

NOTES

Water flow and pressure drop referred to nominal condition: evaporator water in/out: 12/7°C - saturated discharge temperature 45°C

	360	390	430	470	500	530
Cooling capacity (kW)	356	383	429	474	502	530
Water flow (l/s) - Evaporator	17.00	18.32	20.47	22.63	23.97	25.30
Evaporator Pressure Drops (kPa)	34	32	32	25	25	31

NOTES

Water flow and pressure drop referred to nominal condition: evaporator water in/out: 12/7°C - saturated discharge temperature 45°C

Evaporator Pressure Drops

To determinate the evaporator pressure drop for different versions or at different working condition, please refer to te following formula:

$$PD_2 \text{ (kPa)} = PD_1 \text{ (kPa)} \times \left(\frac{Q_2 \text{ (l/s)}}{Q_1 \text{ (l/s)}} \right)^{1.8}$$

where:

PD₂	Pressure drop to be determinated (kPa)
PD₁	Pressure drop at nominal condition (kPa)
Q₂	water flow at new working condition (l/s)
Q₁	water flow at nominal condition (l/s)

How to use the fomula: Example (Evaporator)

The unit EWLD110J-SS at nominal working conditions has the following data:

- evaporator water in/out: 11/6°C

- condenser water in/out: 35°C

The cooling capacity at these working conditions is: 137 kW

The evaporator water flow at these working conditions is: 6.55 l/s

The unit EWLD110J-SS at nominal working conditions has the following data:

- evaporator water in/out: 12/7°C

- Saturated discharge temperature: 45°C

The cooling capacity at these working conditions is: 110 kW

The evaporator water flow at these working conditions is: 5.24 l/s

The evaporator pressure drop at these working conditions is: 14 kPa

The evaporator pressure drop at the selected working condition will be:

$$PD_2 \text{ (kPa)} = 14 \text{ (kPa)} \times \left(\frac{6.55 \text{ (l/s)}}{5.24 \text{ (l/s)}} \right)^{1.8}$$

$$PD_2 \text{ (kPa)} = 21 \text{ (kPa)}$$

Note: If the calculated evaporator water pressure drop is below 10 kPa or above 100 kPa please contact the factory for dedicated evaporator.

EPD_1_Rev.00_1

8 Dimensional drawings

8 - 1 Dimensional Drawings

EWLD-J-SS / 1 circuit

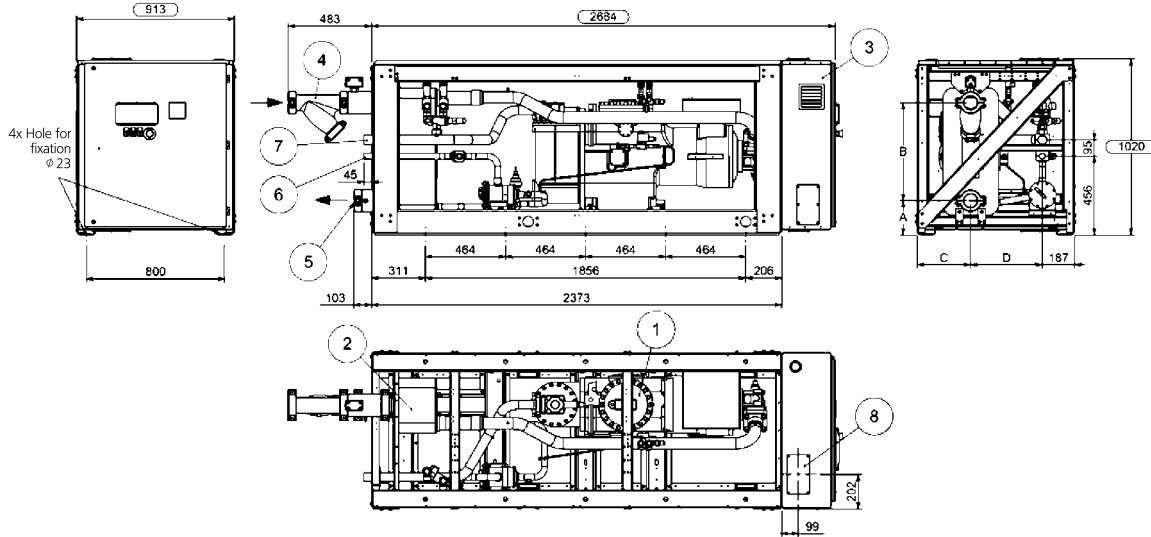

Models	Dimensions (mm)			
	A	B	C	D
EWLD-J-SS				
110	198	519	326	398
130	198	519	326	398
145	198	568	311	413
165	198	568	311	413
195	198	568	311	413
235	198	568	311	413
265	198	568	311	413

Legend

- 1 Compressor
- 2 Evaporator
- 3 Electrical panel
- 4 Evaporator water inlet
- 5 Evaporator water outlet
- 6 Liquid line inlet connection
- 7 Gas discharge line connection
- 8 Power connections slot

DMN_1-2_Rev.00_1

8 Dimensional drawings

8 - 1 Dimensional Drawings

EWLD-J-SS / 2 Circuits

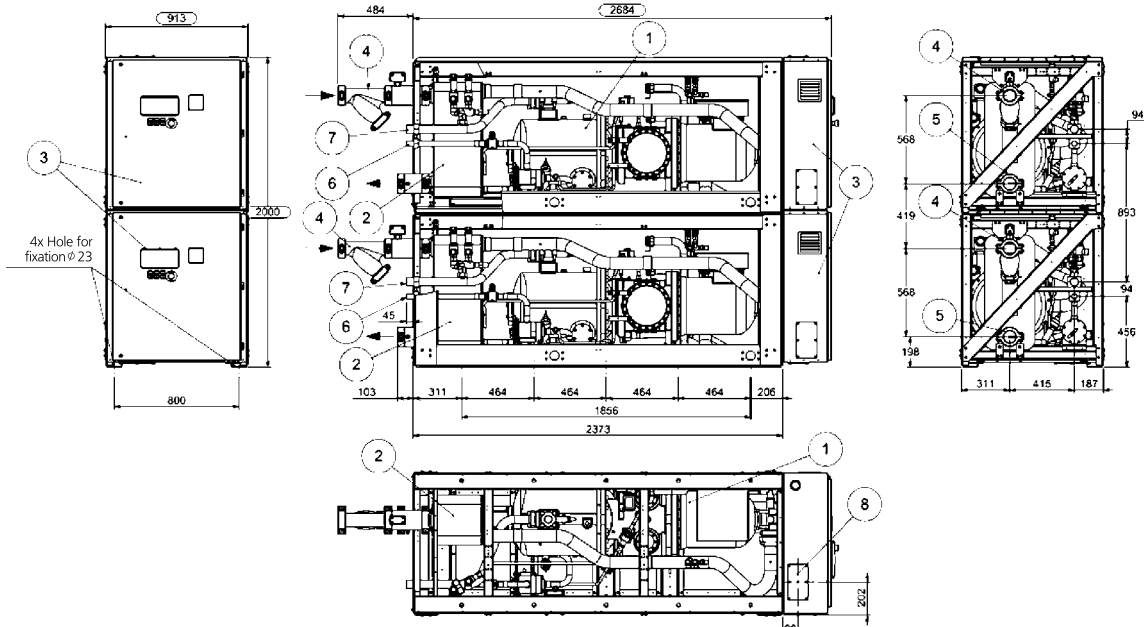

Note: Dimension refers to 2 circuit units (size from 290-530).

Legend

- 1 Compressor
- 2 Evaporator
- 3 Electrical panel
- 4 Evaporator water inlet
- 5 Evaporator water outlet
- 6 Liquid line inlet connection
- 7 Gas discharge line connection
- 8 Power connections slot

DMN_1-2_Rev.00_2

9 Sound data

9 - 1 Sound Level Data

Sound levels

EWLD-J-SS

Unit size	Sound pressure level at 1 m from the unit in semispheric free field (rif. 2×10^{-5} Pa)									power	
	63 Hz	125 Hz	250 Hz	500 Hz	1000 Hz	2000 Hz	4000 Hz	8000 Hz	dB(A)	dB(A)	
110	57.0	61.5	66.5	70.9	66.0	63.6	51.0	48.1	71.4	88.6	
130	57.0	61.5	66.5	70.9	66.0	63.6	51.0	48.1	71.4	88.6	
145	57.0	61.5	66.5	70.9	66.0	63.6	51.0	48.1	71.4	88.6	
165	57.0	61.5	66.5	70.9	66.0	63.6	51.0	48.1	71.4	88.6	
195	57.0	61.5	66.5	70.9	66.0	63.6	51.0	48.1	71.4	88.6	
235	58.3	58.3	63.8	68.8	63.3	64.3	53.3	49.8	70.0	87.2	
265	58.3	58.3	63.8	68.8	63.3	64.3	53.3	49.8	70.0	87.2	
290	60.0	64.5	69.5	73.9	69.0	66.6	54.0	51.1	74.4	92.4	
310	60.0	64.5	69.5	73.9	69.0	66.6	54.0	51.1	74.4	92.4	
330	60.0	64.5	69.5	73.9	69.0	66.6	54.0	51.1	74.4	92.4	
360	60.0	64.5	69.5	73.9	69.0	66.6	54.0	51.1	74.4	92.4	
390	60.0	64.5	69.5	73.9	69.0	66.6	54.0	51.1	74.4	92.4	
430	60.7	63.2	68.4	73.0	67.9	67.0	55.3	52.0	73.8	91.8	
470	61.3	61.3	66.8	71.8	66.3	67.3	56.3	52.8	73.0	91.0	
500	61.3	61.3	66.8	71.8	66.3	67.3	56.3	52.8	73.0	91.0	
530	61.3	61.3	66.8	71.8	66.3	67.3	56.3	52.8	73.0	91.0	

NOTES

- 1 The values are according to ISO 3744 and are referred to: evaporator 12/7° C, saturated discharge temperature 45° C, full load operation.
- 2 The above sound pressure levels will decrease by 4dB(A) when a compressor sound enclosure (option) is installed.

Sound pressure level correction factor for different distances

Unit size	Distance					
	1 m	5 m	10 m	15 m	20 m	25 m
110	0.0	-7.9	-12.7	-15.8	-18.1	-19.8
130	0.0	-7.9	-12.7	-15.8	-18.1	-19.8
145	0.0	-7.9	-12.7	-15.8	-18.1	-19.8
165	0.0	-7.9	-12.7	-15.8	-18.1	-19.8
195	0.0	-7.9	-12.7	-15.8	-18.1	-19.8
235	0.0	-7.5	-12.2	-15.3	-17.5	-19.3
265	0.0	-7.9	-12.7	-15.8	-18.1	-19.8
290	0.0	-7.5	-12.2	-15.3	-17.5	-19.3
310	0.0	-7.5	-12.2	-15.3	-17.5	-19.3
330	0.0	-7.9	-12.7	-15.8	-18.1	-19.8
360	0.0	-7.5	-12.2	-15.3	-17.5	-19.3
390	0.0	-7.5	-12.2	-15.3	-17.5	-19.3
430	0.0	-7.5	-12.2	-15.3	-17.5	-19.3
470	0.0	-7.5	-12.2	-15.3	-17.5	-19.3
500	0.0	-7.5	-12.2	-15.3	-17.5	-19.3
530	0.0	-7.5	-12.2	-15.3	-17.5	-19.3

NOTES

- 1 The values are dB(A) (pressure level).

NSL_1_Rev.00_1

10 Installation

10 - 1 Installation Method

10

Installation notes

Warning

Installation and maintenance are to be performed only by qualified personnel who are familiar with local codes and regulations, and who are experienced with this type of equipment. Must be avoided the unit installation in places that could be considered dangerous for all the maintenance operations.

Handling

The chiller is mounted on heavy wooden skids to protect the unit from accidental damage and to permit easy handling and moving. It is recommended that all moving and handling be performed with the skids under the unit when possible and that the skids not be removed until the unit is in the final location.

If the unit must be hoisted, it is necessary to lift the unit by attaching cables or chains at the lifting holes in the evaporator tube sheets. Spreader bars must be used to protect the control cabinet and the other areas of the chiller.

Location

A levelled and sufficiently strong floor is required. If necessary, additional structural members should be provided to transfer the weight of the unit to the nearest beams.

Rubber-in-shear isolators are furnished and field placed under each corner of the package. A rubber anti-skid pad should be used under isolators if hold-down bolts are not used. Vibration isolator in all water piping connected to the chiller are recommended to avoid straining the piping and transmitting vibration and noise.

Minimum space requirements

Every side of the machine must be accessible for all post-installation maintenance activities. The minimum space required is shown on the following drawing

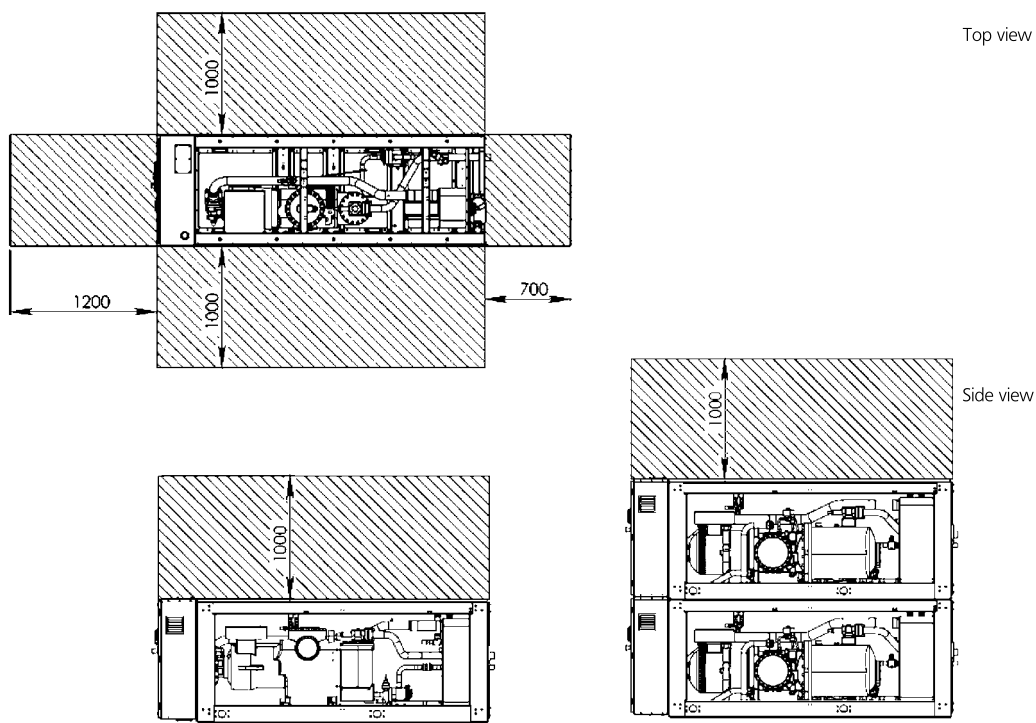

Minimum clearance requirements for machine maintenance

INN_1_Rev.00_1

10 Installation

10 - 2 Water Charge, Flow and Quality

Water charge, flow and quality

ITEMS ⁽¹⁾ (5)		Cooling water			Cooled water		Heated water ⁽²⁾				Tendency if out of criteria		
		Circulating system		Once flow	Circulating water (Below 20°C)	Supply water ⁽⁴⁾	Low temperature		High temperature				
		Circulating water	Supply water ⁽⁴⁾	Flowing water			Circulating water (20°C - 60°C)	Supply water ⁽⁴⁾	Circulating water (80°C - 90°C)	Supply water ⁽⁴⁾			
Items to be controlled:	pH	at 25°C	6.5 - 8.2	6.0 - 8.0	6.0 - 8.0	6.8 - 8.0	6.0 - 8.0	7.0 - 8.0	7.0 - 8.0	7.0 - 8.0	7.0 - 8.0	Corrosion+Scale	
	Electrical conductivity	[mS/m] at 25°C	Below 80	Below 30	Below 40	Below 80	Below 80	Below 30	Below 30	Below 30	Below 30	Below 30	Corrosion+Scale
		[µS/cm] at 25°C	(Below 800)	(Below 300)	(Below 400)	(Below 800)	(Below 800)	(Below 300)	(Below 300)	(Below 300)	(Below 300)	(Below 300)	Corrosion+Scale
	Chloride ion	[mgCl ⁻² /l]	Below 200	Below 50	Below 50	Below 200	Below 50	Below 50	Below 50	Below 50	Below 30	Below 30	Corrosion
	Sulfate ion	[mgSO ²⁻ ₄ /l]	Below 200	Below 50	Below 50	Below 200	Below 50	Below 50	Below 50	Below 50	Below 30	Below 30	Corrosion
	Alkalinity (pH4.8)	[mgCaCO ₃ /l]	Below 100	Below 50	Below 50	Below 100	Below 50	Below 50	Below 50	Below 50	Below 50	Below 50	Scale
	Total hardness	[mgCaCO ₃ /l]	Below 200	Below 70	Below 70	Below 200	Below 70	Below 70	Below 70	Below 70	Below 70	Below 70	Scale
	Calcium hardness	[mgCaCO ₃ /l]	Below 150	Below 50	Below 50	Below 50	Below 50	Below 50	Below 50	Below 50	Below 50	Below 50	Scale
	Silica ion	[mgSiO ₂ /l]	Below 50	Below 30	Below 30	Below 30	Below 30	Below 30	Below 30	Below 30	Below 30	Below 30	Scale
	Oxygen	[mgO ₂ /l]	Below 1.0	Below 1.0	Below 1.0	Below 1.0	Below 1.0	Below 1.0	Below 1.0	Below 1.0	Below 1.0	Below 1.0	Corrosion
	Particle size	(mm)	Below 0.5	Below 0.5	Below 0.5	Below 0.5	Below 0.6	Below 0.5	Below 0.6	Below 0.5	Below 0.6	Below 0.6	Erosion
	Total dissolved solids	(mg/l)	Below 1000	Below 1000	Below 1000	Below 1000	Below 1001	Below 1000	Below 1001	Below 1000	Below 1001	Below 1001	Erosion
	Ethylene Glycol (weight conc.)		Below 60%	Below 60%	Below ---	Below 60%	Below 60%	Below 60%	Below 60%	Below 60%	Below 60%	Below 60%	---
Items to be referred to:	Nitrate ion	(mg NO ₃ -l)	Below 100	Below 100	Below 100	Below 100	Below 101	Below 100	Below 101	Below 100	Below 101	Below 101	Corrosion
	TOC, Total organic carbon	(mg/l)	Below 1.0	Below 1.0	Below 1.0	Below 1.0	Below 1.0	Below 1.0	Below 1.0	Below 1.0	Below 1.0	Below 1.0	Scale
	Iron	(mgFe/l)	Below 1.0	Below 0.3	Below 1.0	Below 1.0	Below 0.3	Below 1.0	Below 0.3	Below 1.0	Below 0.3	Below 0.3	Corrosion+Scale
	Copper	(mgCu/l)	Below 0.3	Below 0.1	Below 1.0	Below 1.0	Below 1.0	Below 1.0	Below 0.1	Below 1.0	Below 0.1	Below 0.1	Corrosion
	Sulfite ion	[mgS ²⁻ /l]	Not detectable	Not detectable	Not detectable	Not detectable	Not detectable	Not detectable	Not detectable	Not detectable	Not detectable	Not detectable	Corrosion
	Ammonium ion	[mgNH ₄ ⁺ /l]	Below 1.0	Below 0.1	Below 1.0	Below 1.0	Below 0.1	Below 0.3	Below 0.1	Below 0.1	Below 0.1	Below 0.1	Corrosion
	Remaining chloride	[mgCl ₂ /l]	Below 0.3	Below 0.3	Below 0.3	Below 0.3	Below 0.3	Below 0.25	Below 0.3	Below 0.1	Below 0.3	Below 0.3	Corrosion
	Free carbide	[mgCO ₂ /l]	Below 4.0	Below 4.0	Below 4.0	Below 4.0	Below 4.0	Below 0.4	Below 4.0	Below 0.4	Below 4.0	Below 4.0	Corrosion
Stability index		6.0 - 7.0	---	---	---	---	---	---	---	---	---	Corrosion + Scale	

NOTES

- Names, definitions and units are according to JIS K 0101. Units and figures between brackets are old units published as reference only.
- In case of using heated water (more than 40°C), corrosion is generally noticeable. Especially when the iron material is in direct contact with water without any protection shields, it is desirable to give the valid measures for corrosion. e.g. chemical measure.
- In the cooling water using hermetic cooling tower, closed circuit water is according to heated water standard, and scattered water is according to cooling water standard.
- Supply water is considered drink water, industrial water and ground water except for genuine water, neutral water and soft water.
- The above mentioned items are representable items in corrosion and scale cases.
- The limits above have to be considered as a general prescription and can not totally assure the absence of corrosion and erosion. Some particular combinations of elements or the presence of components not listed in the table or factors not considered may trigger corrosion phenomena.

WAFLOWQA_1-2_Rev.00_1

10 Installation

10 - 2 Water Charge, Flow and Quality

10

Water content in cooling circuits

The cooled water distribution circuits should have a minimum water content to avoid excessive compressors starts and stops.

In fact, each time the compressor starts up, an excessive quantity of oil goes from the compressor's pump and simultaneously there is a rise in the temperature of the compressor motor's stator, due to the inrush current during the start-up.

To prevent damage to the compressors, it has been envisaged the application of a device to limit frequent stops and restarts.

During the span of one hour there will be no more than 6 starts of the compressor. The plant side should therefore ensure that the overall water content allows a more constant functioning of the unit and consequently greater environmental comfort. The minimum water content per unit should be calculated using this simplified formula:

For 1 compressor unit

$$M(\text{Liters}) = (0.94 \times \Delta T(^{\circ}\text{C}) + 5.87) \times P(\text{kW})$$

For 2 compressors unit

$$M(\text{Liters}) = (0.1595 \times \Delta T(^{\circ}\text{C}) + 3.0825) \times P(\text{kW})$$

where:

M minimum water content per unit expressed in litres

P Cooling Capacity of the unit expressed in kW

ΔT evaporator entering / leaving water temperature difference expressed in $^{\circ}\text{C}$

This formula is valid for:

- standard microprocessor parameters

For more accurate determination of quantity of water, it is advisable to contact the designer of the plant.

WAFLOWQUA_1-2_Rev.00_2

11 Operation range

11 - 1 Operation Range

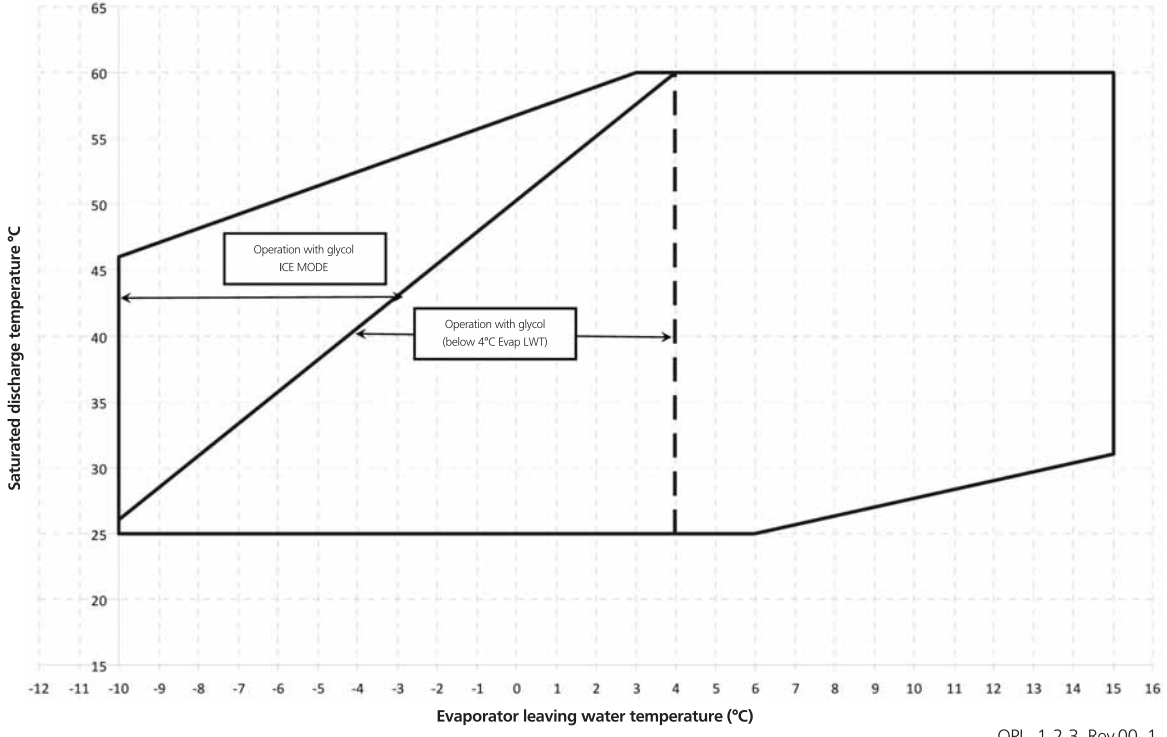

11 Operation range

11 - 1 Operation Range

11

Table 1 - Evaporator minimum and maximum water Δt

Max evaporator water ΔT	°C	8
Min evaporator water ΔT	°C	4

Table 2 - Evaporator fouling factors

Fouling factors $m^2\text{°C} / kW$	Cooling capacity correction factor	Power input correction factor	EER correction factor
0.0176	1.000	1.000	1.000
0.0440	0.978	0.986	0.992
0.0880	0.957	0.974	0.983
0.1320	0.938	0.962	0.975

Table 3.1 - Minimum glycol percentage for low water temperature

Evaporator leaving water temperature °C	2	0	-2	-4	-6	-8
Ethylene glycol (%)	10	20	20	20	30	30
Propylene glycol (%)	10	20	20	30	30	30

Note: Minimum glycol percentage to be used with evaporator leaving water temperature below 4°C to prevent freezing of water circuit.

Table 3.2 - Minimum glycol percentage for low air temperature

	Air ambient temperature (°C) (2)	-3	-8	-15	-23	-35
Ethylene glycol (%) (1)		10%	20%	30%	40%	50%
	Air ambient temperature (°C) (2)	-3	-7	-12	-20	-32
Propylene glycol (%) (1)		10%	20%	30%	40%	50%

Note (1): Minimum glycol percentage to prevent freezing of water circuit at indicated air ambient temperature

Note (2): Air ambient temperature do exceed the operating limits of the unit, as protection of water circuit may be needed in winter season at non-working conditions.

Table 4 - Correction factors for low evaporator leaving water temperature

Evaporator leaving water temperature °C	2	0	-2	-4	-6	-8
Cooling capacity	0.842	0.785	0.725	0.670	0.613	0.562
Compressor power input	0.950	0.940	0.920	0.890	0.870	0.840

Note: Correction factors have to be applied at working conditions: evaporator leaving water temperature 7°C

Table 5 - Correction factors for water and glycol mixture

	Ethylene glycol (%)	10%	20%	30%	40%	50%
Ethylene glycol	Cooling capacity	0.991	0.982	0.972	0.961	0.946
	Compressor power input	0.996	0.992	0.986	0.976	0.966
	Flow Rate (Δt)	1.013	1.04	1.074	1.121	1.178
	Evaporator Pressure Drop	1.070	1.129	1.181	1.263	1.308
Ethylene glycol	Cooling capacity	0.985	0.964	0.932	0.889	0.846
	Compressor power input	0.993	0.983	0.969	0.948	0.929
	Flow Rate (Δt)	1.017	1.032	1.056	1.092	1.139
	Evaporator Pressure Drop	1.120	1.272	1.496	1.792	2.128

OPL_1-2-3_Rev.00_2

11 Operation range

11 - 1 Operation Range

How to use the Correction factors proposed in the previous tables

A) Mixture Water and Glycol---Evaporator leaving water temperature > 4°C

- depending from the type and percentage (%) of glycol filled in the circuit (see table 3.2 and 5)
- multiply the Cooling Capacity, the Compressor Power Input by the Correction factor of Table 5
- starting from this new value of Cooling Capacity, calculate the Flow Rate (l/s) and the Evaporatore Pressure Drop (kPa)
- now multiply the new Flow Rate and the new Evaporator Pressure Drop by the Correction Factors of Table 5

Example

Unit size:	EWLD110J-SS
Mixture:	Water
Working condition:	ELWT 12/7°C - Saturated discharge temperature 45°C
- Cooling capacity:	110 kW
- Power input:	30.9 kW
- Flow Rate (Δt 5°C):	5.24
- Evaporator Pressure Drop:	14kPa
Mixture:	Water+Ethylene glycol 30% (for a winter air temperature up to -15°C)
Working condition:	ELWT 12/7°C - Saturated discharge temperature 45°C
- Cooling capacity:	110 x 0.972 = 107 kW
- Power input:	30.9 x 0.986 = 30.5 kW
- Flow Rate (Δt 5°C):	5.11 l/s (referred to 107 kW) x 1.074 = 5.49 l/s
- Evaporator Pressure Drop:	15 (referred to 5.49 l/s) x 1.181 = 18kPa

B) Mixture Water and Glycol---Evaporator leaving water temperature < 4°C

- depending from the type and percentage (%) of glycol filled in the circuit (see table 3.1 and 3.2 and table 5)
- depending from the evaporator leaving water temperature (see table 4)
- multiply the Cooling Capacity, the Compressor Power Input by the Correction factor of Table 4 and Table 5
- starting from this new value of Cooling Capacity, calculate the Flow Rate (l/s) and the Evaporatore Pressure Drop (kPa)
- now multiply the new Flow Rate and the new Evaporator Pressure Drop by the Correction Factors of Table 5

Example

Unit size:	EWLD110J-SS
Mixture:	Water
Working condition:	ELWT 12/7°C - Saturated discharge temperature 40°C
- Cooling capacity:	115 kW
- Power input:	28 kW
- Flow Rate (Δt 5°C):	5.49
- Evaporator Pressure Drop:	15kPa
Mixture:	Water+Ethylene glycol 30% (for a low evaporator leaving temperature of 0/-5°C)
Working condition:	ELWT 0/-5°C - Saturated discharge temperature 40°C
- Cooling capacity:	110 x 0.641 x 0.972 = 68.5 kW
- Power input:	28 x 0.880 x 0.986 = 24.3 kW
- Flow Rate (Δt 5°C):	3.27 l/s (referred to 68.5 kW) x 1.074 = 3.51 l/s
- Evaporator Pressure Drop:	7 kPa (referred to 3.51 l/s) x 1.181 = 9kPa

12 Specification text

12 - 1 Specification Text

12

Technical Specification for Water Cooled Screw Chiller

General

The water cooled screw chiller will be designed and manufactured in accordance with following European directives:

Construction of pressure vessel	97/23/EC (PED)
Machinery Directive	2006/42/EC
Low Voltage	2006/95/EC
Electromagnetic Compatibility	2004/108/EC
Electrical & Safety Codes	EN 60204-1 / EN 60335-2-40
Manufacturing Quality Stds	UNI - EN ISO 9001:2004

The unit will be tested at full load in the factory at the nominal working conditions and water temperatures. Before shipment a full test will be held to avoid any losses.

Chiller will be delivered to the job site completely assembled and charged with refrigerant and oil. Comply with the manufacturer instructions for rigging and handling equipment.

The unit will be able to start up and operate as standard at full load and saturated discharge temperature from . . . °C to . . . °C with an evaporator leaving fluid temperature between . . . °C and °C

All units published performances have to be certified by **Eurovent**.

Refrigerant

Only HFC 134a will be accepted.

Freeze protection

- ✓ Number of water cooled screw chiller:
- ✓ Cooling capacity for single water cooled screw chiller: kW
- ✓ Power input for single water cooled screw chiller in cooling mode: kW
- ✓ Plate to plate evaporator entering water temperature in cooling mode: °C
- ✓ Plate to plate evaporator leaving water temperature in cooling mode: °C
- ✓ Plate to plate evaporator water flow: l/s
- ✓ Saturated discharge temperature: °C
- ✓ The unit should work with electricity in range 400V ±10%, 3ph, 50Hz without neutral and shall only have one power connection point.

Unit description

Chiller shall include as standard: Chiller shall include as standard: 1 or 2 independent refrigerant circuits, semi-hermetic rotary single screw compressors, electronic expansion device (EEXV), direct expansion plate to plate evaporator, R134a refrigerant, lubrication system, motor starting components, control system and all components necessary for safe and stable unit operation. Chiller will be factory assembled on a robust base-frame made of zinc coated steel, protected by an epoxy paint.

Noise level and vibration

Sound pressure level at 1 meter distance in free field, semispheric conditions, shall not exceed dBA. The sound pressure levels must be rated in accordance to ISO 3744. Other types of rating unacceptable. Vibration level should not exceed 2 mm/s.

Dimension

Unit dimensions shall not exceed following indications:

- ✓ unit length: mm,
- ✓ unit width: mm,
- ✓ unit height: mm.

SPC_1-2-3_Rev.00_1

12 Specification text

12 - 1 Specification Text

Chiller Components

Compressors

- ✓ Semi-hermetic, single-screw type with one main helical rotor meshing with gaterotor. The gaterotor will be constructed of a carbon impregnated engineered composite material. The gaterotor supports will be constructed of cast iron.
- ✓ The oil injection shall be used in order to get high EER (Energy Efficiency Ratio) also at high condensing pressure and low sound pressure levels in each load condition.
- ✓ Refrigerant system differential pressure shall provide oil flow through service replaceable, 0.5 micron, full flow, cartridge type oil filter internal to compressor.
- ✓ Refrigerant system differential pressure shall provide oil injection on all moving compressor parts to correctly lubricate them. Electrical oil pump lubricating system is not acceptable.
- ✓ The compressor's oil cooling must be realized, when necessary, by refrigerant liquid injection. External dedicated heat exchanger and additional piping to carry the oil from the compressor to heat exchanger and viceversa will be not accepted.
- ✓ The compressor shall be provided with an external, high efficiency, cyclonic type oil separator and with built-in oil filter, cartridge type.
- ✓ The compressor shall be direct electrical driven, without gear transmission between the screw and the electrical motor.
- ✓ Shall be present two thermal protection realized by a thermistor for high temperature protection: one temperature sensor to protect electrical motor and another sensor to protect unit and lubricating oil from high discharge gas temperature.
- ✓ The compressor shall be equipped with an electric oil-crankcase heater.
- ✓ Compressor shall be fully field serviceable. Compressor that must be removed and returned to the factory for service shall be unacceptable.

Cooling capacity control system

- ✓ Each unit will have a microprocessor for the control of compressor slide valve's position and instantaneous RPM value of the motor.
- ✓ The unit capacity control shall be infinitely modulating, from 100% down to 25% for each circuit (from 100% down to 12,5% of full load for unit with 2 compressors). The chiller shall be capable of stable operation to a minimum of 12,5% of full load without hot gas bypass.
- ✓ Step unloading unacceptable because of evaporator leaving water temperature fluctuation and low unit efficiency at partial load.
- ✓ The system shall stage the unit based on the leaving evaporator water temperature fluctuation that shall be controlled by a PID (Proportional Integral Derivative) loop.
- ✓ Unit control logic shall to manage frequency level of the compressor electric motor to exactly match plant load request in order to keep constant the set point for delivered chilled water temperature. In this operation condition unit control logic shall modulate electrical frequency level in a range lower and upper the nominal electrical network value at 50 Hz.
- ✓ The microprocessor unit control shall detect conditions that approach protective limits and take self-corrective action prior to an alarm occurring. The system shall automatically reduce chiller capacity when any of the following parameters are outside their normal operating range:
 - High condenser pressure
 - Low evaporation refrigerant temperature
 - High compressor motor amps

Evaporator

- ✓ The units shall be equipped with a Direct Expansion plate to plate evaporator with copper tubes rolled into steel tubesheets.
- ✓ The external shell shall be linked with an electrical heater to prevent freezing down to -28°C ambient temperature, controlled by a thermostat and shall be insulated with flexible, closed cell polyurethane insulation material (10 mm thick).
- ✓ The evaporator will have 1 circuit.
- ✓ The water connections shall be threaded type connections as standard to ensure quick mechanical disconnection between the unit and the hydronic network.
- ✓ Evaporator is manufactured in accordance to PED approval.

SPC_1-2-3_Rev.00_2

12 Specification text

12 - 1 Specification Text

12

Refrigerant circuit

Each circuit shall include as standard: electronic expansion device piloted by unit's microprocessor control, compressor discharge shut-off valve, suction line shut-off valve, replaceable core filter-drier, sight glass with moisture indicator and insulated suction line.

Control panel

- ✓ Field power connection, control interlock terminals, and unit control system should be centrally located in an electric panel (IP 54). Power and starting controls should be separate from safety and operating controls in different compartments of the same panel.
- ✓ Starting shall be Wye-Delta type as standard.
- ✓ Operating and safety controls should include energy saving control; emergency stop switch; overload protection for compressor motor, high and low pressure cut-out switch (for each refrigerant circuit); anti-freeze thermostat; cut-out switch for each compressor.
- ✓ All of the information regarding the unit will be reported on a display and with the internal built-in calendar and clock that will switch the unit ON/OFF during day time all year long.
- ✓ The following features and functions shall be included:
 - Resetting chilled water temperature by controlling the return water temperature or by a remote 4-20 mA DC signal or by controlling the external ambient temperature;
 - Soft load function to prevent the system from operating at full load during the chilled fluid pulldown period;
 - Password protection of critical parameters of control;
 - Start-to-start and stop-to-start timers to provide minimum compressor off-time with maximum motor protection;
 - Communication capability with a PC or remote monitoring;
 - discharge pressure control through intelligent cycling of condenser fans;
 - Lead-lag selection by manual or automatically by circuit run hours;
 - Double set point for brine unit version;
 - Scheduling via internal time clock to allow programming of a yearly start-stop schedule accommodating weekends and holidays.

Optional High Level Communications Interface

The controller as a minimum shall be capable of providing the data shown in the above list, using the following options:

- RS485 Serial Card
- RS232 Serial Card
- LonWorks interface to FTT10A Transceiver.
- Bacnet Compatible
- Use of Compass Points (manufactured by North Communications) to allow communications with such as Honeywell, Satchwell, Johnson controls, Trend etc.

SPC_1-2-3_Rev.00_3

In all of us,
a green heart



Daikin's unique position as a manufacturer of air conditioning equipment, compressors and refrigerants has led to its close involvement in environmental issues. For several years Daikin has had the intention to become a leader in the provision of products that have limited impact on the environment. This challenge demands the eco design and development of a wide range of products and an energy management system, resulting in energy conservation and a reduction of waste.

The present leaflet is drawn up by way of information only and does not constitute an offer binding upon Daikin Europe N.V. Daikin Europe N.V. has compiled the content of this leaflet to the best of its knowledge. No express or implied warranty is given for the completeness, accuracy, reliability or fitness for particular purpose of its content and the products and services presented therein. Specifications are subject to change without prior notice. Daikin Europe N.V. explicitly rejects any liability for any direct or indirect damage, in the broadest sense, arising from or related to the use and/or interpretation of this leaflet. All content is copyrighted by Daikin Europe N.V.



Daikin Europe N.V. participates in the Eurovent Certification programme for Air Conditioners (AC), Liquid Chilling Packages (LCP) and Fan Coil Units (FC); the certified data of certified models are listed in the Eurovent Directory. Multi units are Eurovent certified for combinations up to 2 indoor units.



ECDEN11-423

Daikin products are distributed by: