

Chillers

Commercial and Technical Data

Water cooled chiller

- » **Wide capacity range
(120 kW - 570 kW)**
- » **Compact design**
- » **Indoor installations**
- » **Water supply down
to -10°C (optional)**
- » **New MicroTech III
controller**

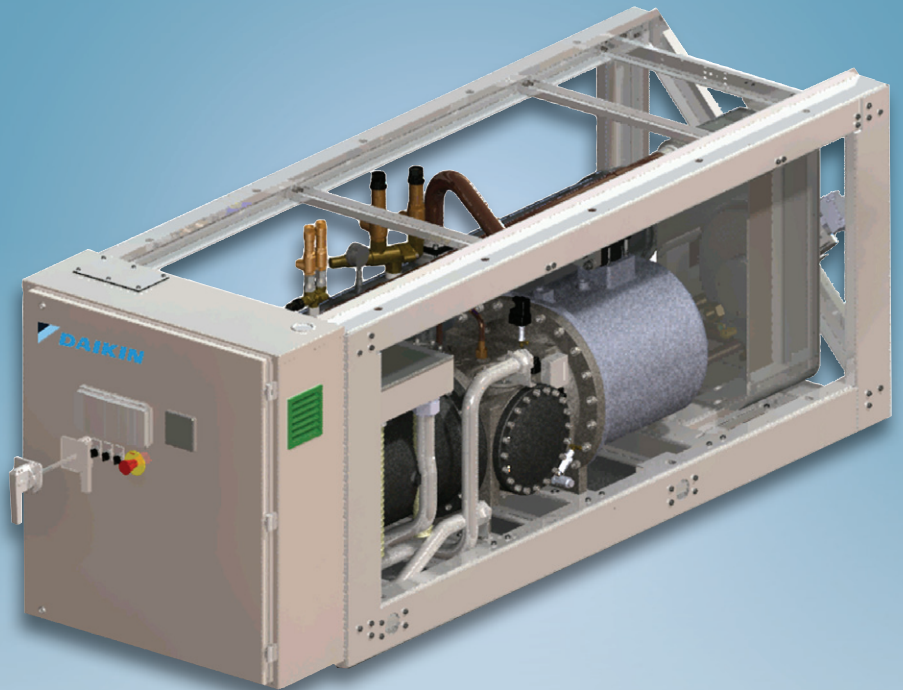

ECDEN11-413

EWWD~J-
120~570 kW

R-134a



Daikin Europe N.V.

About Daikin

Daikin has a worldwide reputation based on over 85 years' experience in the successful manufacture of high quality air conditioning equipment for industrial, commercial and residential use. Daikin's much envied quality quite simply stems from the close attention paid to design, production and testing, as well as aftersales support. To this end, every component is carefully selected and rigorously tested to verify its contribution to product quality and reliability.

New Daikin Compact line 'EWWD-J-' water cooled chiller range

In order to upgrade the water cooled chiller portfolio, Daikin enhances today the 'EWWD-J-' series, offering compact design, maximum efficiency and superior control logic.

The new range is composed of 16 sizes and available in standard efficiency version, with EER up to 4.41 and ESEER up to 5.37. Each unit is equipped with one or two R-134 refrigerant circuits, featuring shell & tube condenser, plate to plate evaporator and single screw compressor with stepless capacity control, allowing the chiller to modulate its capacity from 100% to 12.5%.

Moreover, the range features an extensive option list including the heat pump version, the energy meter and the sound proof system..



Table of Contents

CHILLER FEATURES	2
TECHNICAL DATA	5
1. Features and advantages	2
2. General characteristics	3
3. Nomenclature	4
4. Technical & electrical specifications	5
5. Sound Levels	6
6. Operating limits	7
7. Standard rating	8
8. Evaporator pressure drop	9
9. Options	10
10. Dimensions	11
11. Installation notes	12
12. Specification (for tender)	13



Chiller features

Application flexibility

The EWWD-J- series is available in a wide range of capacities (120 - 570kW), allowing project solutions for an extensive range of applications. The most commonly serviced parts are easily accessible, simplifying maintenance and service. Moreover, the new chillers allow flexible integration into a wide range of control and building management systems.

Large operation range

With the 'brine' option the new range is able to provide water down to -10°C , making the units suitable also for some typical industrial applications.

Extensive option list

The base model includes several standard factory mounted options such as: electronic expansion valve, wye delta starter (y-d), main switch interlock, etc. Moreover, the new range features an extensive option list, including the sound proof system, the automatic circuit breakers, the fork-lift kit, etc.

Compact design for indoor installations

Water cooled units are typically intended for indoor installation and operation, resulting in acoustic isolation and also zero impact on the building layout. Thanks to the compact design, the EWWD-J- series allow easy indoor installations and retrofit operations.

Superior control logic

The new MicroTech III controller provides an easy to use control environment. The control logic is designed to provide maximum efficiency, to continue operation in unusual operating conditions and to provide a history of unit operation. One of the greatest benefits is the easy interface with Lonwork, BACnet, Ethernet TCP/IP or Modbus communications.

TABLE OF CONTENTS

EWWD-J-SS

1	Features	2
2	Specifications	3
	Technical Specifications	3
	Electrical Specifications	5
3	Features and advantages	8
	Features and Advantages	8
4	General Characteristics	10
	General characteristics	10
5	Nomenclature	14
	Nomenclature	14
6	Capacity tables	15
	Cooling Capacity Tables	15
7	Pressure drops	21
	Evaporator Pressure Drops	21
8	Dimensional drawings	22
	Dimensional Drawings	22
9	Sound data	24
	Sound Level Data	24
10	Installation	25
	Installation Method	25
	Water Charge, Flow and Quality	26
11	Operation range	28
	Operation Range	28
12	Specification text	31
	Specification Text	31

1 Features

- Compact design to allow easy indoor installation or retrofit operations
- Chilled water temperatures down to -10°C on standard unit
- Daikin semi-hermetic single screw stepless compressor
- Optimised for use with R-134a
- High efficiency at full and partial load
- MicroTech III controller

1

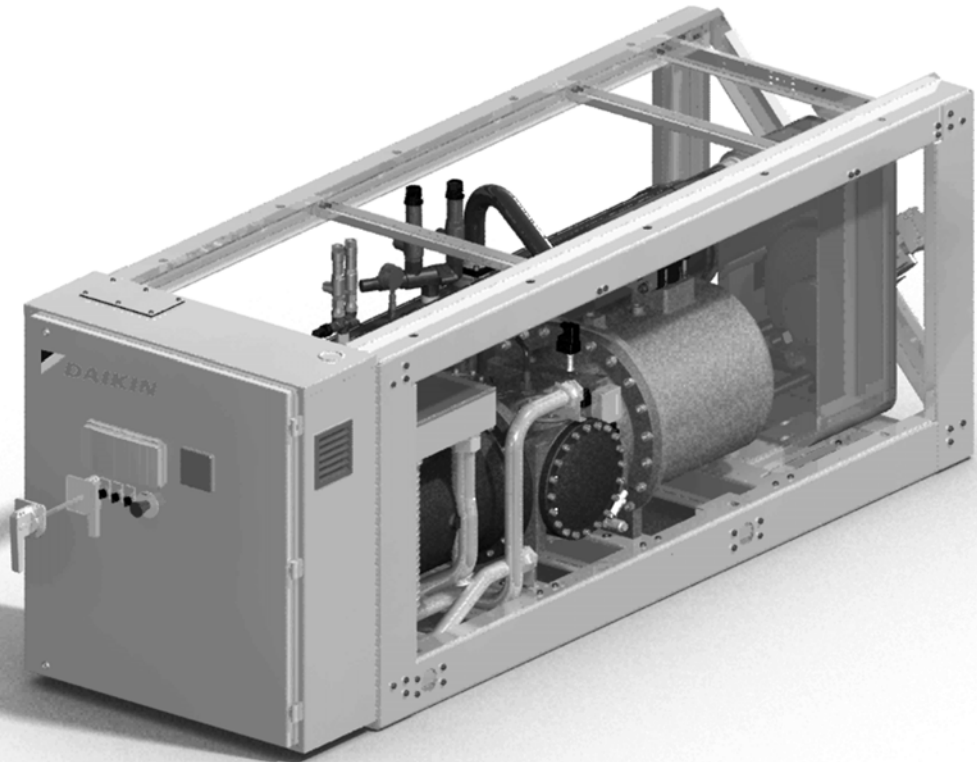

2

2 Specifications

2-1 Technical Specifications				EWWD120J-SS	EWWD140J-SS	EWWD150J-SS	EWWD180J-SS	EWWD210J-SS	EWWD250J-SS		
Cooling capacity	Nom.	kW		120 (1)	146 (1)	155 (1)	178 (1)	208 (1)	256 (1)		
Heating capacity	Nom.	kW		142 (2)	172 (2)	188 (2)	216 (2)	249 (2)	305 (2)		
Capacity control	Method			Stepless							
	Minimum capacity			25							
Power input	Cooling	Nom.	kW	27.3 (1)	33.3 (1)	38.5 (1)	44.2 (1)	49.3 (1)	58.7 (1)		
	Heating	Nom.	kW	32.9 (2)	40.1 (2)	46.4 (2)	53.5 (2)	59.57 (2)	71.68 (2)		
EER				4.40 (1)	4.38 (1)	4.03 (1)		4.22 (1)	4.37 (1)		
COP				4.32 (2)	4.29 (2)	4.05 (2)	4.04 (2)	4.18 (2)	4.26 (2)		
ESEER				5.01	4.67		4.66	4.75	5.20		
Casing	Colour			Ivory white							
	Material			Galvanized and painted steel sheet							
Dimensions	Unit	Height		mm		1,020					
		Width		mm		913					
		Depth		mm		2,684					
Weight	Unit		kW	1,177	1,233	1,334	1,366	1,416	1,600		
	Operation weight		kW	1,211	1,276	1,378	1,415	1,473	1,663		
Water heat exchanger	Type			Brazen plate, one per circuit							
Water heat exchanger - evaporator	Water volume			l		14	18	14	17	20	26
	Water flow rate		Nom.	l/s		5.73	6.98	7.41	8.50	9.94	12.25
	Nominal water pressure drop	Cooling	Heat exchanger	kPa		15	13	40	38	36	28
	Insulation material			Closed cell							
Water heat exchanger - condenser	Type			Double pass shell and tube							
	Water flow rate		Nom.	l/s		7.04	8.57	9.25	10.62	12.30	15.06
	Nominal water pressure drop	Cooling		kPa		20	12	11		16	
	Insulation material			Closed cell							
	Model	Quantity			1						
Sound power level	Cooling	Nom.	dBA		71.4 (3)				70.0 (3)		
Sound pressure level	Cooling	Nom.	dBA		88.6 (3)				87.2 (3)		
Compressor	Type			Semi-hermetic single screw compressor							
	Quantity			1							
	Oil	Charged volume		l		13			-		
Operation range	Evaporator	Cooling	Min.	°CDB		-10					
			Max.	°CDB		15					
	Condenser	Cooling	Min.	°CDB		23					
			Max.	°CDB		60					
Refrigerant	Type			R-134a							
	Charge		kW	18	20	33	34	36	38		
	Circuits	Quantity			1						
Piping connections	Evaporator water inlet/outlet			mm		76.2					
	Condenser water inlet/outlet (OD)			2" 1/2		4"					
Safety devices	Item	01		High discharge pressure (pressure switch)							
		02		High discharge pressure (pressure transducer)							
		03		Low suction pressure (pressure transducer)							
		04		Compressor motor protection							
		05		High discharge temperature							
		06		Low oil pressure							
		07		Low pressure ratio							
		08		High oil filter pressure drop							
		09		Phase monitor							
		10		Emergency stop button							
		11		Water freeze protection controller							

2-1 Technical Specifications				EWWD280J-SS	EWWD310J-SS	EWWD330J-SS	EWWD360J-SS	EWWD380J-SS	EWWD400J-SS
Cooling capacity	Nom.	kW		285 (1)	310 (1)	334 (1)	357 (1)	386 (1)	416 (1)
Heating capacity	Nom.	kW		340 (2)	377 (2)	405 (2)	432 (2)	466 (2)	499 (2)

2 Specifications

2

2-1 Technical Specifications				EWWD280J-SS	EWWD310J-SS	EWWD330J-SS	EWWD360J-SS	EWWD380J-SS	EWWD400J-SS		
Capacity control	Method			Stepless							
	Minimum capacity			25	12.5						
Power input	Cooling	Nom.	kW	68.3 (1)	77 (1)	82.7 (1)	88.4 (1)	98.6 (1)			
	Heating	Nom.	kW	80.75 (2)	92.88 (2)	99.9 (2)	107 (2)	113 (2)	119 (2)		
EER				4.18 (1)	4.03 (1)	4.04 (1)		3.91 (1)	4.22 (1)		
COP				4.21 (2)	4.06 (2)	4.05 (2)	4.04 (2)	4.12 (2)	4.19 (2)		
ESEER				4.46	4.80	4.84	5.00	4.79	5.17		
Casing	Colour			Ivory white							
	Material			Galvanized and painted steel sheet							
Dimensions	Unit	Height		mm	1,020	2,000					
		Width		mm	913						
		Depth		mm	2,684						
Weight	Unit			kg	1,607	2,668	2,700	2,732	2,782	2,832	
	Operation weight			kg	1,675	2,755	2,792	2,830	2,888	2,946	
Water heat exchanger	Type			Braze plate, one per circuit							
Water heat exchanger - evaporator	Water volume			l	26	29	31	33	37	41	
	Water flow rate	Nom.		l/s	13.63	14.81	15.96	17.06	18.44	19.88	
	Nominal water pressure drop	Cooling	Heat exchanger		kPa	33	40		38		36
			Insulation material			Closed cell					
Water heat exchanger - condenser	Type			Double pass shell and tube							
	Water flow rate	Nom.		l/s	16.89	18.49	19.91	21.28	23.15	24.59	
	Nominal water pressure drop	Cooling			kPa	26	11				
			Insulation material			Closed cell					
	Model	Quantity			1						
Sound power level	Cooling	Nom.		dBA	70.0 (3)	74.4 (3)					
Sound pressure level	Cooling	Nom.		dBA	87.2 (3)	92.4 (3)					
Compressor	Type			Semi-hermetic single screw compressor							
	Quantity			1	2						
	Oil	Charged volume		l	-			26			
Operation range	Evaporator	Cooling	Min.	°CDB	-10						
			Max.	°CDB	15						
	Condenser	Cooling	Min.	°CDB	23						
			Max.	°CDB	60						
Refrigerant	Type			R-134a							
	Charge			kg	38	66	67	68	70	72	
	Circuits	Quantity			1	2					
Piping connections	Evaporator water inlet/outlet			mm	76.2						
	Condenser water inlet/outlet (OD)			4"							
Safety devices	Item	01		High discharge pressure (pressure switch)							
		02		High discharge pressure (pressure transducer)							
		03		Low suction pressure (pressure transducer)							
		04		Compressor motor protection							
		05		High discharge temperature							
		06		Low oil pressure							
		07		Low pressure ratio							
		08		High oil filter pressure drop							
		09		Phase monitor							
		10		Emergency stop button							
		11		Water freeze protection controller							

2-1 Technical Specifications				EWWD450J-SS	EWWD500J-SS	EWWD530J-SS	EWWD560J-SS	
Cooling capacity	Nom.			kW	464 (1)	513 (1)	541 (1)	570 (1)
Heating capacity	Nom.			kW	554 (2)	610 (2)	645 (2)	681 (2)
Capacity control	Method			Stepless				
	Minimum capacity			%	12.5			

4

2 Specifications

2-1 Technical Specifications				EWWD450J-SS	EWWD500J-SS	EWWD530J-SS	EWWD560J-SS		
Power input	Cooling	Nom.	kW	108 (1)	117 (1)	127 (1)	137 (1)		
	Heating	Nom.	kW	131 (2)	143 (2)	152 (2)	162 (2)		
EER				4.30 (1)	4.38 (1)	4.26 (1)	4.16 (1)		
COP				4.22 (2)	4.26 (2)	4.23 (2)	4.22 (2)		
ESEER				5.27	5.37	5.25	4.81		
Casing	Colour			Ivory white					
	Material			Galvanized and painted steel sheet					
Dimensions	Unit	Height		2,000					
		Width		913					
		Depth		2,684					
Weight	Unit			kg	3,016	3,200	3,207	3,215	
	Operation weight			kg	3,136	3,327	3,338	3,350	
Water heat exchanger	Type			Braze plate, one per circuit					
Water heat exchanger - evaporator	Water volume			l	46	52			
	Water flow rate	Nom.		l/s	22.17	24.51	25.85	27.23	
	Nominal water pressure drop	Cooling	Heat exchanger		kPa	36	28		33
			Insulation material			Closed cell			
Water heat exchanger - condenser	Type			Double pass shell and tube					
	Water flow rate	Nom.		l/s	27.33	30.10	31.92	33.78	
	Nominal water pressure drop	Cooling			kPa	11	16		26
			Insulation material			Closed cell			
	Model	Quantity			1				
Sound power level	Cooling	Nom.		dBA	73.8 (3)	73.0 (3)			
Sound pressure level	Cooling	Nom.		dBA	91.8 (3)	91.0 (3)			
Compressor	Type			Semi-hermetic single screw compressor					
	Quantity			2					
	Oil	Charged volume		l	29	32			
Operation range	Evaporator	Cooling	Min.	°CDB	-10				
			Max.	°CDB	15				
	Condenser	Cooling	Min.	°CDB	23				
			Max.	°CDB	60				
Refrigerant	Type			R-134a					
	Charge			kg	74	76			
	Circuits	Quantity			2				
Piping connections	Evaporator water inlet/outlet			mm	76.2				
	Condenser water inlet/outlet (OD)			4"					
Safety devices	Item	01		High discharge pressure (pressure switch)					
		02		High discharge pressure (pressure transducer)					
		03		Low suction pressure (pressure transducer)					
		04		Compressor motor protection					
		05		High discharge temperature					
		06		Low oil pressure					
		07		Low pressure ratio					
		08		High oil filter pressure drop					
		09		Phase monitor					
		10		Emergency stop button					
		11		Water freeze protection controller					

2-2 Electrical Specifications				EWWD120J-SS	EWWD140J-SS	EWWD150J-SS	EWWD180J-SS	EWWD210J-SS	EWWD250J-SS	
Compressor	Phase			3~						
	Voltage			V						400
	Voltage range	Min.		%						-10
		Max.		%						10
	Maximum running current			A	80	96	107	121	145	161
Starting method				Wye-delta						

2 Specifications

2

2-2 Electrical Specifications			EWWD120J-SS	EWWD140J-SS	EWWD150J-SS	EWWD180J-SS	EWWD210J-SS	EWWD250J-SS	
Power supply	Phase		3~						
	Frequency	Hz	50						
	Voltage	V	400						
	Voltage range	Min.	%	-10					
		Max.	%	10					
Unit	Maximum starting current		A	151		195		288	
	Nominal running current (RLA)	Cooling	A	47 (6)	57 (6)	68 (6)	75 (6)	85 (6)	99 (6)
			A	80	96	107	121	145	161
	Maximum running current		A	88	106	118	133	160	177
Max unit current for wires sizing		A	88	106	118	133	160	177	

2-2 Electrical Specifications			EWWD280J-SS	EWWD310J-SS	EWWD330J-SS	EWWD360J-SS	EWWD380J-SS	EWWD400J-SS	
Compressor	Phase		3~						
	Voltage	V	400						
	Voltage range	Min.	%	-10					
		Max.	%	10					
	Maximum running current		A	182	107	121		145	
Starting method		Wye-delta							
Power supply	Phase		3~						
	Frequency	Hz	50						
	Voltage	V	400						
	Voltage range	Min.	%	-10					
		Max.	%	10					
Unit	Maximum starting current		A	288	281	292		311	
	Nominal running current (RLA)	Cooling	A	113 (6)	135 (6)	143 (6)	150 (6)	160 (6)	169 (6)
			A	182	214	228	242	266	290
	Maximum running current		A	200	235	251	266	293	319
Max unit current for wires sizing		A	200	235	251	266	293	319	

2-2 Electrical Specifications			EWWD450J-SS	EWWD500J-SS	EWWD530J-SS	EWWD560J-SS		
Compressor	Phase		3~					
	Voltage	V	400					
	Voltage range	Min.	%	-10				
		Max.	%	10				
	Maximum running current		A	145	161		182	
Starting method		Wye-delta						
Power supply	Phase		3~					
	Frequency	Hz	50					
	Voltage	V	400					
	Voltage range	Min.	%	-10				
		Max.	%	10				
Unit	Maximum starting current		A	404	417	434		
	Nominal running current (RLA)	Cooling	A	183 (6)	197 (6)	212 (6)		226 (6)
			A	306	322	343	364	
	Maximum running current		A	337	354	377	400.4	
Max unit current for wires sizing		A	337	354	377	400.4		

Notes

- (1) Cooling: entering evaporator water temp. 12°C; leaving evaporator water temp. 7°C; entering condenser water temp. 30°C; leaving condenser water temp. 35°C; full load operation.
- (2) Heating: entering evaporator water temp. 12°C; leaving evaporator water temp. 7°C; entering condenser water temp. 40°C; leaving condenser water temp. 45°C; unit at full load operation
- (3) Sound level data are measured at entering evaporator water temp. 12°C; leaving evaporator water temp. 7°C; entering condenser water temp. 30°C; leaving condenser water temp. 35°C; full load operation; standard: ISO3744
- (4) Allowed voltage tolerance ± 10%. Voltage unbalance between phases must be within ± 3%.
- (5) Maximum starting current: starting current of biggest compressor + current of the other compressor at 75 % of maximum load

2 Specifications

(6) Nominal current in cooling mode: entering evaporator water temp. 12°C; leaving evaporator water temp. 7°C; entering condenser water temp. 30°C; leaving condenser water temp. 35°C; compressors.

(7) Maximum running current is based on max compressor absorbed current in its envelope

(8) Maximum unit current for wires sizing is based on minimum allowed voltage.

(9) Maximum current for wires sizing: compressor full load ampere x 1.1

(10) Maximum starting current: starting current of biggest compressor + current of the other compressor at 75 % of maximum load + fans current

3 Features and advantages

3 - 1 Features and Advantages

Features and advantages

The EWWD-J- water cooled chillers, featuring 1 or 2 single screw compressors, are manufactured to satisfy the requirements of the consultants and the end user. Units are designed to minimise energy costs while maximising the refrigeration capacities. Daikin’s chiller design experience, combined with outstanding features makes the EWWD-J- chiller unmatched in the industry.

Seasonal quietness

The compressor design with a single screw and twin rotors allows a constant gas flow. This compression process completely eliminates gas pulsations. The oil injection also results in significant mechanical noise reduction. The twin gas compressor discharge chambers are designed to act as attenuators, based on the harmonic wave principle with destructive interference, thus always resulting equal to zero. The extremely low noise compressor performance affords the use of EWWD-J- chiller for all applications. The reduced number of vibrations produced from the EWWD-J- chiller offers a surprisingly quiet operation eliminating the noise transmission through the structure and the chilled water piping system.

Infinitely capacity control

Cooling capacity control is infinitely variable by means of a screw compressor controlled by microprocessor system. Each unit has infinitely variable capacity control from 100% down to 25% (one compressor unit), down to 12,5% (two compressors units). This modulation allows the compressor capacity to exactly match the building cooling load without any leaving evaporator water temperature fluctuation. This chilled water temperature fluctuation is avoided only with a stepless control.

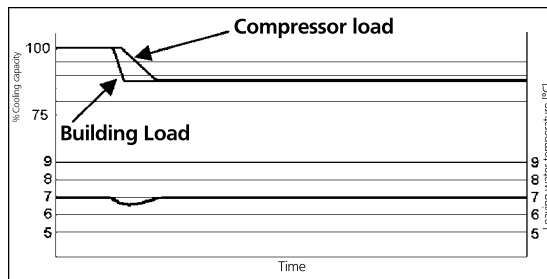

EWLТ fluctuation with stepless capacity control

With a compressor load step control in fact, the compressor capacity, at partial loads, will be too high or too low compared to the building cooling load. The result is an increase in chiller energy costs, particularly at the part-load conditions at which the chiller operates most of the time.

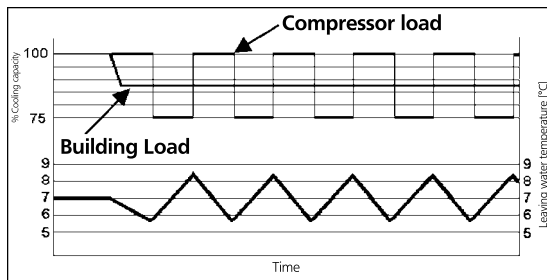

EWLТ fluctuation with steps capacity control (4 steps)

Units with stepless regulation offer benefits that the units with step regulation are unable to match. The ability to follow the system energy demand at any time and the possibility to provide steady outlet water temperature without deviations from the set-point, are the two points that allow you to understand how the optimum operating conditions of a system can be met only through the use of a unit with step-less regulation.

Code requirements - Safety and observant of laws/directives

All water cooled units are designed and manufactured in accordance with applicable selections of the following:

Construction of pressure vessel	97/23/EC (PED)
Machinery Directive	2006/42/EC
Low Voltage	2006/95/EC
Electromagnetic Compatibility	2004/108/EC
Electrical & Safety Codes	EN 60204-1/EN 60335-2-40
Manufacturing Quality Stds	UNI - EN ISO 9001:2004

FTA_1-2_Rev.00_1

3 Features and advantages

3 - 1 Features and Advantages

Certifications

All units manufactured are CE marked, complying with European directives in force, concerning manufacturing and safety. On request units can be produced complying with laws in force in non European countries (ASME, GOST, etc.), and with other applications, such as naval (RINA, etc.).

Versions

EWWD-J- is available in standard efficiency version:

S: Standard Efficiency

16 sizes, covering a cooling capacity range from 121 up to 571 kW, EER up to 4.41 and ESEER up to 5.37.

The EER (Energy Efficiency Ratio) is the ratio of the Cooling Capacity to the Power Input of the unit. The Power Input includes: the power input for operation of the compressor, the power input of all control and safety devices.

The ESEER (European Seasonal Energy Efficiency Ratio) is a weighed formula enabling to take into account the variation of EER with the load rate and the variation of water inlet condenser temperature.

$$ESEER = A \times EER_{100\%} + B \times EER_{75\%} + C \times EER_{50\%} + D \times EER_{25\%}$$

	A	B	C	D
Coefficient	0.03 (3%)	0.33 (33%)	0.41 (41%)	0.23 (23%)
Condenser water inlet temperature (°C)	30	26	22	18

Sound configuration

EWWD-J- is available in standard sound level configuration:

S: Standard Noise

FTA_1-2_Rev.00_2

4 General Characteristics

4 - 1 General characteristics

General characteristics

Cabinet and structure

The cabinet is made of galvanized steel sheet and painted to provide a high resistance to corrosion. Colour Ivory White (Munsell code 5Y7.5/1) (±RAL7044). The base frame has eye-hook for lifting the unit with ropes for an easy installation. The weight is uniformly distributed along the profiles of the base and this facilitates the arrangement of the unit.

Screw compressors

The compressor is semi-hermetic, single-screw type with gate-rotors made of carbon impregnated engineered composite material. The compressor has one slide managed by the unit microprocessor for infinitely modulating the capacity between 100% to 25%. An integrated high efficiency oil separator maximizes the oil separation and standard start is Wye-delta (Y- Δ) type.

Ecological HFC 134a refrigerant

The compressors have been designed to operate with R-134a, ecological refrigerant with zero ODP (Ozone Depletion Potential) and very low GWP (Global Warming Potential) that means low TEWI (Total Equivalent Warming Impact).

Evaporator

The units are equipped with direct expansion plate to plate type evaporator, one per circuit. This heat exchanger is made of stainless steel brazed plates and is covered with a 10mm closed cell insulation material. The evaporator is manufactured in accordance to PED approval. The evaporator water outlet connections are provided with Victaulic Kit (as standard).

Condenser

The units are equipped with Direct Expansion shell & tube condenser, with copper tubes rolled into steel tube sheets. The unit has independent condensers, one per circuit. The condenser is manufactured in accordance to PED approval.

Condensers are provided with liquid shut-off valve and spring loaded relief valve.

The condenser water outlet connections are provided with Victaulic Kit (as standard).

Electronic expansion valve

The unit is equipped with the most advanced electronic expansion valves to achieve precise control of refrigerant mass flow. As today's system requires improved energy efficiency, tighter temperature control, wider range of operating conditions and incorporate features like remote monitoring and diagnostics, the application of electronic expansion valves becomes mandatory.

Electronic expansion valve proposes features that makes it unique: short opening and closing time, high resolution, positive shut-off function to eliminate use of additional solenoid valve, highly linear flow capacity, continuous modulation of mass flow without stress in the refrigerant circuit and corrosion resistance stainless steel body.

EEV strength point is the capacity to work with lower ΔP between high and low pressure side, than a thermostatic expansion valve. The electronic expansion valve allows the system to work with low condenser pressure (winter time) without any refrigerant flow problems and with a perfect chilled water leaving temperature control.

Refrigerant circuit

Each unit has independent refrigerant circuits and each one includes:

- Single screw compressor with integrated oil separator
- Brazed plate evaporator
- Shell & tube condenser
- Oil pressure transducer
- High pressure switches
- High pressure transducer
- Low pressure transducer
- Moisture liquid indicator
- Replaceable core filter-drier
- Electronic expansion valve

GNC_1-2-3-4_Rev.00_1

4 General Characteristics

4 - 1 General characteristics

Electrical control panel

Power and control are located in the main panel that is manufactured to ensure protection against all weather conditions. The electrical panel is IP54 and (when opening the doors) internally protected with Plexiglas panel against possible accidental contact with electrical components (IP20). The main panel is fitted with a main switch interlocked door.

Power section

The power section includes compressors fuses and control circuit transformer.

MicroTech III controller

MicroTech III controller is installed as standard; it can be used to modify unit set-points and check control parameters. A built-in display shows chiller operating status plus temperatures and pressures of water, refrigerant, programmable values, set-points. A sophisticated software with predictive logic, selects the most energy efficient combination of compressors and electronic expansion valve to keep stable operating conditions to maximise chiller energy efficiency and reliability. MicroTech III is able to protect critical components based on external signs from its system (such as motor temperatures, refrigerant gas and oil pressures, correct phase sequence, pressure switches and evaporator). The input coming from the high pressure switch cuts all digital output from the controller in less than 50ms, this is an additional security for the equipment. Fast program cycle (200ms) for a precise monitoring of the system. Floating point calculations supported for increased accuracy in P/T conversions.

Control section - main features:

- Management of the compressor stepless capacity.
- Chiller enabled to work in partial failure condition.
- Full routine operation at condition of:
 - high ambient temperature value
 - High thermal load
 - High evaporator entering water temperature (start-up)
- Display of evaporator entering/leaving water temperature.
- Display of condensing-evaporating temperature and pressure, suction and discharge superheating temperature for each circuit.
- Leaving water evaporator temperature regulation. Temperature tolerance = 0,1°C.
- Compressor and evaporator pumps hour counters.
- Display of Status Safety Devices.
- Number of starts and compressor working hours.
- Optimized management of compressor load.
- Re-start in case of power failure (Automatic / Manual).
- Soft Load (optimized management of the compressor load during the start-up).
- Start at high evaporator water temperature.
- Return Reset (Set Point Reset based on return water temperature).
- Setpoint Reset (optional).
- Application and system upgrade with commercial SD cards.
- Ethernet port for remote or local servicing using standard web browsers.
- Two different sets of default parameters could be stored for easy restore.

Safety device / logic for each refrigerant circuit

- High pressure (pressure switch).
- High pressure (transducer).
- Low pressure (transducer).
- High compressor discharge temperature.
- High motor winding temperature.
- Phase monitor.
- Low pressure ratio.
- High oil pressure drop.
- Low oil pressure.
- No pressure change at start.

GNC_1-2-3-4_Rev.00_2

4 General Characteristics

4 - 1 General characteristics

4

System security

- Phase monitor.
- Low Ambient temperature lock-out.
- Freeze protection.

Regulation type

Proportional + integral + derivative regulation on the evaporator leaving water output probe.

Microtech III

MicroTech III built-in terminal has the following features.

- 164x44 dots liquid crystal display with white back lighting. Supports Unicode fonts for multi-lingual.
- Key-pad consisting of 3 keys.
- Push'n'Roll control for an increased usability.
- Memory to protect the data.
- General faults alarm relays.
- Password access to modify the setting.
- Application security to prevent application tampering or hardware usability with third party applications.
- Service report displaying all running hours and general conditions.
- Alarm history memory to allow an easy fault analysis.

Supervising systems (on request)

MicroTech III remote control

MicroTech III is able to communicate to BMS (Building Management System) based on the most common protocols as:

- ModbusRTU
- LonWorks, now also based on the international 8040 Standard Chiller Profile and LonMark Technology.
- BacNet BTP certified over IP and MS/TP (class 4) (Native).

Chiller Sequencing

MicroTech III controller allows an easy plug-in sequencing technology based on digital or serial panel

Digital Sequencing Panel

This panel is basically a step inserter that switches ON/OFF up to 11 units (chillers or heat pumps operating in the same cooling/heating mode) depending on the selected set point, the units are connected with the panel through standard cables and no serial card is requested.

Serial Sequencing Panel

Basically this panel sequences a chiller plant by switching on/off the units (up to 7 chillers) taking into account their running hours and the requested plant load, in order to optimise the number of working units for each condition; serial cards and shielded cables are requested to connect the panel with the units and, if installed, a BMS.

Standard accessories (supplied on basic unit)

Evaporator Victaulic Kit - Hydraulic joint with gasket for an easy and quick water connection.

20mm Evaporator Insulation

Condenser Victaulic kit

Condenser Water side design pressure 16 bar

Condenser 2 passes (Δt 4-8°C)

Suction line shut off valve - Suction shut-off valve installed on the suction of the compressor to facilitate maintenance operation.

Discharge line shut-off valves - Discharge shut-off valve installed on the discharge of the compressor to facilitate maintenance operations.

Electronic expansion valve

GNC_1-2-3-4_Rev.00_3

4 General Characteristics

4 - 1 General characteristics

High Pressure Side Manometers

Y-D starter - Star Delta starter is the standard type

Double set-point - Dual leaving water temperature set-points.

Phase monitor - The phase monitor controls that phases sequence is correct and controls phase loss.

Evaporator flow switch for the water piping.

Hour run meter - Digital compressors hour run meter.

General fault contactor - Contactor for alarm warning.

Main switch interlock

Emergency stop

Options (on request)

Heat pump version

Brine version - Allows the unit to operate down to -8°C leaving liquid temperature (antifreeze required).

Compressor thermal overload relays - Safety devices against compressor motor overloading in addition to the normal protection envisaged by the electrical windings.

Evaporator Water side design pressure 16 bar

20mm Condenser insulation

Condenser double flanges kit

Water pressure differential switch on evaporator

Sound Proof System - Compressor sound enclosure.

Rubber type antivibration mounts - Supplied separately, these are positioned under the base of the unit during installation. Ideal to reduce the vibrations when the unit is floor mounted.

Fork lift kit

Low pressure side manometers

Dual Pressure Relief Valve on evaporator

Under/Over Voltage - This device control the voltage value of power supply and stop the chiller if the value exceeds the allowed operating limits.

Energy Meter - This device allows to measure the energy absorbed by the chiller during its life.

It is installed inside the control box mounted on a DIN rail and show on a digital display: Line-to-Line Voltage, Phase and Average Current, Active and Reactive Power, Active Energy, Frequency.

Condenser power factor correction - Installed on the electrical control panel to ensure it complies with the plant rules. (Daikin advises maximum 0,9).

Current limit display

Witness test - Every unit is always tested at the test bench prior to the shipment. On request, a second test can be carried out, at customer's presence, in accordance with the procedures indicated on the test form. (Not available for units with glycol mixtures)

Acoustic test - On request, a test can be carried out, at customer's presence (please contact the factory) (This test is not available for units with glycol mixtures).

Set-point reset, demand limit and alarm from external device - The leaving water temperature set-point can be overwritten with the following options: 4-20mA from external source (by user), outside ambient temperature; evaporator water temperature Δt . Moreover the device allow the user to limit the load of the unit by 4-20mA signal or by network system and the microprocessor is able to receive an alarm signal from an external device (pump etc... - user can decide if this alarm signal will stop or not the unit).

Automatic circuit breakers

GNC_1-2-3-4_Rev.00_4

5 Nomenclature

5 - 1 Nomenclature

5

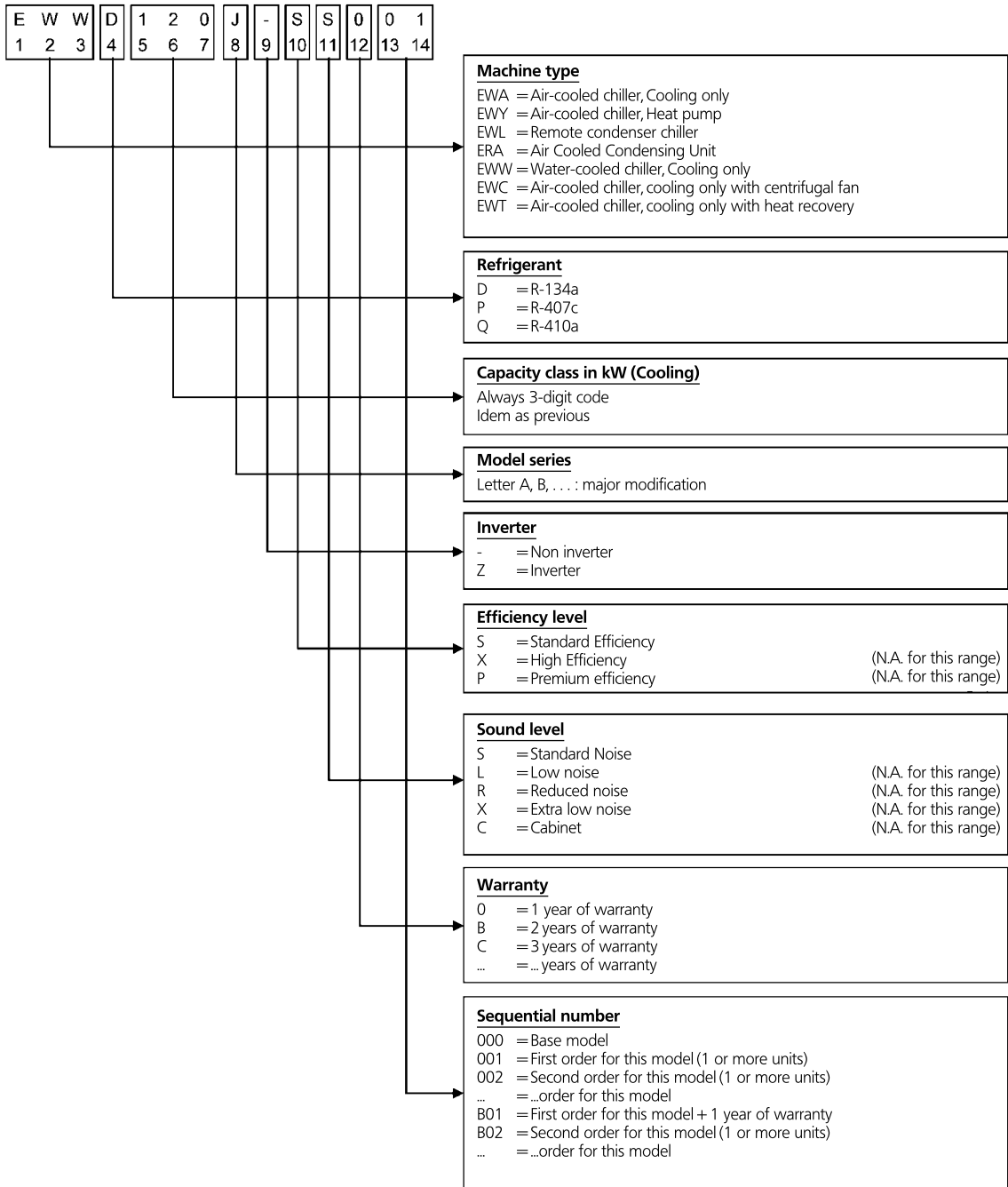

NMC_1_Rev.00_1

6 Capacity tables

6 - 1 Cooling Capacity Tables

EWWD120-250J-SS

Unit	EWLT (°C)	Entering condenser water temp. (°C)												
		15			20			25			30			
		Cc(kW)	Pi(kW)	Hc(kW)	Cc(kW)	Pi(kW)	Hc(kW)	Cc(kW)	Pi(kW)	Hc(kW)	Cc(kW)	Pi(kW)	Hc(kW)	
120	4				118	21.7	139	113	23.9	137	108	26.4	135	
	5				122	22.0	144	117	24.2	141	112	26.7	139	
	6				126	22.3	148	121	24.5	145	116	27.0	143	
	7				130	22.6	152	125	24.8	150	120	27.3	147	
	8				134	22.9	157	129	25.1	154	124	27.6	152	
	9				138	23.2	161	133	25.4	159	128	27.9	156	
	10							137	25.8	163	132	28.2	160	
	11							142	26.1	168	136	28.6	165	
	12							146	26.4	172	140	28.9	169	
	13							150	26.7	177	145	29.2	174	
	14							155	27.1	182	149	29.6	179	
	15							159	27.4	186	153	29.9	183	
	140	4				143	26.5	169	137	29.2	166	131	32.2	163
		5				148	26.8	174	142	29.6	172	136	32.6	168
		6				153	27.2	180	147	29.9	177	141	32.9	174
7					158	27.5	185	152	30.3	182	146	33.3	179	
8					163	27.9	191	157	30.6	188	151	33.6	184	
9					168	28.2	197	162	31.0	193	156	34.0	190	
10								168	31.4	199	161	34.4	195	
11								173	31.8	205	166	34.8	201	
12								178	32.1	210	171	35.2	207	
13								184	32.5	216	177	35.6	212	
14								189	32.9	222	182	36.0	218	
15								195	33.3	228	188	36.4	224	
150		4				153	30.8	183	147	34.1	181	141	37.5	179
		5				157	31.1	188	152	34.4	186	146	37.9	184
		6				162	31.4	193	156	34.7	191	151	38.2	189
	7				167	31.7	198	161	35.0	196	155	38.5	194	
	8				171	32.1	203	166	35.4	201	160	38.9	199	
	9				176	32.4	209	171	35.7	206	165	39.3	204	
	10							176	36.1	212	169	39.6	209	
	11							180	36.5	217	174	40.0	214	
	12							186	36.8	222	179	40.4	220	
	13							191	37.2	228	184	40.8	225	
	14							196	37.6	233	189	41.1	230	
	15							201	38.0	239	194	41.6	236	
	180	4				175	35.2	210	169	38.9	208	162	43.0	205
		5				181	35.6	216	174	39.4	214	167	43.4	211
		6				186	36.0	222	180	39.8	220	173	43.8	217
7					192	36.4	228	185	40.2	225	178	44.2	222	
8					198	36.8	234	191	40.6	231	184	44.7	229	
9					203	37.3	241	197	41.0	238	190	45.1	235	
10								202	41.4	244	195	45.5	241	
11								208	41.9	250	201	46.0	247	
12								214	42.3	257	207	46.5	253	
13								221	42.8	263	213	46.9	260	
14								227	43.3	270	219	47.4	266	
15								233	43.7	277	225	47.9	273	
210		4				205	39.2	244	197	43.5	240	189	47.9	237
		5				211	39.6	251	203	43.9	247	195	48.4	244
		6				217	40.0	257	209	44.4	254	202	48.9	250
	7				224	40.5	264	216	44.8	260	208	49.3	257	
	8				230	40.9	271	222	45.3	267	214	49.8	264	
	9				237	41.4	278	229	45.7	274	221	50.2	271	
	10							235	46.2	281	227	50.7	278	
	11							242	46.7	289	234	51.2	285	
	12							249	47.2	296	240	51.7	292	
	13							256	47.7	303	247	52.2	299	
	14							263	48.2	311	254	52.7	307	
	15							270	48.7	319	261	53.2	314	
	250	4				252	46.4	299	242	51.5	294	233	57.2	290
		5				261	46.9	308	250	52.0	302	239	57.6	297
		6				270	47.4	317	259	52.6	312	248	58.2	306
7					279	47.8	327	268	53.1	321	256	58.7	315	
8					287	48.3	335	277	53.6	331	265	59.3	325	
9					294	48.7	343	285	54.1	339	274	59.9	334	
10								293	54.6	347	282	60.4	343	
11								300	55.0	355	290	60.9	351	
12								308	55.5	364	298	61.4	359	
13								317	56.0	373	306	62.0	368	
14								325	56.5	381	314	62.5	376	
15								333	57.0	390	322	63.0	385	

NOTES

Cc (cooling capacity) - Pi (unit power input) - ELWT (Evaporator leaving water temperature - Δt 5°C) - Condenser Water temperature Δt 5°C
 Data refers to 0,0176m² °C/kW evaporator fouling factor
 Data refers to 0,0440m² °C/kW condenser fouling factor

CAPCOOL_1-2-3-4-5-6_Rev.00_1

6 Capacity tables

6 - 1 Cooling Capacity Tables

6

EWWD120~250J-SS

Unit	EWLT (°C)	Entering condenser water temp. (°C)												
		35			40			45			50			
		Cc (kW)	Pi (kW)	Hc (kW)	Cc (kW)	Pi (kW)	Hc (kW)	Cc (kW)	Pi (kW)	Hc (kW)	Cc (kW)	Pi (kW)	Hc (kW)	
120	4	103	29.0	132	98.1	31.9	130	92.5	35.1	128	86.7	38.6	125	
	5	107	29.3	136	102	32.3	134	95.9	35.4	131	90.0	38.9	129	
	6	111	29.6	140	105	32.6	138	99.5	35.7	135	93.3	39.2	133	
	7	115	30.0	145	109	32.9	142	103	36.1	139	96.7	39.5	136	
	8	119	30.3	149	113	33.2	146	107	36.4	143	100	39.9	140	
	9	123	30.6	153	117	33.6	150	111	36.8	147	104	40.2	144	
	10	127	31.0	158	121	33.9	155	114	37.1	152	108	40.6	148	
	11	131	31.3	162	125	34.2	159	118	37.5	156	112	40.9	152	
	12	135	31.6	166	129	34.6	163	122	37.8	160	115	41.3	157	
	13	139	32.0	171	133	35.0	168	126	38.2	165	119	41.7	161	
	14	143	32.3	175	137	35.3	172	131	38.6	169	123	42.0	165	
	15	147	32.7	180	141	35.7	177	135	38.9	173	127	42.4	170	
	140	4	125	35.5	161	118	39.0	157	111	42.9	154	104	47.1	151
		5	130	35.8	165	123	39.4	162	116	43.2	159	108	47.4	156
		6	134	36.2	170	127	39.7	167	120	43.6	164	112	47.8	160
7		139	36.5	175	132	40.1	172	125	44.0	169	117	48.2	165	
8		144	36.9	181	137	40.5	177	129	44.3	173	121	48.6	170	
9		149	37.3	186	142	40.8	182	134	44.7	178	126	48.9	175	
10		154	37.7	192	146	41.2	188	139	45.1	184	130	49.3	180	
11		159	38.1	197	152	41.6	193	143	45.5	189	135	49.8	185	
12		164	38.5	203	157	42.1	199	148	45.9	194	140	50.2	190	
13		170	38.9	209	162	42.5	204	154	46.4	200	145	50.6	195	
14		175	39.3	214	167	42.9	210	159	46.8	206	150	51.0	201	
15		180	39.7	220	172	43.3	216	164	47.3	211	155	51.5	206	
150		4	135	41.2	178	128	45.3	174	122	49.9	172	114	54.9	169
		5	140	41.6	181	133	45.7	178	126	50.3	176	118	55.3	174
		6	144	42.0	186	137	46.1	183	130	50.6	181	123	55.7	178
	7	149	42.3	191	142	46.4	188	135	51.0	186	127	56.1	183	
	8	154	42.7	196	147	46.8	194	139	51.4	191	131	56.5	188	
	9	158	43.1	201	151	47.2	199	144	51.8	196	136	56.9	193	
	10	163	43.4	206	156	47.6	204	149	52.2	201	140	57.3	198	
	11	168	43.8	211	161	48.0	209	153	52.6	206	145	57.8	203	
	12	173	44.2	217	165	48.4	214	158	53.0	211	150	58.2	208	
	13	177	44.6	222	170	48.8	219	163	53.4	216	155	58.6	213	
	14	182	45.0	227	175	49.2	224	167	53.9	221	159	59.1	218	
	15	187	45.4	233	180	49.6	230	172	54.3	227	164	59.5	223	
	180	4	155	47.4	202	147	52.2	199	140	57.5	197	131	63.1	194
		5	160	47.8	208	152	52.6	205	144	57.9	202	136	63.6	199
		6	165	48.2	214	157	53.0	210	149	58.3	207	141	64.1	205
7		171	48.7	220	163	53.5	216	154	58.7	213	146	64.5	210	
8		176	49.1	225	168	54.0	222	159	59.2	219	150	64.9	215	
9		182	49.6	231	174	54.4	228	165	59.7	225	155	65.4	221	
10		187	50.0	237	179	54.9	234	170	60.2	231	161	65.9	227	
11		193	50.5	244	185	55.3	240	176	60.7	237	166	66.4	233	
12		199	50.9	250	191	55.8	246	182	61.1	243	172	66.9	239	
13		205	51.4	256	196	56.3	253	187	61.6	249	177	67.4	245	
14		211	51.9	263	202	56.8	259	193	62.1	255	183	67.9	251	
15		217	52.4	269	208	57.3	265	199	62.7	261	189	68.5	257	
210		4	181	52.7	233	172	58.2	230	161	64.3	225	148	71.5	219
		5	187	53.2	240	178	58.6	236	167	64.8	232	153	72.0	225
		6	193	53.7	247	184	59.1	243	173	65.3	238	159	72.5	232
	7	200	54.2	254	190	59.6	249	178	65.8	244	165	73.0	238	
	8	206	54.6	260	196	60.1	256	184	66.3	251	171	73.6	245	
	9	212	55.1	267	202	60.6	263	191	66.8	257	177	74.1	251	
	10	218	55.6	274	209	61.1	270	197	67.4	264	182	74.6	257	
	11	225	56.1	281	215	61.6	277	203	67.9	271	188	75.2	264	
	12	231	56.6	288	221	62.1	283	209	68.4	278	195	75.8	271	
	13	238	57.1	295	228	62.6	290	216	69.0	285	201	76.4	278	
	14	245	57.6	302	234	63.2	298	222	69.6	292	207	76.9	284	
	15	252	58.2	310	241	63.7	305	228	70.1	299	213	77.5	291	
	250	4	223	63.4	286	211	70.2	282	200	77.7	277	187	86.1	273
		5	230	63.9	294	219	70.7	290	207	78.2	285	194	86.5	281
		6	237	64.3	301	226	71.2	298	214	78.7	293	201	87.0	288
7		245	64.9	309	233	71.7	305	222	79.2	301	209	87.5	296	
8		253	65.5	318	240	72.2	313	229	79.7	309	216	88.0	304	
9		262	66.0	328	249	72.8	322	236	80.2	316	224	88.5	312	
10		270	66.7	337	257	73.4	331	243	80.8	324	231	89.0	320	
11		279	67.3	346	266	74.0	340	252	81.4	333	238	89.5	327	
12		287	67.8	355	275	74.7	350	260	82.1	343	246	90.1	336	
13		295	68.3	363	283	75.3	358	269	82.7	352	254	90.8	345	
14		303	68.9	371	291	75.8	366	278	83.4	361	263	91.5	354	
15		310	69.5	380	298	76.4	375	286	84.0	370	271	92.2	364	

NOTES

Cc (cooling capacity) - Pi (unit power input) - ELWT (Evaporator leaving water temperature - Δt 5°C) - Condenser Water temperature Δt 5°C
 Data refers to 0,0176m² °C/kW evaporator fouling factor
 Data refers to 0,0440m² °C/kW condenser fouling factor

CAPCOOL_1-2-3-4-5-6_Rev.00_2

6 Capacity tables

6 - 1 Cooling Capacity Tables

EWWD280-400J-SS

Unit	EWLT (°C)	Entering condenser water temp. (°C)												
		15			20			25			30			
		Cc(kW)	Pi(kW)	Hc(kW)	Cc(kW)	Pi(kW)	Hc(kW)	Cc(kW)	Pi(kW)	Hc(kW)	Cc(kW)	Pi(kW)	Hc(kW)	
280	4				281	56.0	337	271	60.5	331	259	65.7	324	
	5				289	56.8	346	280	61.4	341	268	66.6	334	
	6				297	57.6	355	287	62.2	350	277	67.5	345	
	7				305	58.5	364	295	63.0	358	285	68.3	353	
	8				314	59.3	373	304	63.9	367	293	69.1	362	
	9				322	60.2	382	312	64.7	376	301	69.9	371	
	10							320	65.6	386	309	70.8	380	
	11							328	66.5	395	317	71.6	389	
	12							337	67.4	404	326	72.5	398	
	13							346	68.4	414	334	73.5	408	
	14							354	69.3	424	343	74.4	417	
	15							363	70.3	433	351	75.3	427	
	310	4				305	61.6	367	294	68.2	363	282	75.0	357
		5				314	62.2	377	304	68.8	372	292	75.8	368
		6				324	62.8	386	313	69.4	382	301	76.4	378
7					333	63.4	397	322	70.0	392	310	77.0	387	
8					343	64.2	407	331	70.8	402	320	77.8	398	
9					352	64.8	417	341	71.4	413	329	78.6	408	
10								351	72.2	423	339	79.2	418	
11								361	73.0	434	349	80.0	429	
12								371	73.6	445	358	80.8	439	
13								381	74.4	456	368	81.6	450	
14								392	75.2	467	379	82.2	461	
15								402	76.0	478	389	83.2	472	
330		4				328	66.0	394	316	73.0	389	303	80.5	384
		5				338	66.7	404	326	73.8	400	313	81.3	395
		6				348	67.4	415	336	74.5	411	324	82.0	406
	7				358	68.1	426	346	75.2	421	334	82.7	416	
	8				369	68.9	438	357	76.0	433	344	83.6	427	
	9				380	69.7	449	367	76.7	444	354	84.4	439	
	10							378	77.5	456	365	85.1	450	
	11							389	78.4	467	375	86.0	461	
	12							400	79.1	479	386	86.9	473	
	13							411	80.0	491	397	87.7	485	
	14							423	80.9	504	408	88.5	497	
	15							434	81.7	516	420	89.5	509	
	360	4				350	70.4	421	337	77.8	415	324	86.0	410
		5				361	71.2	432	349	78.8	427	335	86.8	421
		6				372	72.0	444	359	79.6	439	346	87.6	433
7					384	72.8	456	371	80.4	451	357	88.4	445	
8					395	73.6	469	382	81.2	463	368	89.4	457	
9					407	74.6	481	393	82.0	475	379	90.2	469	
10								405	82.8	488	390	91.0	481	
11								417	83.8	501	402	92.0	494	
12								429	84.6	513	414	93.0	507	
13								441	85.6	527	426	93.8	520	
14								454	86.6	540	438	94.8	533	
15								466	87.4	554	451	95.8	546	
380		4				380	74.4	454	366	82.4	448	351	90.9	442
		5				392	75.2	467	377	83.3	461	362	91.8	454
		6				403	76.0	479	389	84.2	473	375	92.7	467
	7				416	76.9	492	401	85.0	486	386	93.5	480	
	8				428	77.7	505	413	85.9	499	398	94.5	492	
	9				440	78.7	519	425	86.7	512	410	95.3	505	
	10							438	87.6	525	422	96.2	518	
	11							450	88.6	539	435	97.2	532	
	12							463	89.5	553	447	98.2	545	
	13							476	90.5	567	460	99.1	559	
	14							490	91.5	581	473	100	573	
	15							503	92.4	595	486	101	587	
	400	4				410	78.4	488	394	87.0	481	378	95.8	474
		5				422	79.2	501	406	87.8	494	390	96.8	487
		6				435	80.0	515	419	88.8	507	403	97.8	501
7					447	81.0	528	431	89.6	521	416	98.6	514	
8					460	81.8	542	444	90.6	535	428	99.6	528	
9					474	82.8	557	457	91.4	549	441	100	541	
10								471	92.4	563	454	101	555	
11								484	93.4	577	467	102	570	
12								497	94.4	592	481	103	584	
13								511	95.4	607	494	104	599	
14								526	96.4	622	508	105	613	
15								540	97.4	637	522	106	628	

NOTES

Cc (cooling capacity) - Pi (unit power input) - ELWT (Evaporator leaving water temperature - Δt 5°C) - Condenser Water temperature Δt 5°C
 Data refers to 0,0176m² °C/kW evaporator fouling factor
 Data refers to 0,0440m² °C/kW condenser fouling factor

CAPCOOL_1-2-3-4-5-6_Rev.00_3

6 Capacity tables

6 - 1 Cooling Capacity Tables

6

EWWD280~400J-SS

Unit	EWT (°C)	Entering condenser water temp. (°C)												
		35			40			45			50			
		Cc (kW)	Pi (kW)	Hc (kW)	Cc (kW)	Pi (kW)	Hc (kW)	Cc (kW)	Pi (kW)	Hc (kW)	Cc (kW)	Pi (kW)	Hc (kW)	
280	4	248	71.6	318	235	78.4	313	223	86.1	309	209	94.5	304	
	5	255	72.4	328	242	79.1	321	230	86.7	317	217	95.2	312	
	6	264	73.3	337	251	79.9	331	237	87.4	325	225	95.9	321	
	7	273	74.2	348	260	80.8	340	245	88.1	333	232	96.6	329	
	8	282	75.1	357	269	81.6	350	254	89.0	343	239	97.2	336	
	9	290	75.9	366	278	82.6	360	263	89.9	353	248	98.0	346	
	10	298	76.7	374	286	83.4	369	272	90.8	363	256	98.9	355	
	11	306	77.5	383	294	84.2	378	281	91.6	372	265	99.8	365	
	12	314	78.4	392	302	85.0	387	289	92.5	381	274	101	375	
	13	322	79.3	402	310	85.9	396	297	93.3	390	283	102	384	
	14	331	80.2	411	318	86.7	405	305	94.1	399	290	102	393	
	15	339	81.1	420	326	87.7	414	313	95.0	408	298	103	402	
	310	4	270	82.4	352	257	90.6	347	243	99.8	343	228	110	337
		5	279	83.2	362	266	91.4	357	252	101	352	236	111	347
		6	289	84.0	373	275	92.2	367	260	101	361	245	111	357
7		298	84.6	383	284	92.8	377	269	102	371	254	112	366	
8		307	85.4	393	294	93.6	387	278	103	381	262	113	375	
9		316	86.2	403	303	94.4	397	288	104	391	271	114	385	
10		326	86.8	413	312	95.2	407	297	104	402	281	115	395	
11		335	87.6	423	321	96.0	417	307	105	412	290	116	406	
12		345	88.4	433	331	96.8	428	316	106	422	300	116	416	
13		355	89.2	444	341	97.6	438	325	107	432	309	117	426	
14		365	90.0	455	350	98.4	449	335	108	443	318	118	436	
15		375	90.8	466	360	99.2	459	345	109	453	328	119	447	
330		4	289	88.6	378	276	97.5	373	261	107	369	245	118	363
		5	299	89.4	389	285	98.3	383	270	108	378	254	119	373
		6	310	90.2	400	295	99.1	394	279	109	388	263	120	383
	7	320	91.0	411	305	99.9	405	289	110	398	272	121	393	
	8	330	91.8	422	315	101	416	298	111	409	281	121	403	
	9	340	92.7	433	325	102	427	309	112	420	291	122	413	
	10	350	93.4	444	335	103	438	319	112	432	301	123	424	
	11	361	94.3	455	346	103	449	329	113	443	311	124	436	
	12	372	95.1	467	356	104	460	339	114	454	322	125	447	
	13	382	96.0	478	367	105	472	350	115	465	332	126	458	
	14	393	96.9	490	377	106	483	360	116	476	342	127	469	
	15	404	97.8	502	388	107	495	371	117	488	353	128	481	
	360	4	309	94.8	404	295	104	399	279	115	394	261	126	388
		5	320	95.6	415	304	105	409	289	116	405	271	127	399
		6	331	96.4	427	315	106	421	298	117	415	281	128	410
7		342	97.4	439	325	107	432	308	117	425	291	129	420	
8		353	98.2	451	337	108	445	319	118	437	301	130	430	
9		364	99.2	463	348	109	457	330	119	449	311	131	441	
10		375	100	475	359	110	468	341	120	461	322	132	453	
11		386	101	487	370	111	480	352	121	473	333	133	465	
12		398	102	500	381	112	493	363	122	485	344	134	478	
13		410	103	513	393	113	505	374	123	498	355	135	490	
14		422	104	525	404	114	518	386	124	510	366	136	502	
15		434	105	539	416	115	531	397	125	523	377	137	514	
380		4	335	100	435	319	110	430	301	122	423	278	135	413
		5	347	101	448	330	111	441	312	123	434	289	136	425
		6	358	102	460	341	112	453	322	124	446	300	137	437
	7	370	103	473	353	113	466	332	125	457	311	138	448	
	8	382	104	486	364	114	479	344	126	469	321	139	460	
	9	394	105	499	376	115	491	356	127	482	332	140	471	
	10	406	106	511	388	116	504	367	128	495	343	141	484	
	11	418	107	525	400	117	517	379	129	508	355	142	496	
	12	430	108	538	412	118	530	391	130	520	367	143	509	
	13	443	109	551	424	119	543	403	131	533	379	144	522	
	14	456	110	565	436	120	556	415	132	547	390	145	535	
	15	469	111	579	449	121	570	427	133	560	402	146	548	
	400	4	362	105	467	344	116	460	322	129	451	295	143	438
		5	374	106	480	355	117	473	334	130	464	307	144	451
		6	386	107	494	367	118	485	346	131	476	318	145	463
7		399	108	507	380	119	499	357	132	489	330	146	476	
8		412	109	521	392	120	512	369	133	502	342	147	489	
9		424	110	534	405	121	526	381	134	515	353	148	501	
10		437	111	548	417	122	540	394	135	529	365	149	514	
11		450	112	562	430	123	553	406	136	542	377	150	527	
12		463	113	576	443	124	567	419	137	556	390	152	541	
13		476	114	590	455	125	581	431	138	569	402	153	555	
14		490	115	605	469	126	595	444	139	583	414	154	568	
15		503	116	620	482	127	609	457	140	597	427	155	582	

NOTES

Cc (cooling capacity) - Pi (unit power input) - ELWT (Evaporator leaving water temperature - Δt 5°C) - Condenser Water temperature Δt 5°C
 Data refers to 0,0176m² °C/kW evaporator fouling factor
 Data refers to 0,0440m² °C/kW condenser fouling factor

CAPCOOL_1-2-3-4-5-6_Rev.00_4

6 Capacity tables

6 - 1 Cooling Capacity Tables

EWWD450-560J-SS

Unit	EWLT (°C)	Entering condenser water temp. (°C)												
		15			20			25			30			
		Cc (kW)	Pi (kW)	Hc (kW)	Cc (kW)	Pi (kW)	Hc (kW)	Cc (kW)	Pi (kW)	Hc (kW)	Cc (kW)	Pi (kW)	Hc (kW)	
450	4				457	85.6	543	439	95.0	534	421	105	527	
	5				472	86.5	559	454	95.9	550	435	106	541	
	6				487	87.4	575	468	97.0	565	449	107	557	
	7				503	88.3	591	484	97.9	581	464	108	572	
	8				517	89.2	606	499	98.9	598	479	109	588	
	9				531	90.1	621	513	100	613	495	110	605	
	10							528	101	629	509	111	620	
	11							542	102	644	524	112	636	
	12							557	103	660	538	113	651	
	13							572	104	676	553	114	667	
	14							587	105	692	568	115	683	
	15							603	106	709	583	116	699	
	500	4				505	92.8	598	484	103	587	465	114	580
		5				522	93.8	616	501	104	605	479	115	594
		6				540	94.8	635	518	105	623	496	116	612
7					558	95.6	653	536	106	642	513	117	630	
8					573	96.6	670	554	107	661	530	119	649	
9					589	97.4	686	570	108	678	548	120	668	
10								585	109	694	565	121	685	
11								601	110	711	580	122	702	
12								617	111	728	596	123	719	
13								633	112	745	612	124	736	
14								649	113	762	628	125	753	
15								666	114	780	644	126	770	
530		4				534	102	636	513	112	625	491	123	614
		5				550	104	654	530	113	643	507	124	631
		6				567	105	672	547	115	661	525	126	651
	7				584	106	690	563	116	679	541	127	668	
	8				600	108	708	581	118	698	558	128	687	
	9				616	109	725	598	119	715	575	130	705	
	10							613	120	733	591	131	723	
	11							629	122	750	607	133	740	
	12							645	123	768	624	134	757	
	13							662	124	786	640	136	776	
	14							679	126	805	657	137	794	
	15							696	127	823	673	138	812	
	560	4				563	112	675	541	121	662	517	131	649
		5				578	114	692	559	123	682	536	133	669
		6				594	115	710	575	124	699	554	135	689
7					611	117	728	591	126	717	570	137	707	
8					627	119	746	607	128	735	586	138	724	
9					644	120	764	623	129	753	602	140	742	
10								640	131	771	618	142	760	
11								657	133	790	635	143	778	
12								674	135	809	651	145	796	
13								691	137	828	668	147	815	
14								709	139	847	686	149	834	
15								726	141	867	703	151	853	

NOTES

Cc (cooling capacity) - Pi (unit power input) - ELWT (Evaporator leaving water temperature - Δt 5°C) - Condenser Water temperature Δt 5°C
 Data refers to 0,0176m² °C/kW evaporator fouling factor
 Data refers to 0,0440m² °C/kW condenser fouling factor

CAPCOOL_1-2-3-4-5-6_Rev.00_5

6 Capacity tables

6 - 1 Cooling Capacity Tables

6

EWWD450~560J-SS

Unit	EWLT (°C)	Entering condenser water temp. (°C)												
		35			40			45			50			
		Cc (kW)	Pi (kW)	Hc (kW)	Cc (kW)	Pi (kW)	Hc (kW)	Cc (kW)	Pi (kW)	Hc (kW)	Cc (kW)	Pi (kW)	Hc (kW)	
450	4	404	116	520	383	128	512	361	142	503	335	158	492	
	5	417	117	534	397	129	526	374	143	517	348	159	506	
	6	430	118	548	410	130	540	387	144	531	361	160	520	
	7	444	119	563	423	131	554	400	145	545	374	161	534	
	8	459	120	579	437	132	569	414	146	560	387	162	549	
	9	474	121	595	451	133	585	427	147	574	400	163	563	
	10	489	122	611	466	135	600	440	148	589	413	164	577	
	11	504	123	627	481	136	617	455	149	604	426	165	591	
	12	518	124	643	496	137	633	470	151	620	440	166	606	
	13	533	125	658	511	138	649	485	152	637	455	167	622	
	14	547	127	674	525	139	664	500	153	653	470	168	638	
	15	562	128	690	539	140	679	514	154	668	485	170	654	
	500	4	446	127	572	423	140	563	399	155	554	374	172	546
		5	460	128	587	438	141	579	413	156	570	388	173	561
		6	473	129	602	453	142	595	428	157	586	403	174	577
7		489	130	619	467	143	610	444	158	602	417	175	592	
8		506	131	637	481	144	625	458	159	618	432	176	608	
9		523	132	655	497	146	643	472	160	632	448	177	625	
10		541	133	674	514	147	661	487	162	649	461	178	639	
11		558	135	693	532	148	680	504	163	667	475	179	654	
12		574	136	709	550	149	699	521	164	685	491	180	671	
13		589	137	726	566	151	716	538	165	704	508	182	690	
14		605	138	743	581	152	733	556	167	723	525	183	708	
15		621	139	760	597	153	750	571	168	739	543	184	727	
530		4	469	135	604	446	149	594	423	164	586	396	181	577
		5	485	136	621	461	150	611	437	165	602	411	182	593
		6	501	138	638	477	151	628	452	166	618	426	183	609
	7	518	139	657	493	153	645	467	167	635	441	184	625	
	8	535	141	675	509	154	663	483	169	652	455	185	640	
	9	551	142	693	527	155	682	499	170	669	471	187	658	
	10	568	143	712	543	157	700	516	172	687	487	188	675	
	11	585	145	730	559	158	718	533	173	706	503	189	692	
	12	601	146	747	576	160	736	549	175	724	520	191	711	
	13	617	148	764	593	161	754	566	176	742	537	192	729	
	14	633	149	782	609	163	771	583	178	760	553	194	747	
	15	650	151	800	625	164	789	598	179	777	570	196	765	
	560	4	493	143	636	469	157	626	446	172	618	418	189	607
		5	510	145	655	484	158	643	460	173	634	434	190	624
		6	528	147	675	502	160	661	475	175	649	450	192	642
7		547	148	695	519	162	681	491	176	667	464	193	657	
8		564	150	714	537	163	700	508	178	686	478	194	673	
9		579	152	731	556	165	721	526	180	706	495	196	691	
10		595	153	749	571	167	738	544	182	726	513	198	710	
11		612	155	767	587	168	756	562	183	745	530	200	730	
12		628	157	785	603	170	773	577	185	762	549	201	750	
13		645	159	803	619	172	791	593	187	780	565	203	768	
14		661	160	822	636	173	809	609	188	797	581	205	786	
15		678	162	841	653	175	828	625	190	815	597	207	803	

NOTES

Cc (cooling capacity) - Pi (unit power input) - ELWT (Evaporator leaving water temperature - Δt 5°C) - Condenser Water temperature Δt 5°C
 Data refers to 0,0176m² °C/kW evaporator fouling factor
 Data refers to 0,0440m² °C/kW condenser fouling factor

7 Pressure drops

7 - 1 Evaporator Pressure Drops

Evaporator and Condenser Pressure Drops

EWWD-J-SS

	120	140	150	180	210	250	280	310	330	360
Cooling capacity (kW)	120	146	155	178	208	256	285	310	334	357
Water flow (l/s) - Evaporator	5.73	6.98	7.41	8.50	9.94	12.25	13.63	14.81	15.96	17.06
Evaporator Pressure Drops (kPa)	15	13	40	38	36	28	33	40	40	38
Water flow (l/s) - Condenser	7.04	8.57	9.25	10.62	12.30	15.06	16.89	18.49	19.91	21.28
Condenser Pressure Drops (kPa)	20	12	11	11	11	16	26	11	11	11

NOTES

Water flow and pressure drop referred to nominal condition: evaporator water in/out: 12/7°C - condenser water in/out: 30/35°C

	380	400	450	500	530	560
Cooling capacity (kW)	386	416	464	513	541	570
Water flow (l/s) - Evaporator	18.44	19.88	22.17	24.51	25.85	27.23
Evaporator Pressure Drops (kPa)	38	36	36	28	28	33
Water flow (l/s) - Condenser	23.15	24.59	27.33	30.10	31.92	33.78
Condenser Pressure Drops (kPa)	11	11	11	16	16	26

NOTES

Water flow and pressure drop referred to nominal condition: evaporator water in/out: 12/7°C - condenser water in/out: 30/35°C

Evaporator and Condenser Pressure Drops

To determinate the evaporator or condenser pressure drop for different versions or at different working condition, please refer to the following formula:

$$PD_2 \text{ (kPa)} = PD_1 \text{ (kPa)} \times \left(\frac{Q_2 \text{ (l/s)}}{Q_1 \text{ (l/s)}} \right)^{1.8}$$

where:

PD₂	Pressure drop to be determinated (kPa)
PD₁	Pressure drop at nominal condition (kPa)
Q₂	water flow at new working condition (l/s)
Q₁	water flow at nominal condition (l/s)

How to use the fomula: Example (Evaporator)

The unit EWWD280J-SS has been selected for working at the following conditions:

- evaporator water in/out: 11/6°C
- condenser water in/out: 30/35°C

The cooling capacity at these working conditions is: 277 kW

The evaporator water flow at these working conditions is: 13.23 l/s

The unit EWWD280J-SS at nominal working conditions has the following data:

- evaporator water in/out: 12/7°C
- condenser water in/out: 30/35°C

The cooling capacity at these working conditions is: 285 kW

The evaporator water flow at these working conditions is: 13.62 l/s

The evaporator pressure drop at these working conditions is: 33 kPa

The evaporator pressure drop at the selected working condition will be:

$$PD_2 \text{ (kPa)} = 33 \text{ (kPa)} \times \left(\frac{13.23 \text{ (l/s)}}{13.62 \text{ (l/s)}} \right)^{1.8}$$

$$PD_2 \text{ (kPa)} = 31 \text{ (kPa)}$$

Note: If the calculated evaporator water pressure drop is below 10 kPa or above 100 kPa please contact the factory for dedicated evaporator..

8 Dimensional drawings

8 - 1 Dimensional Drawings

8

EWWD-J-SS / 1 circuit

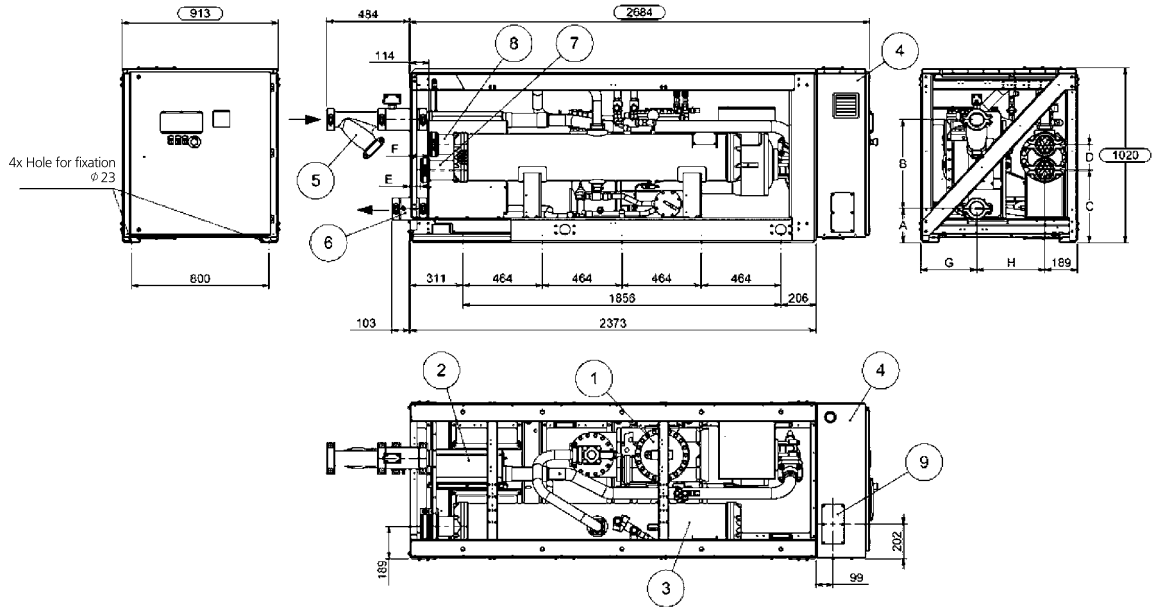

Models	Dimensions (mm)							
EWWD-J-SS	A	B	C	D	E	F	G	H
120	198	519	445	115	54	104	326	398
140	198	519	422	150	64	114	326	398
150	198	568	422	150	64	114	311	413
180	198	568	422	150	64	114	311	413
210	198	568	422	150	64	114	311	413
250	198	568	422	150	64	114	311	413
280	198	568	422	150	64	114	311	413

Legend

- 1 Compressor
- 2 Evaporator
- 3 Condenser
- 4 Electrical panel
- 5 Evaporator water inlet
- 6 Evaporator water outlet
- 7 Condenser water inlet connection
- 8 Condenser water outlet connection
- 9 Power connections slot

DMN_1-2_Rev.00_1

8 Dimensional drawings

8 - 1 Dimensional Drawings

EWWD~J-SS / 2 Circuits

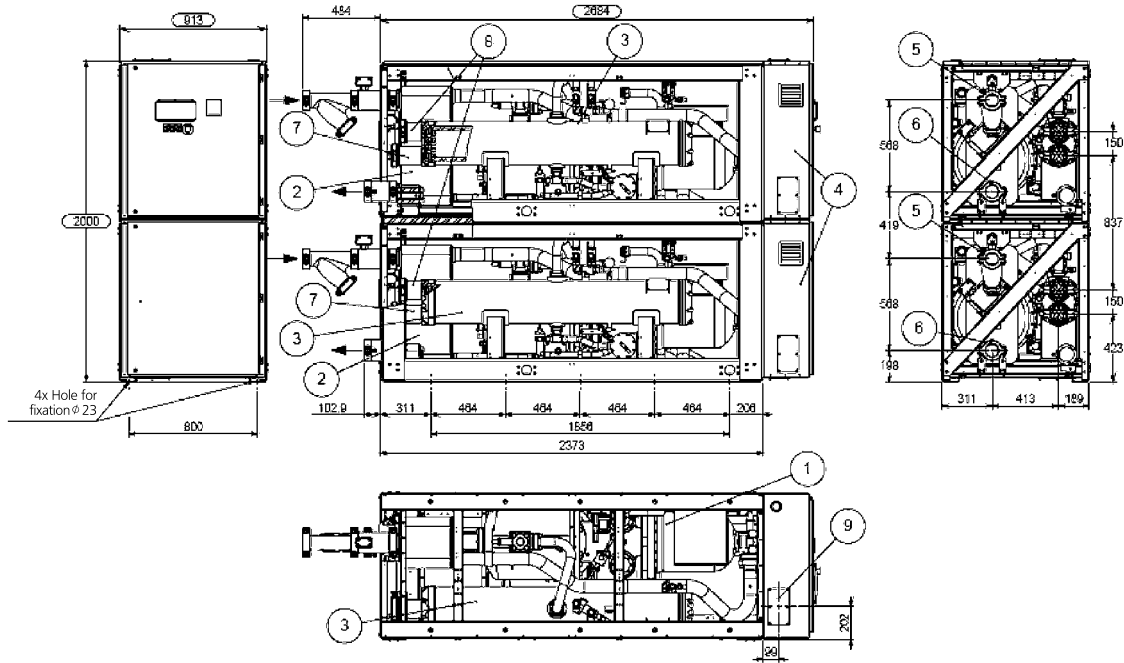

Note: Dimension refers to 2 circuit units (size from 310-560).

Legend

- 1 Compressor
- 2 Evaporator
- 3 Condenser
- 4 Electrical panel
- 5 Evaporator water inlet
- 6 Evaporator water outlet
- 7 Condenser water inlet connection
- 8 Condenser water outlet connection
- 9 Power connections slot

DMN_1-2_Rev.00_2

9 Sound data

9 - 1 Sound Level Data

Sound levels

EWWD-J-SS

Unit size	Sound pressure level at 1 m from the unit in semispheric free field (ref. 2×10^{-5} Pa)									power dB(A)
	63 Hz	125 Hz	250 Hz	500 Hz	1000 Hz	2000 Hz	4000 Hz	8000 Hz	dB(A)	
120	57.0	61.5	66.5	70.9	66.0	63.6	51.0	48.1	71.4	88.6
140	57.0	61.5	66.5	70.9	66.0	63.6	51.0	48.1	71.4	88.6
150	57.0	61.5	66.5	70.9	66.0	63.6	51.0	48.1	71.4	88.6
180	57.0	61.5	66.5	70.9	66.0	63.6	51.0	48.1	71.4	88.6
210	57.0	61.5	66.5	70.9	66.0	63.6	51.0	48.1	71.4	88.6
250	58.3	58.3	63.8	68.8	63.3	64.3	53.3	49.8	70.0	87.2
280	58.3	58.3	63.8	68.8	63.3	64.3	53.3	49.8	70.0	87.2
310	60.0	64.5	69.5	73.9	69.0	66.6	54.0	51.1	74.4	92.4
330	60.0	64.5	69.5	73.9	69.0	66.6	54.0	51.1	74.4	92.4
360	60.0	64.5	69.5	73.9	69.0	66.6	54.0	51.1	74.4	92.4
380	60.0	64.5	69.5	73.9	69.0	66.6	54.0	51.1	74.4	92.4
400	60.0	64.5	69.5	73.9	69.0	66.6	54.0	51.1	74.4	92.4
450	60.7	63.2	68.4	73.0	67.9	67.0	55.3	52.0	73.8	91.8
500	61.3	61.3	66.8	71.8	66.3	67.3	56.3	52.8	73.0	91.0
530	61.3	61.3	66.8	71.8	66.3	67.3	56.3	52.8	73.0	91.0
560	61.3	61.3	66.8	71.8	66.3	67.3	56.3	52.8	73.0	91.0

NOTES

- 1 The values are according to ISO 3744 and are referred to: evaporator 12/7° C, condenser 30/35° C, full load operation.
- 2 The above sound pressure levels will decrease by 4dB(A) when a compressor sound enclosure (option) is installed.

Sound pressure level correction factor for different distances

Unit size	Distance					
	1 m	5 m	10 m	15 m	20 m	25 m
120	0.0	-7.9	-12.7	-15.8	-18.1	-19.8
140	0.0	-7.9	-12.7	-15.8	-18.1	-19.8
150	0.0	-7.9	-12.7	-15.8	-18.1	-19.8
180	0.0	-7.9	-12.7	-15.8	-18.1	-19.8
210	0.0	-7.9	-12.7	-15.8	-18.1	-19.8
250	0.0	-7.5	-12.2	-15.3	-17.5	-19.3
280	0.0	-7.9	-12.7	-15.8	-18.1	-19.8
310	0.0	-7.5	-12.2	-15.3	-17.5	-19.3
330	0.0	-7.5	-12.2	-15.3	-17.5	-19.3
360	0.0	-7.9	-12.7	-15.8	-18.1	-19.8
380	0.0	-7.5	-12.2	-15.3	-17.5	-19.3
400	0.0	-7.5	-12.2	-15.3	-17.5	-19.3
450	0.0	-7.5	-12.2	-15.3	-17.5	-19.3
500	0.0	-7.5	-12.2	-15.3	-17.5	-19.3
530	0.0	-7.5	-12.2	-15.3	-17.5	-19.3
560	0.0	-7.5	-12.2	-15.3	-17.5	-19.3

NOTES

- 1 The values are dB(A) (pressure level).

NSL_1_Rev.00_1

10 Installation

10 - 1 Installation Method

Installation notes

Warning

Installation and maintenance are to be performed only by qualified personnel who are familiar with local codes and regulations, and who are experienced with this type of equipment. Must be avoided the unit installation in places that could be considered dangerous for all the maintenance operations.

Handling

The chiller is mounted on heavy wooden skids to protect the unit from accidental damage and to permit easy handling and moving. It is recommended that all moving and handling be performed with the skids under the unit when possible and that the skids not be removed until the unit is in the final location.

If the unit must be hoisted, it is necessary to lift the unit by attaching cables or chains at the lifting holes in the evaporator tube sheets. Spreader bars must be used to protect the control cabinet and the other areas of the chiller.

Location

A levelled and sufficiently strong floor is required. If necessary, additional structural members should be provided to transfer the weight of the unit to the nearest beams.

Rubber-in-shear isolators are furnished and field placed under each corner of the package. A rubber anti-skid pad should be used under isolators if hold-down bolts are not used. Vibration isolator in all water piping connected to the chiller are recommended to avoid straining the piping and transmitting vibration and noise.

Minimum space requirements

Every side of the machine must be accessible for all post-installation maintenance activities. The minimum space required is shown on the following drawing

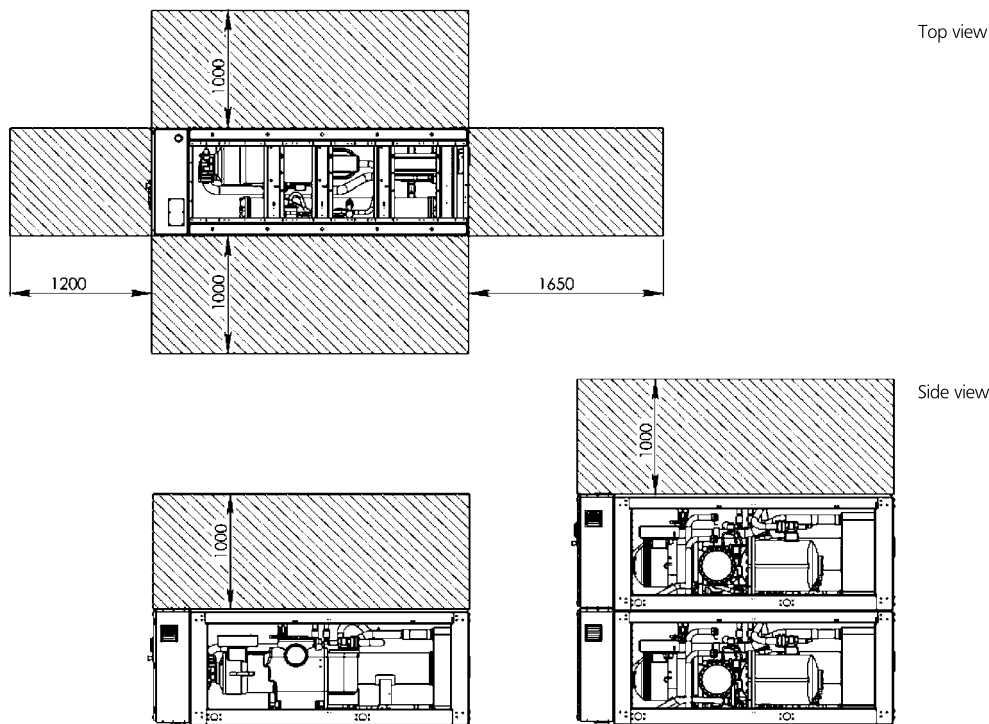

Minimum clearance requirements for machine maintenance

INN_1_Rev.00_1

10 Installation

10 - 2 Water Charge, Flow and Quality

Water charge, flow and quality

ITEMS ⁽¹⁾ (5)		Cooling water		Cooled water		Heated water ⁽²⁾				Tendency if out of criteria		
		Circulating system		Once flow	Circulating water (Below 20°C)		Low temperature		High temperature			
		Circulating water	Supply water ⁽⁴⁾	Flowing water			Circulating water (20°C ~ 50°C)	Supply water ⁽⁴⁾	Circulating water (80°C ~ 80°C)		Supply water ⁽⁴⁾	
Items to be controlled:	ph	at 25°C	6.5 - 8.2	6.0 - 8.0	6.0 - 8.0	6.8 - 8.0	6.0 - 8.0	7.0 - 8.0	7.0 - 8.0	7.0 - 8.0	7.0 - 8.0	Corrosion+Scale
	Electrical conductivity	(mS/m) at 25°C	Below 80	Below 30	Below 40	Below 80	Below 80	Below 30	Below 30	Below 30	Below 30	Corrosion+Scale
		(µS/cm) at 25°C	(Below 800)	(Below 300)	(Below 400)	(Below 800)	(Below 800)	(Below 300)	(Below 300)	(Below 300)	(Below 300)	Corrosion+Scale
	Chloride ion	[mgCl ⁻² /l]	Below 200	Below 50	Below 50	Below 200	Below 50	Below 50	Below 50	Below 50	Below 50	Corrosion
	Sulfate ion	[mgSO ²⁻⁴ /l]	Below 200	Below 50	Below 50	Below 200	Below 50	Below 50	Below 50	Below 50	Below 50	Corrosion
	Alkalinity (pH 8)	[mgCaCO ₃ /l]	Below 100	Below 50	Below 50	Below 100	Below 50	Below 50	Below 50	Below 50	Below 50	Scale
	Total hardness	[mgCaCO ₃ /l]	Below 200	Below 70	Below 70	Below 200	Below 70	Below 70	Below 70	Below 70	Below 70	Scale
	Calcium hardness	[mgCaCO ₃ /l]	Below 150	Below 50	Below 50	Below 50	Below 50	Below 50	Below 50	Below 50	Below 50	Scale
	Silica ion	[mgSiO ₂ /l]	Below 50	Below 30	Below 30	Below 30	Below 30	Below 30	Below 30	Below 30	Below 30	Scale
	Oxygen	[mgO ₂ /l]	Below 1.0	Below 1.0	Below 1.0	Below 1.0	Below 1.0	Below 1.0	Below 1.0	Below 1.0	Below 1.0	Corrosion
	Particle size	(mm)	Below 0.5	Below 0.5	Below 0.5	Below 0.5	Below 0.6	Below 0.5	Below 0.6	Below 0.5	Below 0.6	Erosion
	Total dissolved solids	(mg/l)	Below 1000	Below 1000	Below 1000	Below 1000	Below 1001	Below 1000	Below 1001	Below 1000	Below 1001	Erosion
	Ethylene Glycol (weight conc.)		Below 60%	Below 60%	Below ---	Below 60%	Below 60%	Below 60%	Below 60%	Below 60%	Below 60%	---
Items to be referred to:	Nitrate ion	(mg NO ₃ -N/l)	Below 100	Below 100	Below 100	Below 100	Below 101	Below 100	Below 101	Below 100	Below 101	Corrosion
	TOC Total organic carbon	(mg/l)	Below 1.0	Below 1.0	Below 1.0	Below 1.0	Below 1.0	Below 1.0	Below 1.0	Below 1.0	Below 1.0	Scale
	Iron	[mgFe/l]	Below 1.0	Below 0.3	Below 1.0	Below 1.0	Below 0.3	Below 1.0	Below 0.3	Below 1.0	Below 0.3	Corrosion+Scale
	Copper	[mgCu/l]	Below 0.3	Below 0.1	Below 1.0	Below 1.0	Below 1.0	Below 1.0	Below 0.1	Below 1.0	Below 0.1	Corrosion
	Sulfite ion	[mgS ²⁻ /l]	Not detectable	Not detectable	Not detectable	Not detectable	Not detectable	Not detectable	Not detectable	Not detectable	Not detectable	Corrosion
	Ammonium ion	[mgNH ⁺ ₄ /l]	Below 1.0	Below 0.1	Below 1.0	Below 1.0	Below 0.1	Below 0.3	Below 0.1	Below 0.1	Below 0.1	Corrosion
	Remaining chloride	[mgCl/l]	Below 0.3	Below 0.3	Below 0.3	Below 0.3	Below 0.3	Below 0.25	Below 0.3	Below 0.1	Below 0.3	Corrosion
	Free carbide	[mgC ₂ /l]	Below 4.0	Below 4.0	Below 4.0	Below 4.0	Below 4.0	Below 0.4	Below 4.0	Below 0.4	Below 4.0	Corrosion
	Stability index		6.0 - 7.0	---	---	---	---	---	---	---	---	Corrosion + Scale

NOTES

- Names, definitions and units are according to JIS K 0101. Units and figures between brackets are old units published as reference only.
- In case of using heated water (more than 40°C), corrosion is generally noticeable. Especially when the iron material is in direct contact with water without any protection shields, it is desirable to give the valid measures for corrosion. e.g. chemical measure.
- In the cooling water using hermetic cooling tower, closed circuit water is according to heated water standard, and scattered water is according to cooling water standard.
- Supply water is considered drink water, industrial water and ground water except for genuine water, neutral water and soft water.
- The above mentioned items are representable items in corrosion and scale cases.
- The limits above have to be considered as a general prescription and can not totally assure the absence of corrosion and erosion. Some particular combinations of elements or the presence of components not listed in the table or factors not considered may trigger corrosion phenomena.

WAFLOWQUA_1-2_Rev.00_1

10 Installation

10 - 2 Water Charge, Flow and Quality

Water content in cooling circuits

The cooled water distribution circuits should have a minimum water content to avoid excessive compressors starts and stops.

In fact, each time the compressor starts up, an excessive quantity of oil goes from the compressor's pump and simultaneously there is a rise in the temperature of the compressor motor's stator, due to the inrush current during the start-up.

To prevent damage to the compressors, it has been envisaged the application of a device to limit frequent stops and restarts.

During the span of one hour there will be no more than 6 starts of the compressor. The plant side should therefore ensure that the overall water content allows a more constant functioning of the unit and consequently greater environmental comfort. The minimum water content per unit should be calculated using this simplified formula:

For 1 compressor unit

$$M(\text{Liters}) = (0.94 \times \Delta T(^{\circ}\text{C}) + 5.87) \times P(\text{kW})$$

For 2 compressors unit

$$M(\text{Liters}) = (0.1595 \times \Delta T(^{\circ}\text{C}) + 3.0825) \times P(\text{kW})$$

where:

- M minimum water content per unit expressed in litres
- P Cooling Capacity of the unit expressed in kW
- ΔT evaporator entering / leaving water temperature difference expressed in $^{\circ}\text{C}$

This formula is valid for:

- standard microprocessor parameters

For more accurate determination of quantity of water, it is advisable to contact the designer of the plant.

WAFLOWQUA_1-2_Rev.00_2

11 Operation range

11 - 1 Operation Range

11

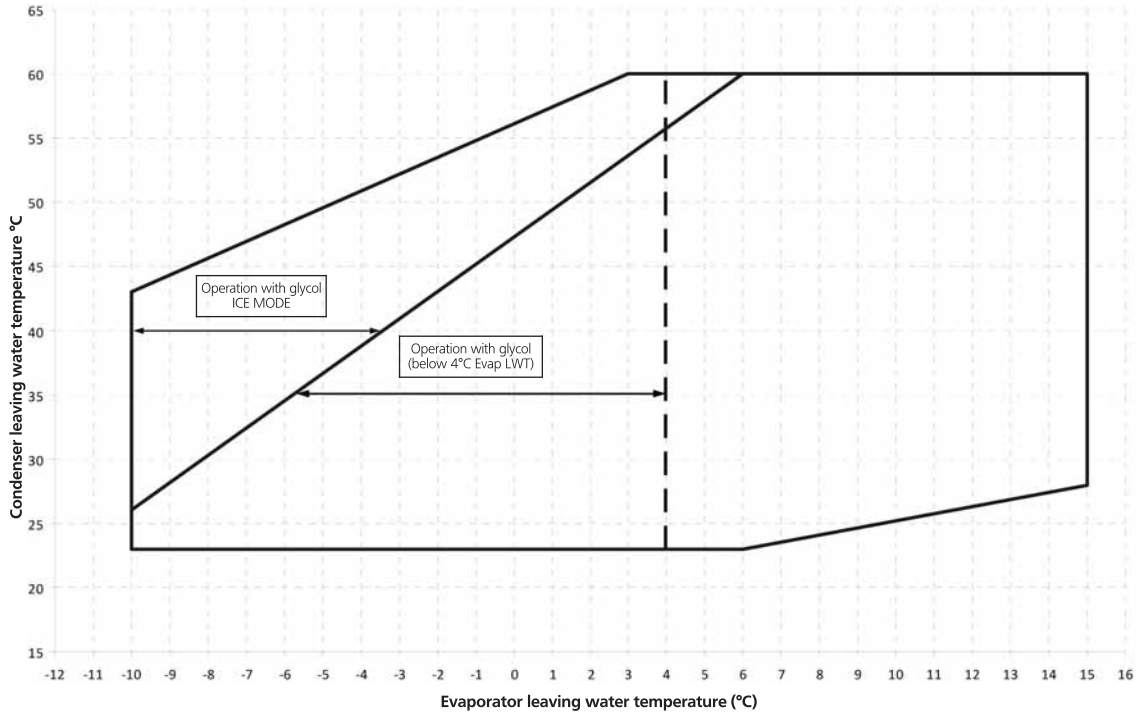

OPL_1-2-3_Rev.00_1

11 Operation range

11 - 1 Operation Range

Table 1 - Evaporator/Condenser minimum and maximum Δt

Max evaporator water ΔT	°C	8
Min evaporator water ΔT	°C	4
Min condenser water ΔT	°C	4
Max condenser water ΔT	°C	8

Table 2 - Evaporator fouling factors

Fouling factors $m^2\text{°C} / kW$	Cooling capacity correction factor	Power input correction factor	EER correction factor
0.0176	1.000	1.000	1.000
0.0440	0.978	0.986	0.992
0.0880	0.957	0.974	0.983
0.1320	0.938	0.962	0.975

Minimum glycol percentage for low water temperature 3 - Condenser fouling factors

Fouling factors $m^2\text{°C} / kW$	Cooling capacity correction factor	Power input correction factor	EER correction factor
0.0176	1.000	1.000	1.000
0.0440	0.978	0.986	0.992
0.0880	0.957	0.974	0.983
0.1320	0.938	0.962	0.975

Table 4.1 - Condenser fouling factors

Evaporator leaving water temperature °C	2	0	-2	-4	-6	-8
Ethylene glycol (%)	10	20	20	20	30	30
Propylene glycol (%)	10	20	20	30	30	30

Note: Minimum glycol percentage to be used with evaporator leaving water temperature below 4°C to prevent freezing of water circuit.

Table 4.2 - Minimum glycol percentage for low air temperature

Air ambient temperature (°C) (2)	-3	-8	-15	-23	-35
Ethylene glycol (%) (1)	10%	20%	30%	40%	50%
Air ambient temperature (°C) (2)	-3	-7	-12	-20	-32
Propylene glycol (%) (1)	10%	20%	30%	40%	50%

Note (1): Minimum glycol percentage to prevent freezing of water circuit at indicated air ambient temperature

Note (2): Air ambient temperature do exceed the operating limits of the unit, as protection of water circuit may be needed in winter season at non-working conditions.

Table 5 - Correction factors for low evaporator leaving water temperature

Evaporator leaving water temperature °C	2	0	-2	-4	-6	-8
Cooling capacity	0.842	0.785	0.725	0.670	0.613	0.562
Compressor power input	0.950	0.940	0.920	0.890	0.870	0.840

Note: Correction factors have to be applied at working conditions: evaporator leaving water temperature 7°C

Table 6 - Correction factors for water and glycol mixture

Ethylene glycol	Ethylene glycol (%)	10%	20%	30%	40%	50%
	Cooling capacity	0.991	0.982	0.972	0.961	0.946
Compressor power input	0.996	0.992	0.986	0.976	0.966	
Flow Rate (Δt)	1.013	1.04	1.074	1.121	1.178	
Evaporator Pressure Drop	1.070	1.129	1.181	1.263	1.308	
Ethylene glycol	Cooling capacity	0.985	0.964	0.932	0.889	0.846
	Compressor power input	0.993	0.983	0.969	0.948	0.929
	Flow Rate (Δt)	1.017	1.032	1.056	1.092	1.139
	Evaporator Pressure Drop	1.120	1.272	1.496	1.792	2.128

OPL_1-2-3_Rev.00_2

11 Operation range

11 - 1 Operation Range

11

How to use the Correction factors proposed in the previous tables

A) Mixture Water and Glycol---Evaporator leaving water temperature > 4°C

- depending from the type and percentage (%) of glycol filled in the circuit (see table 4.2 and 6)
- multiply the Cooling Capacity, the Compressor Power Input by the Correction factor of Table 6
- starting from this new value of Cooling Capacity, calculate the Flow Rate (l/s) and the Evaporator Pressure Drop (kPa)
- now multiply the new Flow Rate and the new Evaporator Pressure Drop by the Correction Factors of Table 6

Example

Unit size: **EWWD120J-SS**

Mixture: Water
 Working condition: ELWT 12/7°C - CLWT 30/35°C
 - Cooling capacity: 121 kW
 - Power input: 27.3 kW
 - Flow Rate (Δt 5°C): 5.78
 - Evaporator Pressure Drop: 15kPa

Mixture: Water+Ethylene glycol 30% (for a winter air temperature up to -15°C)
 Working condition: ELWT 12/7°C - CLWT 30/35°C
 - Cooling capacity: $121 \times 0.972 = 118 \text{ kW}$
 - Power input: $27.3 \times 0.986 = 26.9 \text{ kW}$
 - Flow Rate (Δt 5°C): $5.64 \text{ l/s (referred to 118 kW)} \times 1.074 = 6.06 \text{ l/s}$
 - Evaporator Pressure Drop: $16 \text{ (referred to 6.06 l/s)} \times 1.181 = 19 \text{ kPa}$

B) Mixture Water and Glycol---Evaporator leaving water temperature < 4°C

- depending from the type and percentage (%) of glycol filled in the circuit (see table 4.1 and 4.2 and table 6)
- depending from the evaporator leaving water temperature (see table 5)
- multiply the Cooling Capacity, the Compressor Power Input by the Correction factor of Table 5 and Table 6
- starting from this new value of Cooling Capacity, calculate the Flow Rate (l/s) and the Evaporator Pressure Drop (kPa)
- now multiply the new Flow Rate and the new Evaporator Pressure Drop by the Correction Factors of Table 6

Example

Unit size: **EWWD120J-SS**

Mixture: Water
 Working condition: ELWT 12/7°C - CLWT 30/35°C
 - Cooling capacity: 121 kW
 - Power input: 27.3 kW
 - Flow Rate (Δt 5°C): 5.78
 - Evaporator Pressure Drop: 15kPa

Mixture: Water+Ethylene glycol 30% (for a low evaporator leaving temperature of 0/-5°C)
 Working condition: ELWT 0/-5°C - CLWT 30/35°C
 - Cooling capacity: $121 \times 0.641 \times 0.972 = 75.4 \text{ kW}$
 - Power input: $27.3 \times 0.880 \times 0.986 = 23.7 \text{ kW}$
 - Flow Rate (Δt 5°C): $3.60 \text{ l/s (referred to 75.4 kW)} \times 1.074 = 3.87 \text{ l/s}$
 - Evaporator Pressure Drop: $7 \text{ kPa (referred to 3.87 l/s)} \times 1.181 = 9 \text{ kPa}$

OPL_1-2-3_Rev.00_3

12 Specification text

12 - 1 Specification Text

Technical Specification for Water Cooled Screw Chiller

General

The water cooled screw chiller will be designed and manufactured in accordance with following European directives:

Construction of pressure vessel	97/23/EC (PED)
Machinery Directive	2006/42/EC
Low Voltage	2006/95/EC
Electromagnetic Compatibility	2004/108/EC
Electrical & Safety Codes	EN 60204-1 / EN 60335-2-40
Manufacturing Quality Stds	UNI - EN ISO 9001:2004

The unit will be tested at full load in the factory at the nominal working conditions and water temperatures. Before shipment a full test will be held to avoid any losses.

Chiller will be delivered to the job site completely assembled and charged with refrigerant and oil. Comply with the manufacturer instructions for rigging and handling equipment.

The unit will be able to start up and operate as standard at full load and condenser entering fluid temperature from . . . °C to . . . °C with an evaporator leaving fluid temperature between . . . °C and °C

All units published performances have to be certified by **Eurovent**.

Refrigerant

Only HFC 134a will be accepted.

Freeze protection

- ✓ Number of water cooled screw chiller:
- ✓ Cooling capacity for single water cooled screw chiller: kW
- ✓ Power input for single water cooled screw chiller in cooling mode: kW
- ✓ Plate to plate evaporator entering water temperature in cooling mode: °C
- ✓ Plate to plate evaporator leaving water temperature in cooling mode: °C
- ✓ Plate to plate evaporator water flow: l/s
- ✓ Shell & tube condenser entering water temperature in cooling mode: °C
- ✓ Shell & tube condenser leaving water temperature in cooling mode: °C
- ✓ Shell & tube condenser water flow: l/s
- ✓ The unit should work with electricity in range 400V ±10%, 3ph, 50Hz without neutral and shall only have one power connection point.

Unit description

Chiller shall include as standard: 1 or 2 independent refrigerant circuits, semi-hermetic rotary single screw compressors, electronic expansion device (EEXV), direct expansion plate to plate evaporator and shell & tube condenser, R134a refrigerant, lubrication system, motor starting components, control system and all components necessary for safe and stable unit operation. Chiller will be factory assembled on a robust base-frame made of zinc coated steel, protected by an epoxy paint.

Noise level and vibration

Sound pressure level at 1 meter distance in free field, semispheric conditions, shall not exceed dBA. The sound pressure levels must be rated in accordance to ISO 3744. Other types of rating unacceptable. Vibration level should not exceed 2 mm/s.

Dimension

Unit dimensions shall not exceed following indications:

- ✓ unit length: mm,
- ✓ unit width: mm,
- ✓ unit height: mm.

SPC_1-2-3_Rev.00_1

12 Specification text

12 - 1 Specification Text

Chiller Components

Compressors

- ✓ Semi-hermetic, single-screw type with one main helical rotor meshing with gaterotor. The gaterotor will be constructed of a carbon impregnated engineered composite material. The gaterotor supports will be constructed of cast iron.
- ✓ The oil injection shall be used in order to get high EER (Energy Efficiency Ratio) also at high condensing pressure and low sound pressure levels in each load condition.
- ✓ Refrigerant system differential pressure shall provide oil flow through service replaceable, 0.5 micron, full flow, cartridge type oil filter internal to compressor.
- ✓ Refrigerant system differential pressure shall provide oil injection on all moving compressor parts to correctly lubricate them. Electrical oil pump lubricating system is not acceptable.
- ✓ The compressor's oil cooling must be realized, when necessary, by refrigerant liquid injection. External dedicated heat exchanger and additional piping to carry the oil from the compressor to heat exchanger and viceversa will be not accepted.
- ✓ The compressor shall be provided with an external, high efficiency, cyclonic type oil separator and with built-in oil filter, cartridge type.
- ✓ The compressor shall be direct electrical driven, without gear transmission between the screw and the electrical motor.
- ✓ Shall be present two thermal protection realized by a thermistor for high temperature protection: one temperature sensor to protect electrical motor and another sensor to protect unit and lubricating oil from high discharge gas temperature.
- ✓ The compressor shall be equipped with an electric oil-crankcase heater.
- ✓ Compressor shall be fully field serviceable. Compressor that must be removed and returned to the factory for service shall be unacceptable.

Cooling capacity control system

- ✓ Each unit will have a microprocessor for the control of compressor slide valve's position and instantaneous RPM value of the motor.
- ✓ The unit capacity control shall be infinitely modulating, from 100% down to 25% for each circuit (from 100% down to 12,5% of full load for unit with 2 compressors). The chiller shall be capable of stable operation to a minimum of 12,5% of full load without hot gas bypass.
- ✓ Step unloading unacceptable because of evaporator leaving water temperature fluctuation and low unit efficiency at partial load.
- ✓ The system shall stage the unit based on the leaving evaporator water temperature fluctuation that shall be controlled by a PID (Proportional Integral Derivative) loop.
- ✓ Unit control logic shall to manage frequency level of the compressor electric motor to exactly match plant load request in order to keep constant the set point for delivered chilled water temperature. In this operation condition unit control logic shall modulate electrical frequency level in a range lower and upper the nominal electrical network value at 50 Hz.
- ✓ The microprocessor unit control shall detect conditions that approach protective limits and take self-corrective action prior to an alarm occurring. The system shall automatically reduce chiller capacity when any of the following parameters are outside their normal operating range:
 - High condenser pressure
 - Low evaporation refrigerant temperature
 - High compressor motor amps

Evaporator

- ✓ The units shall be equipped with a Direct Expansion plate to plate evaporator with copper tubes rolled into steel tubesheets.
- ✓ The external shell shall be linked with an electrical heater to prevent freezing down to -28°C ambient temperature, controlled by a thermostat and shall be insulated with flexible, closed cell polyurethane insulation material (10 mm thick).
- ✓ The evaporator will have 1 circuit.
- ✓ The water connections shall be threaded type connections as standard to ensure quick mechanical disconnection between the unit and the hydronic network.
- ✓ Evaporator is manufactured in accordance to PED approval.

SPC_1-2-3_Rev.00_2

12 Specification text

12 - 1 Specification Text

Condensers

- ✓ Condensers will be shell and cleanable, through-tube type.
- ✓ The unit will have one condensers per circuit.
- ✓ Each condenser shall have a carbon steel and seamless, integrally finned high efficiency copper tubes, roll expanded into heavy carbon steel tube sheets.
- ✓ Water heads shall be removable and include vent and drain plugs.
- ✓ Condensers will come complete with liquid shut-off valve, spring loaded relief valve.

Refrigerant circuit

Each circuit shall include as standard: electronic expansion device piloted by unit's microprocessor control, compressor discharge shut-off valve, suction line shut-off valve, replaceable core filter-drier, sight glass with moisture indicator and insulated suction line.

Control panel

- ✓ Field power connection, control interlock terminals, and unit control system should be centrally located in an electric panel (IP 54). Power and starting controls should be separate from safety and operating controls in different compartments of the same panel.
- ✓ Starting shall be Wye-Delta type as standard.
- ✓ Operating and safety controls should include energy saving control; emergency stop switch; overload protection for compressor motor, high and low pressure cut-out switch (for each refrigerant circuit); anti-freeze thermostat; cut-out switch for each compressor.
- ✓ All of the information regarding the unit will be reported on a display and with the internal built-in calendar and clock that will switch the unit ON/OFF during day time all year long.
- ✓ The following features and functions shall be included:
 - Resetting chilled water temperature by controlling the return water temperature or by a remote 4-20 mA DC signal or by controlling the external ambient temperature;
 - Soft load function to prevent the system from operating at full load during the chilled fluid pulldown period;
 - Password protection of critical parameters of control;
 - Start-to-start and stop-to-start timers to provide minimum compressor off-time with maximum motor protection;
 - Communication capability with a PC or remote monitoring;
 - discharge pressure control through intelligent cycling of condenser fans;
 - Lead-lag selection by manual or automatically by circuit run hours;
 - Double set point for brine unit version;
 - Scheduling via internal time clock to allow programming of a yearly start-stop schedule accommodating weekends and holidays.

Optional High Level Communications Interface

The controller as a minimum shall be capable of providing the data shown in the above list, using the following options:

- RS485 Serial Card
- RS232 Serial Card
- LonWorks interface to FTT10A Transceiver.
- Bacnet Compatible
- Use of Compass Points (manufactured by North Communications) to allow communications with such as Honeywell, Satchwell, Johnson controls, Trend etc.

SPC_1-2-3_Rev.00_3

In all of us,
a green heart



Daikin's unique position as a manufacturer of air conditioning equipment, compressors and refrigerants has led to its close involvement in environmental issues. For several years Daikin has had the intention to become a leader in the provision of products that have limited impact on the environment. This challenge demands the eco design and development of a wide range of products and an energy management system, resulting in energy conservation and a reduction of waste.

The present leaflet is drawn up by way of information only and does not constitute an offer binding upon Daikin Europe N.V. Daikin Europe N.V. has compiled the content of this leaflet to the best of its knowledge. No express or implied warranty is given for the completeness, accuracy, reliability or fitness for particular purpose of its content and the products and services presented therein. Specifications are subject to change without prior notice. Daikin Europe N.V. explicitly rejects any liability for any direct or indirect damage, in the broadest sense, arising from or related to the use and/or interpretation of this leaflet. All content is copyrighted by Daikin Europe N.V.



Daikin Europe N.V. participates in the Eurovent Certification programme for Air Conditioners (AC), Liquid Chilling Packages (LCP) and Fan Coil Units (FC); the certified data of certified models are listed in the Eurovent Directory. Multi units are Eurovent certified for combinations up to 2 indoor units.



ECDEN11-413

Daikin products are distributed by: