



Chillers

Technical Data

Water Cooled Chiller



ECDEN11-411

EWWP-KBW1N
EWLP-KBW1N

R-407C



Chillers

Technical Data

Water Cooled Chiller



ECDEN11-411

EWWP-KBW1N
EWLP-KBW1N

R-407C

TABLE OF CONTENTS

EWWP-KBW1N

1	Features	2
2	Specifications	3
	Technical Specifications	3
	Technical Specifications	4
	Electrical Specifications	5
	Electrical Specifications	5
3	Options	6
	Options	6
4	Capacity tables	7
	Cooling/Heating Capacity Tables	7
	Capacity Correction Factor	11
5	Dimensional drawings	12
	Dimensional Drawings	12
6	Centre of gravity	16
	Centre of Gravity	16
7	Piping diagrams	18
	Piping Diagrams	18
8	Wiring diagrams	22
	Wiring Diagrams - Three Phase	22
9	Sound data	24
	Sound Power Spectrum	24
10	Operation range	27
	Operation Range	27
11	Hydraulic performance	29
	Water Pressure Drop Curve Evaporator/Condenser	29

1 Features

- Standard integrated: main switch, water filter, flow switch, air purge, pressure ports
- Daikin scroll compressor
- Optimised for use with R-407C
- Electronic DDC controller
- Low operating sound level
- Low energy consumption
- Extension possible up to 72HP
- Compact dimensions and low refrigerant volume
- Easy installation and maintenance
- Stainless steel plate heat exchanger
- Remote cooling or heating selection
- Water/water heat pump, with water reversibility
- Compatible with hydraulic module



1

1

2 Specifications

2-1 Technical Specifications				EWWP014 KBW1N	EWWP022 KBW1N	EWWP028 KBW1N	EWWP035 KBW1N	EWWP045 KBW1N	EWWP055 KBW1N	EWWP065 KBW1N	EWWP090 KBW1N	EWWP100 KBW1N	EWWP110 KBW1N		
Cooling capacity	Nom.	kW		13.0	21.5	28.0	32.5	43.0	56.0	65.0	86.0	99.0	112		
Heating capacity	Nom.	kW		16.6	27.3	35.4	41.2	54.8	71.4	82.7	110	126	143		
Capacity steps number				1				2			4				
Power input	Cooling	Nom.	kW	3.61	5.79	7.48	8.75	11.80	15.50	17.60	23.6	27.3	31.0		
Casing	Colour	Ivory white (Munsell code: 5Y7.5/1)													
	Material	Polyester painted steel plate													
Dimensions	Unit	Height	mm	600						1,200					
		Width	mm	600											
		Depth	mm	600						1,200					
Weight	Unit	kg	118	155	165	172	300	320	334	600	620	640			
Water heat exchanger - evaporator	Type	Brazed plate													
	Minimum water volume in the system	l	62	103	134	155	205	268	311	205	268				
	Water flow rate	Min.	l/min	19	31	40	47	62	80	93	123	142	161		
		Nom.	l/min	37	62	80	93	123	161	186	247	284	321		
		Max.	l/min	75	123	161	186	247	321	373	493	568	642		
Insulation material	Polyethylene foam														
Model	Quantity	1						2							
Water heat exchanger - condenser	Type	Brazed plate													
	Water flow rate	Min.	l/min	24	39	51	59	79	102	118	157	181	205		
		Nom.	l/min	48	78	102	118	157	205	237	314	362	410		
		Max.	l/min	95	157	203	237	314	410	474	629	724	819		
Model	Quantity	1						2							
Sound power level	Cooling	Nom.	dBA	64			71	67		74	71				
Compressor	Type	Hermetically sealed scroll compressor													
	Quantity	1				2				4	2	4			
	Model	JT140B F-YE	JT212D A-YE	JT300D A-YE	JT335D A-YE	JT212D A-YE	JT300D A-YE	JT335D A-YE	JT212DA-YE			JT300D A-YE			
	Speed	rpm	2,900												
	Oil	Charged volume	l	1.5	2.7										
Compressor 2	Quantity	-										2	-		
	Model	-										JT300D A-YE	-		
	Speed	rpm	-										2,900	-	
	Oil	Charged volume	l	-										2.7	-
Refrigerant	Type	R-407C													
	Charge	kg	1.2	2	2.5	3.1	4.6		5.6	-					
	Control	Thermostatic expansion valve													
	Circuits	Quantity	1				2				4				
Refrigerant circuit	Charge	kg	-										9.2		
Refrigerant oil	Type	FVC68D													
Piping connections	Evaporator water inlet/outlet	FBSP 25mm				FBSP 40mm				2 x 2 x FBSP 38mm					
	Evaporator water drain	Field installation													
	Condenser water inlet/outlet	FBSP 25mm				FBSP 40mm				2 x 2 x FBSP 38mm					
	Condenser water drain	Field installation													

1
2

2 Specifications

2-2 Technical Specifications				EWWP120 KBW1N	EWWP130 KBW1N	EWWP145 KBW1N	EWWP155 KBW1N	EWWP165 KBW1N	EWWP175 KBW1N	EWWP185 KBW1N	EWWP195 KBW1N	
Cooling capacity	Nom.	kW		121	130	142	155	168	177	186	195	
Heating capacity	Nom.	kW		154	165	181	198	214	226	237	248	
Capacity steps number				4				6				
Power input	Cooling	Nom.	kW	33.1	35.2	39.1	42.8	46.5	48.6	50.7	52.8	
Casing	Colour	Ivory white (Munsell code: 5Y7.5/1)										
	Material	Polyester painted steel plate										
Dimensions	Unit	Height	mm	1,200				1,800				
		Width	mm	600								
		Depth	mm	1,200								
Weight	Unit	kg	654	668	920	940	960	974	988	1,002		
Water heat exchanger - evaporator	Type	Brazen plate										
	Minimum water volume in the system	l	311			205			268			311
	Water flow rate	Min.	l/min	173	186	204	222	241	254	267	280	
		Nom.	l/min	347	373	407	444	482	507	533	559	
		Max.	l/min	694	745	814	889	963	1,015	1,066	1,118	
	Insulation material	Polyethylene foam										
Model	Quantity	2										
Water heat exchanger - condenser	Type	Brazen plate										
	Water flow rate	Min.	l/min	221	237	260	283	307	323	339	355	
		Nom.	l/min	442	474	519	567	614	647	679	711	
		Max.	l/min	883	948	1,038	1,133	1,229	1,293	1,357	1,422	
	Model	Quantity	2									
Sound power level	Cooling	Nom.	dB(A)	75	77	73			76	78	79	
Compressor	Type	Hermetically sealed scroll compressor										
	Quantity	2			4			6	4			6
	Model	JT300DA- YE		JT335DA- YE	JT212DA- YE	JT300DA- YE			JT335DA- YE			
	Speed	rpm		2,900								
	Oil	Charged volume	l	2.7								
	Compressor 2	Quantity	2			-	2			-	2	
Model		JT335DA- YE		-	JT300DA- YE	JT212DA- YE	-	JT335DA- YE	JT300DA- YE		-	
Speed		rpm		2,900	-	2,900			-	2,900		-
Oil		Charged volume	l	2.7	-	2.7			-	2.7		-
Refrigerant		Type	R-407C									
	Charge	kg	-									
	Control	Thermostatic expansion valve										
	Circuits	Quantity	4				6					
Refrigerant circuit	Charge	kg	10.2	11.2	13.8			14.8	15.8	16.8		
Refrigerant oil	Type	FVC68D										
Piping connections	Evaporator water inlet/outlet	2 x 2 x FBSP 38mm				3 x 2 x FBSP 38mm						
	Evaporator water drain	Field installation										
	Condenser water inlet/outlet	2 x 2 x FBSP 38mm				3 x 2 x FBSP 38mm						
	Condenser water drain	Field installation										

1
2

2 Specifications

2-3 Electrical Specifications			EWWP014 KBW1N	EWWP022 KBW1N	EWWP028 KBW1N	EWWP035 KBW1N	EWWP045 KBW1N	EWWP055 KBW1N	EWWP065 KBW1N	EWWP090 KBW1N	EWWP100 KBW1N	EWWP110 KBW1N		
Compressor	Phase		3~											
	Frequency	Hz	50							-				
	Voltage		400											
	Starting current	A	49	79	109	129	79	109	129	79	109			
	Nominal running current (RLA)	A	6.6	10.4	13.1	15.0	10.4	13.1	15.0	10.4	13.1			
	Maximum running current	A	9	14.5	18.5	22	14	18	20	14	18			
	Starting method		Direct on line											
Compressor 2	Phase		-							3~		-		
	Voltage		-							400		-		
	Starting current		-							109		-		
	Nominal running current (RLA)		-							13.1		-		
	Maximum running current		-							18		-		
Power supply	Name		W1											
	Phase		3N~											
	Frequency	Hz	50											
	Voltage		400											
	Voltage range	Min.	%	-10										
		Max.	%	10										
Unit	Starting current		A	49	79	109	129	93	127	149	-			
	Maximum starting current		A	-							121	155	163	
	Current	Zmax	Text	0.24 + j0.15	0.20 + j0.12	0.18 + j0.12	0.18 + j0.11	0.18 + j0.12	0.18 + j0.11	0.17 + j0.11	-			
	Nominal running current (RLA)	Cooling	A	6.6	10.4	13.1	15.0	20.8	26.2	30	41.6	47	52.4	
	Maximum running current		A	9	14.5	18.5	22	28	36	40	56	64	72	
	Recommended fuses according to IEC standard 269-2			3 x 16aM	3 x 20aM	3 x 25aM		3 x 35aM	3 x 40aM	3 x 50aM	3 x 63aM		3 x 80aM	

2-4 Electrical Specifications			EWWP120 KBW1N	EWWP130 KBW1N	EWWP145 KBW1N	EWWP155 KBW1N	EWWP165 KBW1N	EWWP175 KBW1N	EWWP185 KBW1N	EWWP195 KBW1N			
Compressor	Phase		3~										
	Frequency	Hz	-										
	Voltage		400										
	Starting current	A	109	129	79		109			129			
	Nominal running current (RLA)	A	13.1	15	10.4		13.1			15			
	Maximum running current	A	18	20	14		18			20			
	Starting method		Direct on line										
Compressor 2	Phase		3~	-	3~		-	3~		-			
	Voltage		V	400	-	400		-	400		-		
	Starting current		A	129	-	109		-	129		-		
	Nominal running current (RLA)		A	15	-	13.1		-	15		-		
	Maximum running current		A	20	-	18		-	20		-		
Power supply	Name		W1										
	Phase		3N~										
	Frequency	Hz	50										
	Voltage		400										
	Voltage range	Min.	%	-10									
		Max.	%	10									
Unit	Starting current		A	-									
	Maximum starting current		A	185	189	183	191	199	221	225	229		
	Current	Zmax	Text	-									
	Nominal running current (RLA)	Cooling	A	56.2	60	67.8	73.2	78.6	82.4	86.2	90		
	Maximum running current		A	76	80	92	100	108	112	116	120		
	Recommended fuses according to IEC standard 269-2			3 x 80aM			3 x 100aM			3 x 125aM			

3 Options

3 - 1 Options

1
3

EWWP-KBW1
EWLP-KBW1

Optional equipment for EWW/LP-KBW1

Modelnumber

EWWP014KBW1N*	EWWP045KBW1N*	EWLP012KBW1N*	EWLP040KBW1N*
EWWP022KBW1N*	EWWP055KBW1N*	EWLP020KBW1N*	EWLP055KBW1N*
EWWP028KBW1N*	EWWP065KBW1N*	EWLP026KBW1N*	EWLP065KBW1N*
EWWP035KBW1N*		EWLP030KBW1N*	

Option number	Option description	Unit size							Availability
		014WC - 012RC	022WC - 020RC	028WC - 026RC	035WC - 030RC	045WC - 040RC	055WC - 055RC	065WC - 065RC	
	Standard unit	•	•	•	•	•	•	•	
	Not completely combinable options								
ZH	Glycol operation chilled water temp down to -5°C	•	•	•	•	•	•	•	Factory mounted
ZL	Glycol operation chilled water temp down to -10°C	•	•	•	•	•	•	•	Factory mounted
EKAC10C	Available kits Address card for connection to BMS or Remote user interface	•	•	•	•	•	•	•	Kit
EKRUMCA	Remote installed user interface	•	•	•	•	•	•	•	Kit
EKLS1	Low noise operation EUW*5KZW1	•1	—	—	—	—	—	—	Kit
EKLS2	Low noise operation EUW*8-24KZW1	—	•1	•1	•1	•2	•2	•2	Kit
EHMC10AV1010/1080	Hydraulic module	•	•	•	•	•	•	•	Kit
EHMC15AV1010/1080	Hydraulic module	—	—	•	•	—	—	—	Kit
EHMC30AV1010/1080	Hydraulic module	—	—	—	—	•	•	•	Kit

NOTES

- std = standard on unit
 - = available
 - x = available and a quantity of x is needed for this unit size
 - = not available
- Hatched area = preliminary data
- * = option number
- To install EKRUMCA => EKAC10C needs to be installed on the unit.
- EKAC10C : this address card allows direct connection to MODBUS BMS system

4TW60149-5

4 Capacity tables

4 - 1 Cooling/Heating Capacity Tables

LWC		20			25			30			35			40			45			50			55		
LWE	MODEL	CC	HC	PI	CC	HC	PI	CC	HC	PI	CC	HC	PI	CC	HC	PI	CC	HC	PI	CC	HC	PI	CC	HC	PI
-10	014	8,0	10,8	2,75	7,5	10,5	2,95	7,0	10,2	3,20	6,4	9,9	3,49	5,7	9,6	3,82	5,0	9,2	4,19	-	-	-	-	-	-
	022	12,4	16,0	3,55	12,2	16,2	4,02	11,5	16,1	4,53	10,7	15,8	5,08	9,8	15,4	5,66	8,7	15,0	6,29	-	-	-	-	-	-
	028	16,4	21,6	5,18	16,4	22,2	5,80	16,1	22,6	6,50	15,3	22,6	7,29	14,3	22,4	8,17	12,9	22,1	9,14	-	-	-	-	-	-
	035	20,9	27,0	6,12	20,8	27,4	6,89	20,6	28,0	7,41	19,7	28,0	8,27	18,2	27,5	9,29	16,3	26,7	10,47	-	-	-	-	-	-
-5	014	9,9	12,7	2,75	9,4	12,4	2,97	8,9	12,1	3,23	8,3	11,8	3,56	7,6	11,5	3,87	6,9	11,2	4,25	6,2	10,9	4,63	-	-	-
	022	15,9	19,7	3,77	15,4	19,6	4,25	14,7	19,5	4,77	13,9	19,2	5,34	12,9	18,9	5,95	11,8	18,4	6,61	10,5	17,8	7,31	-	-	-
	028	20,1	25,4	5,35	20,1	26,0	5,94	19,8	26,4	6,62	18,9	26,3	7,40	18,1	26,4	8,26	16,8	26,0	9,22	15,4	25,6	10,28	-	-	-
	035	24,4	30,6	6,25	24,3	31,1	6,84	24,1	31,7	7,56	23,3	31,8	8,42	22,0	31,5	9,42	20,2	30,9	10,61	18,0	29,8	11,81	-	-	-
0	014	11,9	14,7	2,77	11,4	14,4	3,00	10,9	14,2	3,27	10,3	13,9	3,60	9,7	13,6	3,94	8,9	13,3	4,33	8,1	12,9	4,73	7,3	12,5	5,23
	022	18,8	22,8	4,01	18,3	22,8	4,46	17,6	22,5	4,97	16,8	22,4	5,55	15,8	22,0	6,18	14,7	21,5	6,88	13,4	21,0	7,64	12,1	20,5	8,45
	028	23,7	29,2	5,46	23,7	29,7	5,99	23,4	30,1	6,63	22,6	30,0	7,37	21,9	30,1	8,21	20,6	29,8	9,14	19,2	29,4	10,18	17,2	28,5	11,31
	035	27,9	34,2	6,22	27,8	34,7	6,87	27,7	35,3	7,62	26,9	35,4	8,49	25,7	35,2	9,47	24,1	34,9	10,74	22,0	33,8	11,75	19,5	32,7	13,17
4	014	13,1	15,8	2,73	12,9	15,9	2,99	12,5	15,8	3,28	12,0	15,7	3,63	11,4	15,4	3,97	10,7	15,1	4,37	10,0	14,8	4,79	9,1	14,4	5,29
	022	20,8	24,9	4,07	20,6	25,1	4,55	20,2	25,3	5,08	19,8	25,5	5,67	18,8	25,1	6,31	17,7	24,7	7,01	16,4	24,1	7,76	14,6	23,2	8,56
	028	26,7	32,2	5,51	26,7	32,7	6,05	26,4	33,1	6,70	25,7	33,2	7,49	24,9	33,2	8,29	23,7	32,9	9,22	22,2	32,5	10,24	20,3	31,8	11,47
	035	30,8	37,2	6,44	30,7	37,8	7,09	30,6	38,4	7,85	30,0	38,7	8,71	28,9	38,6	9,71	27,5	38,3	10,80	25,6	37,6	12,00	23,4	36,7	13,27
7	014	14,3	17,1	2,76	14,0	17,0	3,00	13,5	16,9	3,29	13,0	16,6	3,61	12,3	16,3	3,98	11,6	16,0	4,37	10,9	15,7	4,84	10,1	15,4	5,33
	022	22,7	26,9	4,24	22,5	27,2	4,66	22,2	27,4	5,17	21,5	27,3	5,79	20,5	26,9	6,35	19,2	26,2	7,00	17,6	25,4	7,75	15,6	24,3	8,69
	028	28,9	34,5	5,56	28,9	35,0	6,11	28,6	35,4	6,76	28,0	35,4	7,48	27,1	35,5	8,35	26,0	35,2	9,25	24,5	34,8	10,32	22,6	34,1	11,45
	035	33,1	39,6	6,52	33,0	40,2	7,19	33,0	40,9	7,95	32,5	41,2	8,75	31,5	41,3	9,81	30,1	41,0	10,90	28,1	40,2	12,12	25,7	39,0	13,33
10	014	15,5	18,2	2,76	15,1	18,1	3,03	14,8	18,1	3,33	14,3	17,9	3,64	13,7	17,8	4,05	13,0	17,5	4,46	12,2	17,2	4,92	11,2	16,6	5,35
	022	24,6	28,8	4,22	24,4	29,1	4,67	24,0	29,2	5,19	23,3	29,1	5,78	22,3	28,8	6,40	21,1	28,2	7,10	19,5	27,3	7,85	17,6	26,3	8,69
	028	30,4	35,9	5,56	30,3	36,4	6,12	30,1	36,9	6,78	29,6	37,2	7,53	29,0	37,3	8,36	27,9	37,2	9,30	26,6	36,9	10,32	24,9	36,3	11,47
	035	34,5	41,1	6,61	34,4	41,7	7,29	34,3	42,3	8,05	33,7	42,6	8,90	32,8	42,7	9,89	31,4	42,4	10,97	29,6	41,8	12,14	27,5	40,9	13,37
14	014	16,2	19,0	2,75	16,2	19,2	3,06	16,2	19,6	3,38	16,0	19,7	3,67	15,6	19,7	4,12	14,9	19,5	4,55	14,0	19,0	5,02	12,8	18,2	5,37
	022	26,4	30,6	4,20	26,3	31,0	4,68	26,2	31,4	5,21	25,7	31,5	5,75	24,8	31,3	6,46	23,6	30,8	7,19	22,0	30,0	7,98	20,2	28,9	8,68
	028	32,3	37,8	5,56	32,2	38,3	6,13	32,2	38,9	6,78	31,9	39,5	7,55	31,4	39,8	8,37	30,6	39,9	9,29	29,4	39,8	10,31	27,9	39,4	11,49
	035	38,4	45,0	6,67	38,3	45,7	7,35	38,0	46,1	8,12	37,4	46,4	9,00	36,5	46,4	9,94	35,2	46,2	10,98	33,7	45,8	12,11	31,0	44,4	13,36
16	014	16,7	19,5	2,74	16,7	19,8	3,06	16,7	20,0	3,38	16,5	20,2	3,68	16,2	20,3	4,13	15,6	20,2	4,55	14,8	19,8	5,01	13,7	19,0	5,37
	022	27,2	31,4	4,19	27,1	31,8	4,67	27,0	32,2	5,20	26,6	32,4	5,74	25,8	32,3	6,45	24,7	31,9	7,17	23,2	31,2	7,96	21,5	30,1	8,68
	028	32,6	38,2	5,57	32,6	38,7	6,15	32,5	39,3	6,82	32,3	39,9	7,58	31,9	40,3	8,41	31,2	40,5	9,34	30,2	40,6	10,36	28,9	40,4	11,49
	035	38,8	45,5	6,70	38,7	46,1	7,39	38,5	46,7	8,17	38,1	47,1	9,06	37,3	47,3	9,99	36,1	47,2	11,03	34,7	46,8	12,16	32,9	46,4	13,43
20	014	17,6	20,3	2,73	17,6	20,6	3,05	17,5	20,9	3,38	17,5	21,2	3,69	17,4	21,5	4,12	17,0	21,5	4,54	16,3	21,3	4,99	15,4	20,7	5,36
	022	28,9	33,0	4,16	28,8	33,4	4,64	28,7	33,9	5,17	28,5	34,2	5,71	28,0	34,4	6,41	27,0	34,2	7,13	25,8	33,7	7,92	24,0	32,6	8,67
	028	33,2	38,8	5,58	33,2	39,4	6,19	33,1	40,0	6,88	33,1	40,8	7,63	32,9	41,4	8,49	32,4	41,9	9,42	31,8	42,2	10,44	31,0	42,5	11,50
	035	40,9	47,6	6,67	40,8	48,2	7,38	40,8	49,0	8,17	40,7	49,8	9,09	40,7	50,7	9,98	40,6	51,6	11,02	39,2	51,3	12,14	37,4	50,9	13,49

4TW57192-1

SYMBOLS

- CC : Cooling capacity (kW)
- HC : Heating capacity (kW)
- PI : Power input (kW)
- LWE : Leaving Water Evaporator (°C)
- LWC : Leaving Water Condenser (°C)

NOTES

- 1 Cooling capacity is according to Eurovent rating standard 6/C/003-2003 and valid for chilled water range Dt = 3-8°C
- 2 Heating capacity is according to Eurovent rating standard 6/C/003-2003 and valid for chilled water range Dt = 3-8°C
- 3 Power input is total input according to Eurovent rating standard 6/C/003-2003.

4 Capacity tables

4 - 1 Cooling/Heating Capacity Tables

1
4

LWC		20			25			30			35			40			45			50			55			
LWE	MODEL	CC	HC	PI	CC	HC	PI	CC	HC	PI	CC	HC	PI	CC	HC	PI	CC	HC	PI	CC	HC	PI	CC	HC	PI	
-10	045	24,8	32,2	7,5	24,3	32,7	8,5	23,0	32,4	9,5	21,4	31,9	10,6	19,5	31,1	11,7	17,3	30,2	13,0	-	-	-	-	-	-	-
	055	32,9	43,5	10,8	32,9	44,8	12,1	32,2	45,5	13,5	30,7	45,5	15,1	28,6	45,2	16,8	25,9	44,5	18,8	-	-	-	-	-	-	-
	065	41,9	54,2	12,3	41,5	55,0	13,5	41,2	55,9	14,9	39,4	55,8	16,6	36,5	55,0	18,7	32,5	53,3	21,0	-	-	-	-	-	-	-
-5	045	31,8	39,7	8,0	30,6	39,5	8,9	29,4	39,2	10,0	27,7	38,7	11,1	25,7	38,0	12,3	23,5	37,1	13,6	20,9	35,9	15,0	-	-	-	-
	055	40,2	51,2	11,2	40,2	52,4	12,4	39,7	53,2	13,7	37,8	52,9	15,3	36,3	53,2	17,0	33,7	52,5	18,9	30,8	51,7	21,0	-	-	-	-
	065	48,7	61,4	12,6	48,6	62,4	13,8	48,3	63,4	15,2	46,7	63,5	16,9	44,1	62,8	18,9	40,5	61,6	21,3	36,0	59,4	23,7	-	-	-	-
0	045	37,4	45,8	8,4	36,5	45,8	9,3	35,1	45,4	10,4	33,6	45,1	11,5	31,5	44,3	12,8	29,2	43,4	14,2	26,7	42,3	15,7	24,1	41,4	17,3	
	055	47,5	58,7	11,4	47,5	59,8	12,5	46,9	60,5	13,7	45,3	60,4	15,2	43,8	60,6	16,9	41,3	60,0	18,8	38,5	59,2	20,8	34,4	57,4	23,1	
	065	55,9	68,6	12,5	55,6	69,5	13,8	55,4	70,7	15,3	53,9	70,9	17,1	51,5	70,4	19,0	48,2	69,6	21,6	44,1	67,4	23,6	39,0	65,2	26,4	
4	045	43,6	51,9	8,3	42,5	51,8	9,3	41,1	51,5	10,3	39,5	51,1	11,5	37,5	50,3	12,8	35,2	49,5	14,2	32,7	48,4	15,7	30,1	47,4	17,3	
	055	53,5	64,9	11,5	53,5	66,0	12,6	52,8	66,6	13,9	51,5	66,9	15,5	49,8	66,8	17,1	47,5	66,3	18,9	44,5	65,4	21,0	40,7	64,0	23,4	
	065	61,6	74,9	13,0	61,5	76,0	14,3	61,1	77,0	15,8	59,9	77,5	17,5	57,9	77,4	19,5	55,0	76,6	21,7	51,3	75,2	24,1	46,9	73,3	26,6	
7	045	46,4	55,1	8,6	45,9	55,4	9,5	44,7	55,3	10,5	43,0	54,8	11,8	40,9	53,9	12,9	38,3	52,5	14,2	35,1	50,8	15,7	31,1	48,7	17,5	
	055	57,9	69,4	11,6	57,9	70,5	12,7	57,3	71,2	14,0	56,0	71,4	15,5	54,4	71,5	17,2	52,0	71,0	18,9	49,1	70,2	21,1	45,3	68,6	23,3	
	065	66,2	79,4	13,1	66,1	80,5	14,5	65,9	82,0	16,0	65,0	82,7	17,6	63,1	82,8	19,7	60,2	82,0	21,8	56,3	80,4	24,3	51,3	77,9	26,8	
10	045	49,1	57,8	8,6	48,7	58,3	9,5	47,9	58,5	10,6	46,6	58,3	11,7	44,6	57,6	13,0	42,0	56,5	14,4	38,9	54,8	15,9	35,1	52,7	17,6	
	055	60,9	72,4	11,6	60,7	73,4	12,7	60,3	74,3	14,0	59,4	74,8	15,5	58,0	75,2	17,2	56,0	75,0	19,1	53,3	74,4	21,1	49,8	73,1	23,4	
	065	69,0	84,1	13,3	68,9	85,2	14,7	68,5	86,5	16,2	67,5	87,1	17,9	65,5	87,1	19,9	62,8	86,5	22,0	59,3	85,2	24,4	55,0	83,3	26,8	
14	045	52,6	61,3	8,6	52,5	62,1	9,5	52,2	62,9	10,6	51,3	63,1	11,7	49,5	62,6	13,1	47,1	61,7	14,5	43,9	60,1	16,1	40,3	57,9	17,5	
	055	64,7	76,2	11,6	64,5	77,2	12,7	64,4	78,4	14,0	63,9	79,4	15,6	62,9	80,1	17,2	61,3	80,3	19,1	59,0	80,0	21,1	55,8	79,2	23,5	
	065	76,8	90,3	13,4	76,7	91,6	14,8	76,0	92,4	16,3	74,9	93,0	18,1	72,9	92,8	20,0	70,5	92,4	22,1	67,4	91,6	24,3	64,0	90,6	26,8	
16	045	54,3	62,9	8,5	54,2	63,8	9,5	54,0	64,6	10,6	53,2	64,9	11,6	51,6	64,7	13,1	49,4	63,9	14,5	46,4	62,6	16,1	42,8	60,4	17,5	
	055	65,3	76,8	11,6	65,2	77,9	12,8	65,1	79,1	14,1	64,7	80,3	15,6	63,9	81,1	17,3	62,5	81,6	19,2	60,5	81,6	21,2	57,9	81,3	23,5	
	065	77,7	93,0	13,5	77,5	94,2	14,8	77,0	95,2	16,4	76,2	96,1	18,2	74,5	96,3	20,0	72,3	96,1	22,1	69,3	95,3	24,4	65,9	94,4	26,9	
20	045	57,6	66,2	8,5	57,5	67,0	9,5	57,4	68,0	10,5	56,9	68,5	11,6	55,8	68,9	13,0	54,0	68,5	14,4	51,4	67,5	16,0	47,9	65,4	17,5	
	055	66,6	78,1	11,6	66,5	79,3	12,9	66,4	80,5	14,2	66,4	82,0	15,7	65,9	83,3	17,5	65,0	84,2	19,3	63,7	84,9	21,3	62,1	85,4	23,5	
	065	84,5	98,2	13,4	84,4	99,5	14,8	84,2	101	16,4	84,0	102	18,3	83,0	103	20,1	81,2	103	22,1	78,4	103	24,4	74,9	102	27,1	

4TW57232-1

SYMBOLS

- CC : Cooling capacity (kW)
- HC : Heating capacity (kW)
- PI : Power input (kW)
- LWE : Leaving water evaporator (°C)
- LWC : Leaving water condenser (°C)

NOTES

- 1 Cooling capacity is according to Eurovent rating standard 6/C/003-2003 and valid for chilled water range Dt = 3–8°C.
- 2 Heating capacity is according to Eurovent rating standard 6/C/003-2003 and valid for chilled water range Dt = 3–8°C.
- 3 Power input is total input according to Eurovent rating standard 6/C/003-2003.

4 Capacity tables

4 - 1 Cooling/Heating Capacity Tables

LWC		20.0			25.0			30.0			35.0			40.0			45.0			50.0			55.0			
LWE	MODEL	CC	HC	PI	CC	HC	PI	CC	HC	PI	CC	HC	PI	CC	HC	PI	CC	HC	PI	CC	HC	PI	CC	HC	PI	
-10	32	49.5	64.4	15.0	48.7	65.4	16.9	46.0	64.8	18.9	42.8	63.7	21.1	38.9	62.3	23.5	34.5	60.4	26.0	-	-	-	-	-	-	-
	36	57.6	75.7	18.4	57.3	77.5	20.5	55.2	77.8	23.0	52.1	77.4	25.6	48.1	76.4	28.6	43.2	74.7	31.8	-	-	-	-	-	-	-
	40	65.7	87.0	21.7	65.9	89.6	24.2	64.4	90.9	27.0	61.4	91.1	30.1	57.2	90.5	33.7	51.9	89.0	37.5	-	-	-	-	-	-	-
	44	74.7	97.7	23.2	74.5	99.8	25.6	73.4	101	28.4	70.1	101	31.7	65.1	100	35.5	58.4	97.8	39.8	-	-	-	-	-	-	-
-5	32	63.6	79.4	15.9	61.3	79.0	17.8	58.7	78.5	19.9	55.4	77.4	22.2	51.4	76.0	24.6	47.0	74.1	27.2	41.7	71.7	30.1	-	-	-	-
	36	72.0	90.9	19.2	70.9	91.9	21.3	69.0	92.4	23.7	65.5	91.6	26.4	62.1	91.1	29.3	57.2	89.5	32.6	51.7	87.5	36.1	-	-	-	-
	40	80.4	102	22.4	80.5	105	24.7	79.3	106	27.5	75.6	106	30.6	72.7	106	34.0	67.4	105	37.9	61.6	103	42.1	-	-	-	-
	44	88.9	113	23.8	88.8	115	26.1	88.0	117	28.9	84.5	116	32.2	80.4	116	35.9	74.2	114	40.3	66.8	111	44.8	-	-	-	-
0	32	74.9	91.7	16.9	73.1	91.7	18.7	70.1	90.8	20.7	67.2	90.1	23.0	63.1	88.6	25.6	58.5	86.8	28.3	53.3	84.6	31.4	48.2	82.8	34.6	
	36	85.0	105	19.8	84.0	106	21.8	82.0	106	24.1	78.9	105	26.7	75.4	105	29.7	70.6	103	32.9	65.2	102	36.5	58.5	98.8	40.4	
	40	95.0	117	22.8	95.0	120	24.9	93.9	121	27.5	90.7	121	30.5	87.7	121	33.8	82.6	120	37.5	77.1	118	41.7	68.9	115	46.2	
	44	103	127	23.9	103	129	26.3	102.3	131	29.1	99.2	131	32.3	95.3	131	35.9	89.5	130	40.4	82.6	127	44.4	73.4	123	49.5	
4	32	87.2	104	16.6	84.9	104	18.5	82.2	103	20.7	79.0	102	23.0	74.9	101	25.6	70.4	98.9	28.4	65.4	96.8	31.4	60.2	94.9	34.6	
	36	97.1	117	19.8	95.9	118	21.9	93.9	118	24.2	91.0	118	27.0	87.3	117	29.9	82.7	116	33.1	77.2	114	36.7	70.8	111	40.7	
	40	107	130	23.0	107	132	25.2	106	133	27.8	103	134	30.9	99.7	134	34.1	94.9	133	37.8	89.0	131	41.9	81.4	128	46.8	
	44	115	140	24.5	115	142	26.9	114	144	29.7	111	144	33.0	108	144	36.6	102	143	40.6	95.8	141	45.1	87.6	137	50.1	
7	32	92.9	110	17.3	91.7	111	19.0	89.5	111	21.0	86.0	110	23.6	81.9	108	25.7	76.6	105	28.4	70.2	102	31.4	62.3	97	35.1	
	36	104	124	20.2	104	126	22.2	102	127	24.5	99.0	126	27.3	95.3	125	30.1	90.3	124	33.1	84.2	121	36.8	76.4	117	40.6	
	40	116	139	23.2	116	141	25.4	115	142	28.0	112	143	31.0	109	143	34.4	104	142	37.8	98.2	140	42.3	90.6	137	46.6	
	44	124	149	24.7	124	151	27.2	123	153	30.0	121	154	33.1	117	154	36.9	112	153	40.7	105	151	45.5	96.6	146	50.1	
10	32	98.2	116	17.2	97.4	117	19.0	95.9	117	21.1	93.1	117	23.5	89.2	115	26.0	84.1	113	28.7	77.8	110	31.8	70.1	105	35.1	
	36	110	130	20.2	109	132	22.2	108	133	24.6	106	133	27.3	103	133	30.2	98.0	131	33.4	92.2	129	37.0	84.9	126	41.0	
	40	122	145	23.2	121	147	25.4	121	149	28.1	119	150	31.1	116	150	34.4	112	150	38.1	107	149	42.3	99.6	146	46.8	
	44	130	156	24.9	130	159	27.4	129	161	30.2	127	162	33.4	124	162	37.1	119	161	41.1	113	160	45.5	105	156	50.2	
14	32	105	123	17.1	105	124	19.1	104	126	21.2	103	126	23.3	99.0	125	26.2	94.1	123	29.1	87.8	120	32.3	80.6	116	35.1	
	36	117	137	20.2	117	139	22.3	117	141	24.6	115	142	27.2	112	143	30.3	108	142	33.6	103	140	37.2	96.1	137	41.0	
	40	129	152	23.2	129	154	25.5	129	157	28.1	128	159	31.2	126	160	34.4	123	161	38.1	118	160	42.2	112	158	46.9	
	44	141	167	25.0	141	169	27.5	140	171	30.4	139	172	33.7	136	173	37.2	132	173	41.1	126	172	45.4	120	170	50.3	
16	32	109	126	17.1	108	128	19.0	108	129	21.1	106	130	23.3	103	129	26.1	98.7	128	29.0	92.8	125	32.2	85.7	121	35.1	
	36	120	140	20.2	119	142	22.3	119	144	24.7	118	145	27.3	116	146	30.4	112	146	33.7	107	144	37.3	101	142	41.0	
	40	131	154	23.2	130	156	25.6	130	158	28.2	129	161	31.3	128	162	34.6	125	163	38.3	121	163	42.4	116	163	46.9	
	44	143	170	25.1	143	172	27.6	142	174	30.5	141	176	33.8	138	177	37.3	135	178	41.3	130	177	45.6	124	176	50.4	
20	32	115	132	17.0	115	134	18.9	115	136	21.0	114	137	23.2	112	138	26.0	108	137	28.9	103	135	32.0	95.7	131	35.0	
	36	124	144	20.1	124	146	22.3	124	149	24.8	123	151	27.3	122	152	30.4	119	153	33.8	115	152	37.4	110	151	41.0	
	40	133	156	23.3	133	159	25.7	133	161	28.5	133	164	31.5	132	167	34.9	130	168	38.6	127	170	42.7	124	171	47.0	
	44	151	176	25.1	151	179	27.7	151	181	30.7	150	184	34.0	149	186	37.5	146	188	41.5	142	188	45.7	137	187	50.6	
48	169	196	26.9	169	199	29.7	168	201	32.9	168	205	36.6	166	206	40.1	162	207	44.3	157	205	48.8	150	203	54.2		

4TW53472-3C

SYMBOLS

- CC : Cooling capacity (kW)
- HC : Heating capacity (kW)
- PI : Power input (kW)
- LWE : Leaving water evaporator (°C)
- LWC : Leaving water condenser (°C)

4 Capacity tables

4 - 1 Cooling/Heating Capacity Tables

LWC	MODEL	20			25			30			35			40			45			50			55		
		CC	HC	PI	CC	HC	PI	CC	HC	PI	CC	HC	PI	CC	HC	PI	CC	HC	PI	CC	HC	PI	CC	HC	PI
-10	52	82,4	108	25,9	81,6	110	29,0	78,2	110	32,4	73,4	109	36,2	67,5	107	40,3	60,4	105	44,8	-	-	-	-	-	-
	56	90,5	119	29,2	90,2	122	32,6	87,4	123	36,4	82,8	123	40,7	76,7	122	45,4	69,1	119	50,5	-	-	-	-	-	-
	60	98,6	130	32,5	98,8	134	36,2	96,6	136	40,5	92,1	137	45,2	85,8	136	50,5	77,8	133	56,3	-	-	-	-	-	-
	64	108	141	34,0	107	145	37,6	106	147	41,9	101	147	46,8	93,7	145	52,3	84,4	142	58,6	-	-	-	-	-	-
	68	117	152	35,5	116	155	39,0	115	157	43,3	109	157	48,4	102	155	54,2	91,0	151	60,8	-	-	-	-	-	-
	72	126	163	37,0	125	165	40,4	123	169	44,7	118	168	49,9	109	165	56,0	97,6	160	63,1	-	-	-	-	-	-
-5	52	104	131	27,1	102	131	30,2	98	132	33,6	93	130	37,5	88	129	41,6	80,7	127	46,2	72,6	123	51,1	-	-	-
	56	112	142	30,3	111	144	33,6	109	146	37,4	103	145	41,7	98	144	46,3	90,9	142	51,5	82,5	139	57,1	-	-	-
	60	121	154	33,6	121	157	37,1	119	160	41,2	113	159	45,8	109	159	51,0	101	157	56,8	92,5	155	63,1	-	-	-
	64	129	164	35,0	129	167	38,5	128	170	42,7	122	169	47,5	117	169	53,0	108	167	59,2	97,6	163	65,8	-	-	-
	68	138	174	36,4	137	177	39,9	136	180	44,2	131	180	49,2	124	179	54,9	115	176	61,6	103	171	68,5	-	-	-
	72	146	184	37,8	146	187	41,3	145	190	45,7	140	190	50,8	132	189	56,8	121	185	64,0	108	178	71,2	-	-	-
0	52	122	150	28,3	121	151	31,1	117	151	34,5	112	151	38,2	107	149	42,5	100	147	47,1	91,8	144	52,2	82,6	140	57,7
	56	132	163	31,2	132	165	34,3	129	166	37,9	124	166	42,0	119	166	46,6	112	163	51,7	104	161	57,4	93,0	156	63,5
	60	143	176	34,2	143	180	37,4	141	182	41,2	136	181	45,7	132	182	50,7	124	180	56,3	116	178	62,5	103	172	69,3
	64	151	186	35,3	151	189	38,8	149	192	42,8	145	192	47,5	139	192	52,8	131	190	59,1	121	186	65,3	108	180	72,6
	68	159	196	36,5	159	199	40,2	158	202	44,4	153	202	49,4	147	201	55,0	138	199	61,9	127	194	68,0	112	188	76,0
	72	168	206	37,6	167	209	41,5	166	212	46,0	162	213	51,2	154	211	57,1	145	209	64,7	132	202	70,8	117	195	79,3
4	52	141	169	28,1	138	169	31,1	135	170	34,6	131	169	38,5	125	167	42,7	118	165	47,3	110	162	52,3	101	159	58,0
	56	151	182	31,3	149	184	34,4	147	185	38,1	143	185	42,4	137	184	46,9	130	182	52,0	122	179	57,6	112	176	64,1
	60	160	195	34,5	160	198	37,8	159	200	41,7	155	201	46,4	150	200	51,2	142	199	56,8	134	196	62,9	122	192	70,2
	64	169	205	36,0	168	208	39,5	167	210	43,6	163	211	48,4	158	211	53,6	150	209	59,5	140	206	66,0	128	201	73,5
	68	177	215	37,4	176	218	41,2	175	221	45,5	171	222	50,5	166	222	56,1	157	220	62,3	147	216	69,2	134	211	76,7
	72	185	225	38,9	184	228	42,9	183	231	47,4	180	233	52,6	174	232	58,5	165	230	65,1	154	226	72,3	141	220	79,9
7	52	151	180	28,9	150	181	31,7	147	182	35,0	142	181	39,1	136	179	42,9	129	178	47,3	119	172	52,5	108	166	58,4
	56	162	194	31,8	162	196	34,9	159	198	38,5	155	198	42,8	150	197	47,3	142	195	52,0	133	191	57,9	122	186	64,1
	60	174	208	34,8	174	212	38,1	172	214	42,0	166	214	46,9	163	214	51,6	156	213	56,7	147	210	63,4	136	206	69,9
	64	182	218	36,3	182	222	39,9	181	225	44,0	177	226	48,9	172	226	54,1	164	224	59,6	154	221	66,6	142	215	73,3
	68	190	228	37,9	190	232	41,7	189	235	46,0	185	237	50,7	181	237	56,6	172	235	62,5	162	231	69,8	148	224	76,8
	72	199	238	39,4	198	242	43,4	198	246	48,0	193	248	52,8	189	248	59,1	180	246	65,4	169	241	73,0	154	234	80,3
10	52	159	188	28,8	158	190	31,8	156	191	35,1	153	191	39,0	147	190	43,2	140	188	47,8	131	184	52,9	120	178	58,5
	56	171	202	31,8	170	205	35,0	169	207	38,6	165	208	42,8	161	208	47,4	154	206	52,5	146	204	58,1	135	199	64,4
	60	183	217	34,8	182	220	38,2	181	223	42,1	178	225	46,6	174	226	51,6	168	225	57,2	160	223	63,4	149	219	70,3
	64	191	229	36,5	190	232	40,1	189	235	44,2	186	237	49,0	182	237	54,3	175	236	60,2	166	234	66,6	155	230	73,7
	68	199	241	38,2	198	244	42,0	197	247	46,4	194	249	51,3	189	249	56,9	182	248	63,1	172	245	69,9	160	240	77,1
	72	207	252	39,9	207	256	44,0	206	259	48,5	202	261	53,6	197	261	59,6	188	259	66,0	178	256	73,1	165	250	80,5
14	52	170	199	28,7	170	201	31,8	169	204	35,2	167	208	38,9	162	205	43,4	155	204	48,2	147	200	53,4	136	195	58,5
	56	182	214	31,8	182	216	35,0	181	220	38,7	179	222	42,8	175	223	47,5	170	222	52,7	162	220	58,3	152	216	64,4
	60	194	229	34,8	194	232	38,2	193	235	42,1	192	238	46,8	189	240	51,6	184	241	57,2	177	240	63,3	167	238	70,4
	64	206	243	36,6	206	246	40,2	205	249	44,4	203	252	49,3	199	253	54,4	193	253	60,2	185	252	66,5	176	249	73,7
	68	218	257	38,5	218	260	42,3	216	263	46,7	214	265	51,8	209	266	57,2	202	265	63,2	194	263	69,8	184	260	77,1
	72	230	271	40,3	230	275	44,4	228	277	49,0	225	279	54,3	219	279	59,9	211	277	66,2	202	275	73,0	192	272	80,5
16	52	174	203	28,7	174	205	31,8	173	208	35,2	171	210	38,9	167	211	43,4	161	209	48,2	153	207	53,4	144	202	58,5
	56	185	217	31,8	185	219	35,1	184	223	38,8	183	225	42,9	179	227	47,7	174	227	52,8	167	226	58,5	159	223	64,5
	60	196	231	34,8	196	234	38,3	195	237	42,3	194	241	46,9	192	243	51,9	187	245	57,5	182	245	63,6	174	244	70,4
	64	208	247	36,7	208	250	40,4	207	253	44,6	206	257	49,5	202	259	54,6	197	259	60,4	190	259	66,8	182	257	73,9
	68	221	263	38,6	220	266	42,5	219	269	46,9	217	272	52,0	213	274	57,4	207	274	63,4	199	272	70,0	190	270	77,4
	72	233	279	40,4	232	283	44,5	231	286	49,2	228	288	54,6	224	289	60,1	217	288	66,4	208	286	73,2	198	283	80,8
20	52	182	211	28,6	182	213	31,8	181	216	35,3	180	219	38,9	178	221	43,4	173	221	48,2	167	220	53,4	158	216	58,5
	56	191	222	31,8	191	226	35,2	190	229	39,0	190	233	43,1	188	235	47,9	184	237	53,1	179	237	58,7	172	236	64,5
	60</																								

4 Capacity tables

4 - 2 Capacity Correction Factor

Required glycol concentration

Type	Concentration (wt%)	0	10	20	30	40
Ethylene glycol	Freezing point °C	0	-4	-9	-16	-23
	Minimum LWE °C	4	2	0	-5	-11
Propylene glycol	Freezing point °C	0	-3	-7	-13	-22
	Minimum LWE °C	4	3	-2	-4	-10

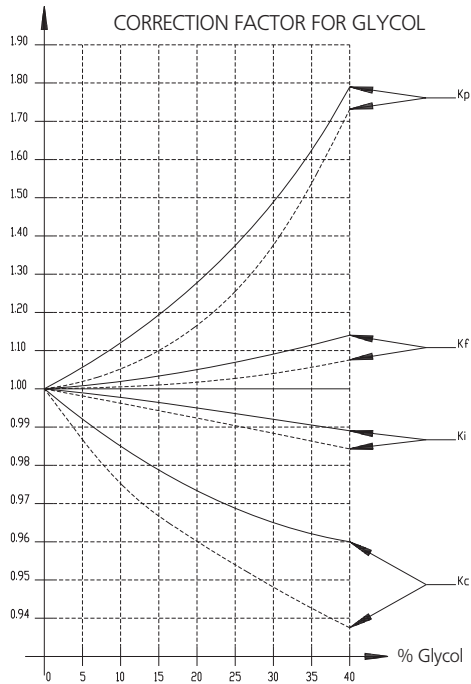

Legend
 — Ethylene glycol
 - - - Propylene glycol
 Kc Correction on cooling capacity
 Ki Correction on power input
 Kf Correction on flow rate
 Kp Correction on pressure drop

4TW54179-1

5 Dimensional drawings

5 - 1 Dimensional Drawings

EWWP014-035KBW1N

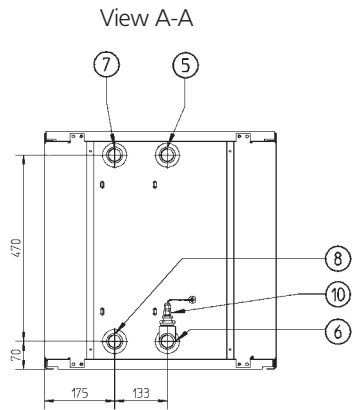
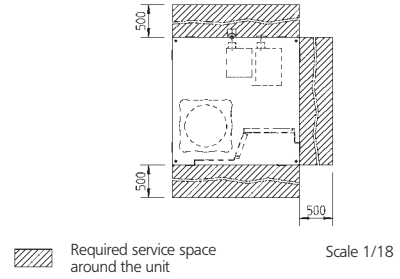
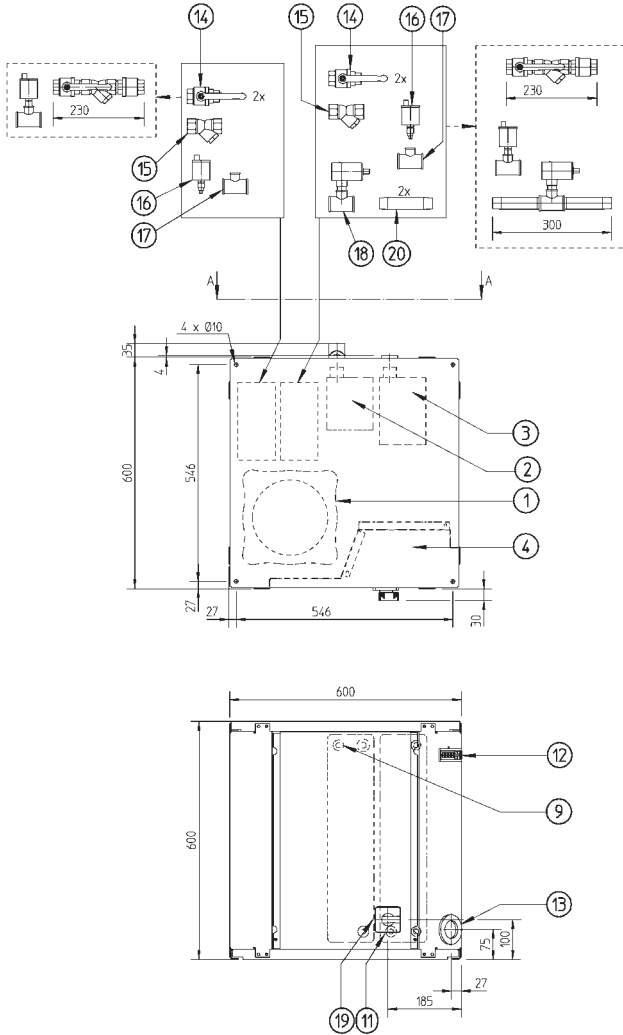

- | | |
|--|-------------------------------------|
| 1 Compressor | 12 Digital display controller |
| 2 Evaporator | 13 Power supply intake (ϕ 48) |
| 3 Condenser | 14 Ballvalve |
| 4 Switchbox | 15 Water filter |
| 5 Chilled water in | 16 Air purge |
| 6 Chilled water out | 17 T-joint for air purge |
| 7 Condenser water out | 18 Flow switch |
| 8 Condenser water in | 19 Main switch |
| 9 Evaporator entering water temperature sensor | 20 Flow switch pipe |
| 10 Freeze up sensor | |
| 11 Condensor entering water temperature sensor | |

3TW55254-1B

5 Dimensional drawings

5 - 1 Dimensional Drawings

EWWP045-065KBW1N

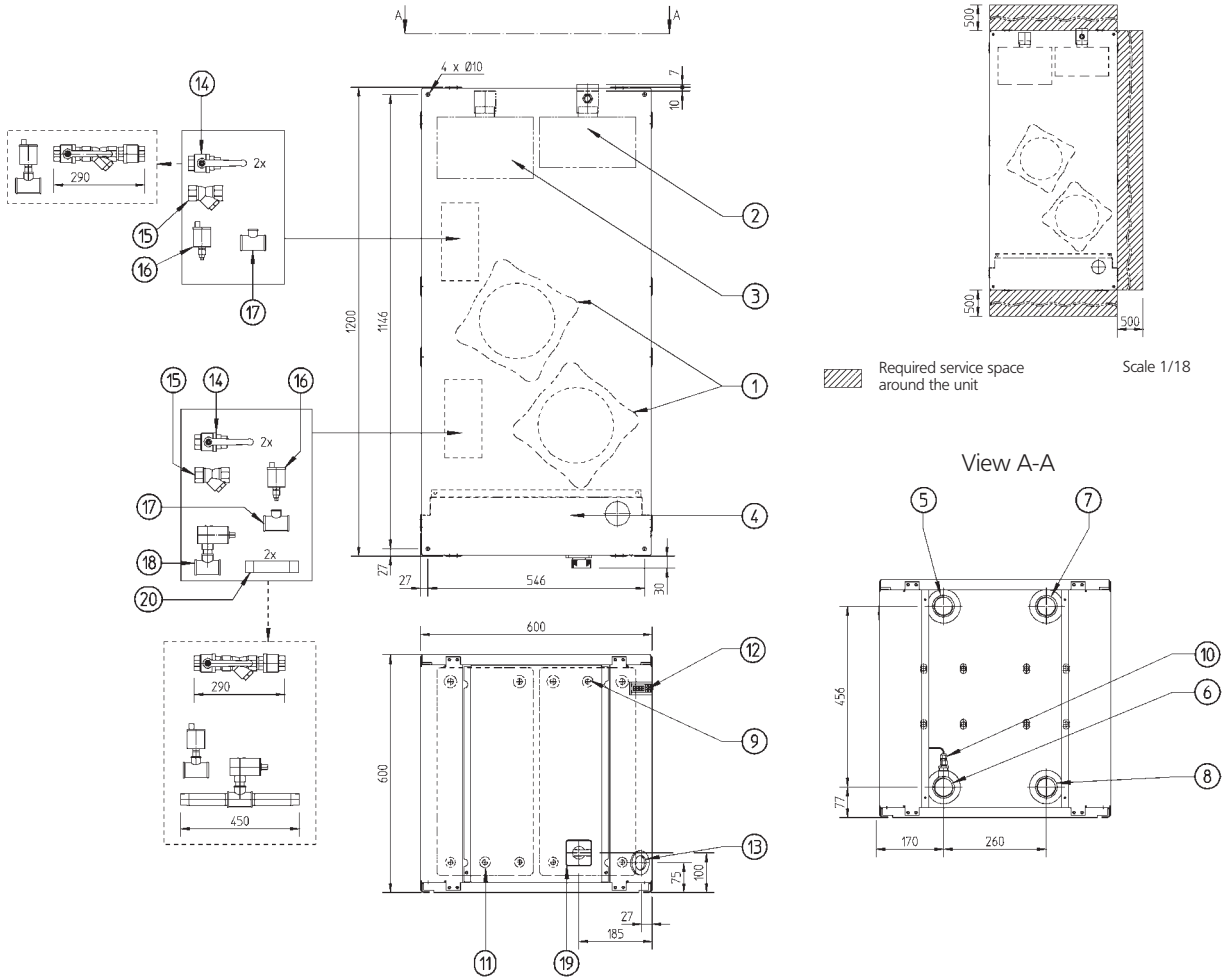

- | | |
|--|-------------------------------------|
| 1 Compressor | 12 Digital display controller |
| 2 Evaporator | 13 Power supply intake (ϕ 48) |
| 3 Condenser | 14 Ballvalve |
| 4 Switchbox | 15 Water filter |
| 5 Chilled water in | 16 Air purge |
| 6 Chilled water out | 17 T-joint for air purge |
| 7 Condenser water out | 18 Flow switch |
| 8 Condenser water in | 19 Main switch |
| 9 Evaporator entering water temperature sensor | 20 Flow switch pipe |
| 10 Freeze up sensor | |
| 11 Condenser entering water temperature sensor | |

3TW55304-1B

5 Dimensional drawings

5 - 1 Dimensional Drawings

EWWP090-130KBW1N (32-48hp)

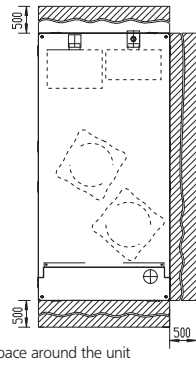
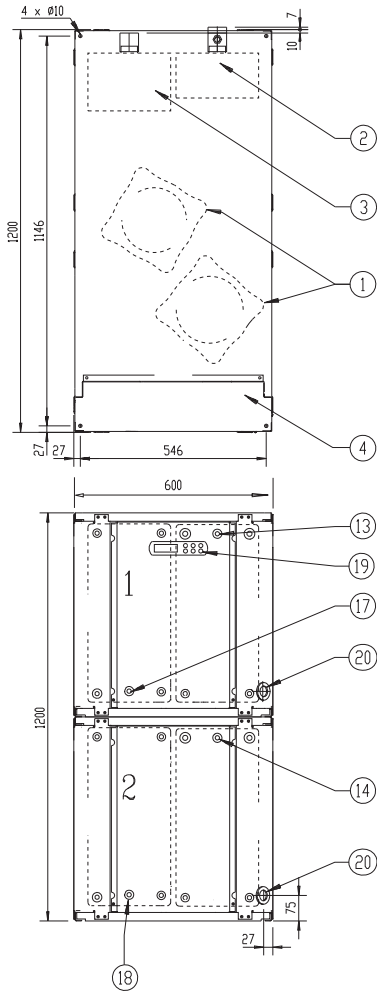

Required service space around the unit

Scale 1/18

backside

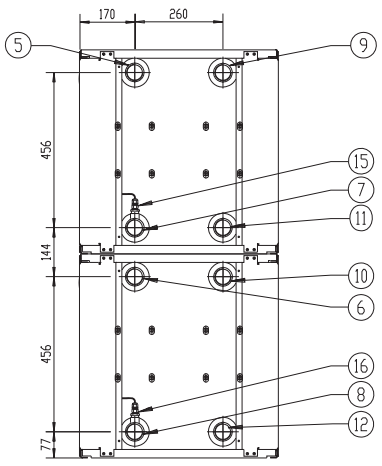

- | | |
|---|--|
| <ul style="list-style-type: none"> 1 Compressor 2 Evaporator 3 Condenser 4 Switchbox 5 Chilled water in 1 6 Chilled water in 2 7 Chilled water out 1 8 Chilled water out 2 9 Condenser water out 1 10 Condenser water out 2 11 Condenser water in 1 12 Condenser water in 2 | <ul style="list-style-type: none"> 13 Evaporator entering water temperature sensor 1 14 Evaporator entering water temperature sensor 2 15 Freeze up sensor 1 16 Freeze up sensor 2 17 Condenser entering water temperature 1 18 Condenser entering water temperature 2 19 Digital display controller 20 Power supply intake (φ 48) |
|---|--|

5 Dimensional drawings

5 - 1 Dimensional Drawings

EWWP145-195KBW1N (52-72hp)

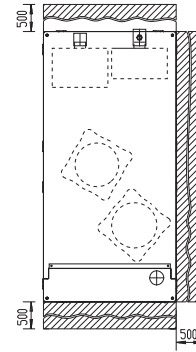
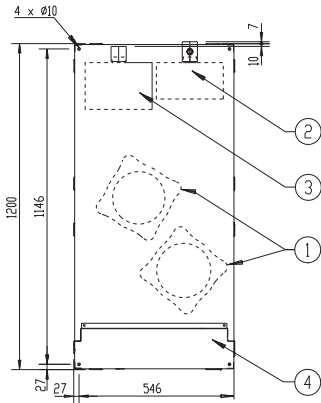

Required service space around the unit

Scale 1/18

backside

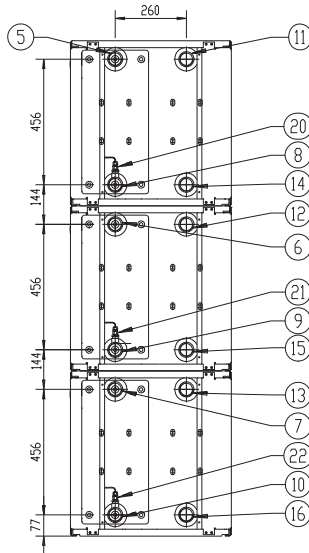
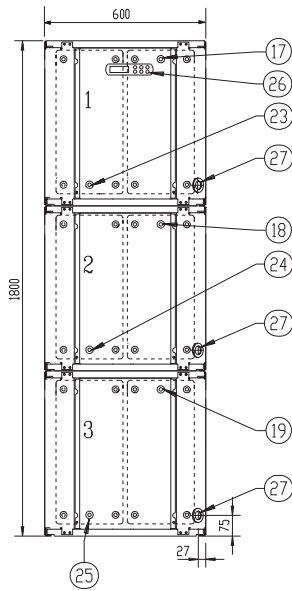

- | | |
|---|---|
| <ul style="list-style-type: none"> 1 Compressor 2 Evaporator 3 Condenser 4 Switchbox 5 Chilled water in 1 6 Chilled water in 2 7 Chilled water in 3 8 Chilled water out 1 9 Chilled water out 2 10 Chilled water out 3 11 Condenser water out 1 12 Condenser water out 2 13 Condenser water out 3 14 Condenser water in 1 15 Condenser water in 2 16 Condenser water in 3 | <ul style="list-style-type: none"> 17 Evaporator entering water temperature sensor 1 18 Evaporator entering water temperature sensor 2 19 Evaporator entering water temperature sensor 3 20 Freeze up sensor 1 21 Freeze up sensor 2 22 Freeze up sensor 3 23 Condenser entering water temperature 1 24 Condenser entering water temperature 2 25 Condenser entering water temperature 3 26 Digital display controller 27 Power supply intake (φ 48) |
|---|---|

3TW53474-4B

6 Centre of gravity

6 - 1 Centre of Gravity

1
6

EWWP014-035KBW1N

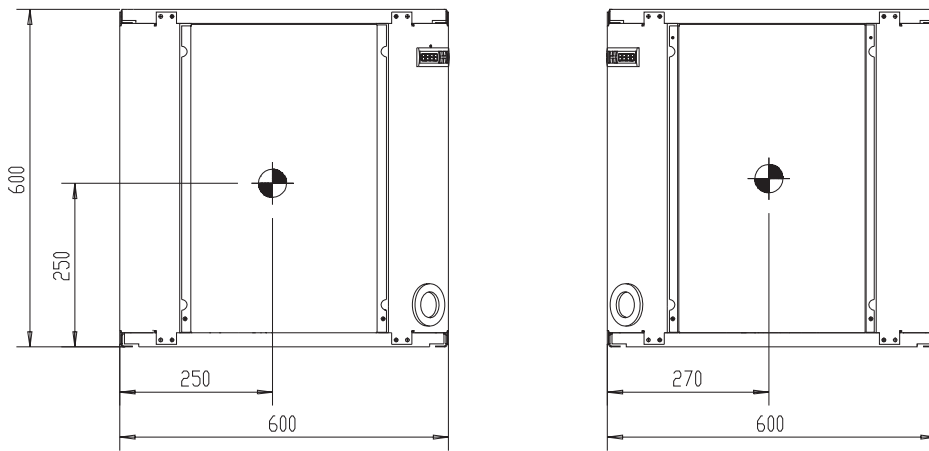

4TW53479-2

EWWP045-065KBW1N

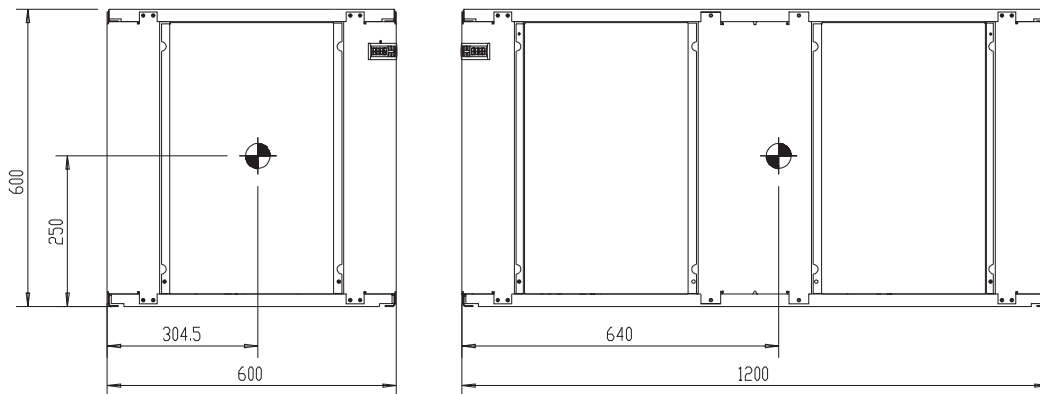

4TW53479-3

6 Centre of gravity

6 - 1 Centre of Gravity

EWWP090-130KBW1N (32-48hp)

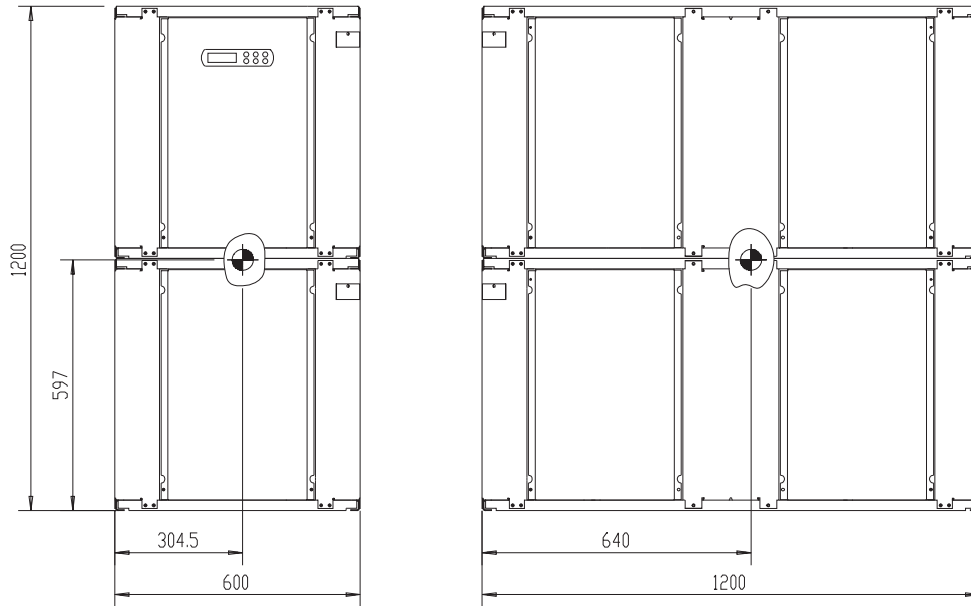

4TW53479-4

EWWP145-195KBW1N (52-72hp)

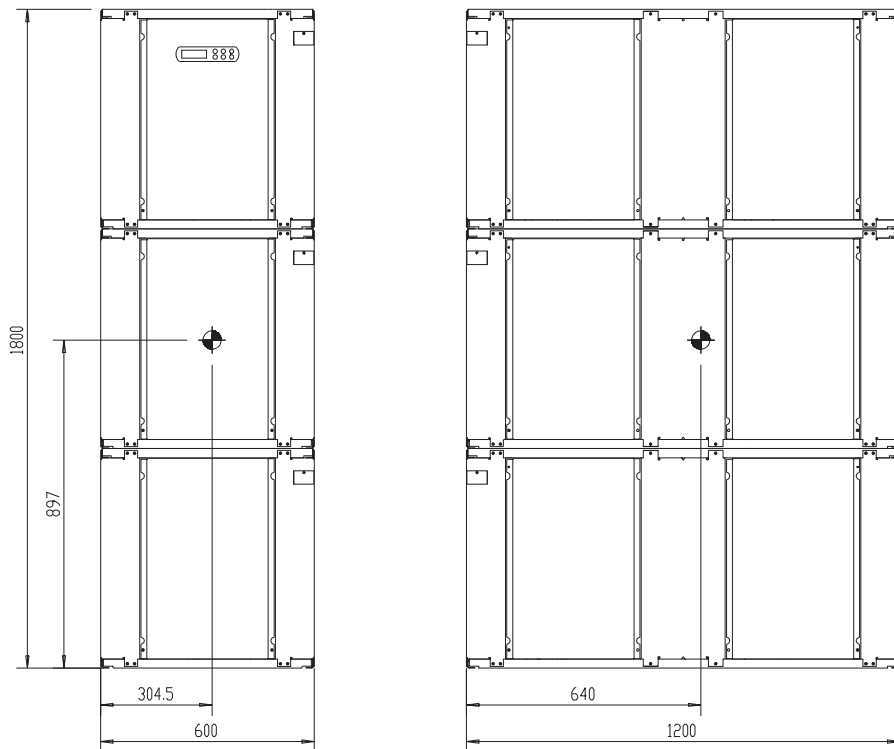

4TW53479-5

7 Piping diagrams

7 - 1 Piping Diagrams

EWWP014-035KBW1N

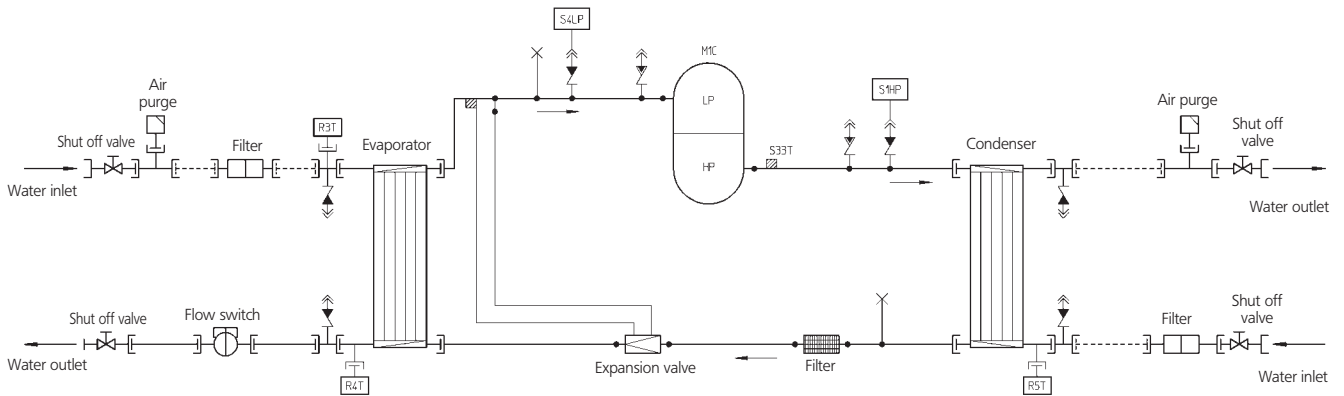

- M1C Compressor motor 1
- R3T Outlet water evap. temp. sensor
- R5T Inlet water cond. temp. sensor
- S1HP High pressure switch
- S4LP Low pressure switch
- R4T Freeze-up protection
- S33T Discharge temperature controller

- Field piping
- ↔ Check valve
- ↖ Flare connection
- ⊞ Screw connection
- ⊞ Flange connection
- ✕ Pinched pipe
- Spinned pipe

3TW55255-1B

1
7

7 Piping diagrams

7 - 1 Piping Diagrams

EWWP045-065KBW1N

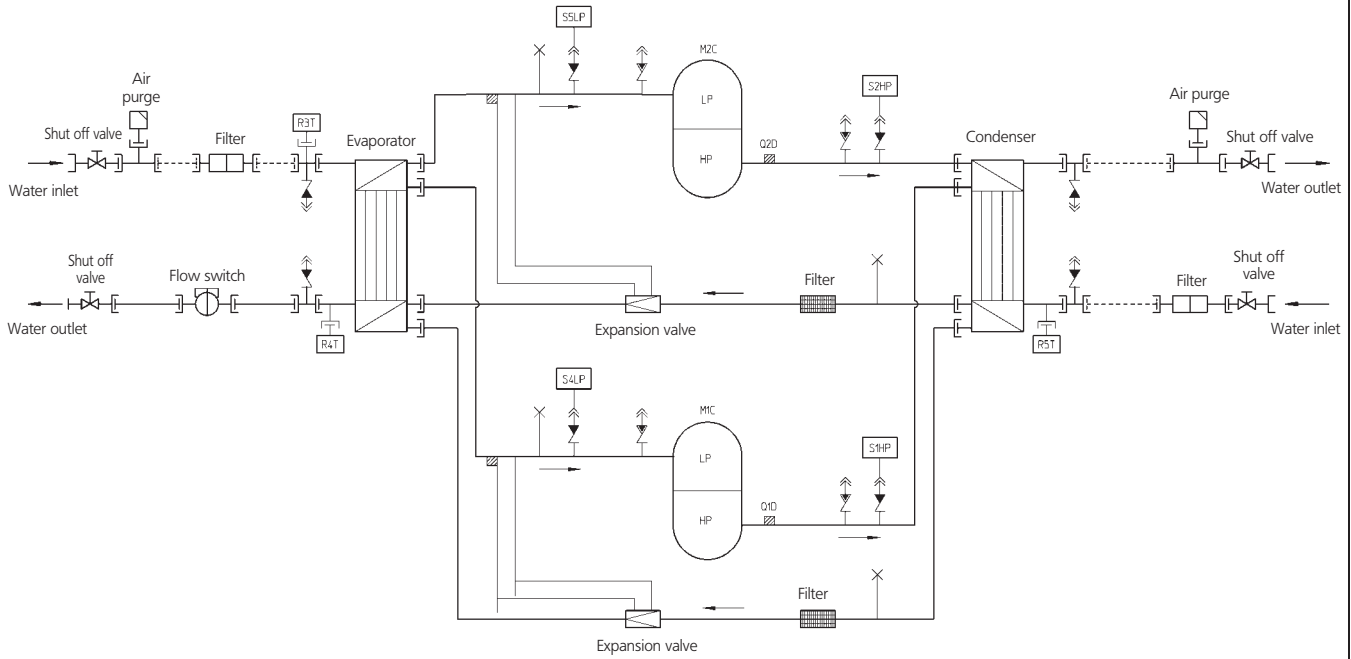

- M1-2C Compressor motor
- R4T Freeze-up protection
- R5T Inlet water cond. temp. sensor
- S1HP High pressure switch
- S2HP High pressure switch
- S4LP Low pressure switch
- S5LP Low pressure switch
- R3T Inlet water evap. temp. sensor
- Q1D Discharge temperature controller
- Q2D Discharge temperature controller

- Field piping
- ↔ Check valve
- ↔ Flare connection
- ⊞ Screw connection
- ⊞ Flange connection
- ✕ Pinched pipe
- Spinned pipe

3TW55305-1B

7 Piping diagrams

7 - 1 Piping Diagrams

EWWP090-130KBW1N (32-48hp)

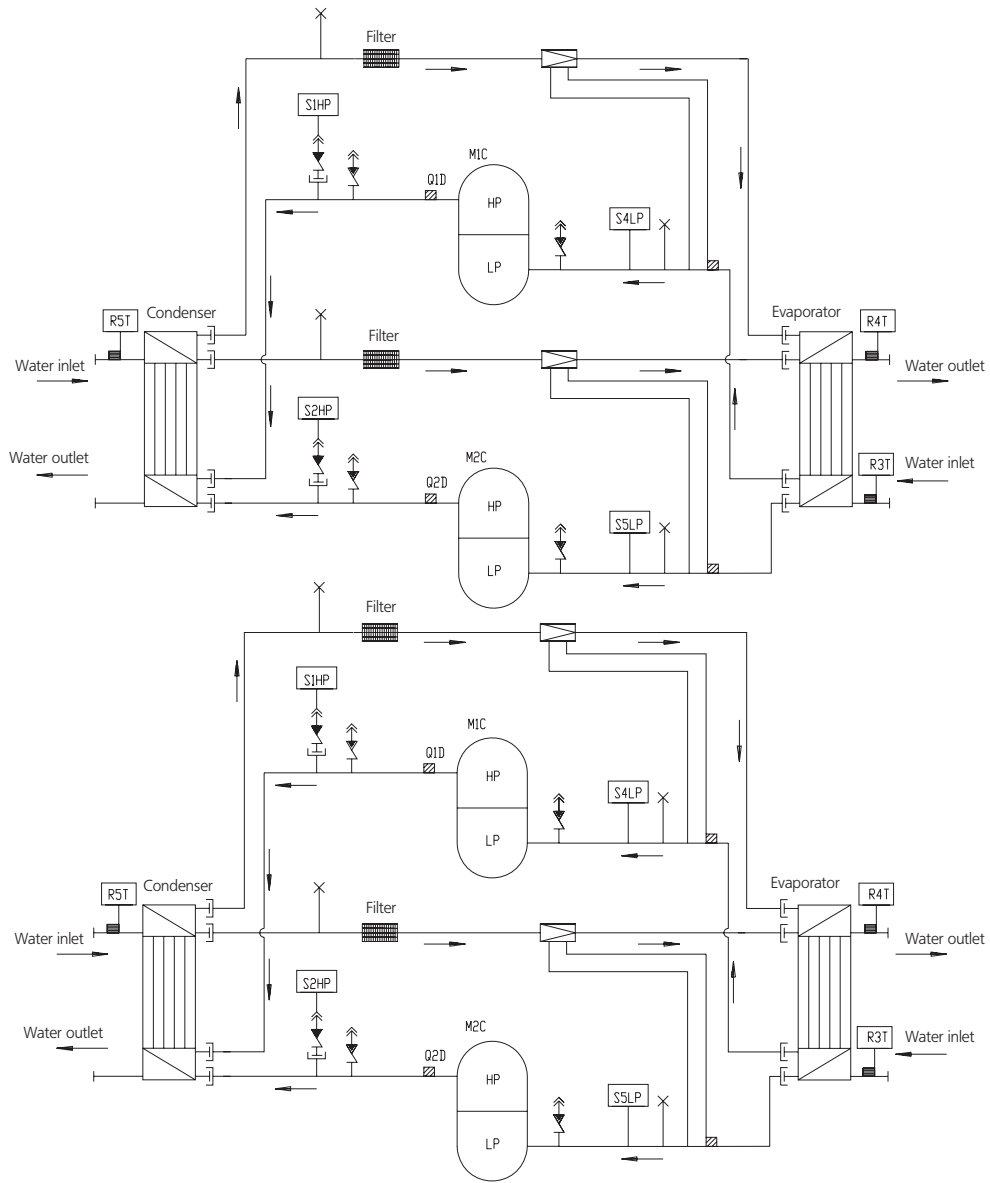

- M1C-M2C Compressor motor
- R4T Freeze-up protection
- R5T Inlet water cond. temp. sensor
- S1HP High pressure switch
- S2HP High pressure switch
- S4LP Low pressure switch
- S5LP Low pressure switch
- R3T Inlet water evap. temp. sensor
- Q1D Discharge temperature controller
- Q2D Discharge temperature controller

- ↔ Check valve
- ↔ Flare connection
- ⊥ Screw connection
- ⊥ Flange connection
- ✕ Pinched pipe
- Spinned pipe

3TW53475-3

7 Piping diagrams

7 - 1 Piping Diagrams

EWWP145-195KBW1N (52-72hp)

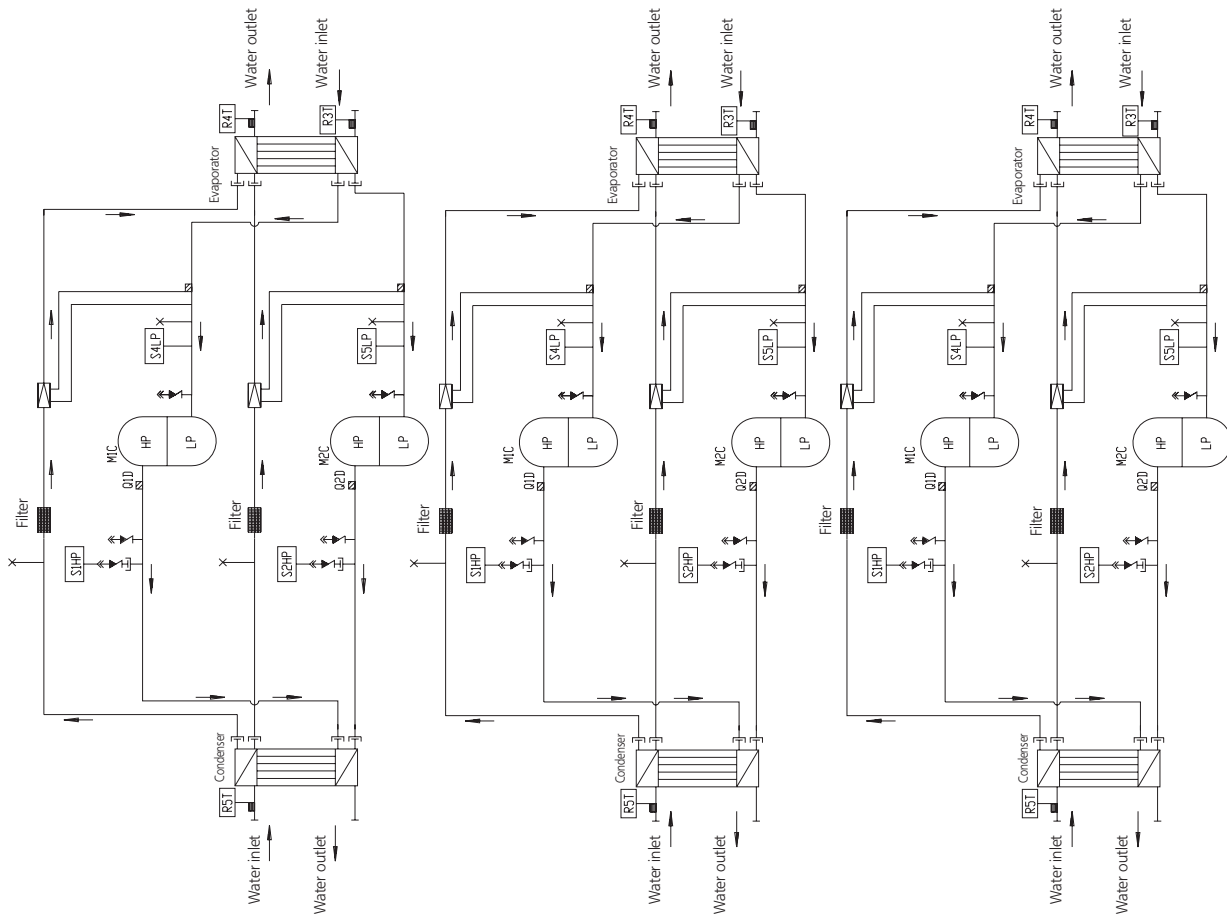

- M1C-M2C Compressor motor
- R4T Freeze-up protection
- R5T Inlet water cond. temp. sensor
- S1HP High pressure switch
- S2HP High pressure switch
- S4LP Low pressure switch
- S5LP Low pressure switch
- R3T Inlet water evap. temp. sensor
- Q1D Discharge temperature controller
- Q2D Discharge temperature controller

- ↔ Check valve
- ↪ Flare connection
- ⊞ Screw connection
- ⊞ Flange connection
- ✕ Pinched pipe
- Spinned pipe

3TW53475-4

8 Wiring diagrams

8 - 1 Wiring Diagrams - Three Phase

EWWP-KBW1N EWLP-KBW1N

	Not standard included	
	Not possible as option	Possible as option
Obligatory	#	##
Not obligatory	*	**

A2P	A1P
DIGITAL INPUTS	DIGITAL INPUTS
D11 Reverse phase detection (L1-N)	X1 (ID1-GND) : Flow switch
D12 Reverse phase detection (N-L3)	X1 (ID2-GND) : Remote C/H selection
D13 M1C ON detection	X1 (ID3-GND) : High pressure switch + discharge protector + overcurrent
D14 M2C ON detection	X1 (ID4-GND) : Low pressure switch
D15 Safety device detection	X1 (ID5-GND) : Remote On/Off
D16 Pump ON detection	
D17 --	
D18 --	
D19 --	
D110 Reverse valve request	DIGITAL OUTPUTS (RELAYS)
	X2 (C1/2-NO1) : Compressor M1C on
	X2 (C1/2-NO2) : Compressor M2C on
	X2 (C3/4-NO3) : Voltage free contact for pump
	X2 (C3/4-NO4) : Reversing valve
	X2 (C5-NO5) : Alarm voltage free contact
DIGITAL OUTPUTS (RELAYS)	
RY1 Reversed phase protector	
RY3 Pump/general operation	
RY9 M1C off (during defrost)	
RY10 M2C off (during defrost)	
	ANALOG INPUTS
	X1 (B1-GND) : evap. inlet water t°
	X1 (B2-GND) : evap. outlet water t°
	X1 (B3-GND) : cond. inlet water t°
OTHERS	
HAP Light emitting diode (service monitor green)	
H1P,H2P Light emitting diode (service monitor red)	
S1A Dipswitch (unit setting)	
S2A Dipswitch (defr. & fan setting)	
	ANALOG OUTPUTS
	X1 (Y-GND)

	All models (400V)						
Fuses + overcurrent	WC014 RC012	WC022 RC020	WC028 RC026	WC035 RC030	WC045 RC040	WC055 RC055	WC065 RC065
F1,F2,F3 (=gL/gG)	3x16A	3x20A	3x25A	3x32A	3x40A	3x50A	3x50A
F4	8A	8A	8A	8A	8A	8A	8A
F5	250mAT	250mAT	250mAT	250mAT	250mAT	250mAT	250mAT
F1U	5A	5A	5A	5A	5A	5A	5A
F3U	315mAT	315mAT	315mAT	315mAT	315mAT	315mAT	315mAT
K4S	9A	14.5A	18.5A	22A	14A	18A	20A
K5S	-	-	-	-	14A	18A	20A

Y3R *	Reverse valve of water circuit	R3T	Evaporator inlet water temperature sensor	F3U	Fuse controller PCB
Y1S,Y2S	Liquid solenoid valve circuit 1, circuit 2	Q1D,Q2D	Discharge thermal protector circuit 1, circuit 2	F1U	Fuse I/O PCB
X1-82(A/B/M)	Connectors	PE	Main earth terminal	F6 #	Fuse for pumpcontactor
TR2	Transfo 230V-24V for supply of I/O PCB	M1C,M2C	Compressor motor circuit 1, circuit 2	F5 # #	Surge proof fuse
TR1	Transfo 230V-24V for supply of controller PCB	K1P *	Pump contactor	F4	Fuse I/O PCB
S12M	Main isolator switch	K1F,K2F #	Fan contactor	F1,F2,F3 #	Main fuses for the unit
S10L	Flowswitch	K6S *	Overcurrent relay pump	E1H,E2H	Crankcase heater circuit 1, circuit 2
S9S *	Switch for remote start/stop or dual setpoint	K4S,K5S	Overcurrent relay circuit 1, circuit 2	A72P **	PCB: Power supply card
S7S *	Switch for remote cooling/heating selection or dual setpoint	K1M, K2M	Compressor contactor circuit 1, circuit 2	A71P **	PCB: Remote user interface
S4L,S5LP	Low pressure switch circuit 1, circuit 2	M1C,M2C	Compressor motor circuit 1, circuit 2	A3P **	PCB: Address card
S1HFS,ZHP	High pressure switch circuit 1, circuit 2	H6P *	Indication lamp general operation	A2P	PCB: I/O PCB
R5T	Condenser inlet water temperature sensor	H5P *	Indication lamp operation compressor 2	A1P	PCB: controller PCB
R4T	Evaporator outlet water temperature sensor	H4P *	Indication lamp operation compressor 1		
		H3P *	Indication lamp alarm		

NOTES

- Terminal 1, --- : Wire 2, --- : Field wiring to be in accordance with the local electrical regulations, --- : Earth wiring, □ : Option, ▨ : PCB, □ : outside switchbox
- If compressor rotates reversely, it may be damaged
- WC: Watercooled chiller
RC: Unit with remote condensor
- Optional:
- EKAC10C = Address card kit for Modbus or remote user interface connection
- EKSS = softstart
- EKRUCA = Remote user interface
- Terminals for fieldwiring
X1M: H3-6P,Y3R,K1-2F: output terminal for fieldwiring (voltage free contact max 2A / output)
X3M: S7S,S9S: Input terminal for fieldwiring (don't connect voltage)(switch load 6mA / 30VDC)
- Y3R is activated in cooling mode
S7S open = heating
S7S closed = cooling
- Dipswitch setting
S2A dipswitch: Defrost & Fan setting
no meaning for WC CO & WC CL CO

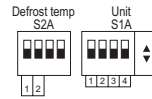

S1A dipswitch: Unit setting

- 1 > Off = 1 circuit
On = 2 circuit
234 > Off Off Off = WC CO & WC CL CO
Off On Off = AC CO
On Off Off = AC HP (without compr. stop for defrost cycle)
On Off On = AC HP (with compr. stop for defrost cycle)

7. Pump contact

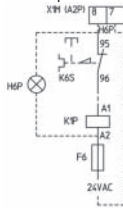

9 Sound data

9 - 1 Sound Power Spectrum

1
9

EWWP014-028KBW1N (5-10hp)

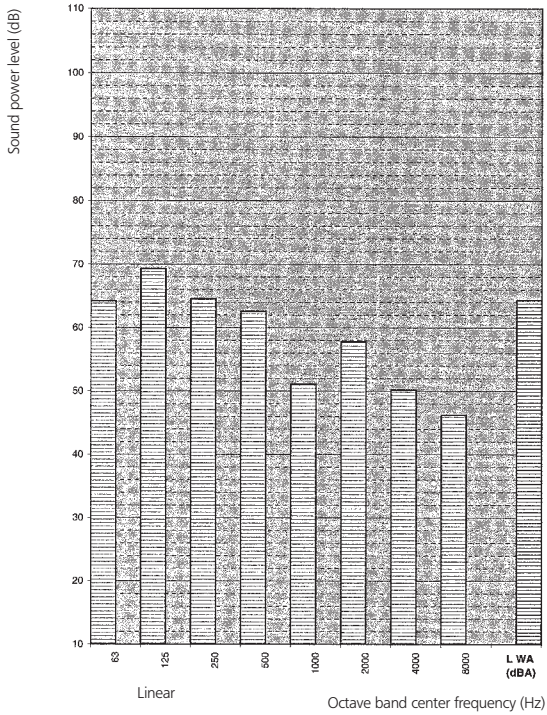

4TW57197-1

NOTES

Option low noise = -3dBa

EWWP035KBW1N (12hp)

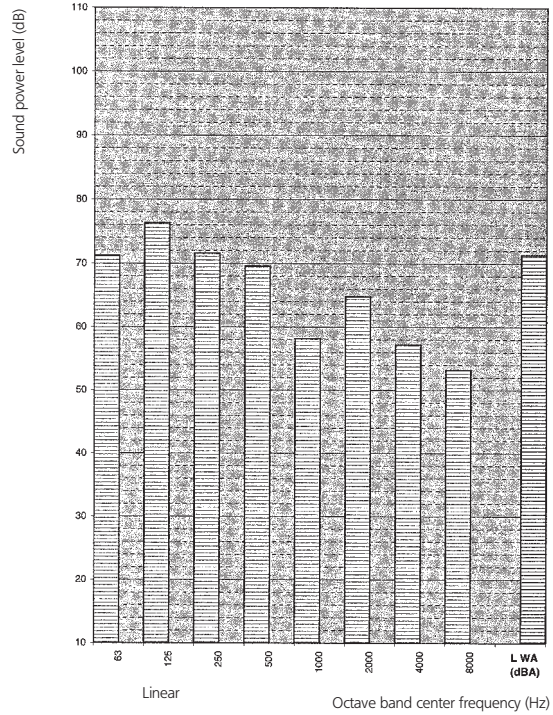

4TW57197-2

NOTES

Option low noise = -3dBa

EWWP045-055KBW1N (16-20hp)

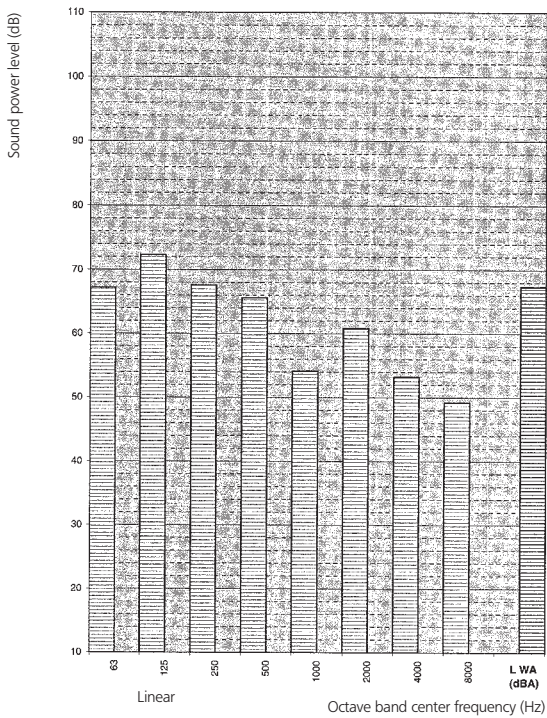

4TW57197-3

NOTES

Option low noise = -3dBa

EWWP065KBW1N (24hp)

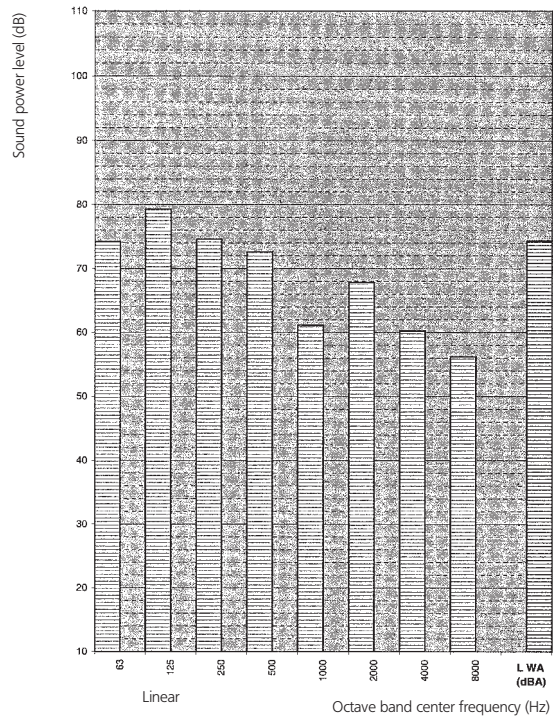

4TW57197-4

NOTES

Option low noise = -3dBa

9 Sound data

9 - 1 Sound Power Spectrum

EWWP090-110KBW1N (32-40hp)

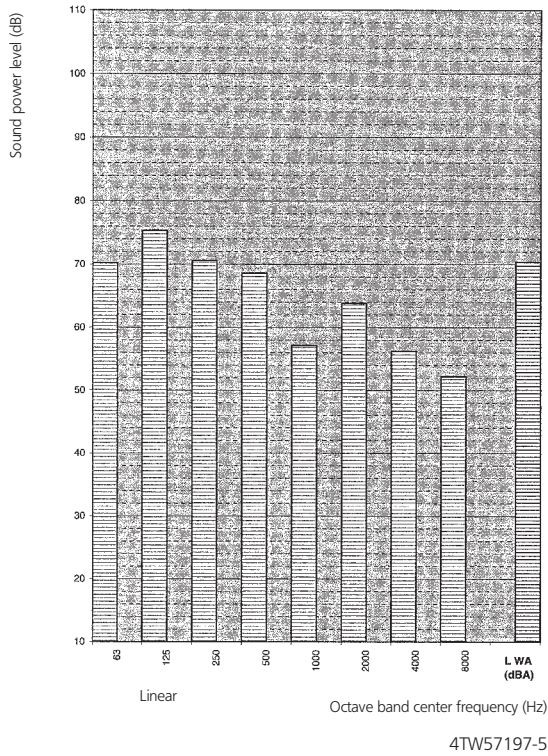

NOTES

Option low noise = -3dBA

EWWP120KBW1N (44hp)

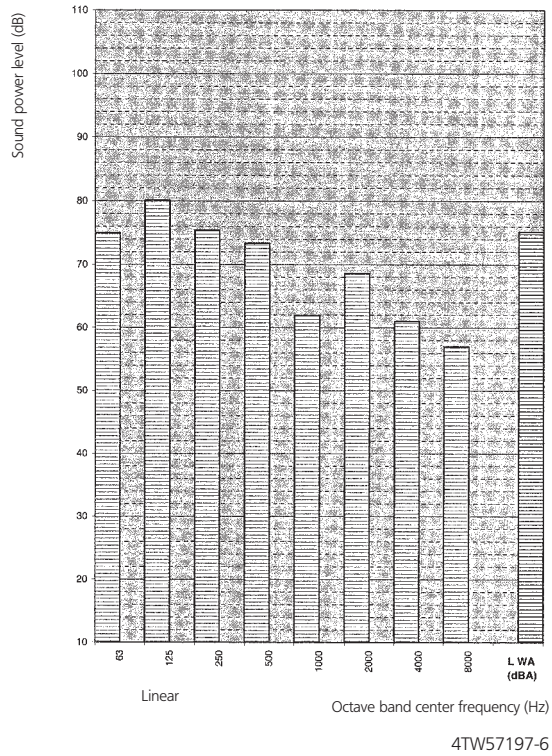

NOTES

Option low noise = -3dBA

EWWP130KBW1N (48hp)

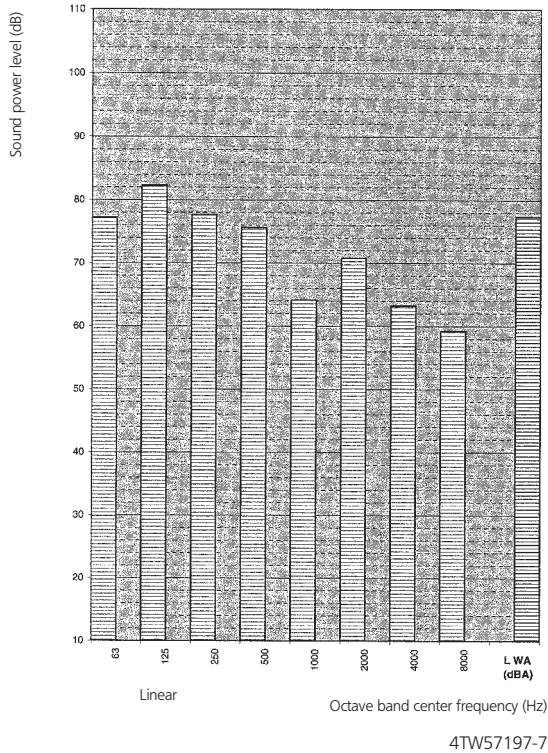

NOTES

Option low noise = -3dBA

EWWP145-165KBW1N (52-60hp)

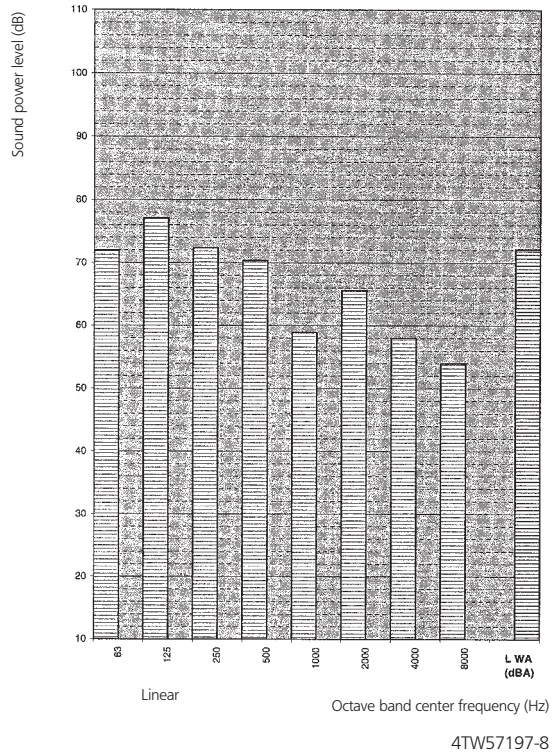

NOTES

Option low noise = -3dBA

9 Sound data

9 - 1 Sound Power Spectrum

1
9

EWWP175KBW1N (64hp)

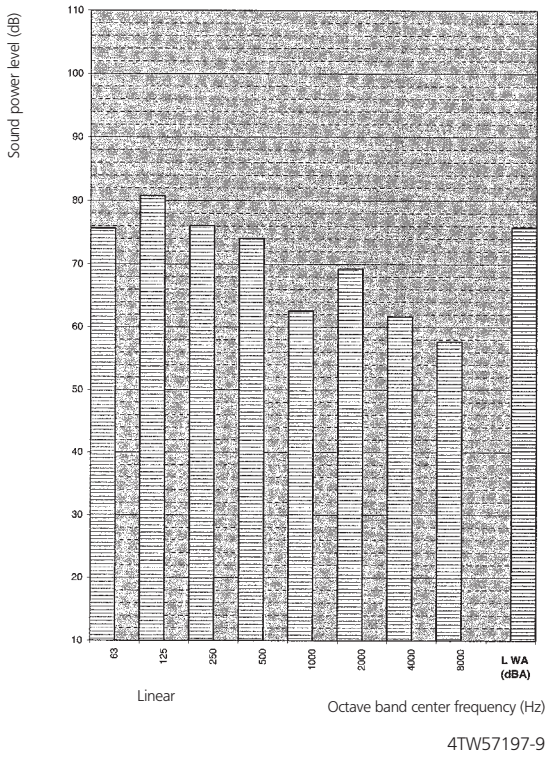

NOTES

Option low noise = -3dBa

EWWP185KBW1N (68hp)

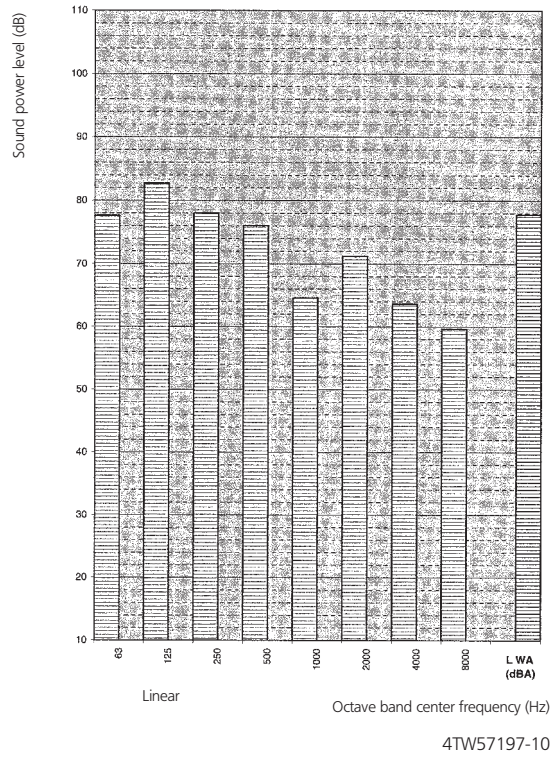

NOTES

Option low noise = -3dBa

EWWP195KBW1N (72hp)

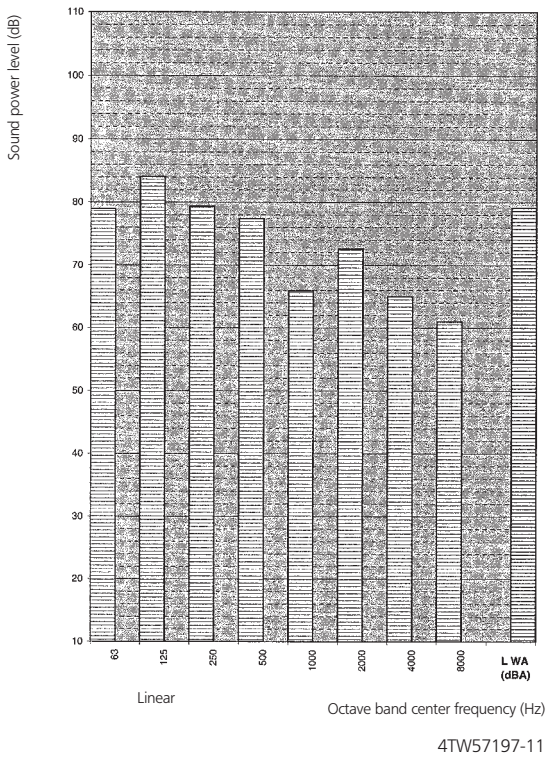

NOTES

Option low noise = -3dBa

10 Operation range

10 - 1 Operation Range

EWWP014-035KBW1N

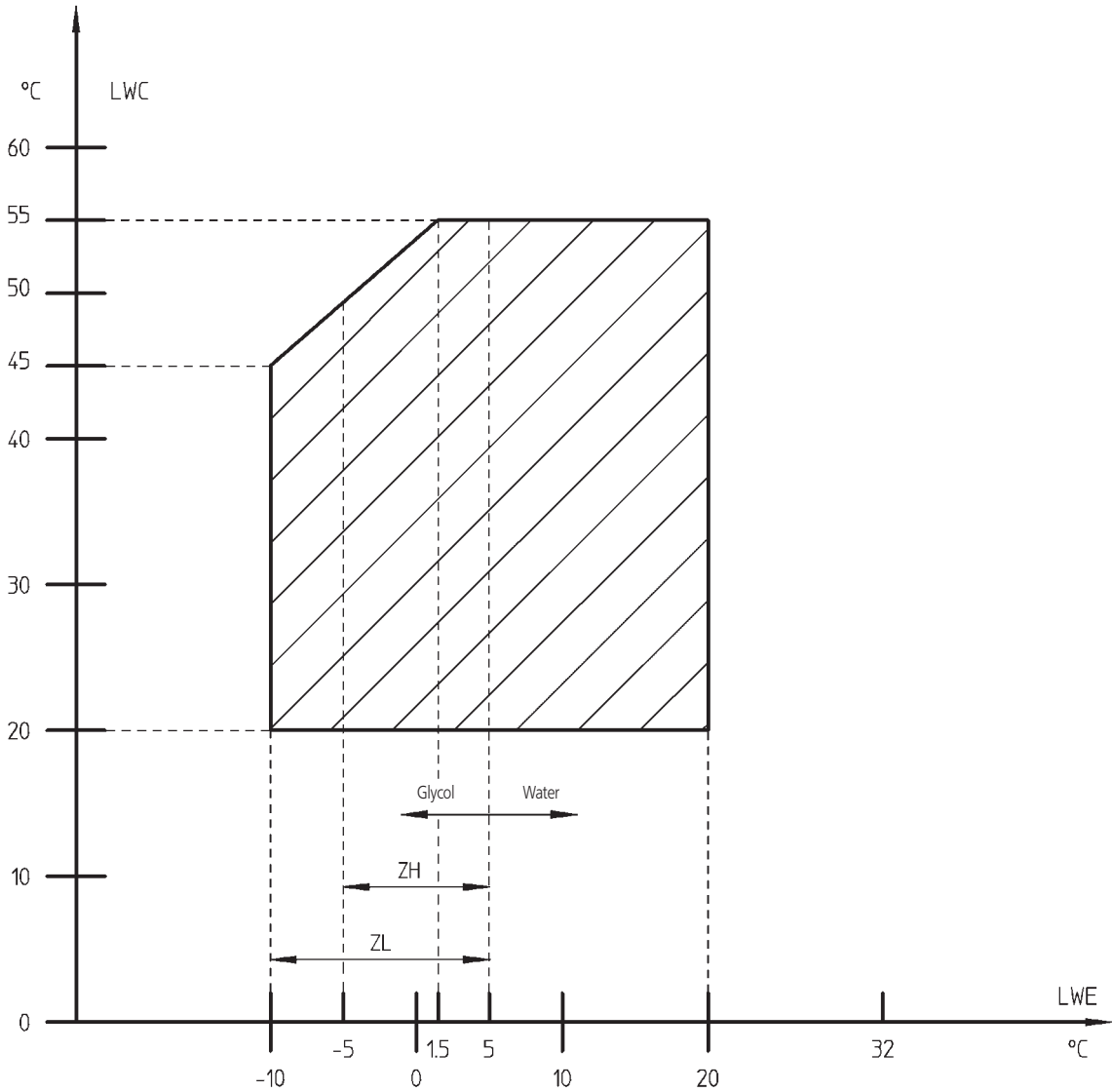

- * LWE = Leaving Water Evaporator (°C)
- * LWC = Leaving Water Condenser (°C)

4TW57193-1

10 Operation range

10 - 1 Operation Range

EWWP045-065KBW1N
90kW (32hp) - 195kW (72hp)

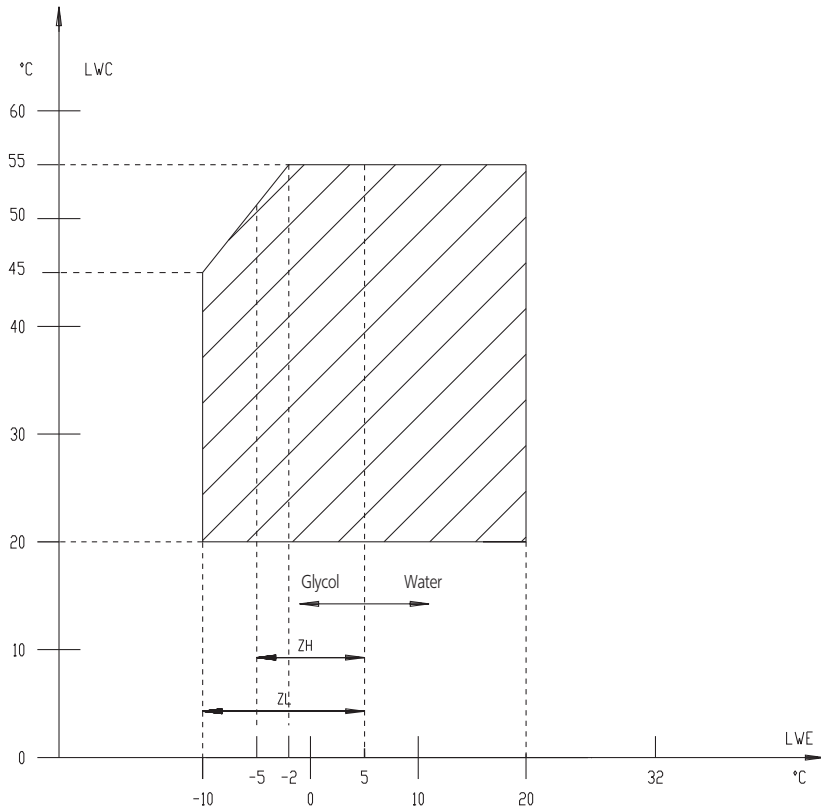

LWE = Leaving Water Evaporator (°C)
 LWC = Leaving Water Condenser (°C)

4TW53473-1B

11 Hydraulic performance

11 - 1 Water Pressure Drop Curve Evaporator/Condenser

EWWP014-035KBW1N

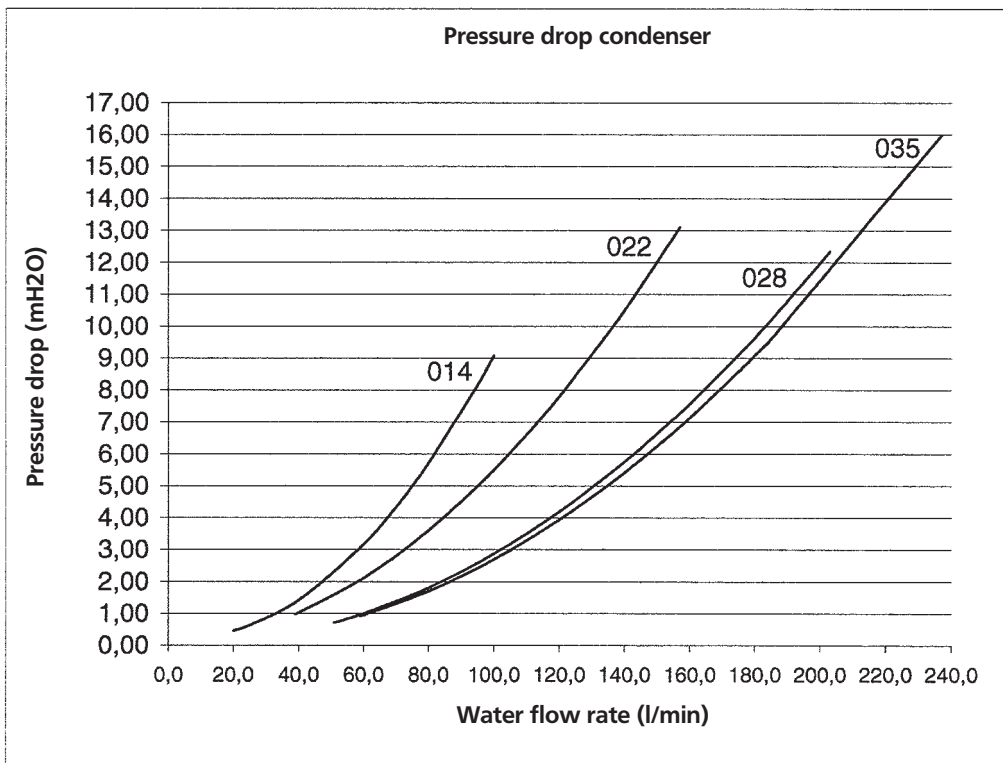
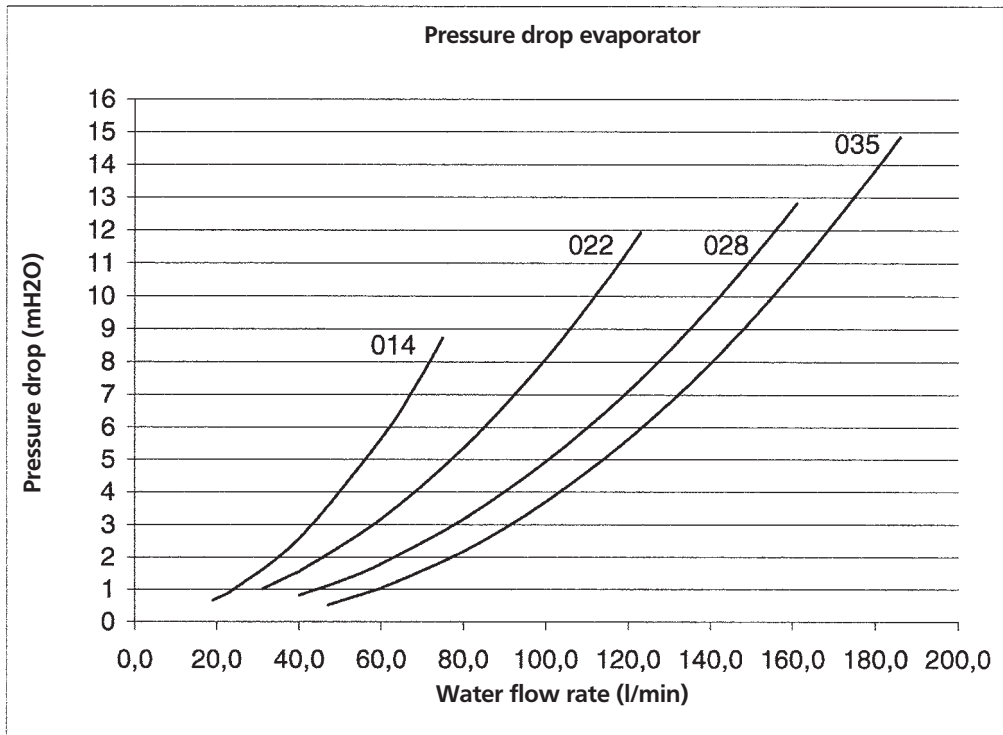

4TW57199-1A

11 Hydraulic performance

11 - 1 Water Pressure Drop Curve Evaporator/Condenser

EWWP045-065KBW1N

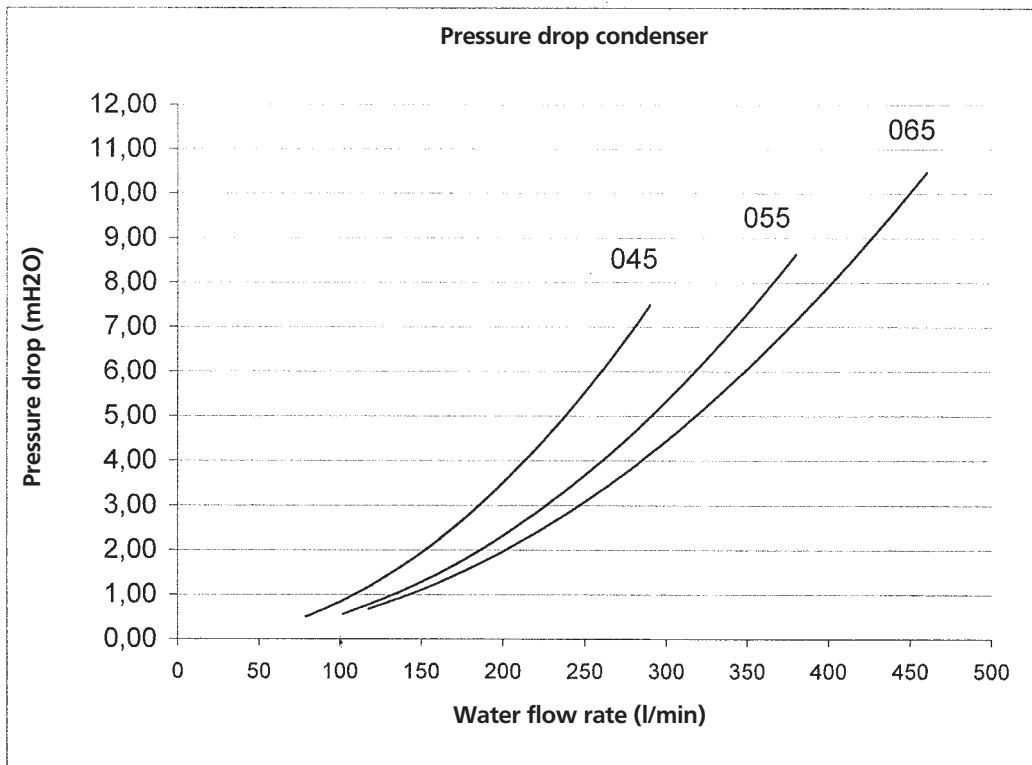
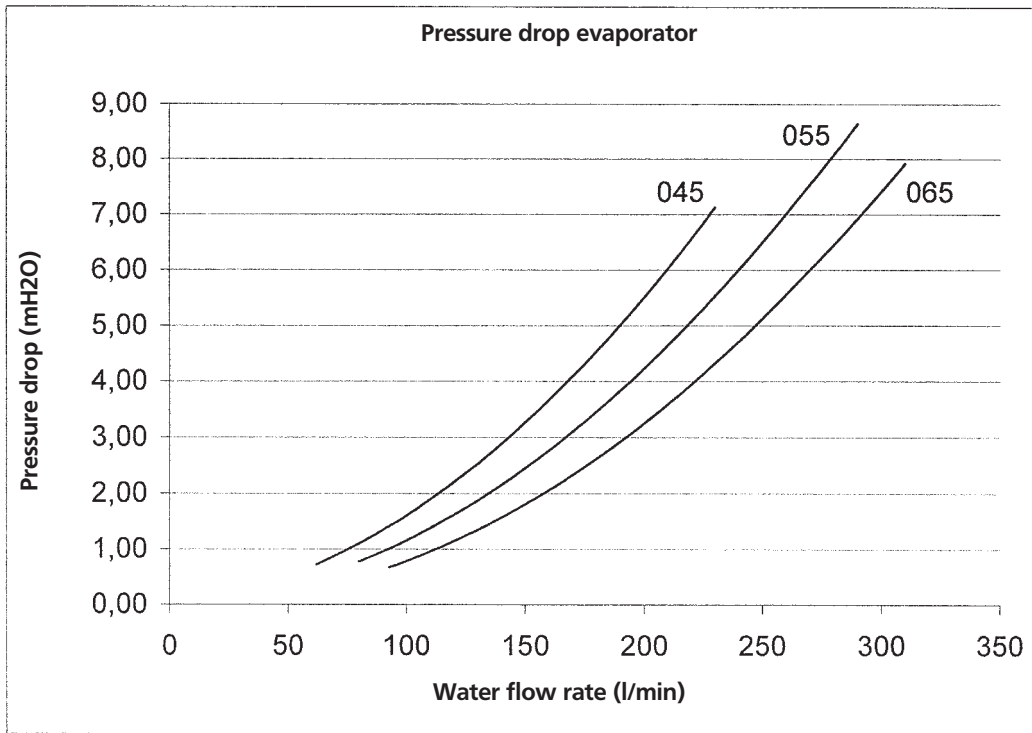

4TW57239-1

11 Hydraulic performance

11 - 1 Water Pressure Drop Curve Evaporator/Condenser

EWWP145-195KBW1N (52-72hp)

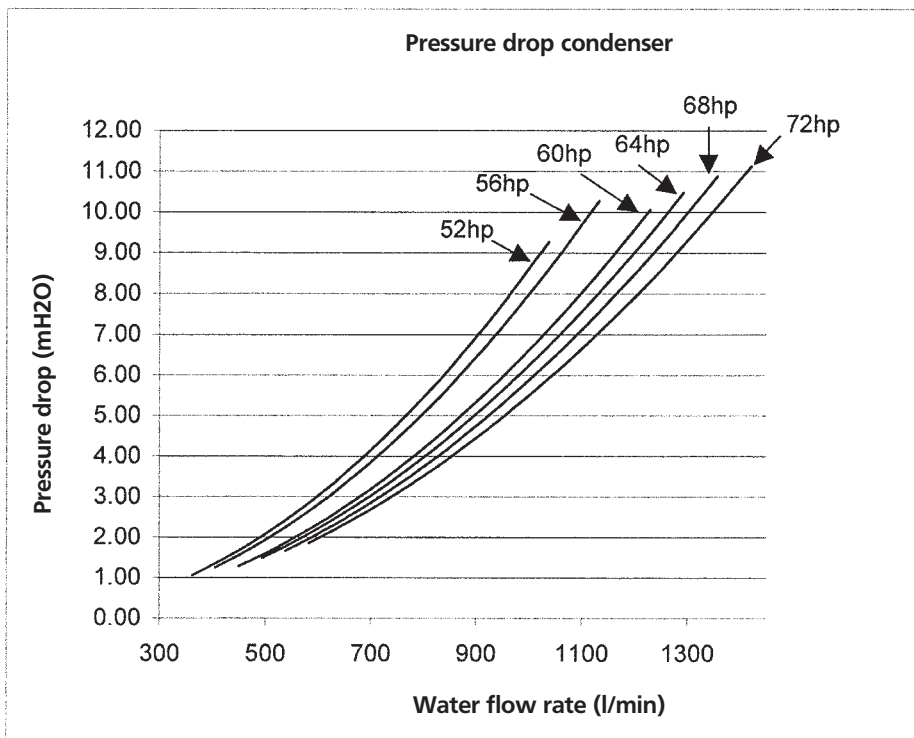
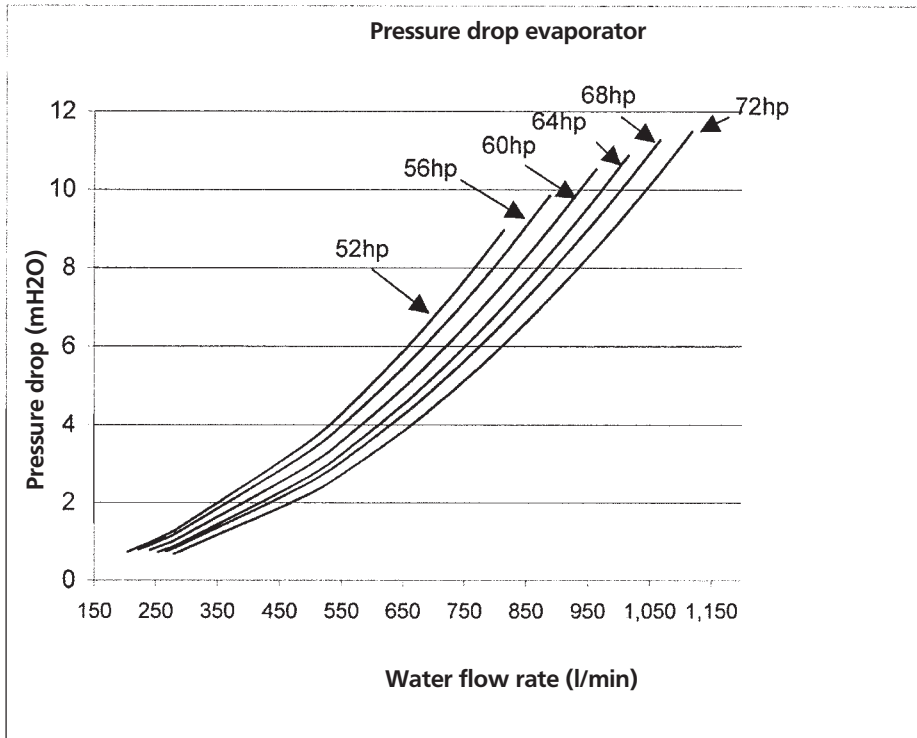

Warning: Selecting a flow outside the curves can cause damage to or malfunction of the unit. See also minimum and maximum allowed water flowrate in the technical specifications.

4TW53479-1A

TABLE OF CONTENTS

EWLP-KBW1N

1	Features	34
2	Specifications	35
	Technical Specifications	35
	Electrical Specifications	35
3	Options	36
	Options	36
4	Capacity tables	37
	Cooling Capacity Tables	37
	Capacity Correction Factor	38
5	Dimensional drawings	39
	Dimensional Drawings	39
6	Centre of gravity	41
	Centre of Gravity	41
7	Piping diagrams	42
	Piping Diagrams	42
8	Wiring diagrams	44
	Wiring Diagrams - Three Phase	44
9	Sound data	46
	Sound Power Spectrum	46
10	Operation range	47
	Operation Range	47
11	Hydraulic performance	49
	Water Pressure Drop Curve Evaporator/Condenser	49

1 Features

- Daikin scroll compressor
- Optimised for use with R-407C
- Electronic DDC controller
- Low operating sound level
- Low energy consumption
- Compact dimensions and low refrigerant volume
- Easy installation and maintenance
- Stainless steel plate heat exchanger
- Compatible with hydraulic module
- Standard integrated: main switch, pressure ports, flow switch, filter, shut-off valves and air purge



2

1

2 Specifications

2-1 Technical Specifications				EWLP012 KBW1N	EWLP020 KBW1N	EWLP026 KBW1N	EWLP030 KBW1N	EWLP040 KBW1N	EWLP055 KBW1N	EWLP065 KBW1N	
Cooling capacity	Nom.	kW		12.1 (1)	20.0 (1)	26.8 (1)	31.2 (1)	40.0 (1)	53.7 (1)	62.4 (1)	
Capacity steps number				1				2			
Power input	Cooling	Nom.	kW	4.2 (2)	6.6 (2)	8.5 (2)	10.1 (2)	13.4 (2)	17.8 (2)	20.3 (2)	
Casing	Colour	Ivory white (Munsell code: 5Y7.5/1)									
	Material	Polyester painted steel plate									
Dimensions	Unit	Height	mm	600							
		Width	mm	600							
		Depth	mm	600				1,200			
Weight	Unit	kg	108	141	147	151	252	265	274		
Water heat exchanger - evaporator	Minimum water volume in the system	l	62	103	134	155	205	268	311		
	Water flow rate	Min.	l/min	17	29	38	45	57	77	89	
		Nom.	l/min	35	57	77	89	115	154	179	
		Max.	l/min	69	115	153	179	229	307	358	
	Insulation material	Polyethylene foam									
	Model	Quantity	1								
Type	Brazen plate										
Sound power level	Cooling	Nom.	dB(A)	64			71	67		74	
Compressor	Type	Hermetically sealed scroll compressor									
	Quantity				1				2		
	Model		JT140BF-YE	JT212DA-YE	JT300DA-YE	JT335DA-YE	JT212DA-YE	JT300DA-YE	JT335DA-YE		
	Speed	rpm	2,900								
	Crankcase heater	W	33								
	Oil	Charged volume	l	1.5	2.7						
Refrigerant	Type	R-407C									
	Control	Thermostatic expansion valve									
	Circuits	Quantity	1				2				
Refrigerant oil	Type	FVC68D									
Piping connections	Evaporator water inlet/outlet	FBSP 25mm						FBSP 40mm			
	Evaporator water drain	Field installation									

2-2 Electrical Specifications				EWLP012 KBW1N	EWLP020 KBW1N	EWLP026 KBW1N	EWLP030 KBW1N	EWLP040 KBW1N	EWLP055 KBW1N	EWLP065 KBW1N	
Compressor	Phase	3~									
	Frequency	Hz	50								
	Voltage	V	400								
	Starting current	A	49	79	109	129	79	109	129		
	Nominal running current (RLA)	A	7.4	11.5	14.3	16.6	11.5	14.3	16.6		
	Maximum running current	A	9	14.5	18.5	22	14	18	20		
	Starting method	Direct on line									
Power supply	Name	W1									
	Phase	3N~									
	Frequency	Hz	50								
	Voltage	V	400								
	Voltage range	Min.	%	-10							
		Max.	%	10							
Unit	Starting current	A	49	79	109	129	93	127	149		
	Current	Zmax	Text	0.27 + j0.17	0.22 + j0.13	0.19 + j0.12		0.20 + j0.12	0.18 + j0.12	0.18 + j0.11	
	Nominal running current (RLA)	Cooling	A	7.4	11.5	14.3	16.6	23.0	28.7	33.3	
		Maximum running current	A	9	14.5	18.5	22	28	36	40	
	Recommended fuses according to IEC standard 269-2			3 x 16A	3 x 20A	3 x 25A		3 x 35A	3 x 40A	3 x 50A	

Notes

(1)Cooling; entering evaporator water temp. 12°C; leaving evaporator water temp. 7°C; condensing temp. 45°C; liquid temp. 40°C; standard: Eurovent. This power input includes beside the power to the unit an addition for the required pump power input.

(2)Cooling; entering evaporator water temp. 12°C; leaving evaporator water temp. 7°C; condensing temp. bubble 45°C; liquid temp. 40°C; standard: Eurovent 6/C/003; condensing temp. bubble corresponds to compressor discharge pressure.

3 Options

3 - 1 Options

EWWP-KBW1
EWLP-KBW1

Optional equipment for EWW/LP-KBW1

Modelnumber

EWWP014KBW1N*	EWWP045KBW1N*	EWLP012KBW1N*	EWLP040KBW1N*
EWWP022KBW1N*	EWWP055KBW1N*	EWLP020KBW1N*	EWLP055KBW1N*
EWWP028KBW1N*	EWWP065KBW1N*	EWLP026KBW1N*	EWLP065KBW1N*
EWWP035KBW1N*		EWLP030KBW1N*	

Option number	Option description	Unit size							Availability
		014WC - 012RC	022WC - 020RC	028WC - 026RC	035WC - 030RC	045WC - 040RC	055WC - 055RC	065WC - 065RC	
	Standard unit	•	•	•	•	•	•	•	
	Not completely combinable options								
ZH	Glycol operation chilled water temp down to -5°C	•	•	•	•	•	•	•	Factory mounted
ZL	Glycol operation chilled water temp down to -10°C	•	•	•	•	•	•	•	Factory mounted
EKAC10C	Available kits Address card for connection to BMS or Remote user interface	•	•	•	•	•	•	•	Kit
EKRUMCA	Remote installed user interface	•	•	•	•	•	•	•	Kit
EKLS1	Low noise operation EUW*5KZW1	•1	—	—	—	—	—	—	Kit
EKLS2	Low noise operation EUW*8-24KZW1	—	•1	•1	•1	•2	•2	•2	Kit
EHMC10AV1010/1080	Hydraulic module	•	•	•	•	•	•	•	Kit
EHMC15AV1010/1080	Hydraulic module	•	•	•	•	•	•	•	Kit
EHMC30AV1010/1080	Hydraulic module	•	•	•	•	•	•	•	Kit

NOTES

- std = standard on unit
 - = available
 - x = available and a quantity of x is needed for this unit size
 - = not available
- Hatched area = preliminary data
- * = option number
- To install EKRUMCA => EKAC10C needs to be installed on the unit.
- EKAC10C : this address card allows direct connection to MODBUS BMS system

4TW60149-5

2

3

4 Capacity tables

4 - 1 Cooling Capacity Tables



Tc [°C]	25		30		35		40		45		50		55		60		
LWE [°C]	CC	PI	CC	PI	CC	PI	CC	PI	CC	PI	CC	PI	CC	PI	CC	PI	
-10	012	7.9	2.8	7.4	3.0	6.8	3.3	6.2	3.6	5.5	4.0	4.7	4.3				
	020	12.4	3.7	12.0	4.2	11.3	4.7	10.4	5.3	9.4	5.9	8.2	6.5				
	026	16.4	5.2	16.4	5.9	15.9	6.6	15.1	7.5	13.9	8.5	12.5	9.5				
	030	20.9	6.2	20.7	6.8	20.5	7.5	19.4	8.5	17.8	9.6	15.7	10.8				
	040	24.7	7.7	24.0	8.7	22.5	9.8	20.7	11.0	18.7	12.2	16.4	13.5				
	055	32.9	10.9	32.8	12.3	31.9	13.8	30.2	15.5	27.8	17.4	25.0	19.4				
	065	41.8	12.4	41.5	13.6	40.9	15.2	38.8	17.0	35.6	19.2	31.5	21.7				
-5	012	9.8	2.8	9.2	3.0	8.7	3.3	8.0	3.7	7.4	4.0	6.7	4.4	5.9	4.8		
	020	15.8	3.9	15.2	4.4	14.5	4.9	13.6	5.5	12.5	6.2	11.3	6.9	9.9	7.6		
	026	20.1	5.4	20.0	6.0	19.6	6.8	18.7	7.6	17.7	8.5	16.3	9.6	14.8	10.7		
	030	24.4	6.3	24.3	6.9	24.0	7.7	23.1	8.6	21.6	9.7	19.7	10.9	17.3	12.2		
	040	31.5	8.2	30.3	9.2	28.8	10.3	27.0	11.5	24.9	12.8	22.5	14.2	19.8	15.6		
	055	40.2	11.3	40.2	12.5	39.3	14.0	37.5	15.7	35.6	17.6	32.7	19.7	29.7	21.9		
	065	48.7	12.7	48.6	13.9	48.1	15.5	46.2	17.3	43.3	19.5	39.3	22.0	34.6	24.4		
0	012	11.8	2.8	11.3	3.1	10.7	3.4	10.1	3.7	9.4	4.1	8.6	4.5	7.8	4.9	6.9	5.5
	020	18.7	4.1	18.1	4.6	17.4	5.1	16.5	5.8	15.4	6.4	14.2	7.2	12.8	8.0	11.5	8.8
	026	23.7	5.5	23.7	6.1	23.3	6.8	22.4	7.6	21.5	8.5	20.1	9.5	18.4	10.6	16.2	11.8
	030	28.0	6.3	27.8	6.9	27.6	7.7	26.7	8.7	25.4	9.8	23.6	11.0	21.3	12.2	18.6	13.7
	040	37.2	8.7	36.1	9.6	34.6	10.7	32.9	11.9	30.7	13.3	28.2	14.8	25.6	16.4	23.0	18.0
	055	47.5	11.5	47.4	12.6	46.6	14.0	45.0	15.6	43.1	17.4	40.4	19.5	36.9	21.7	32.6	24.1
	065	55.9	12.6	55.5	14.0	55.1	15.6	53.4	17.4	50.8	19.6	47.1	22.1	42.5	24.5	37.3	27.4
4	012	13.0	2.8	12.7	3.1	12.3	3.4	11.8	3.7	11.2	4.1	10.4	4.5	9.6	5.0	8.7	5.5
	020	20.7	4.2	20.4	4.7	19.9	5.3	19.5	5.9	18.4	6.6	17.2	7.3	15.9	8.1	14.1	8.9
	026	26.7	5.6	26.6	6.1	26.3	6.8	25.5	7.7	24.5	8.6	23.2	9.6	21.4	10.7	19.4	12.0
	030	30.8	6.5	30.7	7.2	30.5	8.0	29.8	8.9	28.6	9.9	27.0	11.1	25.0	12.4	22.7	13.7
	040	43.3	8.5	42.1	9.6	40.6	10.7	38.8	11.9	36.7	13.3	34.2	14.8	31.6	16.4	29.0	18.0
	055	53.5	11.6	53.4	12.8	52.6	14.2	51.1	15.8	49.1	17.6	46.4	19.6	43.0	21.9	39.0	24.5
	065	61.6	13.1	61.4	14.4	60.9	16.1	59.6	17.9	57.2	20.0	54.0	22.3	50.0	24.9	45.4	27.5
7	012	14.2	2.8	13.8	3.1	13.1	3.4	12.8	3.7	12.1	4.2	11.3	4.6	10.5	5.0	9.7	5.6
	020	22.6	4.3	22.3	4.8	21.9	5.4	21.2	6.0	20.0	6.6	18.6	7.3	16.8	8.1	14.7	9.1
	026	28.9	5.6	28.9	6.2	28.5	6.9	27.8	7.7	26.8	8.5	25.5	9.6	23.7	10.8	21.7	12.0
	030	33.1	6.6	33.0	7.3	32.9	8.1	32.3	9.0	31.2	10.1	29.6	11.2	27.4	12.5	24.8	13.7
	040	46.3	8.9	45.6	9.8	44.2	10.9	42.3	12.1	40.0	13.4	37.1	14.8	33.5	16.5	29.4	18.4
	055	57.9	11.7	57.8	12.9	57.1	14.3	55.6	15.9	53.7	17.8	51.0	19.8	47.6	22.0	43.6	24.3
	065	66.2	13.2	66.1	14.6	65.8	16.2	64.6	18.0	62.4	20.3	59.1	22.5	54.8	25.1	49.6	27.6
10	012	15.4	2.8	15.0	3.1	14.6	3.4	14.1	3.8	13.5	4.2	12.7	4.6	11.8	5.1	10.8	5.5
	020	24.5	4.3	24.3	4.8	23.8	5.4	23.0	6.0	21.9	6.7	20.4	7.4	18.7	8.2	16.7	9.1
	026	30.4	5.6	30.3	6.2	30.0	6.9	29.5	7.7	28.7	8.6	27.5	9.7	25.9	10.8	24.1	12.0
	030	34.5	6.7	34.4	7.4	34.2	8.2	33.6	9.1	32.5	10.1	30.9	11.3	29.0	12.5	26.8	13.8
	040	49.0	8.8	48.5	9.8	47.5	10.9	45.9	12.1	43.7	13.5	40.8	15.0	37.3	16.6	33.4	18.3
	055	60.9	11.7	60.7	12.9	60.2	14.3	59.1	15.9	57.4	17.7	55.1	19.8	51.9	22.0	48.2	24.5
	065	69.0	13.4	68.8	14.8	68.4	16.4	67.1	18.3	64.9	20.4	61.9	22.6	58.0	25.1	53.5	27.7
14	012	16.2	2.8	16.2	3.2	16.2	3.5	15.9	3.8	15.4	4.3	14.6	4.7	13.5	5.2	12.3	5.5
	020	26.4	4.3	26.3	4.8	26.0	5.4	25.4	6.0	24.4	6.7	23.0	7.5	21.2	8.3	19.4	9.0
	026	32.3	5.6	32.2	6.2	32.1	6.9	31.8	7.7	31.2	8.6	30.2	9.6	28.8	10.8	27.2	12.0
	030	38.4	6.7	38.3	7.4	37.9	8.2	37.3	9.2	36.2	10.2	34.8	11.3	33.2	12.5	30.4	13.8
	040	52.6	8.8	52.5	9.8	52.0	10.9	50.7	12.1	48.6	13.6	45.8	15.2	42.4	16.7	38.7	18.2
	055	64.6	11.7	64.5	12.9	64.3	14.3	63.7	16.0	62.4	17.7	60.5	19.8	57.7	22.0	54.4	24.5
	065	76.7	13.5	76.6	14.9	75.9	16.6	74.5	18.4	72.4	20.4	69.7	22.6	66.4	25.1	62.8	27.7
16	012	16.7	2.8	16.7	3.1	16.6	3.5	16.4	3.8	16.0	4.3	15.3	4.7	14.3	5.2	13.2	5.5
	020	27.2	4.3	27.1	4.8	26.9	5.4	26.4	6.0	25.4	6.7	24.2	7.5	22.5	8.3	20.7	9.0
	026	32.6	5.6	32.5	6.2	32.5	7.0	32.2	7.8	31.7	8.7	30.9	9.7	29.7	10.8	28.3	12.0
	030	38.8	6.7	38.7	7.5	38.4	8.3	37.9	9.2	37.0	10.2	35.8	11.3	34.1	12.5	32.3	13.9
	040	54.3	8.8	54.1	9.8	53.7	10.9	52.7	12.1	50.8	13.6	48.2	15.1	44.9	16.7	41.2	18.2
	055	65.3	11.7	65.2	12.9	65.0	14.4	64.5	16.0	63.5	17.8	61.8	19.8	59.5	22.1	56.7	24.5
	065	77.6	13.6	77.4	15.0	76.9	16.7	75.9	18.6	74.0	20.5	71.5	22.7	68.3	25.2	64.7	27.8
20	012	17.6	2.8	17.6	3.1	17.5	3.5	17.5	3.8	17.2	4.3	16.7	4.7	15.9	5.1	14.9	5.5
	020	28.8	4.3	28.8	4.8	28.7	5.3	28.3	5.9	27.6	6.7	26.5	7.4	25.0	8.2	23.2	9.0
	026	33.2	5.6	33.2	6.3	33.1	7.0	33.1	7.8	32.8	8.8	32.2	9.8	31.5	10.9	30.6	12.0
	030	40.9	6.7	40.8	7.5	40.8	8.3	40.6	9.3	40.5	10.2	40.2	11.3	38.7	12.5	36.8	13.9
	040	57.6	8.7	57.5	9.7	57.2	10.8	56.5	12.1	55.2	13.5	53.0	15.0	50.0	16.6	46.3	18.2
	055	66.6	11.7	66.5	13.0	66.4	14.5	66.3	16.1	65.6	18.0	64.5	20.0	63.0	22.2	61.3	24.4
	065	84.5	13.5	84.4	15.0	84.2	16.7	83.8	18.6	82.6	20.5	80.4	22.7	77.3	25.2	73.7	28.0

4TW57292-1A

NOTES

- 1 **CC**
According to Eurovent rating standard 6/C/003-2003 and valid for chilled water range Dt=3-8°C
- 2 **PI**
According to Eurovent rating standard 6/C/003-2003 (compressor + control circuit).

SYMBOLS

- CC** : Cooling capacity (kW)
- PI** : Power input (kW)
- TC** : Condensing temperature bubble (°C)
- LWE** : Leaving water evaporator (°C)

4 Capacity tables

4 - 2 Capacity Correction Factor

Required glycol concentration

Type	Concentration (wt%)	0	10	20	30	40
Ethylene glycol	Freezing point °C	0	-4	-9	-16	-23
	Minimum LWE °C	4	2	0	-5	-11
Propylene glycol	Freezing point °C	0	-3	-7	-13	-22
	Minimum LWE °C	4	3	-2	-4	-10

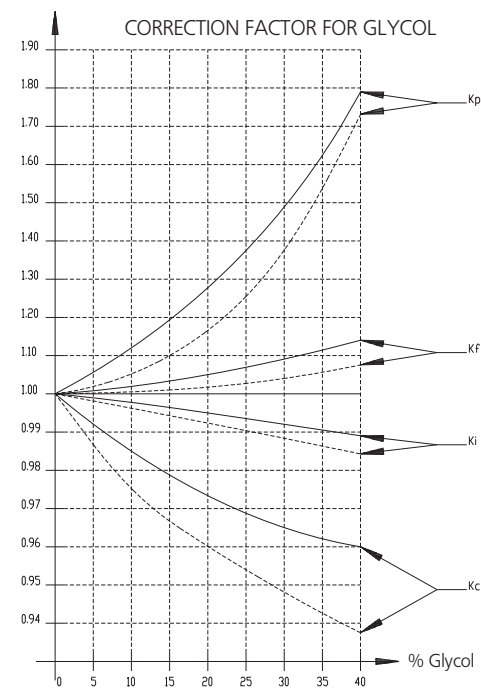

Legend

- Ethylene glycol
- - - Propylene glycol
- Kc Correction on cooling capacity
- Ki Correction on power input
- Kf Correction on flow rate
- Kp Correction on pressure drop

4TW54179-1

5 Dimensional drawings

5 - 1 Dimensional Drawings

EWLP012-030KBW1N

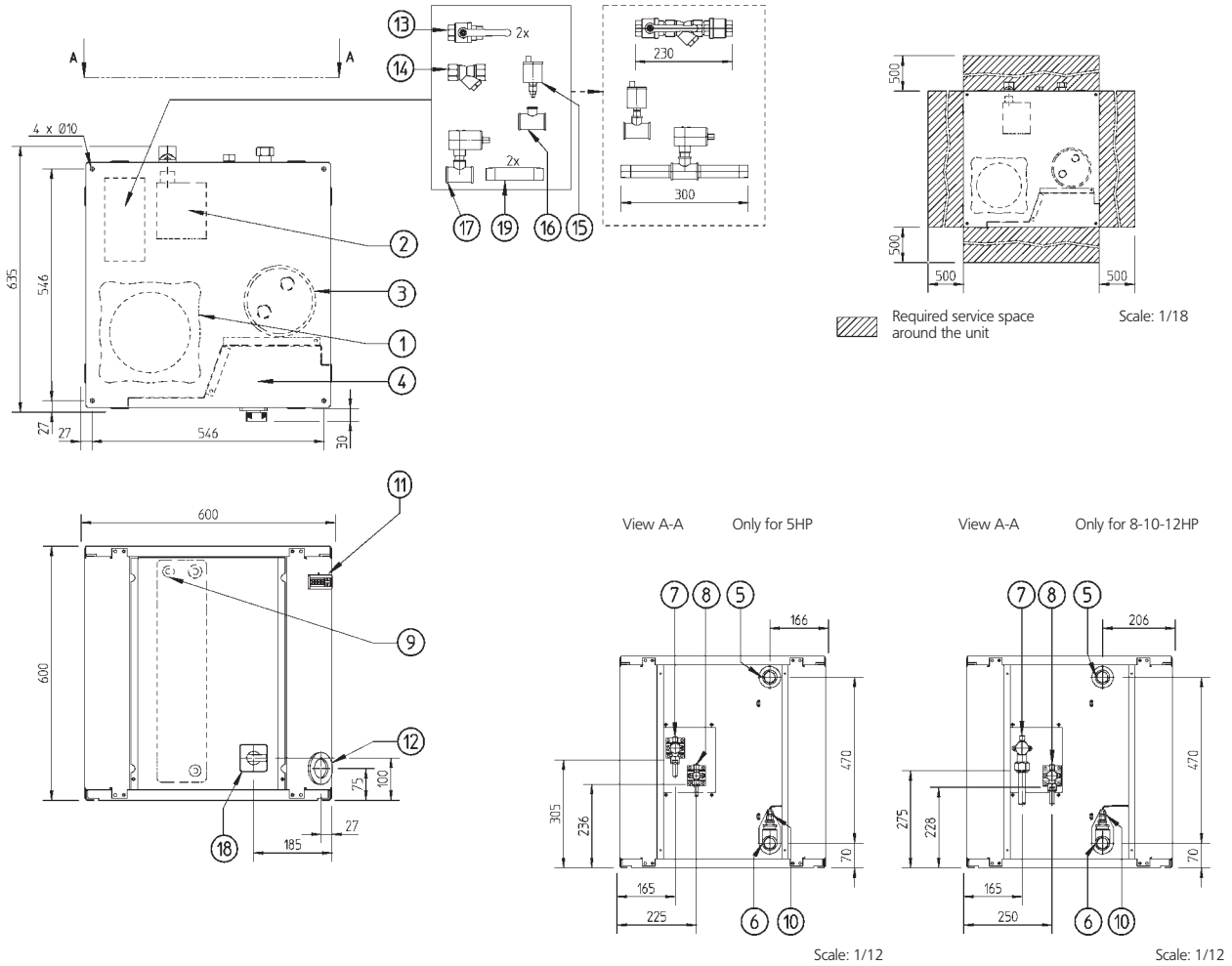

- | | |
|---|--|
| <ul style="list-style-type: none"> 1 Compressor 2 Evaporator 3 Accumulator 4 Switchbox 5 Chilled water in 6 Chilled water out 7 Discharge stop valve 8 Liquid stop valve 9 Evaporator entering water temperature sensor 10 Freeze up sensor | <ul style="list-style-type: none"> 11 Digital display controller 12 Power supply intake (ϕ 48) 13 Ballvalve 14 Water filter 15 Air purge 16 T-joint for air purge 17 Flow switch 18 Main switch 19 Flow switch pipe |
|---|--|

3TW55254-2B

5 Dimensional drawings

5 - 1 Dimensional Drawings

EWLP040-065KBW1N

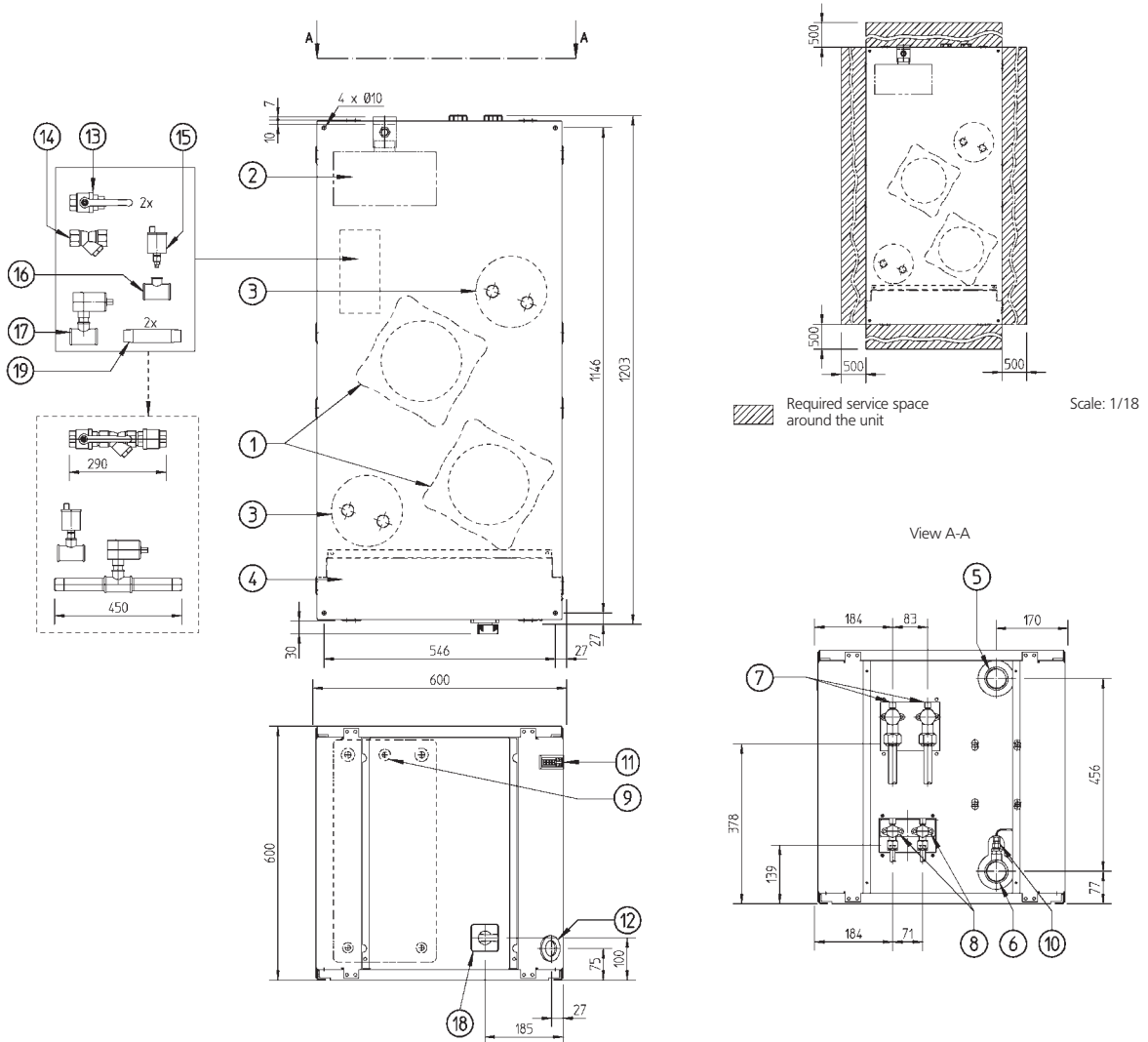

- | | |
|--|-------------------------------|
| 1 Compressor | 11 Digital display controller |
| 2 Evaporator | 12 Power supply intake (φ 48) |
| 3 Accumulator | 13 Ballvalve |
| 4 Switchbox | 14 Water filter |
| 5 Chilled water in | 15 Air purge |
| 6 Chilled water out | 16 T-joint for air purge |
| 7 Discharge stop valve | 17 Flow switch |
| 8 Liquid stop valve | 18 Main switch |
| 9 Evaporator entering water temperature sensor | 19 Flow switch pipe |
| 10 Freeze up sensor | |

3TW55304-2B

2
5

6 Centre of gravity

6 - 1 Centre of Gravity

EWLP012-030KBW1N

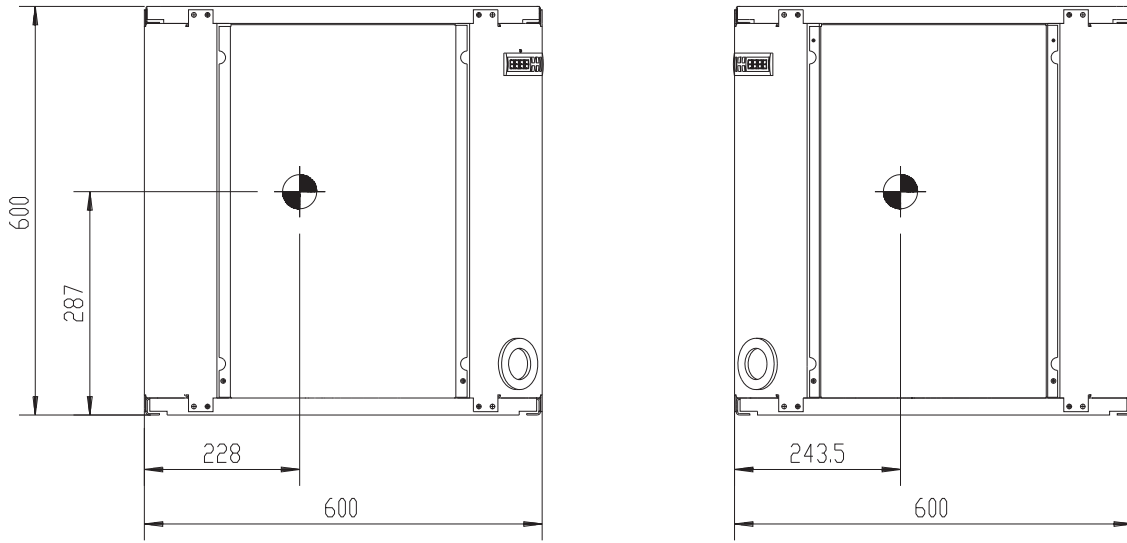

4TW54629-2

EWLP040-065KBW1N

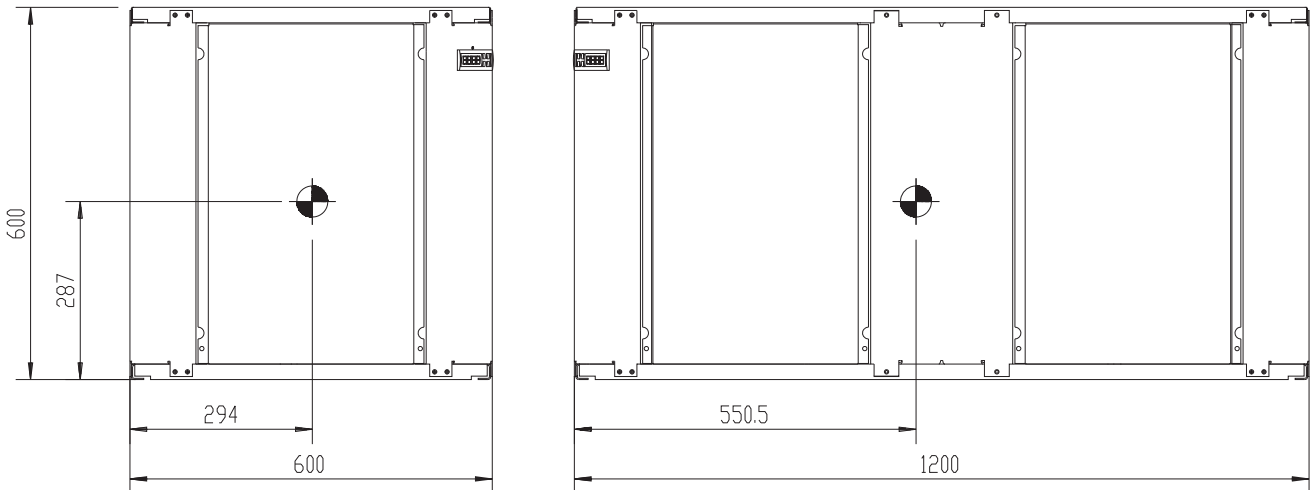

4TW54629-3

7 Piping diagrams

7 - 1 Piping Diagrams

EWLP012-030KBW1N

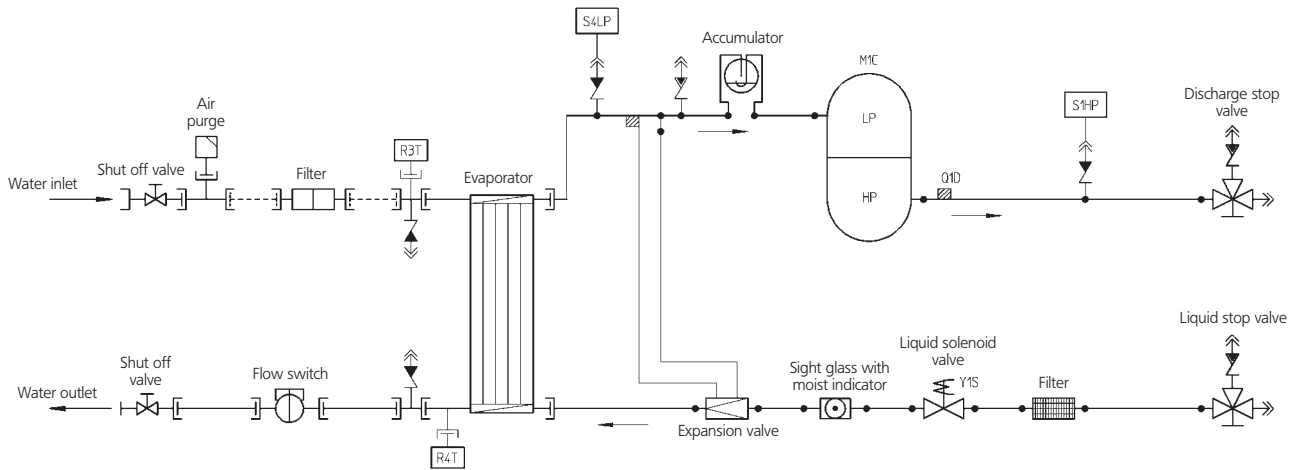

- Y1S Liquid solenoid valve
- M1C Compressor motor 1
- R4T Freeze-up protection
- S1HP High pressure switch
- S4LP Low pressure switch
- R3T Inlet water evap. temp. sensor
- Q1D Discharge temperature controller

- Field piping
- ↔ Check valve
- ↔ Flare connection
- ↔ Screw connection
- ↔ Flange connection
- ✕ Pinched pipe
- Spinned pipe

3TW55255-2B

2
7

7 Piping diagrams

7 - 1 Piping Diagrams

EWLP040-065KBW1N

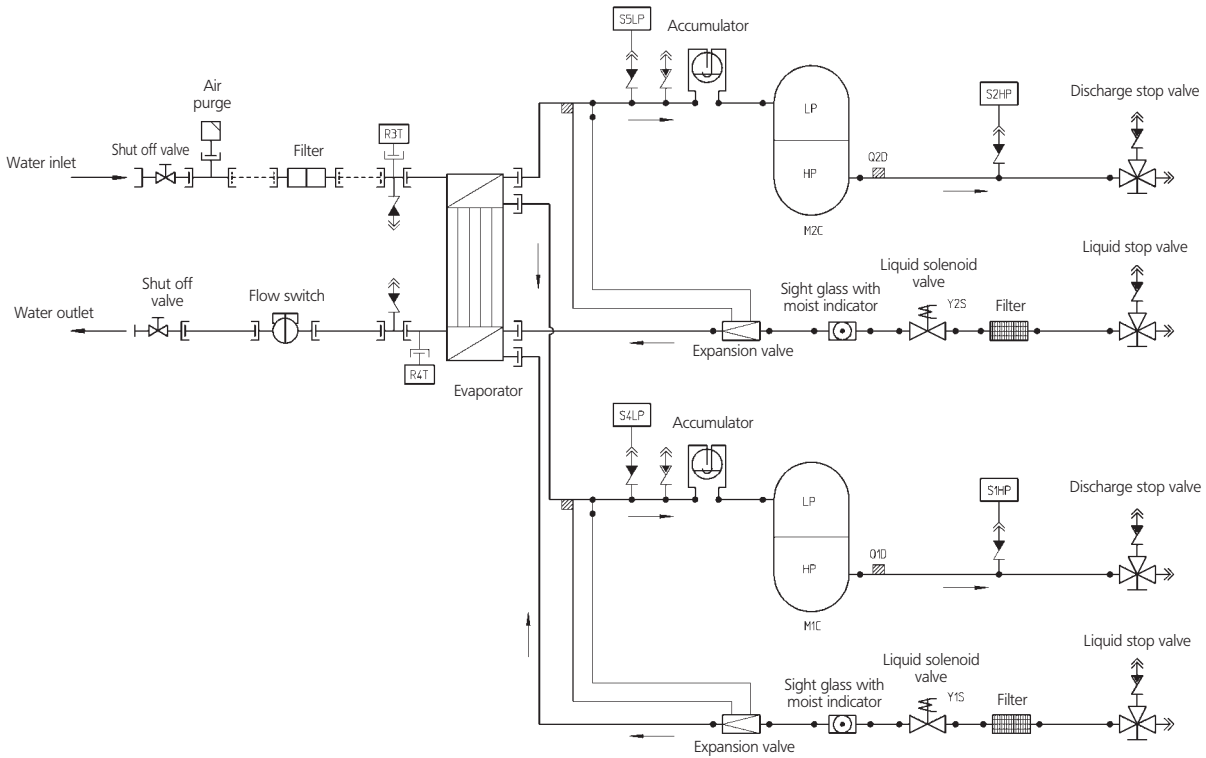

- Y1S Liquid solenoid valve
- Y2S Liquid solenoid valve
- M1C Compressor motor
- M2C Compressor motor
- R4T Freeze-up protection
- R5T Inlet water cond. temp. sensor
- S1HP High pressure switch
- S2HP High pressure switch
- S4LP Low pressure switch
- S5LP Low pressure switch
- R3T Inlet water evap. temp. sensor
- Q1D Discharge temperature controller
- Q2D Discharge temperature controller

- Field piping
- ↔ Check valve
- ← Flare connection
- Screw connection
- Flange connection
- × Pinched pipe
- Spinned pipe

3TW55305-2B

8 Wiring diagrams

8 - 1 Wiring Diagrams - Three Phase

EWLP-KBW1N

	Not standard included	
	Not possible as option	Possible as option
Obligatory	#	##
Not obligatory	*	**

A2P	A1P
DIGITAL INPUTS	DIGITAL INPUTS
D11 Reverse phase detection (L1-N)	X1 (ID1-GND) : Flow switch
D12 Reverse phase detection (N-L3)	X1 (ID2-GND) : Remote C/H selection
D13 M1C ON detection	X1 (ID3-GND) : High pressure switch + discharge protector + overcurrent
D14 M2C ON detection	X1 (ID4-GND) : Low pressure switch
D15 Safety device detection	X1 (ID5-GND) : Remote On/Off
D16 Pump ON detection	
D17 --	DIGITAL OUTPUTS (RELAYS)
D18 --	X2 (C1/2-NO1) : Compressor M1C on
D19 --	X2 (C1/2-NO2) : Compressor M2C on
D110 Reverse valve request	X2 (C3/4-NO3) : Voltage free contact for pump
DIGITAL OUTPUTS (RELAYS)	X2 (C3/4-NO4) : Reversing valve
RY1 Reversed phase protector	X2 (C5-NO5) : Alarm voltage free contact
RY3 Pump/general operation	
RY9 M1C off (during defrost)	ANALOG INPUTS
RY10 M2C off (during defrost)	X1 (B1-GND) : evap. inlet water t°
OTHERS	X1 (B2-GND) : evap. outlet water t°
HAP Light emitting diode (service monitor green)	X1 (B3-GND) : cond. inlet water t°
H1P,H2P Light emitting diode (service monitor red)	ANALOG OUTPUTS
S1A Dipswitch (unit setting)	X1 (Y-GND)
S2A Dipswitch (defr. & fan setting)	

	All models (400V)					
Fuses + overcurrent	WC014	WC022	WC028	WC035	WC045	WC065
	RC012	RC020	RC026	RC030	RC040	RC065
F1,F2,F3 (=gL/gG)	3x16A	3x20A	3x25A	3x32A	3x40A	3x50A
F4	8A	8A	8A	8A	8A	8A
F5	250mAT	250mAT	250mAT	250mAT	250mAT	250mAT
F1U	5A	5A	5A	5A	5A	5A
F3U	315mAT	315mAT	315mAT	315mAT	315mAT	315mAT
K4S	9A	14.5A	18.5A	22A	14A	18A
K5S	-	-	-	-	14A	18A

Y3R *	Reverse valve of water circuit	R3T	Evaporator inlet water temperature sensor	F3U	Fuse controller PCB
Y1S,Y2S	Liquid solenoid valve circuit 1, circuit 2	Q1D,Q2D	Discharge thermal protector circuit 1, circuit 2	F1U	Fuse I/O PCB
X1-82(A/B/M)	Connectors	PE	Main earth terminal	F6 #	Fuse for pumpcontactor
TR2	Transfo 230V-24V for supply of I/O PCB	M1C,M2C	Compressor motor circuit 1, circuit 2	F5 ##	Surge proof fuse
TR1	Transfo 230V-24V for supply of controller PCB	K1P *	Pump contactor	F4	Fuse I/O PCB
S12M	Main isolator switch	K1F,K2F #	Fan contactor	F1,F2,F3 #	Main fuses for the unit
S10L	Flowswitch	K6S *	Overcurrent relay pump	E1H,E2H	Crankcase heater circuit 1, circuit 2
S9S *	Switch for remote start/stop or dual setpoint	K4S,K5S	Overcurrent relay circuit 1, circuit 2	A72P **	PCB: Power supply card
S7S *	Switch for remote cooling/heating selection or dual setpoint	K1M, K2M	Compressor contactor circuit 1, circuit 2	A71P **	PCB: Remote user interface
S4L,S5LP	Low pressure switch circuit 1, circuit 2	M1C,M2C	Compressor motor circuit 1, circuit 2	A3P **	PCB: Address card
S1HP,S2HP	High pressure switch circuit 1, circuit 2	H6P *	Indication lamp general operation	A2P	PCB: I/O PCB
R5T	Condenser inlet water temperature sensor	H5P *	Indication lamp operation compressor 2	A1P	PCB: controller PCB
R4T	Evaporator outlet water temperature sensor	H4P *	Indication lamp operation compressor 1		
		H3P *	Indication lamp alarm		

NOTES

- Terminal 1, : Wire 2, : Field wiring to be in accordance with the local electrical regulations, : Earth wiring, : Option, : PCB, : outside switchbox
- If compressor rotates reversely, it may be damaged
- WC: Watercooled chiller
RC: Unit with remote condensor
- Optional:
- EKAC10C = Address card kit for Modbus or remote user interface connection
- EKSS = softstart
- EKRUCA = Remote user interface
- Terminals for fieldwiring
X1M: H3-6P,Y3R,K1-2F: output terminal for fieldwiring (voltage free contact max 2A / output)
X3M: S7S,S9S: Input terminal for fieldwiring (don't connect voltage)(switch load 6mA / 30VDC)
- Y3R is activated in cooling mode
S7S open = heating
S7S closed = cooling
- Dipswitch setting
S2A dipswitch: Defrost & Fan setting
no meaning for WC CO & WC CL CO

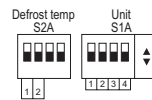

S1A dipswitch: Unit setting

- 1 > Off= 1 circuit
- On= 2 circuit
- 234 > Off Off = WC CO & WC CL CO
- Off On = AC CO
- On Off = AC HP (without compr. stop for defrost cycle)
- On On = AC HP (with compr. stop for defrost cycle)

7. Pump contact

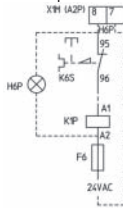

9 Sound data

9 - 1 Sound Power Spectrum

2
9

EWLP012-026KBW1N

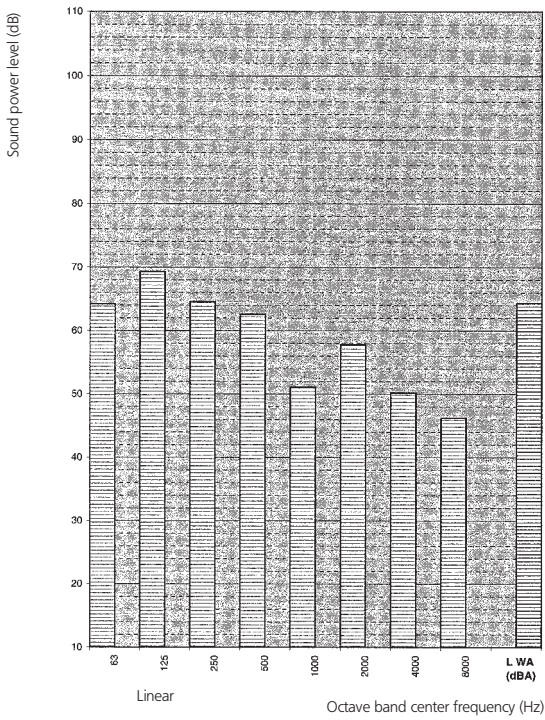

4TW57197-1

NOTES

Option low noise = -3dBa

EWLP030KBW1N

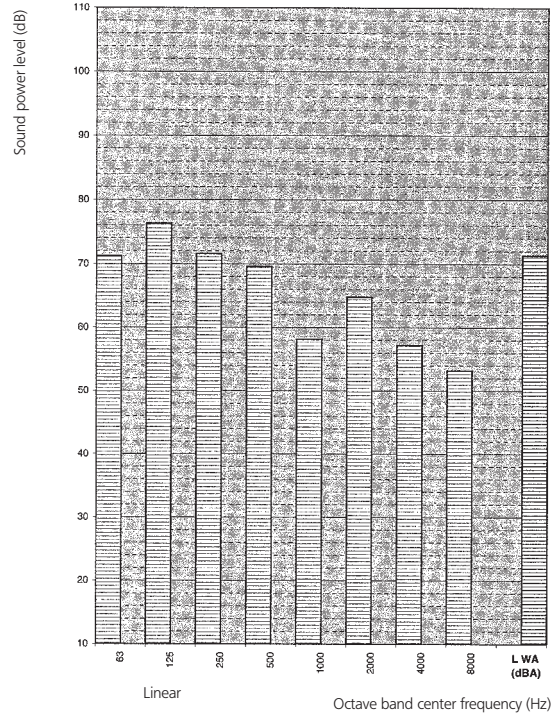

4TW57197-2

NOTES

Option low noise = -3dBa

EWLP040-055KBW1N

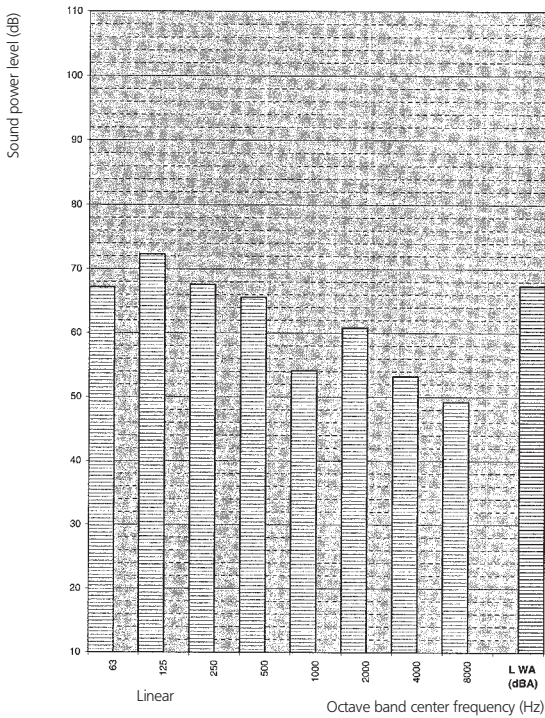

4TW57197-3

NOTES

Option low noise = -3dBa

EWLP065KBW1N

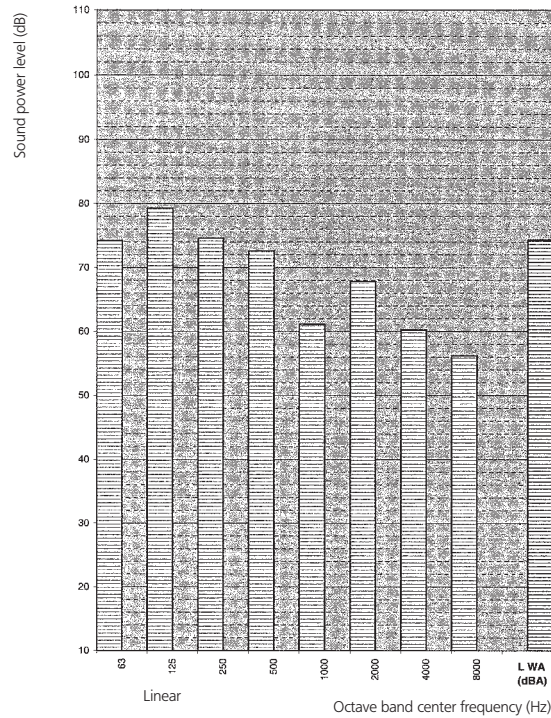

4TW57197-4

NOTES

Option low noise = -3dBa

10 Operation range

10 - 1 Operation Range

EWLP012-030KBW1N

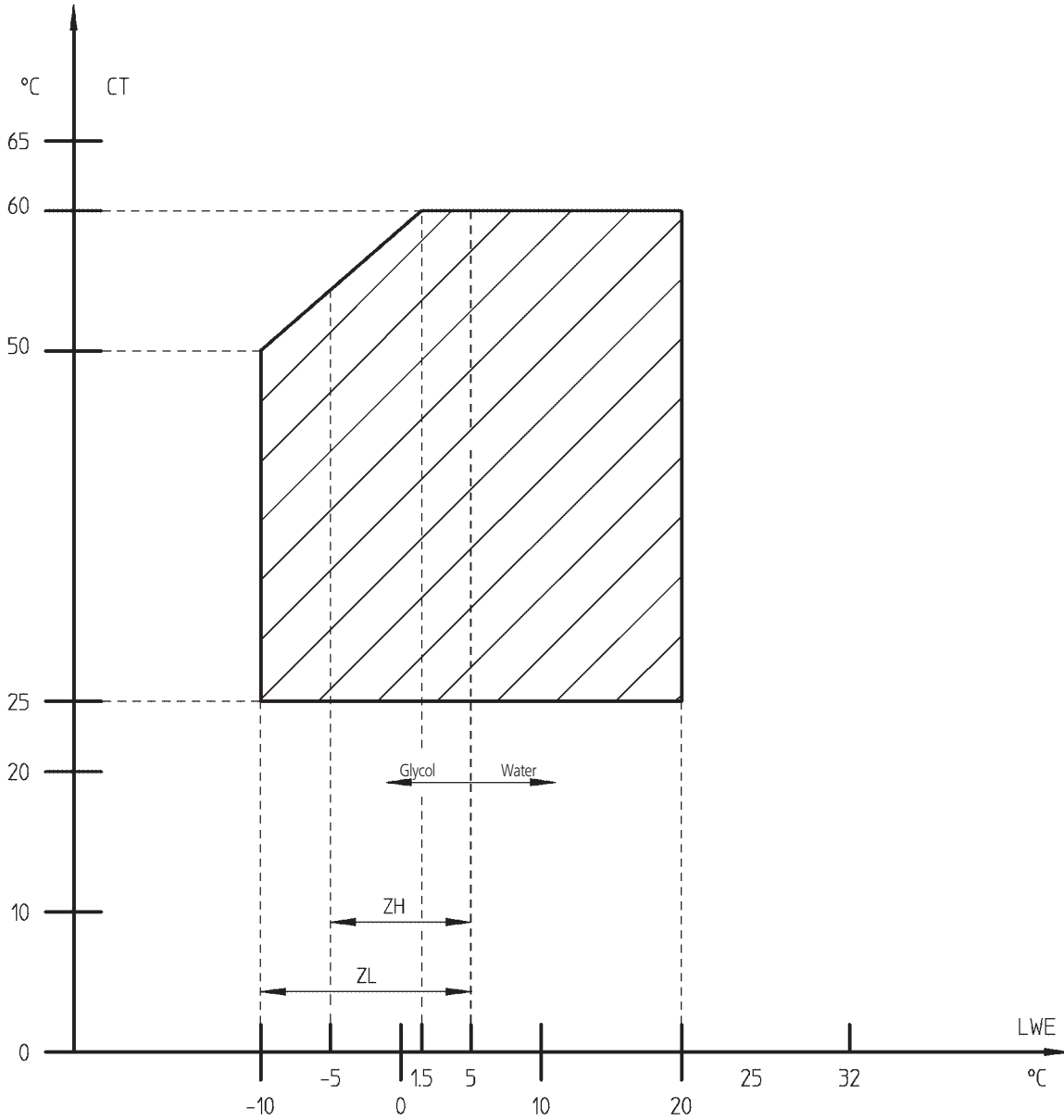

- * LWE = Leaving Water Evaporator (°C)
- * CT = Condensing Temperature (°C)

4TW57293-1

10 Operation range

10 - 1 Operation Range

2
10

EWLP040-065KBW1N

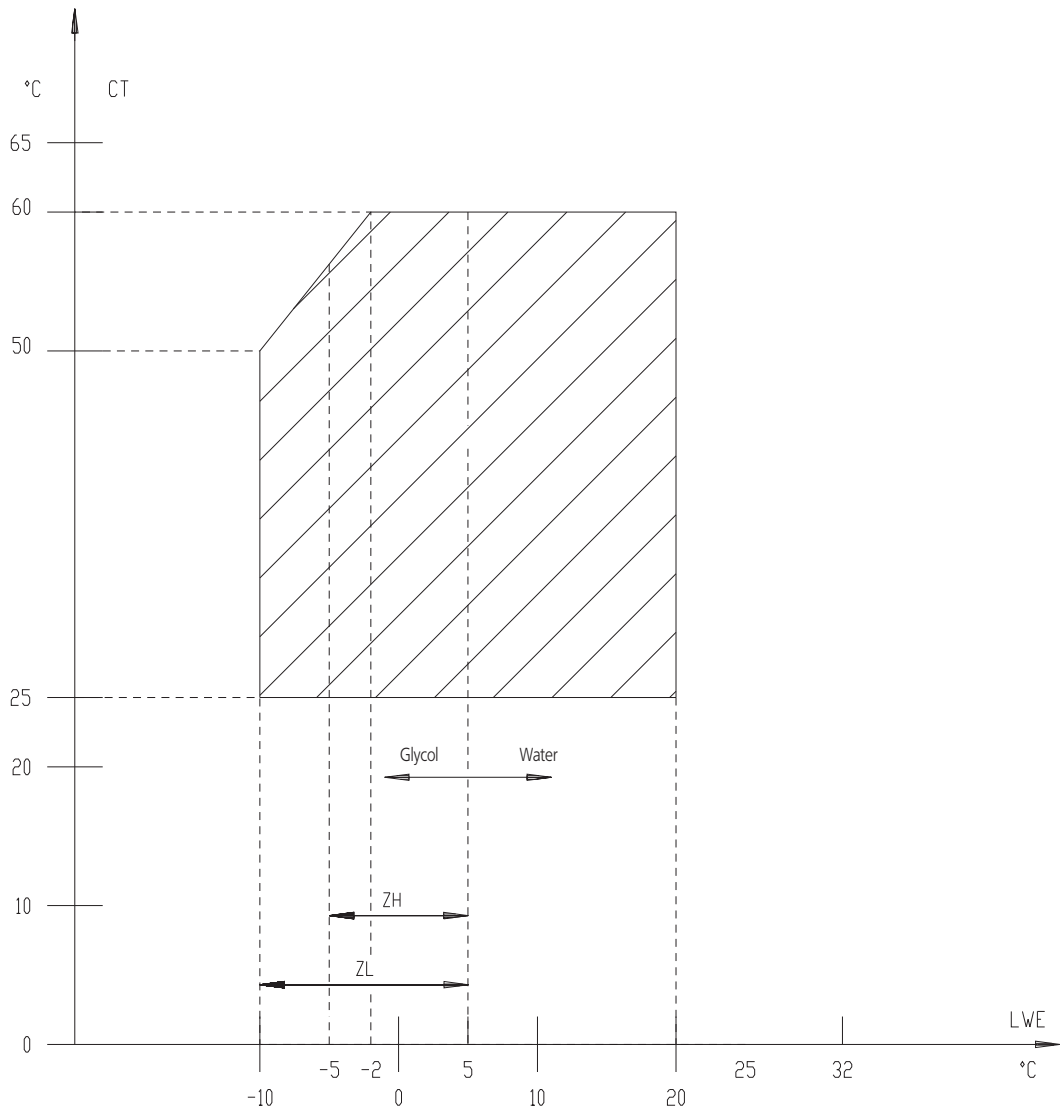

LWE = Leaving Water Evaporator (°C)
CT = Condensing temperature (°C)

4TW53473-2

11 Hydraulic performance

11 - 1 Water Pressure Drop Curve Evaporator/Condenser

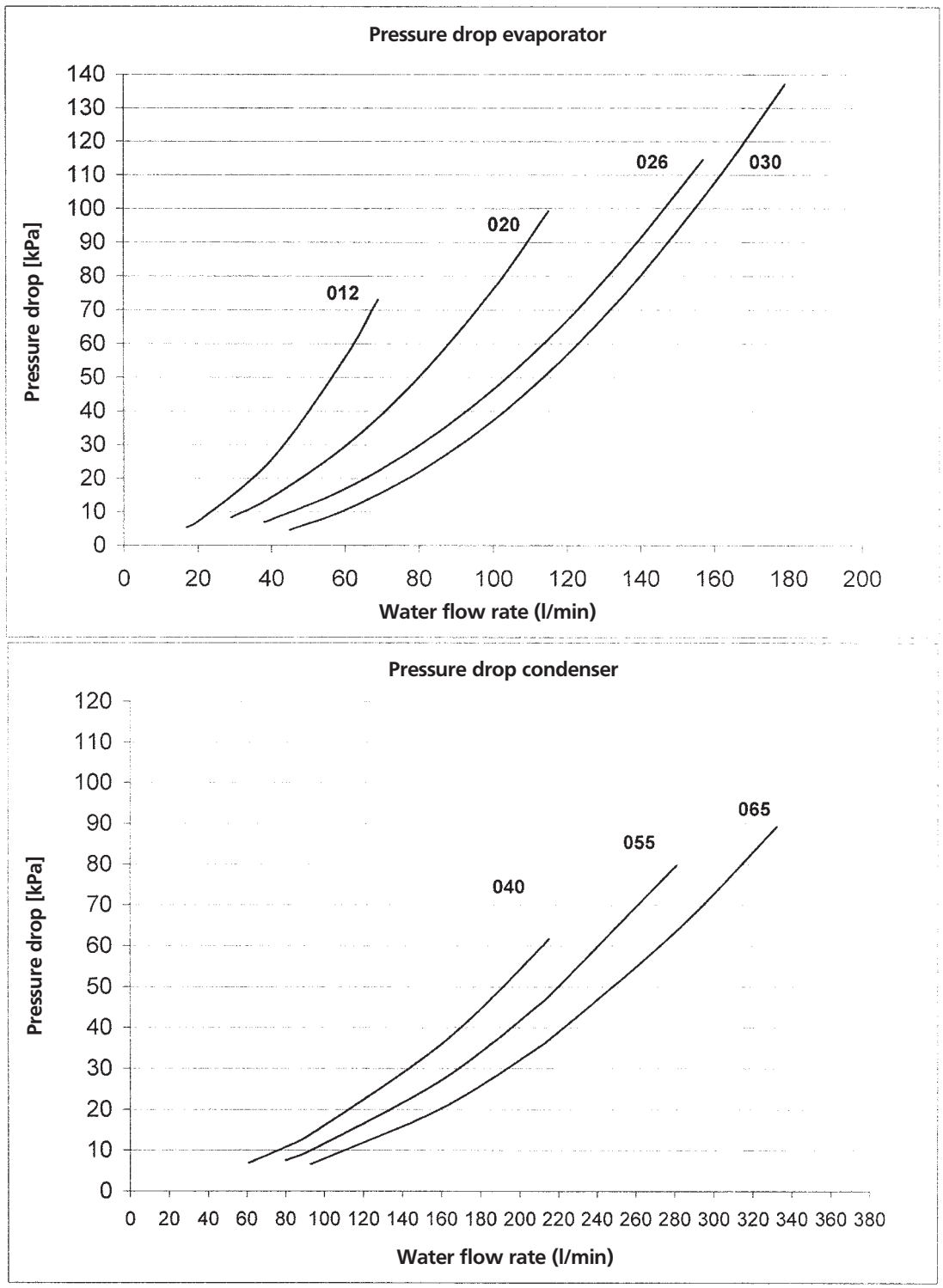

Warning: Selecting a flow outside the curves can cause damage to or malfunction of the unit. See also minimum and maximum allowed water flowrange in the technical specifications.

4TW57299-1A



Daikin's unique position as a manufacturer of air conditioning equipment, compressors and refrigerants has led to its close involvement in environmental issues. For several years Daikin has had the intention to become a leader in the provision of products that have limited impact on the environment. This challenge demands the eco design and development of a wide range of products and an energy management system, resulting in energy conservation and a reduction of waste.



The present publication is drawn up by way of information only and does not constitute an offer binding upon Daikin Europe N.V. Daikin Europe N.V. has compiled the content of this publication to the best of its knowledge. No express or implied warranty is given for the completeness, accuracy, reliability or fitness for particular purpose of its content and the products and services presented therein. Specifications are subject to change without prior notice. Daikin Europe N.V. explicitly rejects any liability for any direct or indirect damage, in the broadest sense, arising from or related to the use and/or interpretation of this publication. All content is copyrighted by Daikin Europe N.V.

Daikin products are distributed by:



Daikin Europe N.V. is participating in the EUROVENT Certification Programme. Products are as listed in the EUROVENT Directory of Certified Products.