



Chillers

# Technical Data

Air cooled chiller, multiple scroll



ECDEN11-405

EWAQ-DAYN  
EWYQ-DAYN

**R-410A**



Chillers

# Technical Data

Air cooled chiller, multiple scroll

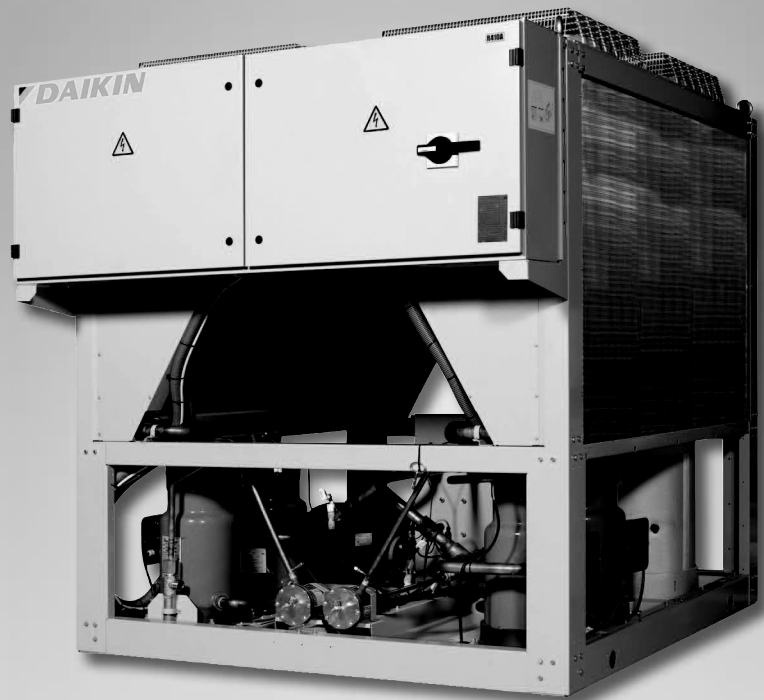

ECDEN11-405

EWAQ-DAYN  
EWYQ-DAYN

**R-410A**

# TABLE OF CONTENTS

## EWAQ-DAYN

1	Features .....	2
2	Specifications .....	3
	Technical Specifications .....	3
	Electrical Specifications .....	4
3	Options .....	5
	Options .....	5
4	Capacity tables .....	11
	Cooling Capacity Tables .....	11
	Capacity Correction Factor .....	13
5	Dimensional drawings .....	14
	Dimensional Drawings .....	14
6	Piping diagrams .....	18
	Piping Diagrams .....	18
7	External connection diagrams .....	22
	External Connection Diagrams .....	22
8	Sound data .....	23
	Sound Power Spectrum .....	23
9	Installation .....	24
	Fixation and Foundation of Units .....	24
	Water Charge, Flow and Quality .....	27
10	Operation range .....	28
	Operation Range .....	28
11	Hydraulic performance .....	30
	Water Pressure Drop Curve Evaporator .....	30
	Static Pressure Drop Unit .....	33

# 1 Features

- Wide capacity range: 80 to 260kW with 8 cooling only models
- Optimised for use with R-410A
- Multiple refrigerant circuits and multiple compressors per circuit
- Reliable and efficient scroll with high EER values
- Anti-corrosion treated aluminium coils
- Low operating sound level
- Easy 'plug and play' installation
- Unit dimensions allow easy transportation
- Fans protected against abnormal operation (4 to 8 fans depending on unit size)
- Safety valves in each circuit
- Electronic circuit breakers
- Electronic expansion valve
- True dual plate brazed plate heat exchanger
- Sight glass
- All hydronics can be accessed easily from 3 sides (no surrounding cabinet)
- Separate switchbox for easy access
- Compressors and controls at unit side
- Increased reliability via 2 independent refrigerant circuits
- Double circuit heat exchanger (from 100kW onwards)
- Non hermetic filter/dryer
- Daikin Pcaso controller with user friendly and powerful LCD interface



1  
1



## 2 Specifications

2-1 Technical Specifications				EWAQ080DAYN	EWAQ100DAYN	EWAQ130DAYN	EWAQ150DAYN	EWAQ180DAYN	EWAQ210DAYN	EWAQ240DAYN	EWAQ260DAYN	
Cooling capacity	Nom.		kW	80 (1)	105 (1)	131 (1)	152 (1)	182 (1)	209 (1)	236 (1)	254 (1)	
Capacity steps			%	0-50-100		0-25-50-75-100		21/29-43/50/ 57-71/79-100	0-25-50- 75-100	22/28-40/50/ 56-72/78-100	0-25-50- 75-100	
Power input	Cooling	Nom.	kW	26.4 (2)	36.2 (2)	46.6 (2)	56.3 (2)	64.5 (2)	74.6 (2)	82.8 (2)	94.0 (2)	
EER				3.03	2.90	2.81	2.70	2.82	2.80	2.85	2.70	
ESEER				4.12	4.00	4.34	4.22	4.36	4.32	4.20	4.00	
Casing	Material			Polyester painted galvanised steel plate								
Dimensions	Unit	Height	mm	2,311								
		Width	mm	2,000								
		Depth	mm	2,566		2,631		3,081		4,850		
Weight	Unit		kg	1,350	1,400	1,500	1,550	1,800	1,850	3,150	3,250	
	Operation weight		kg	1,365	1,415	1,517	1,569	1,825	1,877	3,189	3,292	
	Packed unit		kg	1,400	1,450	1,550	1,600	1,850	1,900	3,200	3,300	
Water heat exchanger	Type			Brazen plate								
	Filter	Type		Strainer galvanized								
		Diameter perforations		mm	1							
	Minimum water volume in the system		l	358 (3)	470 (3)	295 (3)	341 (3)	408 (3)	468 (3)	529 (3)	569 (3)	
	Water flow rate	Min.	l/min	115	151	188	218	261	300	339	364	
		Max.	l/min	459	602	754	871	1,043	1,198	1,355	1,456	
	Nominal water flow	Cooling		l/min	229	301	377	436	522	599	677	728
		Nominal water pressure drop	Cooling	Total	kPa	59	58	52	49	52	53	51
	Insulation material			Foamed synthetic elastomer								
Model	Type			PT120		DV47		DV58				
	Quantity			1								
Air heat exchanger	Type			Cross fin coil/Hi-Xss tubes and poly ethylene coated waffle fins								
	Rows	Quantity		2		3						
	Stages	Quantity		56		48	56			48		
	Fin pitch		mm	1.8								
	Face area		m <sup>2</sup>	2.46		2.11	2.46	3.02		2.11		
	Coils	Quantity		4				8				
Hydraulic components	Unit water volume		l	15		17	19	25	27	39	42	
	Nominal water pressure drop unit	Cooling	kPa	66	67	64	63	72	79	83	85	
Fan		Quantity			4				6		8	
	Air flow rate	Nom.	m <sup>3</sup> /min	780		800	860	1,290		1,600		
	Discharge direction			Vertical								
	Speed		rpm	880		900	970			900		
Fan motor	Output		W	500		600	700			600		
	Quantity			4				6		8		
	Drive			Direct drive								
Sound power level	Cooling	Nom.	dBA	86		88	89	90		91		
Compressor	Type			Scroll compressor								
	Quantity			2		4		2	4	2	4	
	Model			SJ180	SJ240	SJ161	SJ180		SJ240		SJ300	
	Speed		rpm	2,900								
	Oil	Charged volume	l	6.7		3.3		6.7				
Compressor 2	Quantity			-				2	-	2	-	
	Model			-				SJ240	-	SJ300	-	
	Speed		rpm	-				2,900	-	2,900	-	
	Oil	Charged volume	l	-				6.7	-	6.7	-	
Operation range	Water side	Cooling	Min.	°CDB		-10						
			Max.	°CDB		25						
	Air side	Cooling	Min.	°CDB		-15						
			Max.	°CDB		43						

1  
2

## 2 Specifications

2-1 Technical Specifications			EWAQ080DAYN	EWAQ100DAYN	EWAQ130DAYN	EWAQ150DAYN	EWAQ180DAYN	EWAQ210DAYN	EWAQ240DAYN	EWAQ260DAYN	
Refrigerant	Type	R-410A									
	Charge	kg	33	19	25	29	28	39			
	Control	Electronic expansion valve									
	Circuits	Quantity	1	2							
Refrigerant oil	Type	FVC68D									
Piping connections	Water heat exchanger inlet / outlet	3" OD							3"		
	Water heat exchanger drain	1/2"G									
Safety devices	Item	01	High pressure switch								
		02	Pressure relief valve								
		03	Low pressure safety								
		04	Freeze up protection								
		05	Flowswitch								
		06	Discharge temperature protector								
		07	Reverse phase protector								
		08	Electronic protection module compressors (only for SJ180, SJ240)								
		09	Overcurrent relays for compressors and fans								

2-2 Electrical Specifications			EWAQ080DAYN	EWAQ100DAYN	EWAQ130DAYN	EWAQ150DAYN	EWAQ180DAYN	EWAQ210DAYN	EWAQ240DAYN	EWAQ260DAYN		
Compressor	Starting current	A	195	215	158	195	215	260				
	Nominal running current (RLA)	A	25	31	19	25	31	40				
	Maximum running current	A	39	51	35	39	51	65				
	Starting method	Direct on line										
	Crankcase heater	W	75	65	75							
Compressor 2	Starting current	A	-				215	-	260	-		
	Nominal running current (RLA)	A	-				31	-	40	-		
	Maximum running current	A	-				51	-	65	-		
	Starting method	-					Direct on line	-	Direct on line	-		
	Crankcase heater	W	-				75	-	75	-		
Power supply	Phase	3~										
	Frequency	Hz	50									
	Voltage	V	400									
	Voltage range	Min.	%	-10								
		Max.	%	10								
Unit	Starting current	A	201	221	161	199	221	266				
	Maximum starting current	A	240	272	269	320	357	368	426	468		
	Current	Zmax	List	No requirements								
	Nominal running current (RLA)	Cooling	A	60	72	88	113	131	144	162	181	
		Maximum running current	A	96	120	160	177	209	233	262	290	
	Recommended fuses according to IEC standard 269-2			3 x 125gL	3 x 160gL	3 x 200gL		3 x 250gL		3 x 300gL	3 x 355gL	
Fans	Starting method	Direct on line										
	Maximum running current	A	1.5	1.4	2.1			1.6				
Control circuit	Phase	1~										
	Frequency	Hz	50									
	Voltage	V	230 (6)									

### Notes

- (1) Cooling: entering evaporator water temp. 12°C; leaving evaporator water temp. 7°C; ambient air temp. 35°C; standard: Eurovent
- (2) Cooling: entering evaporator water temp. 12°C; leaving evaporator water temp. 7°C; ambient air temp. 35°C; standard: Eurovent; Power input compressors + fans + electrical circuit
- (3) Minimum required water volume for standard thermostat settings and at nominal conditions.
- (4) Initial starting current = maximum running current 4 fans + starting current 1 compressor
- (5) Maximum starting current = maximum running current 4 fans + maximum running current 1 compressor + starting current 1 compressor
- (6) Supplied by factory installed transformers
- (7) See separate drawing for operation range
- (8) Maximum starting current = maximum running current 4 fans + maximum running current 3 compressors + starting current 1 compressor
- (9) Initial starting current = maximum running current 3 fans (1 circuit) + starting current 1 compressor
- (10) Maximum starting current = maximum running current 6 fans + maximum running current 3 compressors + starting current 1 compressor
- (11) Maximum starting current = maximum running current 8 fans + maximum running current 3 compressors + starting current 1 compressor

### 3 Options

#### 3 - 1 Options

Content : 2 counterpipes for welding onto fieldpiping

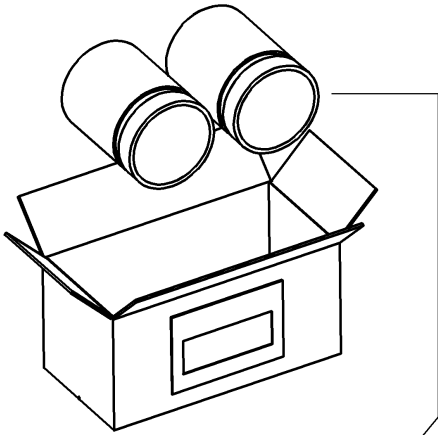

	Weight
EKGN210	2.0 kg
EKGN260	2.5 kg

Box : 200 x 100 x 100

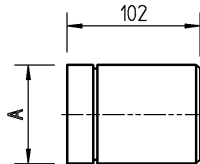

\* Material : Blank steel  
\* Ps = 10 bar

	Ø	A
EKGN210	3" OD	76.1
EKGN260	3"	88.9

EWA/YQ080DAYN*	3" OD
EWA/YQ100DAYN*	
EWA/YQ130DAYN*	
EWA/YQ150DAYN*	
EWA/YQ180DAYN*	
EWA/YQ210DAYN*	3"
EWAQ240DAYN*	
EWAQ260DAYN*	
EWYQ230DAYN*	
EWYQ250DAYN*	

Mounting instructions :

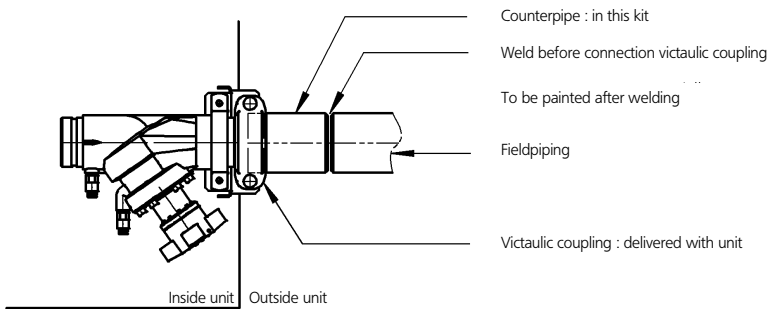

4TW58009-1

# 3 Options

## 3 - 1 Options

### Optional equipment for EWAQ-DAYN

Capacity: 080-260 kW

EWAQ080DAYNN EWAQ150DAYNN EWAQ240DAYNN  
 EWAQ100DAYNN EWAQ180DAYNN EWAQ260DAYNN  
 EWAQ130DAYNN EWAQ210DAYNN

Option number	Option description	Unit size								Availability
		080	100	130	150	180	210	240	260	
	Standard unit	0	0	0	0	0	0	0	0	
OPSC	Single pump contactor	0	0	0	0	0	0	0	0	Factory mounted
OPTC	Twin pump contactor	0	0	0	0	0	0	0	0	Factory mounted
OPSP	Single pump	0	0	0	0	0	0	0	0	Factory mounted
OPTP	Twin pump (1 pump house, dual motor)	0	0	0	0	0	0	0	0	Factory mounted
OPHP	high ESP pump (single pump only)	0	0	0	0	0	0	0	0	Factory mounted
OPBT	Buffer tank	0	0	0	0	0	0	0	0	Factory mounted
OPIF	Inverter fans for low ambient (-15 °C)	0	0	0	0	0	0	0	0	Factory mounted
OPZL	Glycol 0°C-10°C	0	0	0	0	0	0	0	0	Factory mounted
OPD3	Dual pressure relief valve	0	0	0	0	0	0	0	0	Factory mounted
OP10	evaporator heater tape	0	0	0	0	0	0	0	0	Factory mounted
OP12	option valves (discharge-, liquid line- and suction stop valve)	0 (S)	0 (S)	0 (S)	0 (S)	0 (S)	0 (S)	0 (S)	0 (S)	Factory mounted
OPS7	A-meter, V-meter	0	0	0	0	0	0	0	0	Factory mounted
OPLN	Low noise = OPIF + compressorhousing	0	0	0	0	0	0	0	0	Factory mounted
OPCG	Condenser protection grilles	0	0	0	0	0	0	0	0	Factory mounted
<b>Available kits</b>										
EKLONPG	Gateway for LON*	0	0	0	0	0	0	0	0	Kit
EKBNPG	Gateway for BACNET*	0	0	0	0	0	0	0	0	Kit
EKACPG	Address card including	0	0	0	0	0	0	0	0	Kit
Daikin Integrated Chiller Network (DICON)										
Serial Communication (Modbus)										
EKRUPG	Remote user interface	0	0	0	0	0	0	0	0	Kit
EKGN210	Waterpipe kit	0	0	0	0	0	0	-	-	Kit
EKGN260	Waterpipe kit	-	-	-	-	-	-	0	0	Kit

**Notes**

- o Available
- Not available
- (S) option required for swedish national law SNFS1992:16

\* To install EKLONPG & EKBNPG => EKACPG needs to be installed on the unit.  
 For the EKLONPG & EKBNPG design guide, please contact your local dealer.

3TW57579-8B

### EWAQ080-100DAYN

TECHNICAL SPECIFICATIONS OPTIONS									
OPSP		EWAQ080DAYN		EWAQ100DAYN		OPSP + OPBT		EWAQ100DAYN	
<b>Units</b>									
Weight	Additional machine weight	kg	250		300				
	Additional operation weight	kg	283		523				
	Additional gross weight	kg	250		300				
<b>Pump</b>				Single stage in line pumps		Single stage in line pumps			
Hydraulic components	Type		1		1				
	Quantity		1		1				
	Manufacturer		Grundfos		Grundfos				
	Model		TP50-240/2		TP50-240/2				
	Efficiency		85.9%		85.9%				
	Efficiency level		IE3		IE3				
	Rated speed	rpm	2890-2910		2890-2910				
	Nominal static height unit	kPa	142	133		142	133		
Hydraulic components	Buffertank	l	-		190				
	Additional unit water volume	l	33		223				
	Expansion vessel	l	35		35				
	Pre-charge pressure exp. vessel	bar	1.5		1.5				
Safety valve	bar	3		3					
<b>OPHP</b>		EWAQ080DAYN		EWAQ100DAYN		<b>OPTP</b>		EWAQ100DAYN	
<b>Units</b>									
<b>Pump</b>				Single stage in line pumps		Single stage in line pumps			
Hydraulic components	Type		1		1				
	Quantity		1		1				
	Manufacturer		Grundfos		Grundfos				
	Model		TP50-430/2		TP50-240/2				
	Efficiency		89.2%		85.9%				
	Efficiency level		IE3		IE3				
	Rated speed	rpm	2920-2940		2890-2910				
	Nominal static height unit	kPa	337	322		See OPSP			

3TW57571-1E

### 3 Options

#### 3 - 1 Options

##### EWAQ080-100DAYN

ELECTRICAL SPECIFICATIONS OPTIONS				
OPSP / OPTP		EWAQ080DAYN		EWAQ100DAYN
<b>Units</b>				
Std pump	Starting method	Direct on-line		
	Rated power output	kW	2.2	
	Maximum running current	A	4.5	
	Starting current	A	42	
<b>OPHP</b>				
<b>Units</b>		EWAQ080DAYN		EWAQ100DAYN
High ESP pump	Starting method	Direct on-line		
	Rated power output	kW	5.5	
	Maximum running current	A	11.2	
	Starting current	A	131	
<b>OP10</b>				
<b>Units</b>		EWAQ080DAYN		EWAQ100DAYN
Heater tape	Supply voltage	V	230+/-10%	
	Recommended fuses	A	2x10	
	Power standard model	W	1x300	
	Power model with pump	W	2x300	
	Power model with pump and buffertank	W	2x300 + 1x150	

3TW57571-1E

##### EWAQ130-150DAYN

TECHNICAL SPECIFICATIONS OPTIONS						
OPSP			EWAQ130DAYN		EWAQ150DAYN	
<b>Units</b>						
Weight	Additional machine weight	kg	250		300	
	Additional operation weight	kg	286		526	
	Additional gross weight	kg	250		300	
Pump	Type	Single stage in line pumps				
	Quantity	1				
	Manufacturer	Grundfos				
	Model	TP65-230/2				
	Efficiency	87.1%				
	Efficiency level	IE3				
	Rated speed	rpm	2900-2920		2900-2920	
	Nominal static height unit	kPa	134	126		134
Hydraulic components	Buffertank	l	-		190	
	Additional unit water volume	l	36		226	
	Expansion vessel	l	35		35	
	Pre-charge pressure exp. vessel	bar	1.5		1.5	
	Safety valve	bar	3		3	
<b>OPHP</b>						
<b>Units</b>		EWAQ130DAYN		EWAQ150DAYN		
Pump	Type	Single stage in line pumps				
	Quantity	1				
	Manufacturer	Grundfos				
	Model	TP65-340/2				
	Efficiency	89.2%				
	Efficiency level	IE3				
	Rated speed	rpm	2920-2940		2900-2920	
	Nominal static height unit	kPa	253	248		See OPSP
<b>OPTP</b>						
<b>Units</b>		EWAQ130DAYN		EWAQ150DAYN		
Single stage in line pumps						
1						
Grundfos						
TPD65-230/2						
87.1%						
IE3						
2900-2920						

3TW57591-1D

### 3 Options

#### 3 - 1 Options

##### EWAQ130-150DAYN

ELECTRICAL SPECIFICATIONS OPTIONS				
OPSP / OPTP		EWAQ130DAYN		EWAQ150DAYN
<b>Units</b>				
Std pump	Starting method	Direct on-line		
	Rated power output	kW	3	
	Maximum running current	A	6.3	
	Starting current	A	58	
<b>OPHP</b>				
<b>Units</b>		EWAQ130DAYN		EWAQ150DAYN
High ESP pump	Starting method	Direct on-line		
	Rated power output	kW	5.5	
	Maximum running current	A	11.2	
	Starting current	A	131	
<b>OP10</b>				
<b>Units</b>		EWAQ130DAYN		EWAQ150DAYN
Heater tape	Supply voltage	V	230+/-10%	
	Recommended fuses	A	2x10	
	Power standard model	W	1x300	
	Power model with pump	W	2x300	
	Power model with pump and buffertank	W	2x300 + 1x150	

3TW57591-1D

##### EWAQ180-210DAYN

TECHNICAL SPECIFICATIONS OPTIONS						
OPSP			EWAQ180DAYN		EWAQ210DAYN	
<b>Units</b>						
Weight	Additional machine weight	kg	250			
	Additional operation weight	kg	286			
	Additional gross weight	kg	250			
Pump	Type	Single stage in line pumps				
	Quantity	1				
	Manufacturer	Grundfos				
	Model	TP65-260/2				
	Efficiency	88.1%				
	Efficiency level	IE3				
	Rated speed	rpm	2920-2940			
	Nominal static height unit	kPa	142		120	
Hydraulic components	Buffertank	l	-			
	Additional unit water volume	l	36			
	Expansion vessel	l	35			
	Pre-charge pressure exp. vessel	bar	1.5			
	Safety valve	bar	3			
<b>OPSP + OPBT</b>						
<b>Units</b>		EWAQ180DAYN		EWAQ210DAYN		
Weight		300		526		
Additional operation weight		300		300		
Type		Single stage in line pumps				
Quantity		1				
Manufacturer		Grundfos				
Model		TP65-260/2				
Efficiency		88.1%				
Efficiency level		IE3				
Rated speed		2920-2940				
Nominal static height unit		142		120		
Buffertank		190				
Additional unit water volume		226				
Expansion vessel		35				
Pre-charge pressure exp. vessel		1.5				
Safety valve		3				
<b>OPTP</b>						
<b>Units</b>		EWAQ180DAYN		EWAQ210DAYN		
Pump	Type	Single stage in line pumps				
	Quantity	1				
	Manufacturer	Grundfos				
	Model	TPD65-260/2				
	Efficiency	88.1%				
	Efficiency level	IE3				
	Rated speed	rpm	2910-2920			
	Nominal static height unit	kPa	296		278	
		See OPSP				

3TW57611-1D

1

3

### 3 Options

#### 3 - 1 Options

##### EWAQ180-210DAYN

ELECTRICAL SPECIFICATIONS OPTIONS			
OPSP / OPTP		Units	
		EWAQ180DAYN	EWAQ210DAYN
Std pump	Starting method	Direct on-line	
	Rated power output	4	
	Maximum running current	8	
	Starting current	98	
OPHP		Units	
		EWAQ180DAYN	EWAQ210DAYN
High ESP pump	Starting method	Direct on-line	
	Rated power output	7.5	
	Maximum running current	15.2	
	Starting current	169	
OP10		Units	
		EWAQ180DAYN	EWAQ210DAYN
Heater tape	Supply voltage	230+/-10%	
	Recommended fuses	2x10	
	Power standard model	1x300	
	Power model with pump	2x300	
	Power model with pump and buffertank	2x300 + 1x150	

3TW57611-1D

##### EWAQ240-260DAYN

TECHNICAL SPECIFICATIONS OPTIONS					
OPSP			Units		
			EWAQ240DAYN	EWAQ260DAYN	
Weight	Additional machine weight	kg	250		300
	Additional operation weight	kg	271		511
	Additional gross weight	kg	250		300
Pump	Type	Single stage in line pumps			
	Quantity	1			
	Manufacturer	Grundfos			
	Model	TP65-260/2			
	Efficiency	88.1%			
	Efficiency level	IE3			
	Rated speed	rpm	2920-2940		
	Nominal static height unit	kPa	126	117	126
Hydraulic components	Buffertank	l	-		
	Additional unit water volume	l	21		
	Expansion vessel	l	50		
	Pre-charge pressure exp. vessel	bar	1.5		
	Safety valve	bar	3		
OPHP			Units		
			EWAQ240DAYN	EWAQ260DAYN	
Pump	Type	Single stage in line pumps			
	Quantity	1			
	Manufacturer	Grundfos			
	Model	TP65-410/2			
	Efficiency	90.4%			
	Efficiency level	IE3			
	Rated speed	rpm	2910-2920		
	Nominal static height unit	kPa	288	280	
OPSP + OPBT			Units		
			EWAQ240DAYN	EWAQ260DAYN	
Pump	Type	Single stage in line pumps			
	Quantity	1			
	Manufacturer	Grundfos			
	Model	TPD65-260/2			
	Efficiency	88.1%			
	Efficiency level	IE3			
	Rated speed	rpm	2920-2940		
	Nominal static height unit	kPa	126	117	126
OPTP			Units		
			EWAQ240DAYN	EWAQ260DAYN	
Pump	Type	Single stage in line pumps			
	Quantity	1			
Pump	Manufacturer	Grundfos			
	Model	TPD65-260/2			
Pump	Efficiency	88.1%			
	Efficiency level	IE3			
Pump	Rated speed	rpm	2920-2940		
	Nominal static height unit	kPa	See OPSP		

3TW57631-1C

### 3 Options

#### 3 - 1 Options

EWAQ240-260DAYN

ELECTRICAL SPECIFICATIONS OPTIONS				
OPSP / OPTP		EWAQ240DAYN		EWAQ260DAYN
<b>Units</b>				
Std pump	Starting method	Direct on-line		
	Rated power output	kW	4	
	Maximum running current	A	8	
	Starting current	A	98	
<b>OPHP</b>				
<b>Units</b>				
High ESP pump	Starting method	Direct on-line		
	Rated power output	kW	7.5	
	Maximum running current	A	15.2	
	Starting current	A	169	
<b>OP10</b>				
<b>Units</b>				
Heater tape	Supply voltage	V	230+/-10%	
	Recommended fuses	A	2x10	
	Power standard model	W	1x300	
	Power model with pump	W	2x300	
	Power model with pump and buffertank	W	2x300 + 1x150	

3TW57631-1C

1

3



# 4 Capacity tables

## 4 - 1 Cooling Capacity Tables

### EWAQ-DAYN

STANDARD													
Tamb (°C)		20		25		30		35		40		43	
LWE	Size	CC	PI	CC	PI	CC	PI	CC	PI	CC	PI	CC	PI
4	080	83.6	20.3	79.9	22.0	76.2	23.9	72.2	26.1	67.9	28.5	65.2	30.2
	100	110	27.0	105	29.5	100	32.3	94.9	35.5	89.0	39.0	85.2	41.4
	130	138	34.8	132	38.0	126	41.5	119	45.5	111	49.9	106	52.9
	150	164	42.2	156	46.1	147	50.5	138	55.4	128	60.9	122	64.5
	180	191	48.5	183	52.9	174	57.9	164	63.4	154	69.7	148	73.8
	210	225	56.8	214	61.4	203	66.6	191	73.1	178	80.4	169	85.2
	240	252	62.4	240	68.0	228	74.3	215	81.3	201	89.1	191	94.3
260	267	71.3	256	77.6	244	84.6	230	92.3	215	101	206	107	
7	080	92.3	20.6	88.4	22.3	84.4	24.3	80.0	26.4	75.3	28.9	72.3	30.5
	100	122	27.7	117	30.2	111	33.0	105	36.2	98.4	39.7	94.2	42.1
	130	153	35.8	146	39.1	139	42.6	131	46.6	123	51.0	117	54.0
	150	180	43.2	171	47.1	162	51.5	152	56.3	141	62.0	134	65.6
	180	211	49.5	202	54.0	192	58.9	182	64.5	171	70.8	163	74.9
	210	246	58.2	234	62.8	222	68.0	209	74.6	195	81.9	186	86.7
	240	276	63.7	264	69.4	251	75.7	236	82.8	220	90.7	210	95.9
260	295	72.7	282	79.1	269	86.2	254	94.0	237	103	227	108	
10	080	102	20.9	97.6	22.7	93.2	24.6	88.4	26.8	83.3	29.3	80.0	30.9
	100	134	28.5	128	31.0	122	33.8	116	36.9	108	40.5	104	42.8
	130	168	36.9	161	40.2	153	43.8	144	47.8	135	52.2	129	55.2
	150	198	44.3	188	48.3	178	52.7	167	57.7	155	63.3	147	66.9
	180	233	50.7	223	55.1	212	60.1	201	65.7	188	72.0	180	76.1
	210	269	59.8	256	64.4	243	69.6	228	76.2	213	83.5	203	88.3
	240	303	65.3	289	71.0	275	77.3	259	84.5	241	92.4	230	97.6
260	325	74.3	311	80.8	296	87.9	279	95.9	261	105	249	110	
13	080	112	21.3	108	23.1	103	25.1	97.5	27.3	91.8	29.7	88.2	31.3
	100	147	29.4	141	31.8	134	34.6	127	37.8	119	41.3	114	43.6
	130	185	38.1	177	41.5	168	45.1	158	49.0	148	53.5	141	56.5
	150	216	45.4	206	49.5	194	54.1	182	59.1	169	64.7	161	68.4
	180	256	52.0	245	56.4	233	61.4	221	67.0	207	73.3	198	77.5
	210	293	61.7	279	66.2	265	71.4	249	77.9	232	85.3	221	90.1
	240	331	67.0	317	72.7	300	79.1	283	86.3	264	94.2	252	99.4
260	356	76.1	341	82.6	325	89.8	306	97.8	286	107	273	112	
16	080	123	21.7	118	23.5	113	25.5	107	27.7	101	30.2	96.9	31.8
	100	161	30.4	154	32.8	147	35.5	139	38.7	130	42.2	125	44.5
	130	203	39.4	193	42.7	184	46.4	173	50.4	161	54.9	154	57.9
	150	235	46.7	224	50.9	211	55.5	198	60.6	184	66.3	176	69.9
	180	281	53.4	269	57.9	256	62.9	242	68.5	227	74.8	217	79.0
	210	318	63.7	304	68.2	288	73.3	271	79.9	252	87.2	241	92.0
	240	362	68.9	345	74.7	328	81.1	309	88.3	288	96.2	275	101.4
260	390	78.0	373	84.6	355	91.9	335	99.9	313	109	299	115	
20	080	139	22.4	133	24.2	127	26.2	121	28.5	114	30.9	108	32.1
	100	180	31.8	173	34.2	164	36.9	155	40.0	146	43.5	140	45.5
	130	227	41.1	217	44.5	206	48.3	193	52.3	180	56.9	172	59.5
	150	262	48.6	249	52.9	235	57.7	220	62.9	204	68.6	194	71.5
	180	315	55.6	302	60.1	287	65.1	271	70.7	254	77.1	243	80.5
	210	354	66.7	338	71.2	320	76.2	301	82.8	281	90.1	268	94.0
	240	405	71.8	386	77.6	366	84.0	345	91.2	322	99.2	306	104.5
260	438	80.8	419	87.5	398	94.9	375	103	350	112	333	114.5	

### SYMBOLS

- CC : Cooling capacity (kW)
- PI : Power input (kW)
- LWE : Leaving Water Evaporator temperature (°C)
- Tamb : Ambient temperature (°C)

### NOTES

1. Cooling capacity (kW)  
Capacity is according to Eurovent rating standard 6/C/003-2006 and valid for chilled water range  $\Delta t = 3 - 8^\circ\text{C}$
2. Power input (kW)  
Power input is total input according to Eurovent rating standard 6/C/003-2006: Compressor + fans + control circuit
3. For units with integrated heat pump  
Values for CC are to be multiplied by 0.99 in order to compensate heat input of the pump
4. Additional ESP can be added to the fans discharge  
The following impact on the performance has to be considered

ESP (Pa)	CC (%)	PI (%)
25	99	101
50	98	103
75	96	105

Where  
ESP = External static pressure applied at nominal unit airflow.

3TW57572-1D

# 4 Capacity tables

## 4 - 1 Cooling Capacity Tables

EWAQ-DAYN

OPZL													
Tamb (°C)		20		25		30		35		40		43	
LWE	Size	CC	PI	CC	PI	CC	PI	CC	PI	CC	PI	CC	PI
-10	080	52.8	19.2	49.7	21.0	46.7	23.0	43.8	25.2	40.7	27.8		
	100	67.7	24.8	64.3	27.3	60.9	30.0	57.3	33.0	53.6	36.4		
	130	88.1	31.0	83.8	34.1	79.4	37.6	74.6	41.6	69.5	46.1		
	150	100	38.7	93.6	42.6	87.7	46.9	81.8	51.8	75.6	57.4		
	180	117	45.2	111	49.6	105	54.4	98.2	59.9	91.6	66.1		
	210	143	51.9	136	56.5	128	61.5	120	67.7	111	74.7		
	240	163	57.7	155	63.0	146	69.0	137	75.7	127	83.2		
260	170	66.1	162	72.0	153	78.6	144	86.0	134	94			
-7	080	58.0	19.4	54.9	21.2	51.9	23.1	48.8	25.3	45.6	27.8		
	100	75.2	25.2	71.6	27.7	67.9	30.4	64.0	33.5	59.9	36.9		
	130	96.7	31.6	92.2	34.8	87.5	38.3	82.4	42.2	76.9	46.8		
	150	111	39.3	105	43.1	99.0	47.4	92.5	52.3	85.8	57.8		
	180	130	45.7	123	50.1	117	55.0	110	60.5	103	66.7		
	210	158	52.7	150	57.3	142	62.4	133	68.8	124	75.8		
	240	179	58.5	170	63.9	161	70.0	151	76.8	141	84.4		
260	187	67.1	178	73.0	169	79.7	160	87.2	149	96			
-5	080	61.9	19.5	58.8	21.3	55.7	23.2	52.5	25.4	49.1	27.9	47.0	29.5
	100	80.6	25.4	76.8	27.9	73.0	30.7	68.9	33.8	64.5	37.3	61.7	39.6
	130	103	32.1	98.3	35.3	93.4	38.8	88.1	42.7	82.3	47.2	78.5	50.3
	150	133	39.7	113	43.5	107	47.8	100	52.7	92.9	58.2	88.3	61.8
	180	140	46.1	133	50.5	126	55.4	119	60.9	111	67.1	106	71.2
	210	169	53.3	161	58.0	152	63.1	142	69.5	132	76.6	126	81.3
	240	190	59.1	181	64.6	172	70.7	161	77.5	150	85.2	143	90.2
260	199	67.7	190	73.7	181	80.5	171	88.0	159	96	152	102	
-2	080	68.4	19.7	65.1	21.5	61.8	23.4	58.4	25.6	54.8	28.1	52.6	29.7
	100	89.6	25.9	85.5	28.4	81.3	31.2	76.8	34.3	72.0	37.8	68.9	40.1
	130	113	32.9	108	36.1	103	39.6	97.3	43.5	91.0	48.0	86.9	51.0
	150	133	40.4	127	44.3	119	48.5	112	53.4	104	58.9	99.0	62.5
	180	155	46.8	148	51.2	140	56.1	133	61.7	124	67.9	119	72.0
	210	186	54.3	177	59.0	167	64.1	157	70.6	146	77.8	140	82.5
	240	209	60.0	199	65.6	189	71.8	178	78.7	166	86.4	158	91.5
260	219	68.8	210	74.9	200	81.7	189	89.3	176	98	168	103	
2	080	78.1	20.1	74.7	21.8	71.1	23.8	67.3	25.9	63.3	28.4	60.8	30.0
	100	103	26.6	98.4	29.1	93.6	31.9	88.5	35.1	83.0	38.6	79.5	40.9
	130	129	34.1	124	37.3	118	40.8	111	44.8	104	49.2	99.3	52.2
	150	153	41.5	145	45.4	138	49.7	129	54.5	120	60.0	114	63.7
	180	178	47.9	170	52.3	162	57.2	153	62.8	144	69.0	137	73.1
	210	211	55.9	201	60.5	190	65.7	179	72.2	167	79.5	159	84.3
	240	236	61.5	226	67.1	214	73.4	202	80.4	188	88.2	180	93.3
260	250	70.4	240	76.6	228	83.5	216	91.3	202	100	192	106	

### SYMBOLS

- CC : Cooling capacity (kW)
- PI : Power input (kW)
- LWE : Leaving Water Evaporator temperature (°C)
- Tamb : Ambient temperature (°C)

### NOTES

1. Cooling capacity (kW)  
Capacity is according to Eurovent rating standard 6/C/003-2006 and valid for chilled water range Dt = 3 - 8°C
2. Power input (kW)  
Power input is total input according to Eurovent rating standard 6/C/003-2006: Compressor + fans + control circuit
3. For units with integrated heat pump  
Values for CC are to be multiplied by 0.99 in order to compensate heat input of the pump
4. Usage of glycol and other anti-freeze  
Correction factors for CC and PI are applicable according type and concentration of the used anti-freeze

3TW57572-1D

# 4 Capacity tables

## 4 - 2 Capacity Correction Factor

Required glycol concentration

Type	Concentration (wt%)	0	10	20	30	40
Ethylene glycol	Freezing point °C	0	-4	-9	-16	-23
	Minimum LWE °C	4	2	0	-5	-11
Propylene glycol	Freezing point °C	0	-3	-7	-13	-22
	Minimum LWE °C	4	3	-2	-4	-10

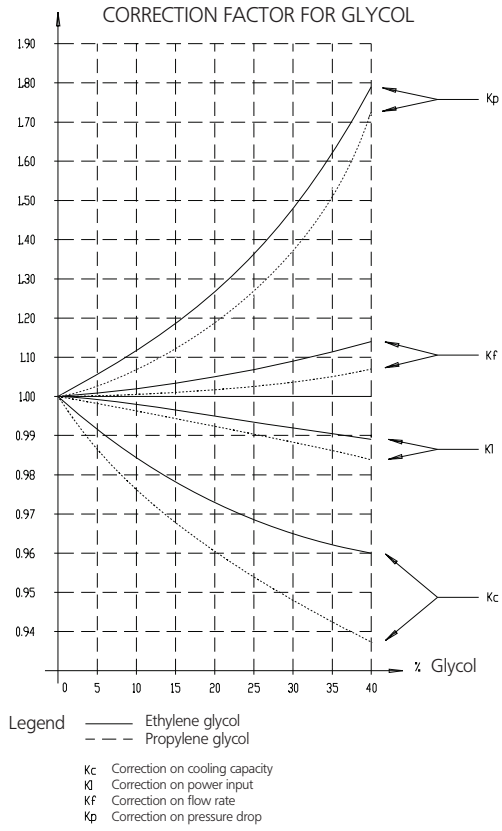

# 5 Dimensional drawings

## 5 - 1 Dimensional Drawings

1  
5

### EWAQ080-100DAYN(P-B)

- 01 Evaporator
- 02 Condensor
- 03 Compressor
- 04 Expansion valve + sight glass
- 05 Discharge stopvalve (Optional)
- 06 Suction stopvalve (Optional)
- 07 Liquid stopvalve (Optional)
- 08 Chilled water IN (Victaulic coupling)
- 09 Chilled water OUT (Victaulic coupling)
- 10 Water drain evaporator
- 11 Air purge
- 12 Leaving water temperature sensor
- 13 Entering water temperature sensor
- 14 Ambient temperature sensor
- 15 Drier + charge valve
- 16 Power supply intake
- 17 Switchbox
- 18 Digital display controller (Inside switchbox)
- 19 Field wiring intake

- 20 Main isolator switch
- 21 Transport beam
- 22 Flowswitch
- 23 Fan
- 24 Safety valve
- 25 High pressure sensor
- 26 Low pressure sensor
- 27 High pressure switch
- 28 Oil sight glass
- 29 Pump (optional)
- 30 Buffertank (optional)
- 31 Expansion vessel (optional)
- 32 Waterfilter
- 33 Water stopvalve (optional)
- 34 Frame
- 35 Buffertank drain valve (optional)
- 36 Regulating valve (optional)
- 37 Water safety valve (optional)
- 38 Pressure gauge (optional)

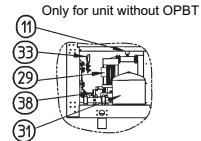
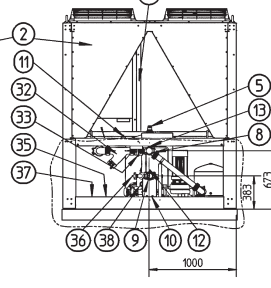
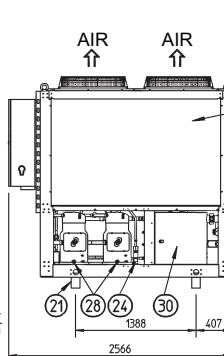
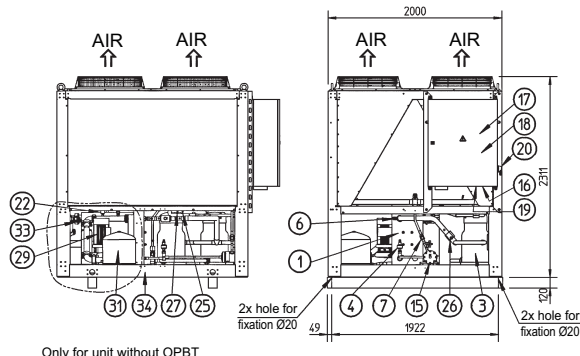
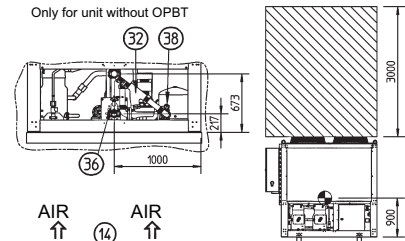
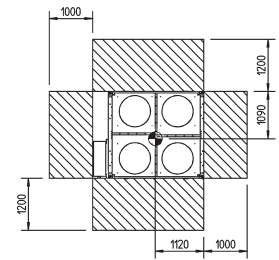
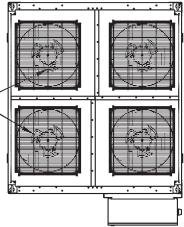

**Legend**  
 [Hatched area] Required space around the unit for service and air intake  
 [Circle with dot] Center of gravity

3TW57574-1A

### EWAQ080-100DAYN(N)

- 01 Evaporator
- 02 Condensor
- 03 Compressor
- 04 Expansion valve + sight glass
- 05 Discharge valve (Optional)
- 06 Suction stopvalve (Optional)
- 07 Liquid stopvalve (Optional)
- 08 Chilled water IN (Victaulic coupling)
- 09 Chilled water OUT (Victaulic coupling)
- 10 Water drain evaporator
- 11 Air purge
- 12 Leaving water temperature sensor
- 13 Entering water temperature sensor
- 14 Ambient temperature sensor
- 15 Drier + charge valve

- 16 Power supply intake
- 17 Switchbox
- 18 Digital display controller (Inside switchbox)
- 19 Field wiring intake
- 20 Main isolator switch
- 21 Transport beam
- 22 Flowswitch
- 23 Fan
- 24 Safety valve
- 25 High pressure sensor
- 26 Low pressure sensor
- 27 High pressure switch
- 28 Oil sight glass
- 29 Waterfilter
- 30 Frame

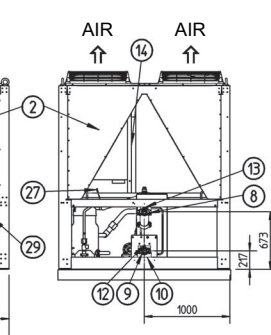
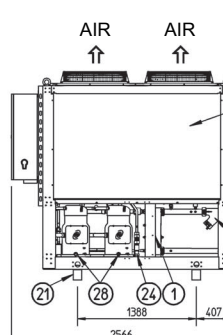
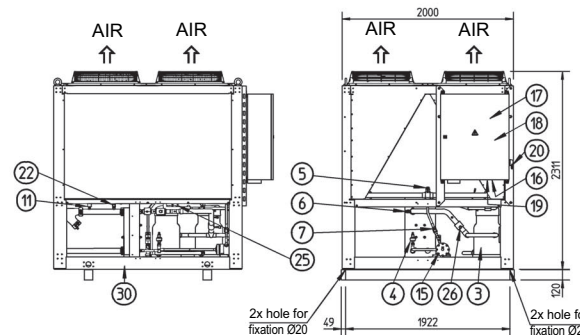
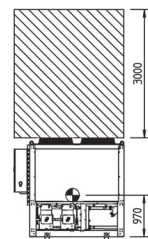
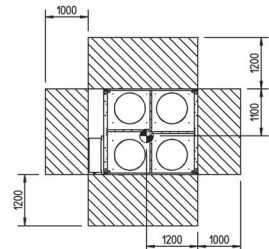
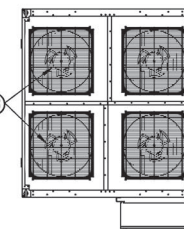

**Legend**  
 [Hatched area] Required space around the unit for service and air intake  
 [Circle with dot] Center of gravity

3TW57574-2A

# 5 Dimensional drawings

## 5 - 1 Dimensional Drawings

### EWAQ130-150DAYN(P-B)

- 01 Evaporator
- 02 Condensor
- 03 Compressor
- 04 Expansion valve + sight glass
- 05 Discharge stopvalve (Optional)
- 06 Suction stopvalve (Optional)
- 07 Liquid stopvalve (Optional)
- 08 Chilled water IN (Victaulic coupling)
- 09 Chilled water OUT (Victaulic coupling)
- 10 Water drain evaporator
- 11 Air purge
- 12 Leaving water temperature sensor
- 13 Entering water temperature sensor
- 14 Ambient temperature sensor
- 15 Drier + charge valve
- 16 Power supply intake
- 17 Switchbox
- 18 Digital display controller (Inside switchbox)
- 19 Field wiring intake
- 20 Main isolator switch

- 21 Transport beam
- 22 Flowswitch
- 23 Fan
- 24 Safety valve
- 25 High pressure sensor
- 26 Low pressure sensor
- 27 High pressure switch
- 28 Oil sight glass
- 29 Pump (Optional)
- 30 Buffertank (Optional)
- 31 Expansion vessel (Optional)
- 32 Waterfilter
- 33 Water stopvalve (Optional)
- 34 Frame
- 35 Buffertank drain valve (Optional)
- 36 Regulating valve (Optional)
- 37 Water safety valve (Optional)
- 38 Pressure gauge (Optional)

3TW57594-1B

### EWAQ130-150DAYN(N)

- 01 Evaporator
- 02 Condensator
- 03 Compressor
- 04 Expansion valve + sight glass
- 05 Discharge stopvalve (Optional)
- 06 Suction stopvalve (Optional)
- 07 Liquid stopvalve (Optional)
- 08 Chilled water IN (Victaulic coupling)
- 09 Chilled water OUT (Victaulic coupling)
- 10 Water drain evaporator
- 11 Air purge
- 12 Leaving water temperature sensor
- 13 Entering water temperature sensor
- 14 Ambient temperature sensor
- 15 Drier + charge valve

- 16 Power supply intake
- 17 Switchbox
- 18 Digital display controller (Inside switchbox)
- 19 Field wiring intake
- 20 Main isolator switch
- 21 Transport beam
- 22 Flowswitch
- 23 Fan
- 24 Safety valve
- 25 High pressure sensor
- 26 Low pressure sensor
- 27 High pressure switch
- 28 Oil sight glass
- 29 Waterfilter
- 30 Frame

3TW57594-2A



# 5 Dimensional drawings

## 5 - 1 Dimensional Drawings

### EWAQ180-210DAYN(P-B)

- 01 Evaporator
- 02 Condensor
- 03 Compressor
- 04 Expansion valve + sight glass
- 05 Discharge stopvalve (Optional)
- 06 Suction stopvalve (Optional)
- 07 Liquid stopvalve (Optional)
- 08 Chilled water IN (Victaulic coupling)
- 09 Chilled water OUT (Victaulic coupling)
- 10 Water drain evaporator
- 11 Air purge
- 12 Leaving water temperature sensor
- 13 Entering water temperature sensor
- 14 Ambient temperature sensor
- 15 Drier + charge valve
- 16 Power supply intake
- 17 Switchbox
- 18 Digital display controller (Inside switchbox)
- 19 Field wiring intake
- 20 Main isolator switch

- 21 Transport beam
- 22 Flowswitch
- 23 Fan
- 24 Safety valve
- 25 High pressure sensor
- 26 Low pressure sensor
- 27 High pressure switch
- 28 Oil sight glass
- 29 Pump (Optional)
- 30 Buffertank (Optional)
- 31 Expansion vessel (Optional)
- 32 Waterfilter
- 33 Water stopvalve (Optional)
- 34 Frame
- 35 Buffertank drain valve (Optional)
- 36 Regulating valve (Optional)
- 37 Water safety valve (Optional)
- 38 Pressure gauge (Optional)

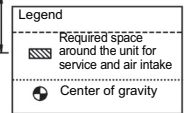
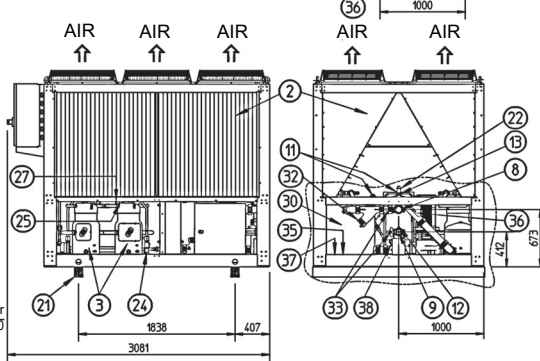
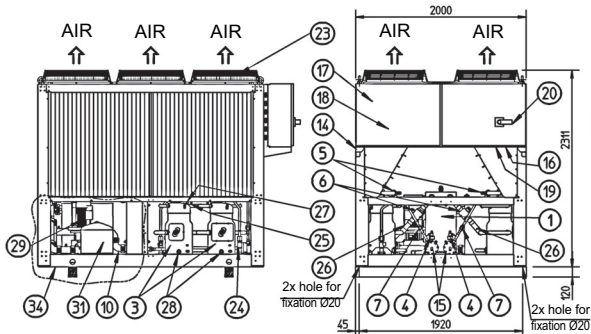
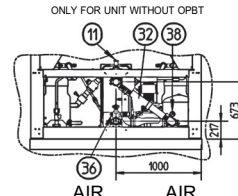
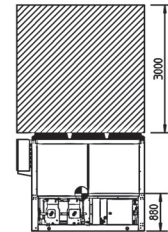
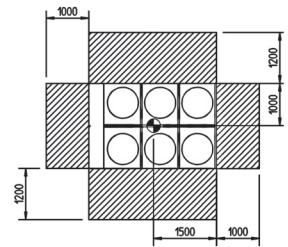
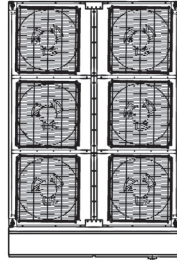

ONLY FOR UNIT WITHOUT OPBT

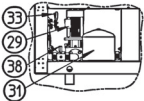

3TW57614-1B

### EWAQ180-210DAYN(N)

- 01 Evaporator
- 02 Condensor
- 03 Compressor
- 04 Expansion valve + sight glass
- 05 Discharge stopvalve (Optional)
- 06 Suction stopvalve (Optional)
- 07 Liquid stopvalve (Optional)
- 08 Chilled water IN (Victaulic coupling)
- 09 Chilled water OUT (Victaulic coupling)
- 10 Water drain evaporator
- 11 Air purge
- 12 Leaving water temperature sensor
- 13 Entering water temperature sensor
- 14 Ambient temperature sensor
- 15 Drier + charge valve

- 16 Power supply intake
- 17 Switchbox
- 18 Digital display controller (Inside switchbox)
- 19 Field wiring intake
- 20 Main isolator switch
- 21 Transport beam
- 22 Flowswitch
- 23 Fan
- 24 Safety valve
- 25 High pressure sensor
- 26 Low pressure sensor
- 27 High pressure switch
- 28 Oil sight glass
- 29 Waterfilter
- 30 Frame

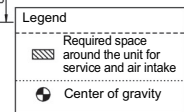
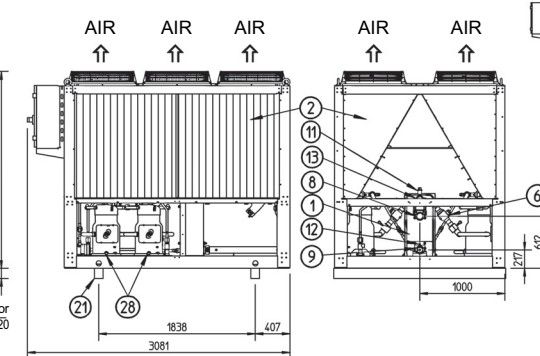
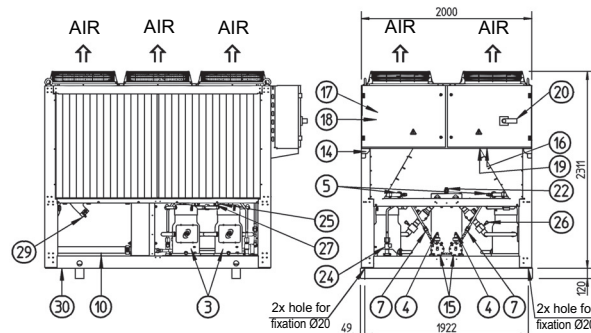
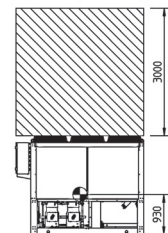
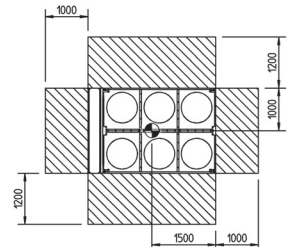
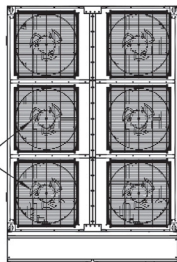

3TW57614-2A

# 5 Dimensional drawings

## 5 - 1 Dimensional Drawings

### EWAQ240-260DAYN(P-B)

- 01 Evaporator
- 02 Condensor
- 03 Compressor
- 04 Expansion valve + sight glass
- 05 Discharge stopvalve (Optional)
- 06 Suction stopvalve (Optional)
- 07 Liquid stopvalve (Optional)
- 08 Chilled water IN (Victaulic coupling)
- 09 Chilled water OUT (Victaulic coupling)
- 10 Water drain evaporator
- 11 Air purge
- 12 Leaving water temperature sensor
- 13 Entering water temperature sensor
- 14 Ambient sensor
- 15 Drier + charge valve
- 16 Power supply intake
- 17 Switchbox
- 18 Digital display controller (Inside switchbox)
- 19 Field wiring intake
- 20 Main isolator switch
- 21 Transport beam
- 22 Flowswitch
- 23 Fan
- 24 Safety valve
- 25 High pressure sensor
- 26 Low pressure sensor
- 27 High pressure switch
- 28 Oil sight glass
- 29 Waterfilter
- 30 Frame
- 31 Pump (optional)
- 32 Buffertank (optional)
- 33 Expansion vessel (optional)
- 34 Water stopvalve (optional)
- 35 Buffertank drain valve (optional)
- 36 Regulating valve (optional)
- 37 Water safety valve (optional)
- 38 Pressure gauge (optional)

**Legend**

- Required space around the unit for service and air intake
- Center of gravity

Only for unit without OPBT

Only for unit without OPBT

3TW57634-1

### EWAQ240-260DAYN(N)

- 01 Evaporator
- 02 Condensor
- 03 Compressor
- 04 Expansion valve + sight glass
- 05 Discharge stopvalve (Optional)
- 06 Suction stopvalve (Optional)
- 07 Liquid stopvalve (Optional)
- 08 Chilled water IN (Victaulic coupling)
- 09 Chilled water OUT (Victaulic coupling)
- 10 Water drain evaporator
- 11 Air purge
- 12 Leaving water temperature sensor
- 13 Entering water temperature sensor
- 14 Ambient sensor
- 15 Drier + charge valve
- 16 Power supply intake
- 17 Switchbox
- 18 Digital display controller (Inside switchbox)
- 19 Field wiring intake
- 20 Main isolator switch
- 21 Transport beam
- 22 Flowswitch
- 23 Fan
- 24 Safety valve
- 25 High pressure sensor
- 26 Low pressure sensor
- 27 High pressure switch
- 28 Oil sight glass
- 29 Waterfilter
- 30 Frame

**Legend**

- Required space around the unit for service and air intake
- Center of gravity

Only for unit without OPBT

3TW57634-2

# 6 Piping diagrams

## 6 - 1 Piping Diagrams

EWAQ-EWYQ-DAYN(N-P-B)(water piping diagram)

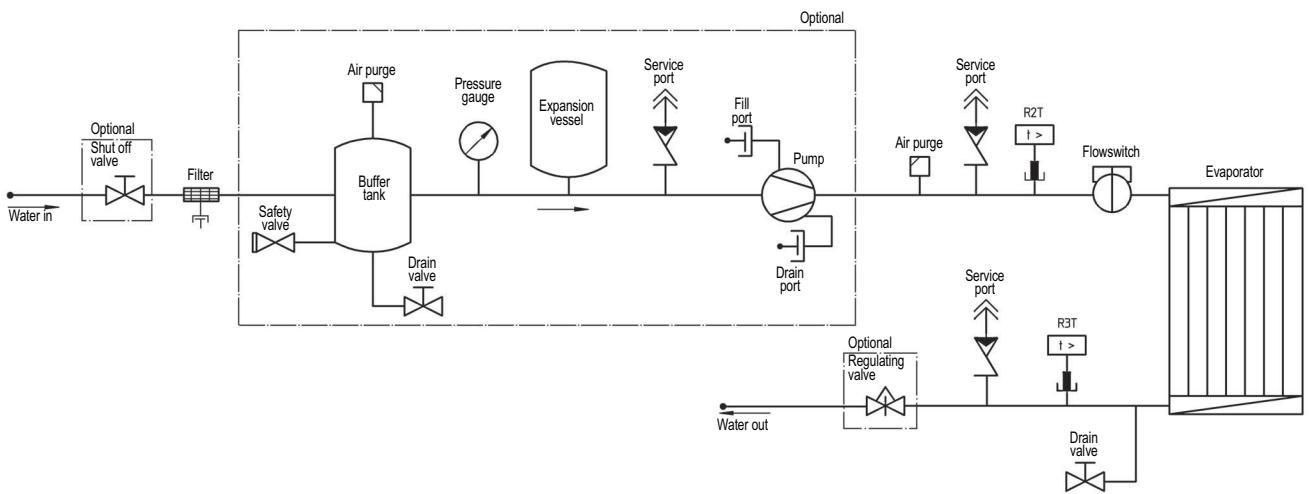

- ↔ : Check valve
- ↔ : Flare Conn.
- ⌋ : Screw conn.

- ⌋ : Flange conn.
- × : Pinched pipe
- : Spinned pipe

3TW57575-2A

1  
6



# 6 Piping diagrams

## 6 - 1 Piping Diagrams

EWAQ080-100DAYN(N-P-B) (piping diagram)

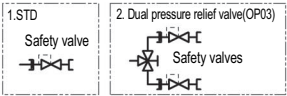
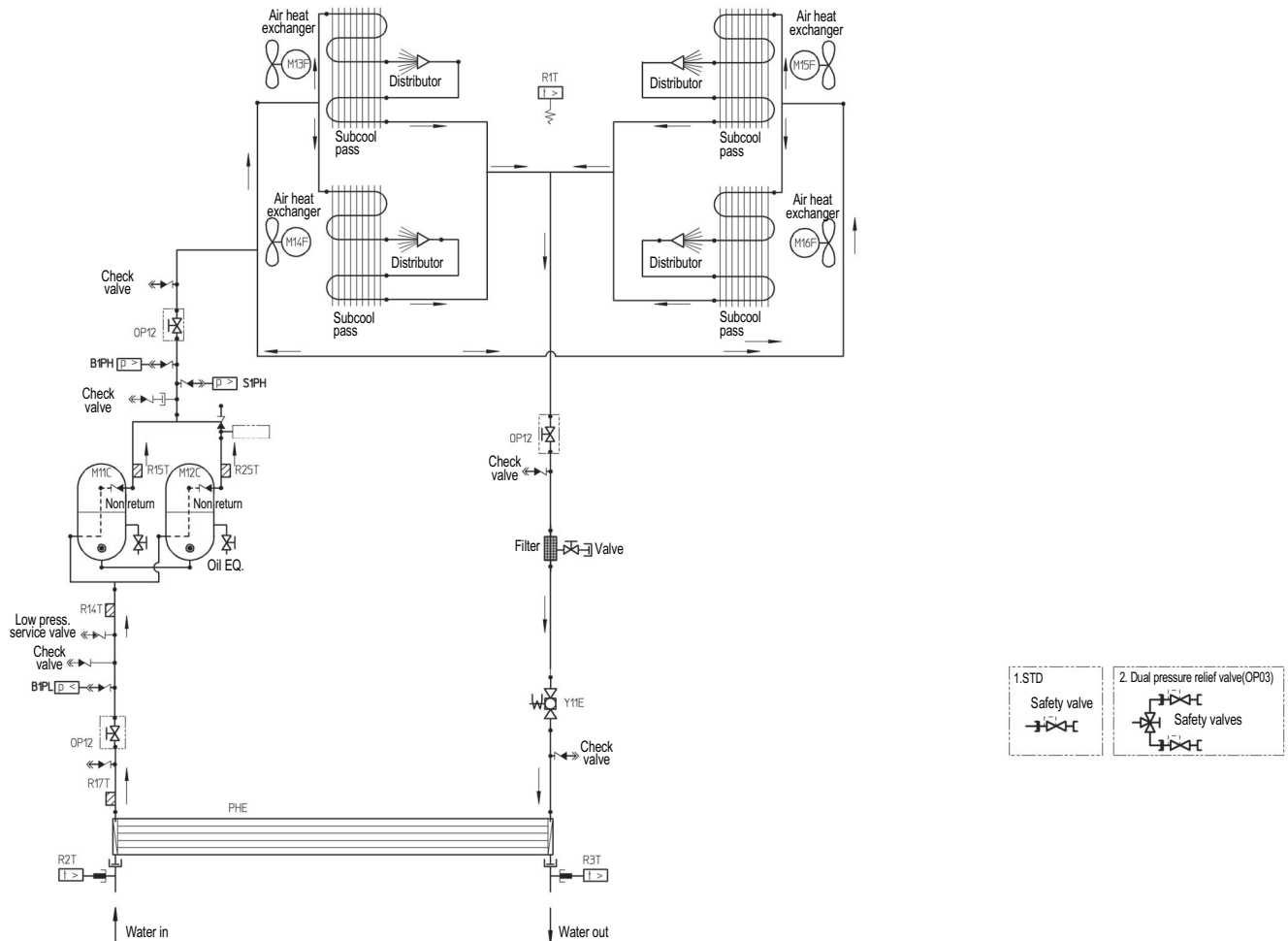

BRAND	DESIGNATION		
M11-12C	Compressor motors	B1PH	High pressure sensor
M13-16F	Fan motors	B1PL	Low pressure sensor
R14T	Suction temperature sensor	Y11E	Electronic expansion valve cooling
R17T	Refrigerant piping temperature sensor	R1T	Ambient temperature sensor
S1PH	High pressure switch	R2T	Evaporator inlet water temperature sensor
R15T, R25T	Discharge temperature sensor	R3T	Evaporator outlet water temperature sensor

- ↔ : Check valve
- ↔ : Flare Conn.
- ↔ : Screw conn.
- ⊥ : Flange conn.
- × : Pinched pipe
- : Spinned pipe

3TW57575-1

# 6 Piping diagrams

## 6 - 1 Piping Diagrams

EWAQ130-210DAYN(N-P-B)(piping diagram)

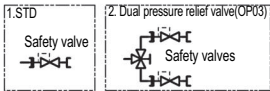
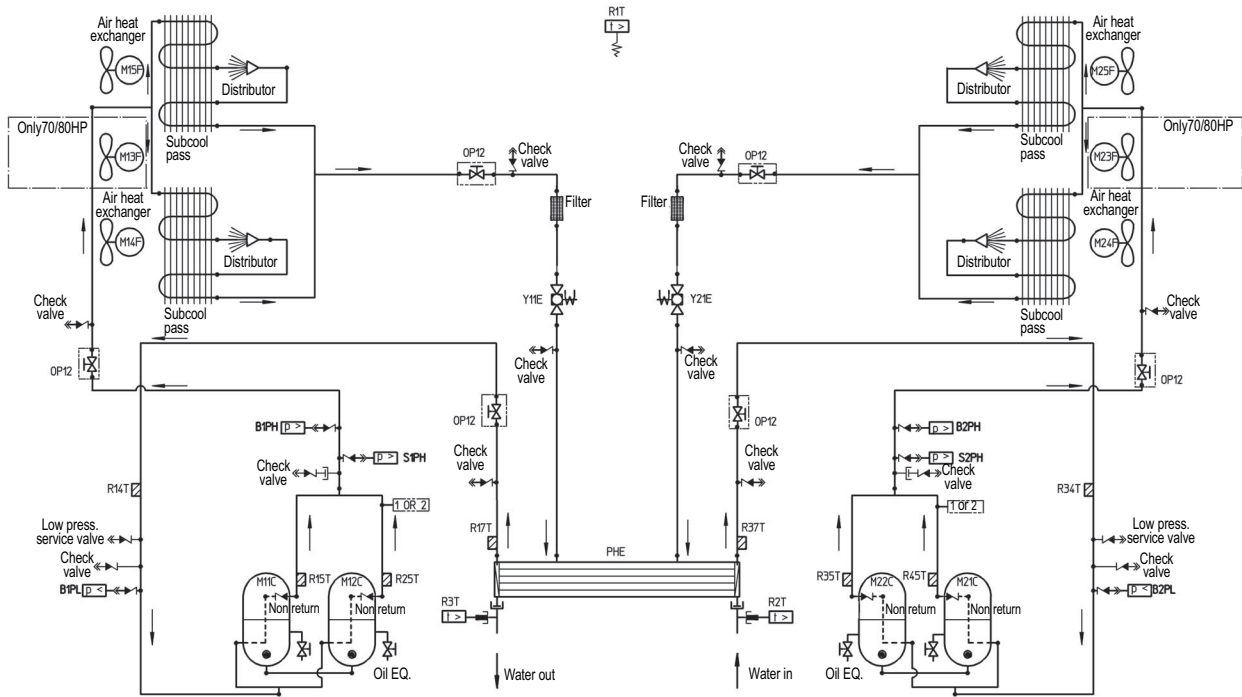

BRAND	DESIGNATION	M23-25F	Fan motors circuit 2
M11-12C	Compressor motors circuit 1	R34T	Suction temperature sensor circuit 2
M13-15F	Fan motors circuit 1	R37T	Refrigerant piping temperature sensor circuit 2
R14T	Suction temperature sensor circuit 1	S2PH	High pressure switch circuit 2
R17T	Refrigerant piping temperature sensor circuit 1	R35T, R35T	Discharge temperature sensor circuit 2
S1PH	High pressure switch circuit 1	B2PH	High pressure sensor circuit 2
R15T, R25T	Discharge temperature sensor circuit 1	B2PL	Low pressure sensor circuit 2
B1PH	High pressure sensor circuit 1	Y21E	Electronic expansion valve cooling circuit 2
B1PL	Low pressure sensor circuit 1	R1T	Ambient temperature sensor
Y11E	Electronic expansion valve cooling circuit 1	R2T	Evaporator inlet water temperature sensor
M21-22C	Compressor motors circuit 2	R3T	Evaporator outlet water temperature sensor

- ↔ : Check valve
- ↔ : Flare Conn.
- |— : Screw conn.
- |— : Flange conn.
- × : Pinched pipe
- : Spinned pipe

2TW57595-1

# 6 Piping diagrams

## 6 - 1 Piping Diagrams

EWAQ240-260DAYN(N-P-B)(piping diagram)

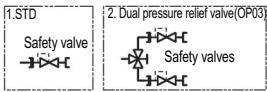
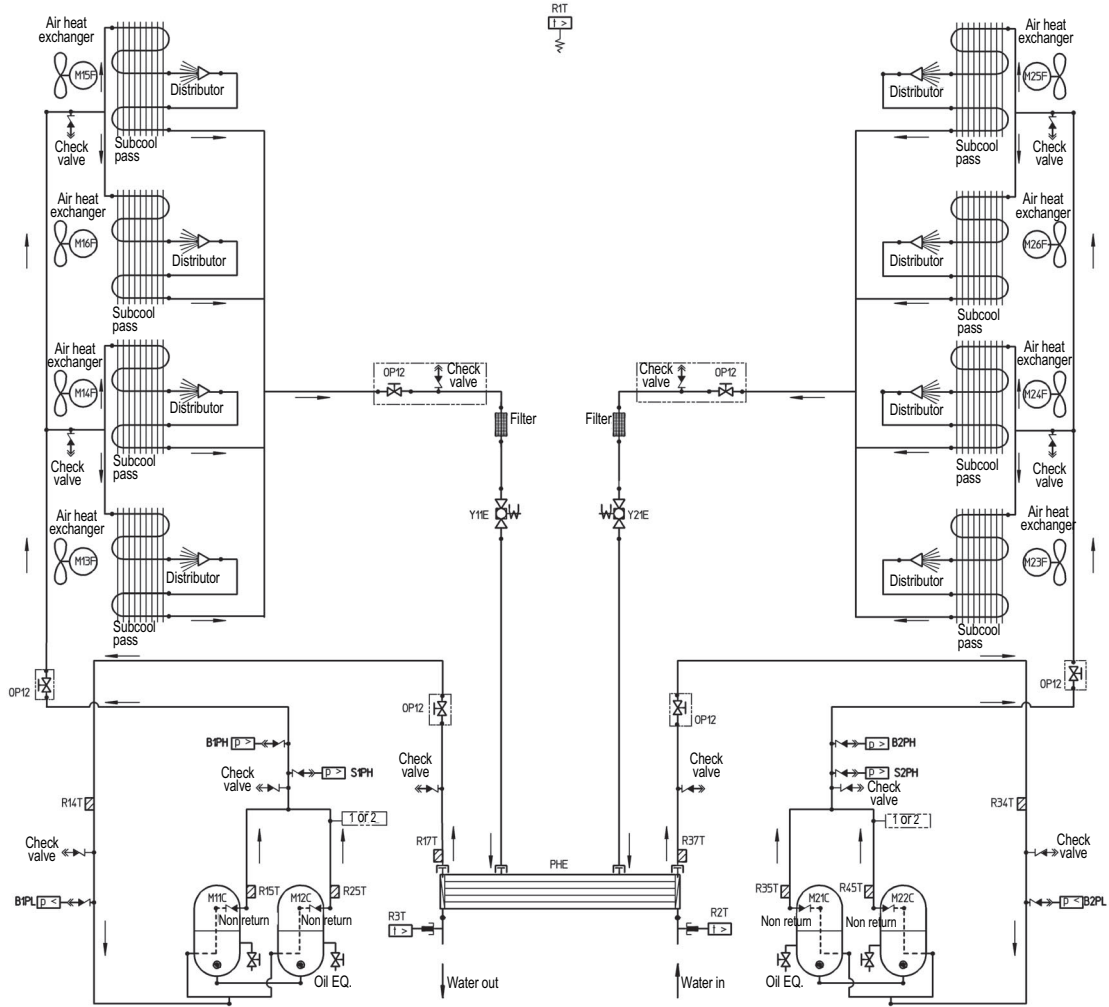

BRAND	DESIGNATION	M23-26F	Fan motors circuit 2
M11-12C	Compressor motors circuit 1	R34T	Suction temperature sensor circuit 2
M13-16F	Fan motors circuit 1	R37T	Refrigerant piping temperature sensor circuit 2
R14T	Suction temperature sensor circuit 1	S2PH	High pressure switch circuit 2
R17T	Refrigerant piping temperature sensor circuit 1	R35T, R35T	Discharge temperature sensor circuit 2
S1PH	High pressure switch circuit 1	B2PH	High pressure sensor circuit 2
R15T, R25T	Discharge temperature sensor circuit 1	B2PL	Low pressure sensor circuit 2
B1PH	High pressure sensor circuit 1	Y21E	Electronic expansion valve cooling circuit 2
B1PL	Low pressure sensor circuit 1	R1T	Ambient temperature sensor
Y11E	Electronic expansion valve cooling circuit 1	R2T	Evaporator inlet water temperature sensor
M21-22C	Compressor motors circuit 2	R3T	Evaporator outlet water temperature sensor



2TW57635-1

# 7 External connection diagrams

## 7 - 1 External Connection Diagrams

0	1	2	3	4	5	6	7	8	9																																								
<b>LEGEND</b>					<p>(1) Fieldwiring: Main power connection</p>																																												
<p>Translation of this legend can be found in the installation manual.</p> <table border="1" style="width:100%; border-collapse: collapse;"> <tr> <td colspan="2" style="text-align: center;">Not included with standard unit</td> <td colspan="2"></td> </tr> <tr> <td style="text-align: center;">Obligatory</td> <td style="text-align: center;">#</td> <td style="text-align: center;">Not possible as option</td> <td style="text-align: center;">##</td> </tr> <tr> <td style="text-align: center;">Not obligatory</td> <td style="text-align: center;">*</td> <td style="text-align: center;">Possible as option</td> <td style="text-align: center;">**</td> </tr> </table>										Not included with standard unit				Obligatory	#	Not possible as option	##	Not obligatory	*	Possible as option	**																												
Not included with standard unit																																																	
Obligatory	#	Not possible as option	##																																														
Not obligatory	*	Possible as option	**																																														
<table border="1" style="width:100%; border-collapse: collapse;"> <tr> <th>Part number</th> <th>Description</th> </tr> <tr> <td>A02P</td> <td>** Communication PCB (EKACPG)</td> </tr> <tr> <td>A4P</td> <td>** PCB wired remote control</td> </tr> <tr> <td>A5P</td> <td>** PCB wired remote control (EKRUFG)</td> </tr> <tr> <td>E5H</td> <td>* fieldheater</td> </tr> <tr> <td>F1, F2, F3</td> <td># main fuses</td> </tr> <tr> <td>F4, F5</td> <td># fuses for heaters</td> </tr> <tr> <td>H11, H2, H2P</td> <td>* indication lamp: operation compressor</td> </tr> <tr> <td>H1P</td> <td>* indication lamp: alarm signal (default NO)</td> </tr> <tr> <td>H2, H3, H5, H6P</td> <td>* indication lamp for changeable digital outputs</td> </tr> <tr> <td>K1P</td> <td># pump contactor (Only OPSP/OPHP/OPSC/OPTP/OPTC)</td> </tr> <tr> <td>K2P</td> <td># pump contactor (Only for OPTP/OPTC)</td> </tr> <tr> <td>K1S</td> <td>* overcurrent relay pump (P/B unit or OPSC)</td> </tr> <tr> <td>M1P</td> <td>* pump motor 1 (Only OPSP/OPHP/OPSC/OPTP/OPTC)</td> </tr> <tr> <td>M2P</td> <td>* pump motor 2 (Only for OPTP/OPTC)</td> </tr> <tr> <td>R8T</td> <td>* temperature sensor for changeable analog input</td> </tr> <tr> <td>S1M</td> <td>main isolator switch</td> </tr> <tr> <td>S1, 2, 3, 4, 5S</td> <td>* switch for changeable digital input</td> </tr> <tr> <td>S2M</td> <td># heater tape isolator switch</td> </tr> <tr> <td>V2C</td> <td>** ferrite core (EKACPG)</td> </tr> </table>					Part number	Description	A02P	** Communication PCB (EKACPG)	A4P	** PCB wired remote control	A5P	** PCB wired remote control (EKRUFG)	E5H	* fieldheater	F1, F2, F3	# main fuses	F4, F5	# fuses for heaters	H11, H2, H2P	* indication lamp: operation compressor	H1P	* indication lamp: alarm signal (default NO)	H2, H3, H5, H6P	* indication lamp for changeable digital outputs	K1P	# pump contactor (Only OPSP/OPHP/OPSC/OPTP/OPTC)	K2P	# pump contactor (Only for OPTP/OPTC)	K1S	* overcurrent relay pump (P/B unit or OPSC)	M1P	* pump motor 1 (Only OPSP/OPHP/OPSC/OPTP/OPTC)	M2P	* pump motor 2 (Only for OPTP/OPTC)	R8T	* temperature sensor for changeable analog input	S1M	main isolator switch	S1, 2, 3, 4, 5S	* switch for changeable digital input	S2M	# heater tape isolator switch	V2C	** ferrite core (EKACPG)	<p>(1) Fieldwiring: communication wiring</p>				
Part number	Description																																																
A02P	** Communication PCB (EKACPG)																																																
A4P	** PCB wired remote control																																																
A5P	** PCB wired remote control (EKRUFG)																																																
E5H	* fieldheater																																																
F1, F2, F3	# main fuses																																																
F4, F5	# fuses for heaters																																																
H11, H2, H2P	* indication lamp: operation compressor																																																
H1P	* indication lamp: alarm signal (default NO)																																																
H2, H3, H5, H6P	* indication lamp for changeable digital outputs																																																
K1P	# pump contactor (Only OPSP/OPHP/OPSC/OPTP/OPTC)																																																
K2P	# pump contactor (Only for OPTP/OPTC)																																																
K1S	* overcurrent relay pump (P/B unit or OPSC)																																																
M1P	* pump motor 1 (Only OPSP/OPHP/OPSC/OPTP/OPTC)																																																
M2P	* pump motor 2 (Only for OPTP/OPTC)																																																
R8T	* temperature sensor for changeable analog input																																																
S1M	main isolator switch																																																
S1, 2, 3, 4, 5S	* switch for changeable digital input																																																
S2M	# heater tape isolator switch																																																
V2C	** ferrite core (EKACPG)																																																
<b>Changeable I/O possible functions</b>					<p>Unit name</p> <p style="text-align: right;">EWAQ/EWYQ 80-260</p>																																												
<p>Refer to the installation manual for instructions how to configure changeable I/O</p> <table border="1" style="width:100%; border-collapse: collapse;"> <tr> <th>Changeable digital input (4 available)</th> <th>Changeable analog output (1 available)</th> </tr> <tr> <td> <ul style="list-style-type: none"> <li>-None</li> <li>-Status</li> <li>-Dual setpoint</li> <li>-Remote on-off</li> <li>-Capacity limitation 25%, 50%, 75% or setting</li> <li>-Low noise (only for OP1P)</li> <li>-Free cooling signal</li> <li>-Fan forced on</li> </ul> </td> <td> <ul style="list-style-type: none"> <li>-None</li> <li>-Unit Capacity (mA, V)</li> <li>-Details of types</li> <li>  Type mA: 0, 20mA/4, 20mA</li> <li>  Type V: 0-1V/0-5V/0-10V</li> </ul> </td> </tr> </table>										Changeable digital input (4 available)	Changeable analog output (1 available)	<ul style="list-style-type: none"> <li>-None</li> <li>-Status</li> <li>-Dual setpoint</li> <li>-Remote on-off</li> <li>-Capacity limitation 25%, 50%, 75% or setting</li> <li>-Low noise (only for OP1P)</li> <li>-Free cooling signal</li> <li>-Fan forced on</li> </ul>	<ul style="list-style-type: none"> <li>-None</li> <li>-Unit Capacity (mA, V)</li> <li>-Details of types</li> <li>  Type mA: 0, 20mA/4, 20mA</li> <li>  Type V: 0-1V/0-5V/0-10V</li> </ul>	<table border="1" style="width:100%; border-collapse: collapse;"> <tr> <th>Changeable digital output (6 or 5 available depending on unit)</th> <th>Changeable analog input (4 available)</th> </tr> <tr> <td> <ul style="list-style-type: none"> <li>-None</li> <li>-Closest</li> <li>-2nd pump</li> <li>-100% capacity</li> <li>-Full capacity</li> <li>-Free cooling</li> <li>-General operation</li> <li>-Safety warning NO</li> <li>-Safety warning NC (only for Ch.DO1)</li> <li>-Safety NO (excluding warning)</li> <li>-Safety NC (excluding warning) (only for Ch.DO1)</li> <li>-C1, C2 Safety NO</li> <li>-Warning NO</li> <li>-C1, C2 operation</li> <li>-Cooling (only EWYQ)</li> <li>-Heating (only EWYQ)</li> <li>-Defrost (only EWYQ)</li> </ul> </td> <td> <ul style="list-style-type: none"> <li>-None</li> <li>-Status (mA, V, NTC, DI)</li> <li>-Floating setpoint (mA, V, NTC*)</li> <li>-Water temperature measurement (NTC*)</li> <li>-Changeable DI, refer to Ch DI for possibilities (DI)</li> <li>-Details of types:</li> <li>  Type mA: 0, 20mA/4, 20mA (internal 5V or external power supply)</li> <li>  Type V: 0-1V/0-5V/0-10V</li> <li>  Type DI: DI (5V detection)</li> </ul> </td> </tr> </table> <p>* for allowed NTC types and how to configure the software please contact your local dealer.</p>					Changeable digital output (6 or 5 available depending on unit)	Changeable analog input (4 available)	<ul style="list-style-type: none"> <li>-None</li> <li>-Closest</li> <li>-2nd pump</li> <li>-100% capacity</li> <li>-Full capacity</li> <li>-Free cooling</li> <li>-General operation</li> <li>-Safety warning NO</li> <li>-Safety warning NC (only for Ch.DO1)</li> <li>-Safety NO (excluding warning)</li> <li>-Safety NC (excluding warning) (only for Ch.DO1)</li> <li>-C1, C2 Safety NO</li> <li>-Warning NO</li> <li>-C1, C2 operation</li> <li>-Cooling (only EWYQ)</li> <li>-Heating (only EWYQ)</li> <li>-Defrost (only EWYQ)</li> </ul>	<ul style="list-style-type: none"> <li>-None</li> <li>-Status (mA, V, NTC, DI)</li> <li>-Floating setpoint (mA, V, NTC*)</li> <li>-Water temperature measurement (NTC*)</li> <li>-Changeable DI, refer to Ch DI for possibilities (DI)</li> <li>-Details of types:</li> <li>  Type mA: 0, 20mA/4, 20mA (internal 5V or external power supply)</li> <li>  Type V: 0-1V/0-5V/0-10V</li> <li>  Type DI: DI (5V detection)</li> </ul>																											
Changeable digital input (4 available)	Changeable analog output (1 available)																																																
<ul style="list-style-type: none"> <li>-None</li> <li>-Status</li> <li>-Dual setpoint</li> <li>-Remote on-off</li> <li>-Capacity limitation 25%, 50%, 75% or setting</li> <li>-Low noise (only for OP1P)</li> <li>-Free cooling signal</li> <li>-Fan forced on</li> </ul>	<ul style="list-style-type: none"> <li>-None</li> <li>-Unit Capacity (mA, V)</li> <li>-Details of types</li> <li>  Type mA: 0, 20mA/4, 20mA</li> <li>  Type V: 0-1V/0-5V/0-10V</li> </ul>																																																
Changeable digital output (6 or 5 available depending on unit)	Changeable analog input (4 available)																																																
<ul style="list-style-type: none"> <li>-None</li> <li>-Closest</li> <li>-2nd pump</li> <li>-100% capacity</li> <li>-Full capacity</li> <li>-Free cooling</li> <li>-General operation</li> <li>-Safety warning NO</li> <li>-Safety warning NC (only for Ch.DO1)</li> <li>-Safety NO (excluding warning)</li> <li>-Safety NC (excluding warning) (only for Ch.DO1)</li> <li>-C1, C2 Safety NO</li> <li>-Warning NO</li> <li>-C1, C2 operation</li> <li>-Cooling (only EWYQ)</li> <li>-Heating (only EWYQ)</li> <li>-Defrost (only EWYQ)</li> </ul>	<ul style="list-style-type: none"> <li>-None</li> <li>-Status (mA, V, NTC, DI)</li> <li>-Floating setpoint (mA, V, NTC*)</li> <li>-Water temperature measurement (NTC*)</li> <li>-Changeable DI, refer to Ch DI for possibilities (DI)</li> <li>-Details of types:</li> <li>  Type mA: 0, 20mA/4, 20mA (internal 5V or external power supply)</li> <li>  Type V: 0-1V/0-5V/0-10V</li> <li>  Type DI: DI (5V detection)</li> </ul>																																																
<p>DAIKIN</p> <p style="text-align: center;">Description</p> <p style="text-align: center;">Connection diagram</p>					<p style="text-align: right;">Drawing number</p> <p style="text-align: right;">Revision</p> <p style="text-align: right;">Page</p> <p style="text-align: right;">4TW57579-2</p> <p style="text-align: right;">B</p> <p style="text-align: right;">1</p>																																												

0	1	2	3	4	5	6	7	8	9
<p>(3) Fieldwiring: Digital input terminals</p> <p>OBLIGATORY FOR MODELS WITHOUT OPSC/OPTC/OPSP/OPTP/OPHP</p>					<p>(4) Fieldwiring: Analog input terminals (connection is depending on type setting: NTC or mA or V or DI)</p>				
<p>(5) Fieldwiring: Analog output terminals (types: mA or V)</p>					<p>(6) Fieldwiring: Output terminals</p>				
<p>Unit name</p> <p style="text-align: right;">EWAQ/EWYQ 80-260</p>					<p style="text-align: right;">Drawing number</p> <p style="text-align: right;">Revision</p> <p style="text-align: right;">Page</p> <p style="text-align: right;">4TW57579-2</p> <p style="text-align: right;">B</p> <p style="text-align: right;">2</p>				

## 8 Sound data

### 8 - 1 Sound Power Spectrum

#### EWAQ-EWYQ-DAYN(N-P-B)

STD - Units LWE= 7°C / Tamb = 35°C	Sound power Lw per Octave band (dBA)								Total (dBA)
	63	125	250	500	1000	2000	4000	8000	LwA
EW(A/Y)Q080DAYN*	64	69	72	82	81	77	71	62	86
EW(A/Y)Q100DAYN*	62	66	71	79	82	80	74	64	86
EW(A/Y)Q130DAYN*	64	70	73	81	85	80	72	61	88
EW(A/Y)Q150DAYN*	65	74	75	85	84	80	74	65	89
EW(A/Y)Q180DAYN*	70	75	79	85	86	82	75	64	90
EW(A/Y)Q210DAYN*	67	74	79	85	86	83	76	64	90
EW(A/Y)Q(230/240)DAYN*	71	72	77	87	86	83	77	67	91
EW(A/Y)Q(250/260)DAYN*	71	72	77	87	86	83	77	67	91

OPLN - Units LWE= 7°C / Tamb = 35°C	Sound power Lw per Octave band (dBA)								Total (dBA)
	63	125	250	500	1000	2000	4000	8000	LwA
EW(A/Y)Q080DAYN*	62	67	70	80	79	75	69	60	84
EW(A/Y)Q100DAYN*	60	64	69	77	80	78	72	62	84
EW(A/Y)Q130DAYN*	61	67	70	78	82	77	69	58	85
EW(A/Y)Q150DAYN*	62	71	72	82	81	77	71	62	86
EW(A/Y)Q180DAYN*	68	73	77	83	84	80	73	62	88
EW(A/Y)Q210DAYN*	65	72	77	83	84	81	74	62	88
EW(A/Y)Q(230/240)DAYN*	68	69	74	84	83	80	74	64	88
EW(A/Y)Q(250/260)DAYN*	68	69	74	84	83	80	74	64	88

OPLN - Units LWE= 7°C / Tamb = 25°C	Sound power Lw per Octave band (dBA)								Total (dBA)
	63	125	250	500	1000	2000	4000	8000	LwA
EW(A/Y)Q080DAYN*	61	66	69	79	78	74	68	59	83
EW(A/Y)Q100DAYN*	59	63	68	76	79	77	71	61	83
EW(A/Y)Q130DAYN*	60	66	69	77	81	76	68	57	84
EW(A/Y)Q150DAYN*	60	69	70	80	79	75	69	90	84
EW(A/Y)Q180DAYN*	66	71	75	81	82	79	72	60	86
EW(A/Y)Q210DAYN*	63	70	75	81	82	79	72	60	86
EW(A/Y)Q(230/240)DAYN*	67	68	73	83	82	79	73	63	87
EW(A/Y)Q(250/260)DAYN*	67	68	73	83	82	79	73	63	87

#### NOTES

- 1 Values of Sound power according to ISO9614-2
- 2 LWE= Leaving Water Evaporator temperature (°C)  
Tamb= Ambient temperature

4TW57577-1C

# 9 Installation

## 9 - 1 Fixation and Foundation of Units

EWAQ-EWYQ080-150DAYN(N-P-B)

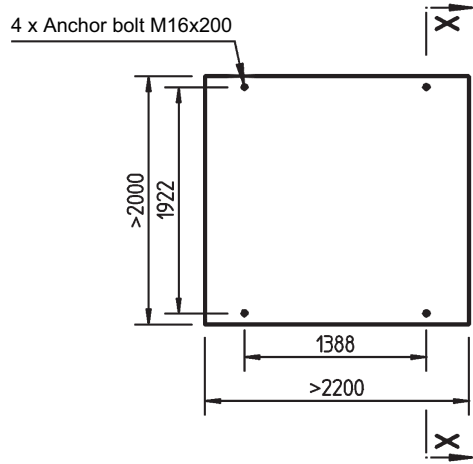

Fix anchor bolts into the concrete foundation. The concrete foundation should be higher than the floor level by approximately 100 mm for ease of plumbing work and better drain. Further, strength of the floor should be sufficient to support the weights of concrete foundation and unit. Be certain that foundation surface is even and flat.

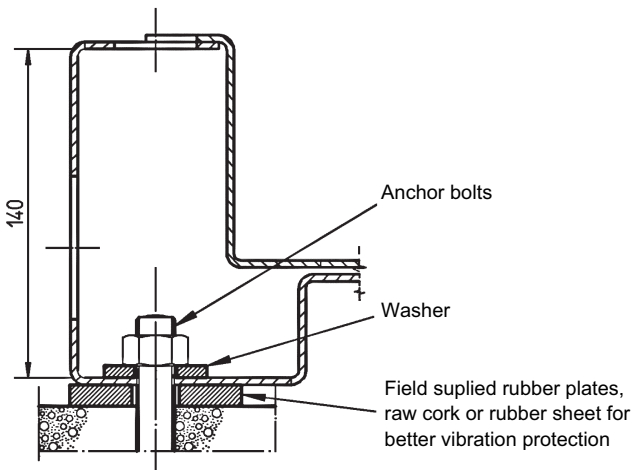
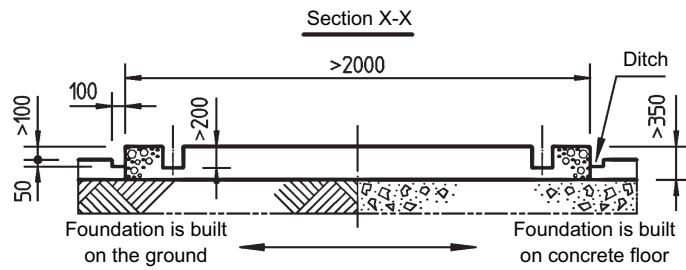

### NOTES

- 1 The measurement tabulated is based on the fact the base is made in the ground or on a concrete floor. In case the base is made on a concrete floor. In case the base is made on a rigid concrete floor, it is possible to include thickness of concrete floor, in that of the base.
- 2 In case a base is made on concrete floor, be sure to provide a ditch as shown. It is important to extract drainage regardless of whether a base is made in the ground or on the concrete floor. (Ditch → Sewerage).
- 3 Ingredient ratio of the concrete is cement: 1, sand: 2, gravel: 3, which is standard and insert iron bars of  $\varnothing 10$  at every interval of 300mm. The edge of the concrete base should be planed.

4TW57599-1

## 9 Installation

### 9 - 1 Fixation and Foundation of Units

EWAQ-EWYQ180-210DAYN(N-P-B)

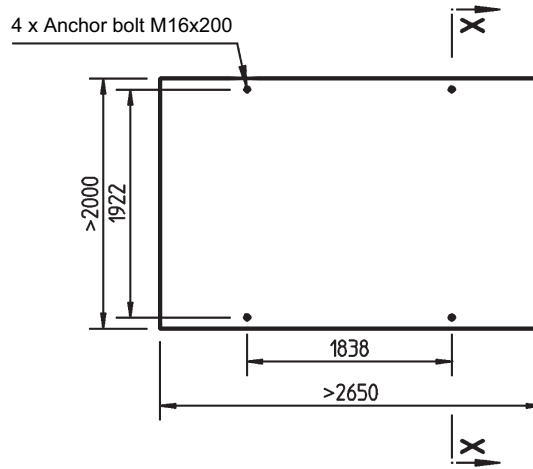

Fix anchor bolts into the concrete foundation. The concrete foundation should be higher than the floor level by approximately 100 mm for ease of plumbing work and better drain. Further, strength of the floor should be sufficient to support the weights of concrete foundation and unit. Be certain that foundation surface is even and flat.

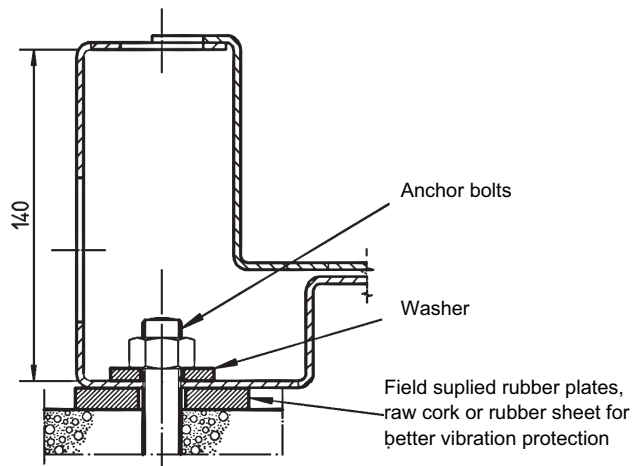
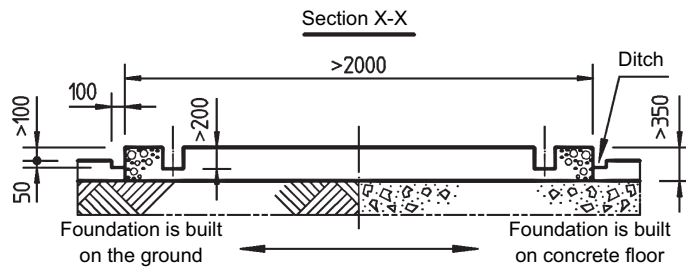

#### NOTES

- 1 The measurement tabulated is based on the fact the base is made in the ground or on a concrete floor. In case the base is made on a rigid concrete floor, it is possible to include thickness of concrete floor, in that of the base.
- 2 In case a base is made on concrete floor, be sure to provide a ditch as shown. It is important to extract drainage regardless of whether a base is made in the ground or on the concrete floor. (Ditch → Sewerage).
- 3 Ingredient ratio of the concrete is cement: 1, sand: 2, gravel: 3, which is standard and insert iron bars of  $\varnothing 10$  at every interval of 300mm. The edge of the concrete base should be planed.

4TW57619-1

## 9 Installation

### 9 - 1 Fixation and Foundation of Units

EWAQ240-260DAYN(N-P-B)\_EWYQ230-250DAYN(N-P-B)

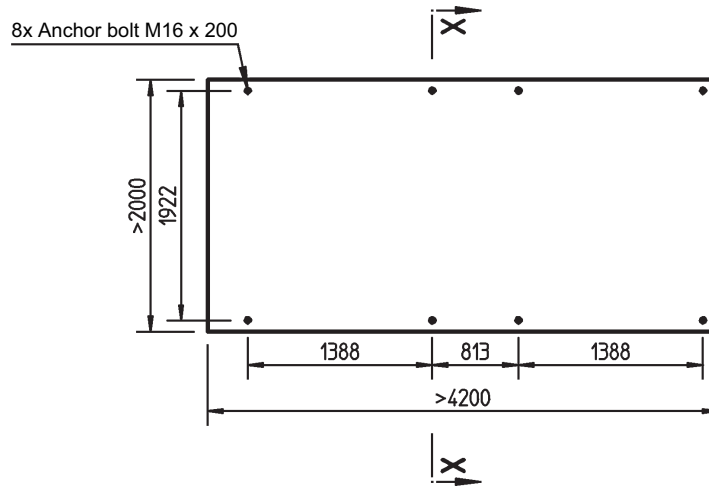

Fix anchor bolts into the concrete foundation. The concrete foundation should be higher than the floor level by approximately 100 mm for ease of plumbing work and better drain. Further, strength of the floor should be sufficient to support the weights of concrete foundation and unit. Be certain that foundation surface is even and flat.

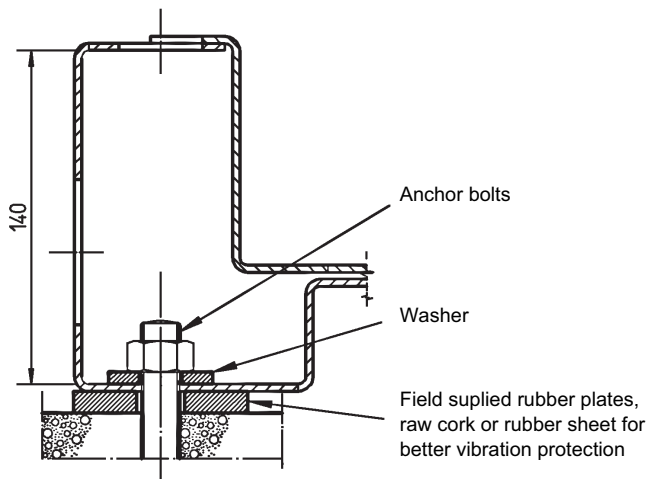
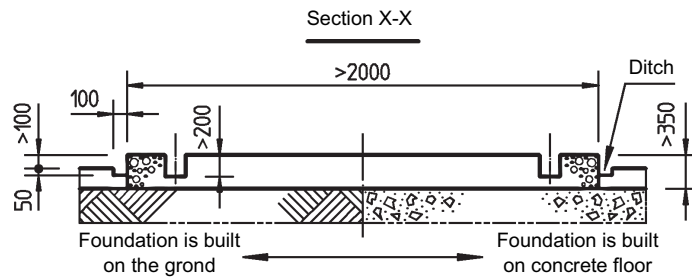

#### NOTES

- 1 The measurement tabulated is based on the fact the base is made in the ground or on a concrete floor. In case the base is made on a rigid concrete floor, it is possible to include thickness of concrete floor in that of the base.
- 2 In case a base is made on concrete floor, be sure to provide a ditch as shown. It is important to extract drainage regardless of whether a base is made in the ground or on the concrete floor. (Ditch → Sewerage).
- 3 Ingredient ratio of the concrete is cement: 1, sand:2, gravel:3, which is standard and insert iron bars of  $\varnothing 10$  at every interval of 300mm. The edge of the concrete base should be planed.

4TW57639-1



# 9 Installation

## 9 - 2 Water Charge, Flow and Quality

ITEMS (1) (5)	Cooling water (3)		Cooled water		Heated water (2)		Tendency if out of criteria
	Circulating system		Circulating water [Below 20°C]	Supply water (4)	High temperature		
	Circulating water	Supply water (4)			Circulating water [60°C ~ 80°C]	Supply water (4)	
pH	6.5~8.2	6.0~8.0	6.8~8.0	6.8~8.0	7.0~8.0	7.0~8.0	Corrosion + scale
Electrical conductivity	Below 80	Below 30	Below 40	Below 30	Below 30	Below 30	Corrosion + scale
Items to be controlled:	(µS/cm) at 25°C (1)	(Below 800)	(Below 400)	(Below 300)	(Below 300)	(Below 300)	Corrosion + scale
	Chloride ion	Below 200	Below 50	Below 50	Below 50	Below 30	Corrosion
	Sulfate ion	Below 200	Below 50	Below 50	Below 50	Below 30	Corrosion
	M-alkalinity (pH4.8)	Below 100	Below 50	Below 50	Below 50	Below 50	Scale
	Total hardness	Below 200	Below 70	Below 70	Below 70	Below 70	Scale
	Calcium hardness	Below 150	Below 50	Below 50	Below 50	Below 50	Scale
	Silica ion	Below 50	Below 30	Below 30	Below 30	Below 30	Scale
	Iron	Below 1.0	Below 0.3	Below 1.0	Below 0.3	Below 1.0	Corrosion + scale
	Copper	Below 0.3	Below 0.1	Below 1.0	Below 0.1	Below 0.1	Corrosion
	Sulfite ion	Not detectable	Not detectable	Not detectable	Not detectable	Not detectable	Corrosion
	Ammonium ion	Below 1.0	Below 0.1	Below 1.0	Below 0.1	Below 0.1	Corrosion
	Remaining chloride	Below 0.3	Below 0.3	Below 0.3	Below 0.3	Below 0.1	Corrosion
	Free carbide	Below 4.0	Below 4.0	Below 4.0	Below 4.0	Below 4.0	Corrosion
	Stability index	6.0~7.0	---	---	---	---	---

3TW50179-1

- Names, definitions and units are according to JIS K 0101. Units and figures between brackets are old units published as reference only.
- In case of using heated water (more than 40°C), corrosion is generally noticeable. Especially when the iron material is in direct contact with water without any protection shields, it is desirable to give the valid measures for corrosion. e.g. chemical measure.
- In the cooling water using hermetic cooling tower, closed circuit water is according to heated water standard, and scattered water is according to cooling water standard.
- Supply water is considered drink water, industrial water and ground water except for genuine water, neutral water and soft water.
- The above mentioned items are representable items in corrosion and scale cases.

# 10 Operation range

## 10 - 1 Operation Range

EWAQ080-100-180-210-240-260DAYN(N-P-B)

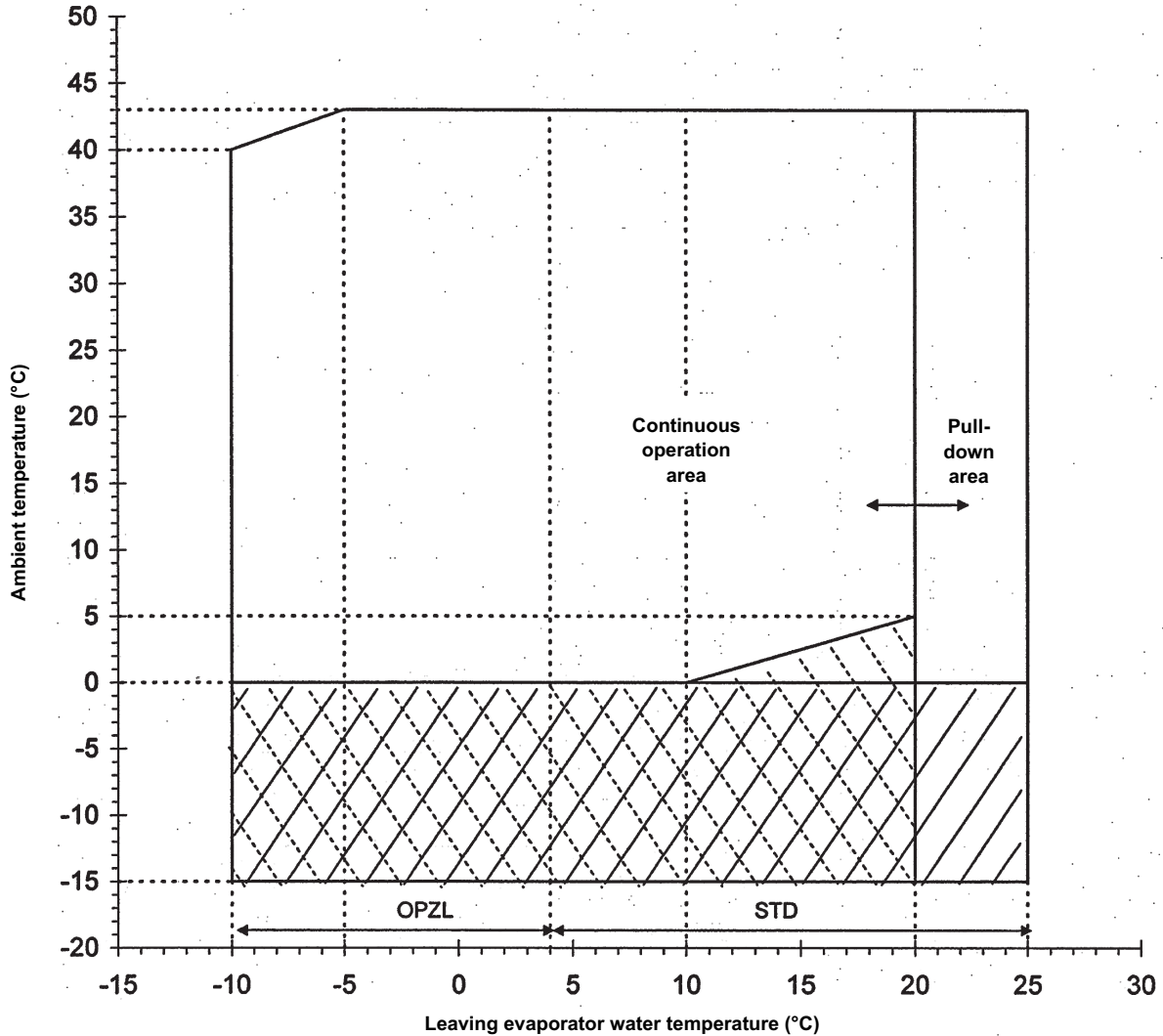

STD: Standard unit

OPZL: Leaving water evaporator from -10 to 4°C by use of glycol



Protect the water circuit against freezing by:

\* OR OP10: heater tape

\* Or filling up the system with a glycol solution



OPIF Option Inverter Fans EWAQ080-100-180-210-240-260

# 10 Operation range

## 10 - 1 Operation Range

EWAQ130-150DAYN(N-P-B)

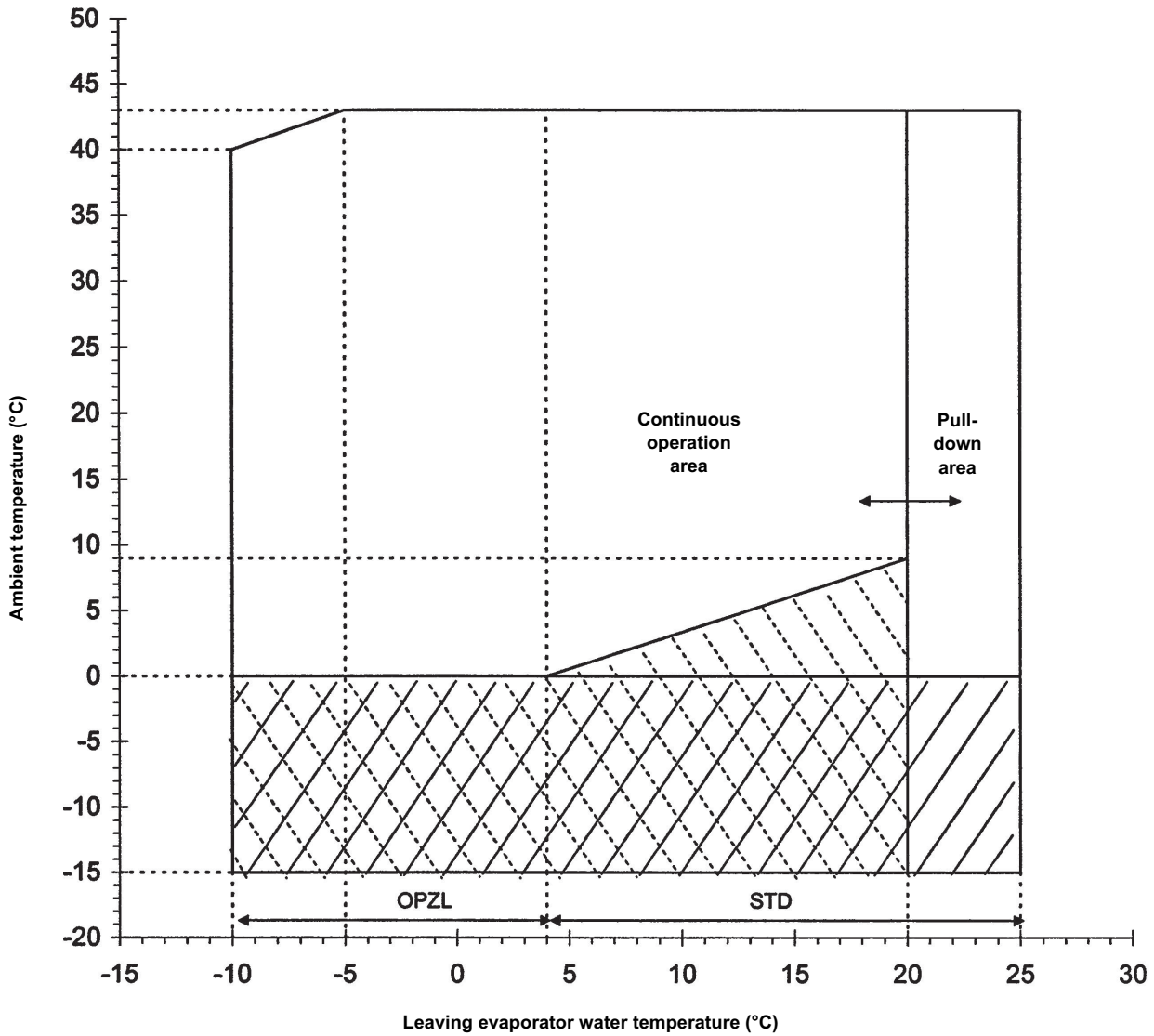

STD: Standard unit

OPZL: Leaving water evaporator from -10 to 4°C by use of glycol



Protect the water circuit against freezing by:

\* OR OP10: heater tape

\* Or filling up the system with a glycol solution



OPIF Option Inverter Fans EWAQ130-150

4TW57603-1A

# 11 Hydraulic performance

## 11 - 1 Water Pressure Drop Curve Evaporator

EWAQ080-100DAYN(N-P-B)

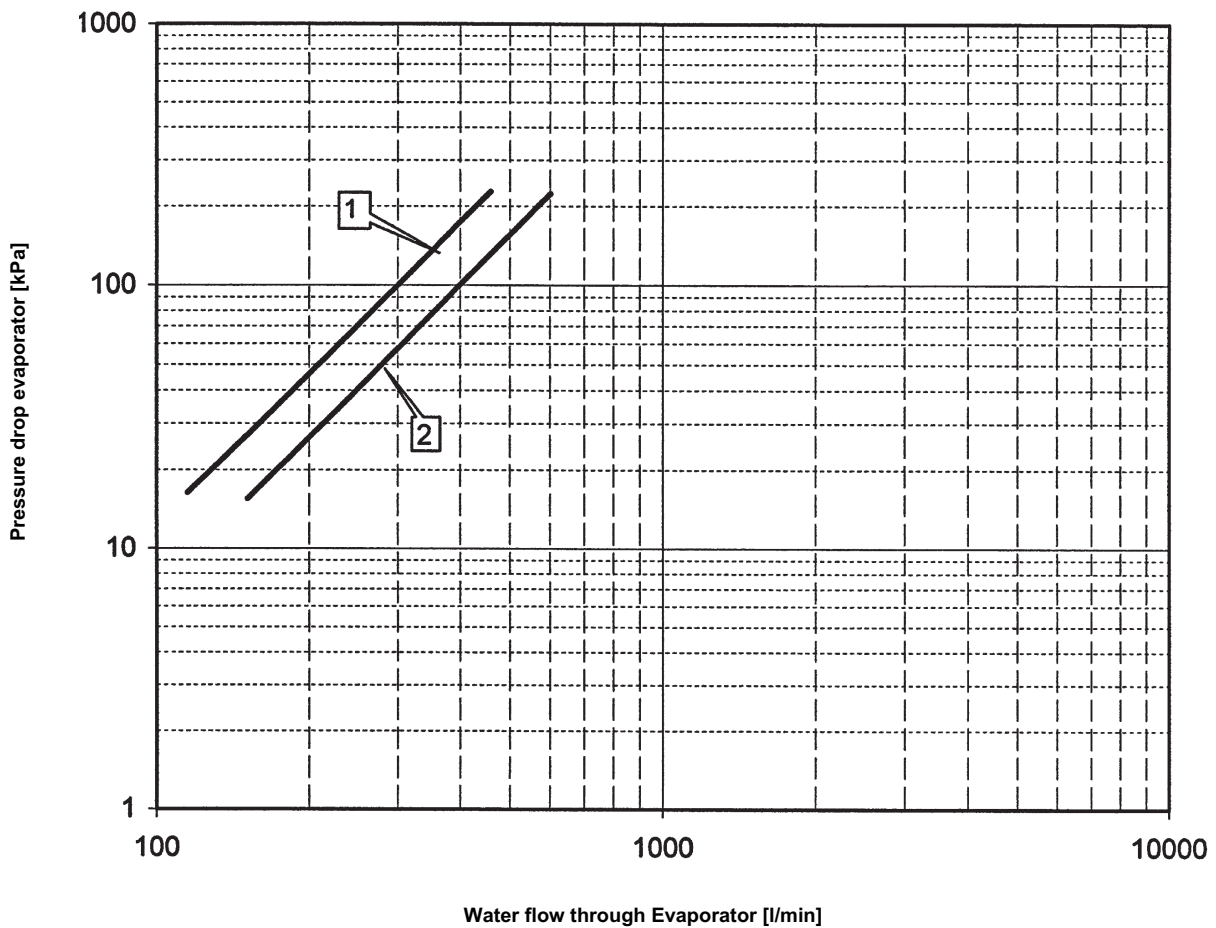

- 1. EWAQ080DAYN\*
- 2. EWAQ100DAYN\*

**Warning:**

Selecting a flow outside the curves can cause damage to or malfunction of the unit. See also minimum and maximum allowed water flowrange in the technical specifications.

# 11 Hydraulic performance

## 11 - 1 Water Pressure Drop Curve Evaporator

EWAQ240-260DAYN(N-P-B)

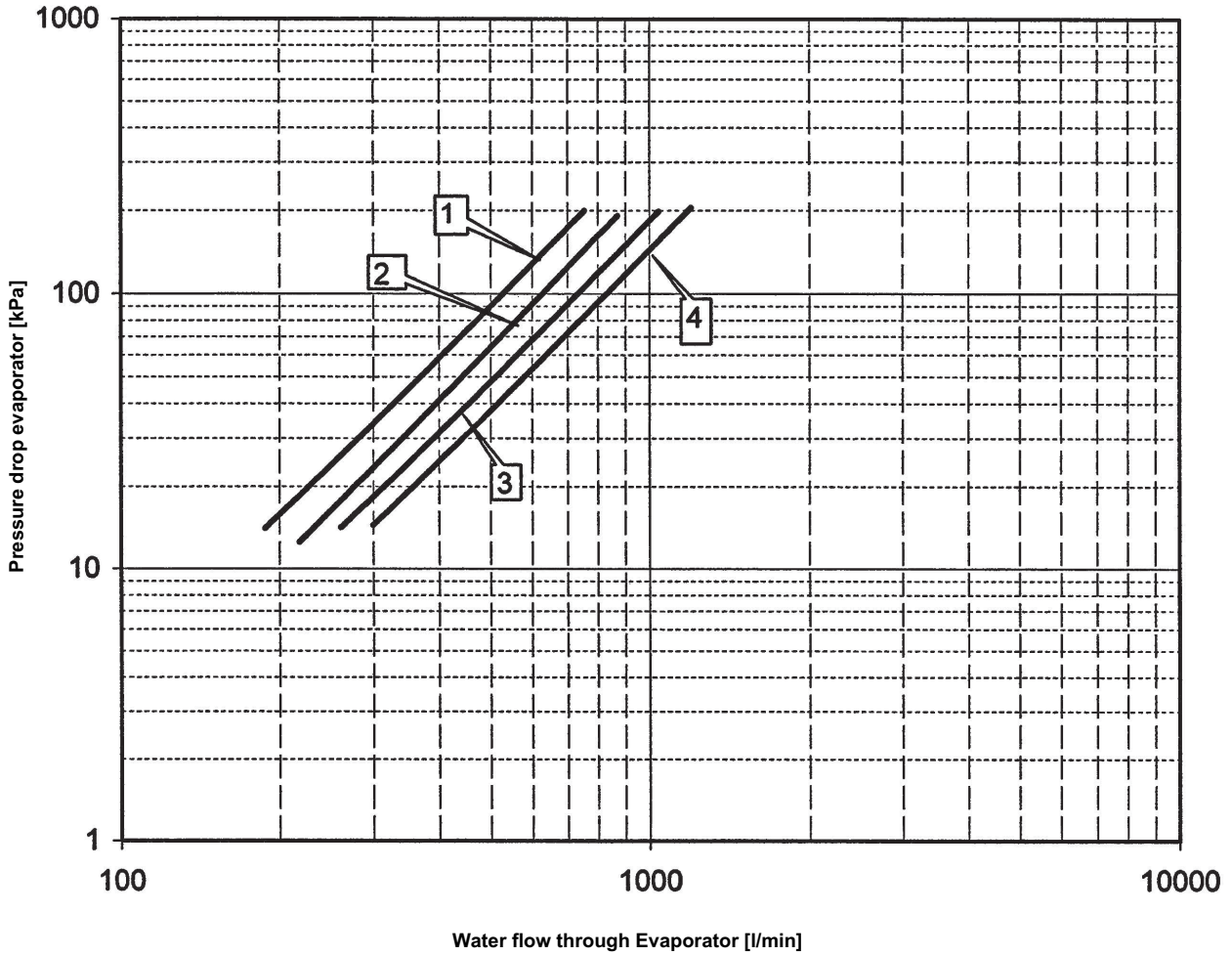

- 1. EWAQ240DAYN\*
- 2. EWAQ260DAYN\*

**Warning:**

Selecting a flow outside the curves can cause damage to or malfunction of the unit. See also minimum and maximum allowed water flowrange in the technical specifications.

4TW57599-5

# 11 Hydraulic performance

## 11 - 1 Water Pressure Drop Curve Evaporator

EWAQ240-260DAYN(N-P-B)

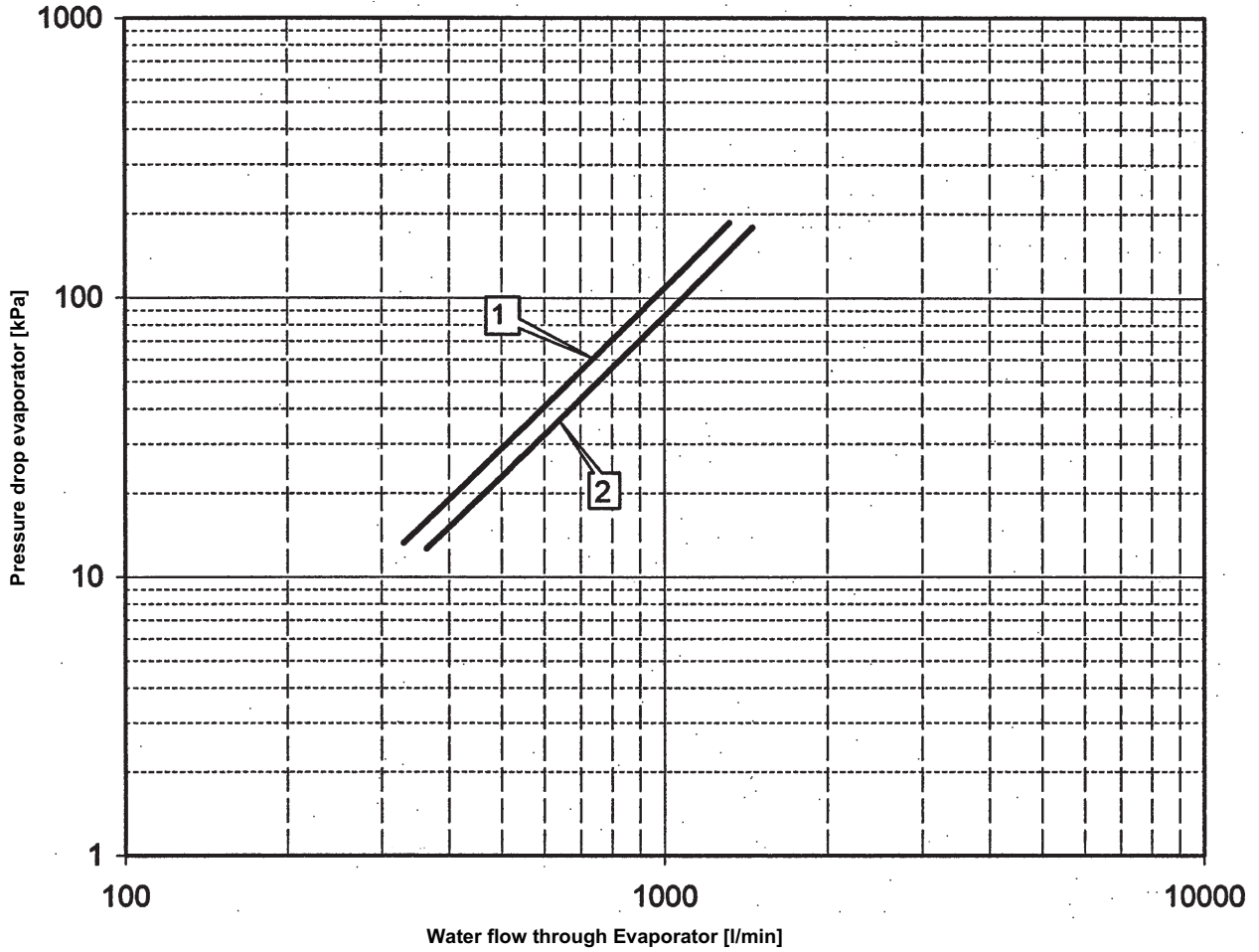

- 1. EWAQ240DAYN\*
- 2. EWAQ260DAYN\*

**Warning:**  
 Selecting a flow outside the curves can cause damage to or malfunction of the unit. See also minimum and maximum allowed water flow range in the technical specifications.

# 11 Hydraulic performance

## 11 - 2 Static Pressure Drop Unit

### EWAQ-DAYN

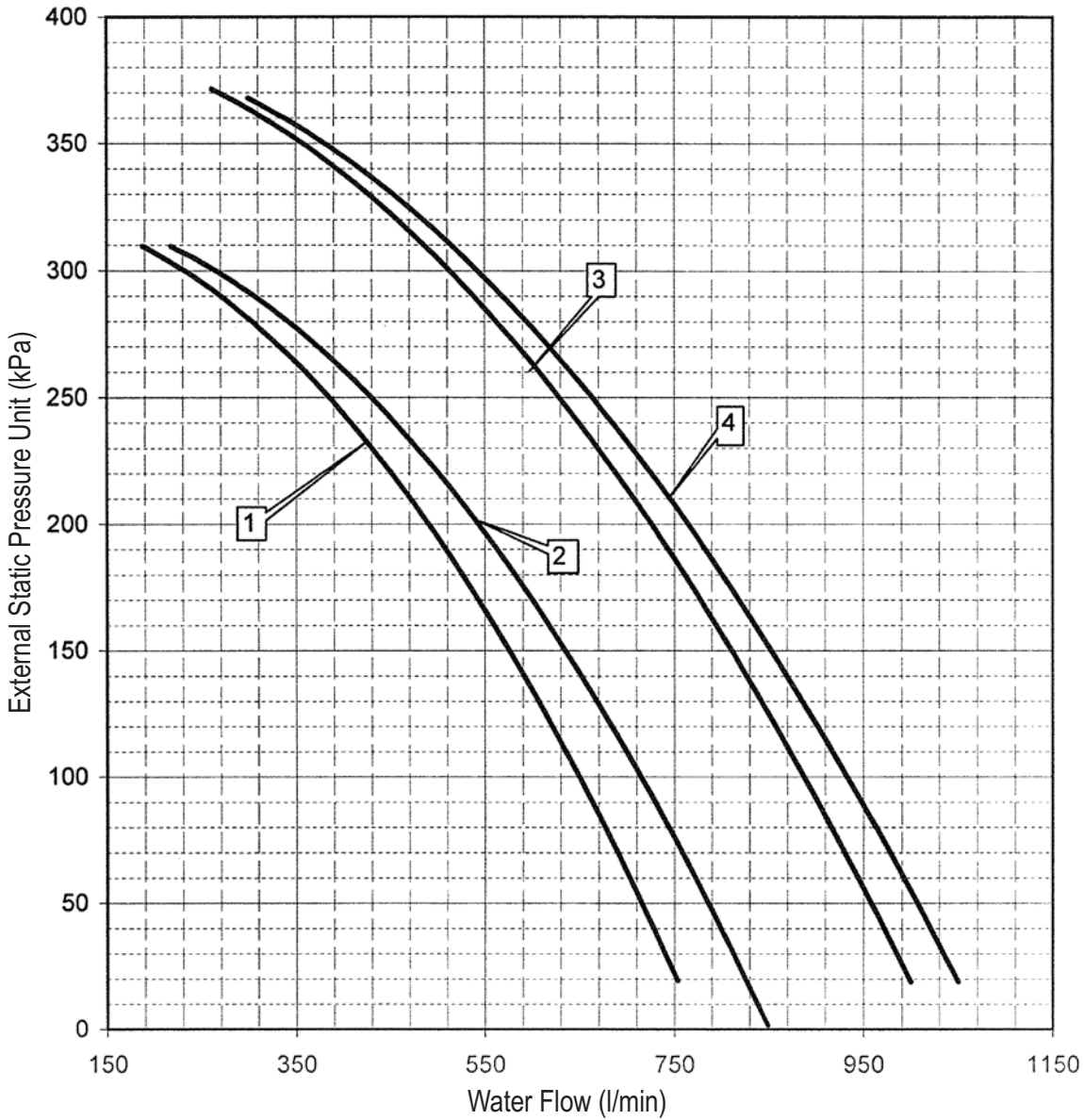

4TW57599-9

#### NOTES

1. EWAQ130DAYN\* + OPHP
2. EWAQ150DAYN\* + OPHP
3. EWAQ180DAYN\* + OPHP
4. EWAQ210DAYN\* + OPHP

#### WARNING

Selecting a flow outside the curves can cause damage to or malfunction of the unit.  
See also minimum and maximum allowed water flowrange in the technical specifications.



# 11 Hydraulic performance

## 11 - 2 Static Pressure Drop Unit

EWAQ080-100DAYN\*

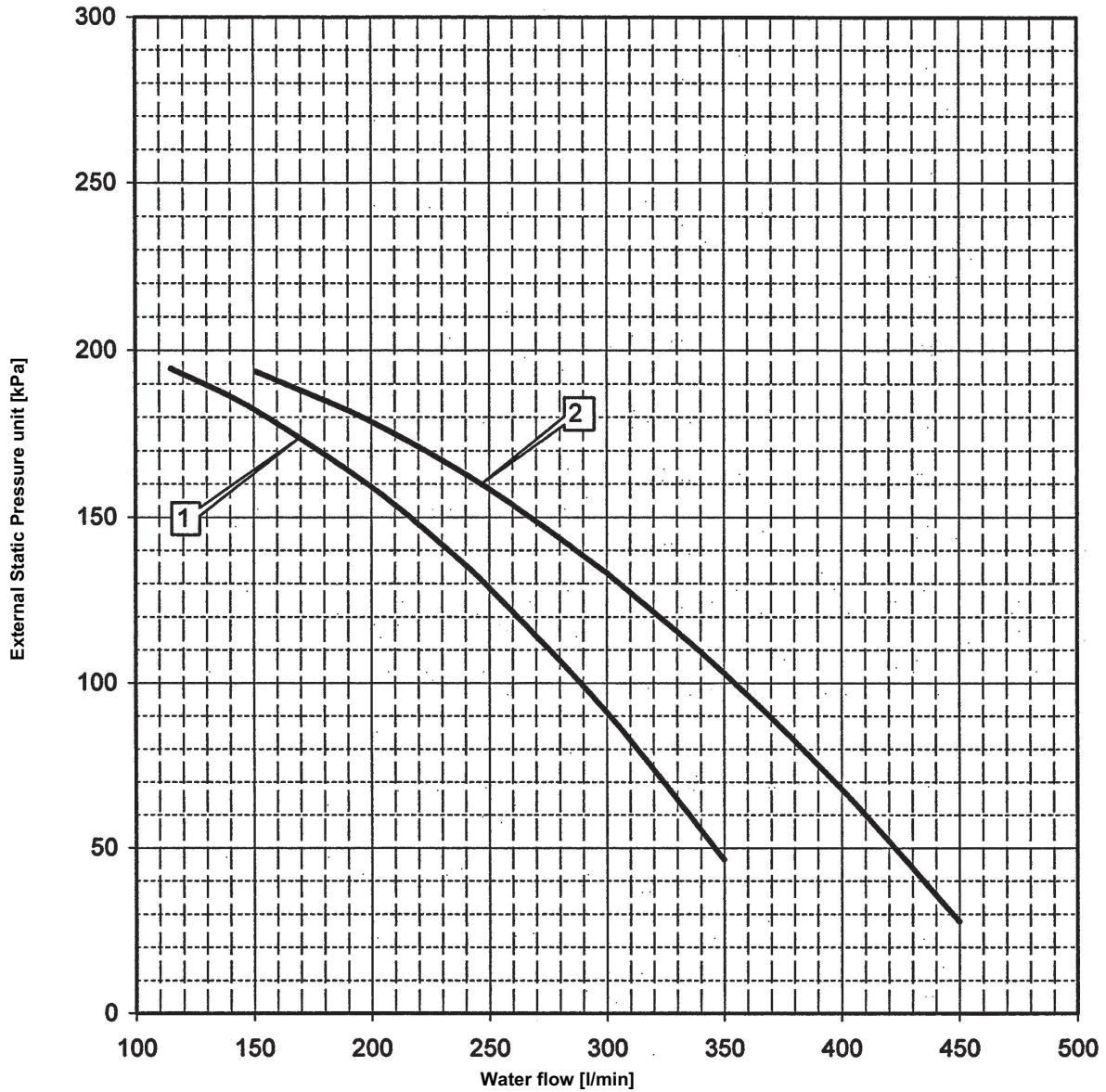

- 1. EWAQ080DAYN\* + OPSP/OTP
- 2. EWAQ100DAYN\* + OPSP/OTP

**Warning:**  
 Selecting a flow outside the curves can cause damage to or malfunction of the unit. See also minimum and maximum allowed water flowrange in the technical specifications.



# 11 Hydraulic performance

## 11 - 2 Static Pressure Drop Unit

EWAQ080-100DAYN(N)

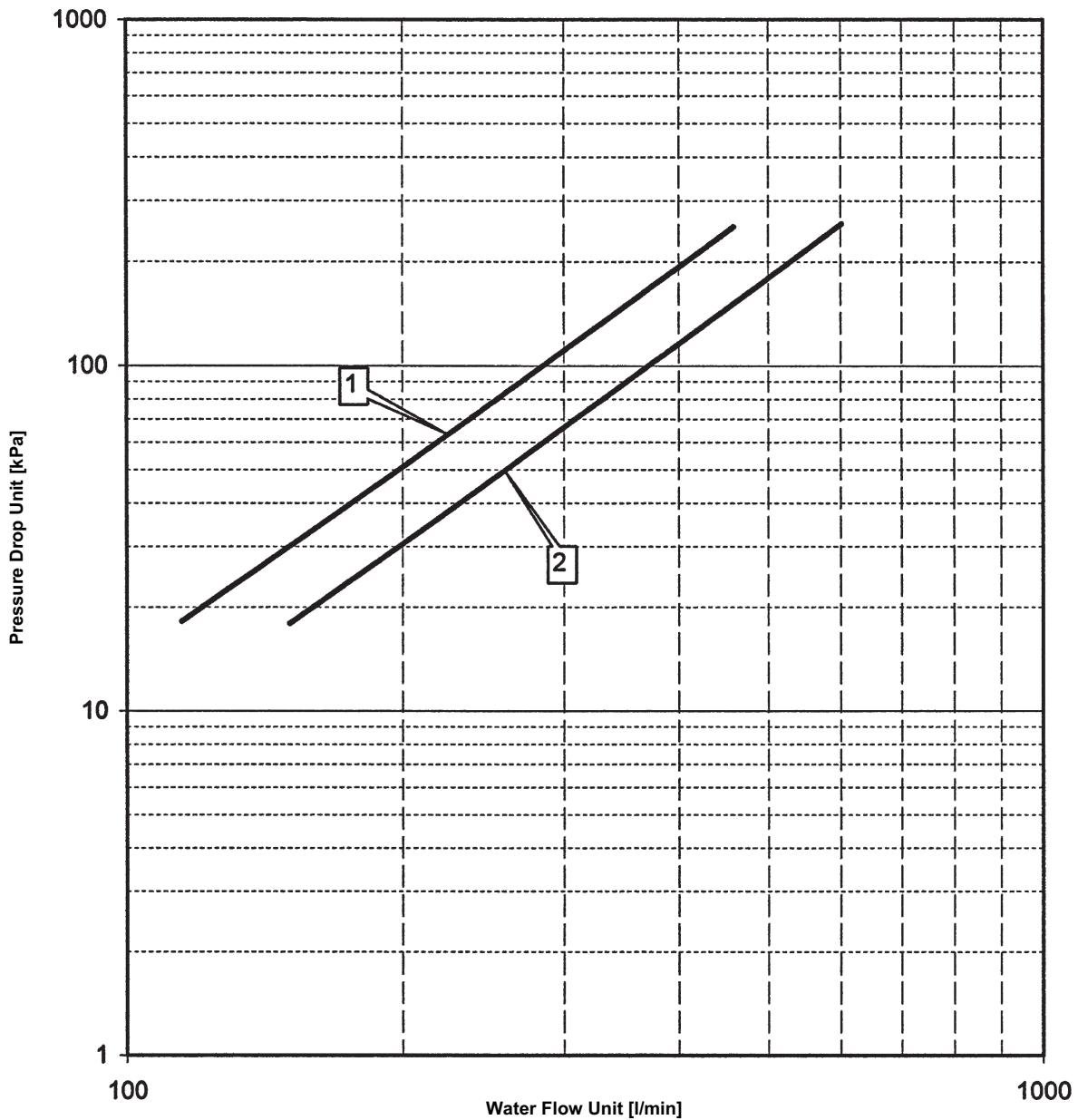

- 1. EWAQ080DAYN\* Standard model
- 2. EWAQ100DAYN\* Standard model

**Warning:**

Selecting a flow outside the curves can cause damage to or malfunction of the unit. See also minimum and maximum allowed water flowrange in the technical specifications.

4TW57579-7.

# 11 Hydraulic performance

## 11 - 2 Static Pressure Drop Unit

EWAQ080-100DAYN(OPHP)

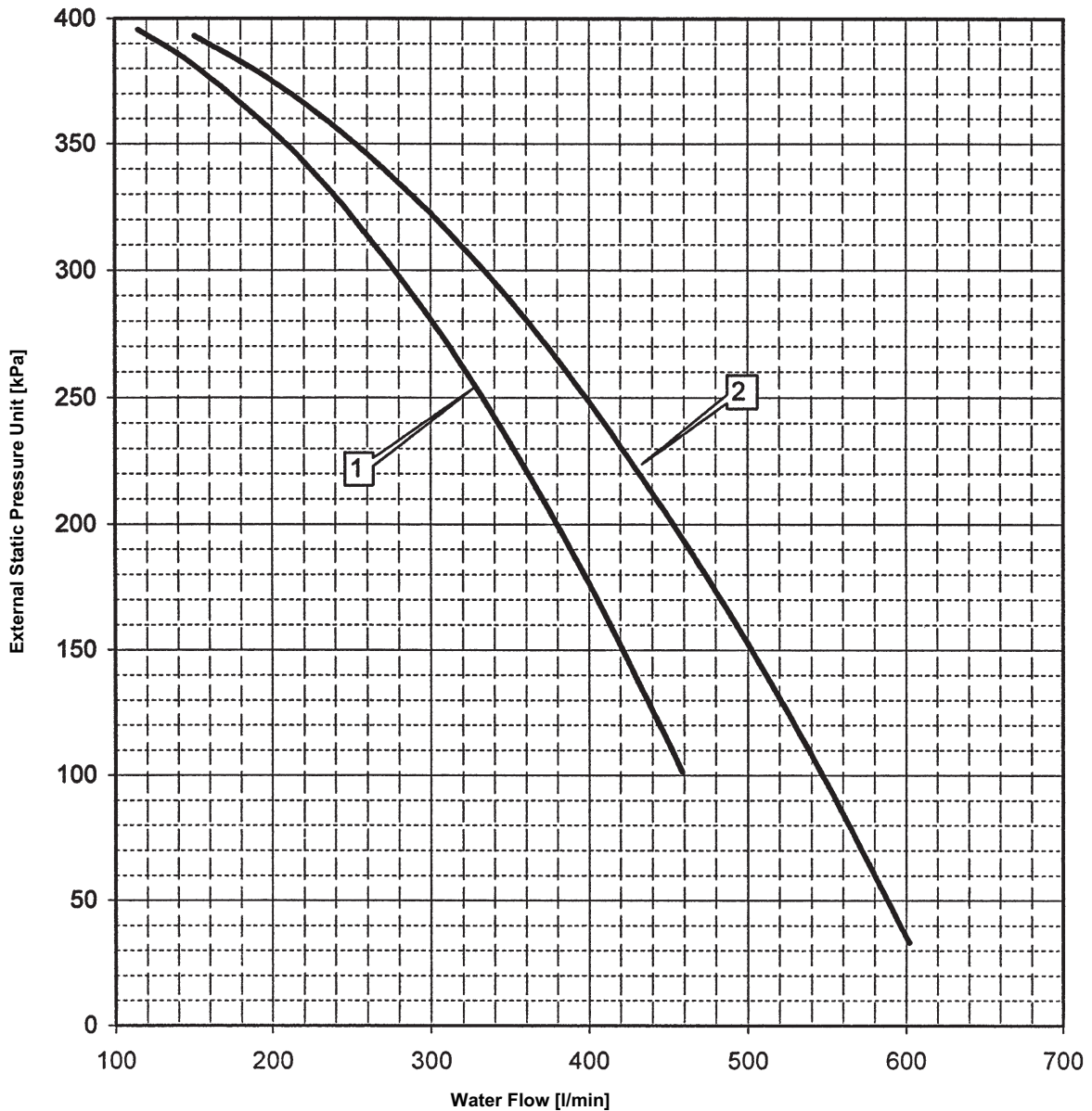

- 1. EWAQ080DAYN\* + OPHP
- 2. EWAQ100DAYN\* + OPHP

**Warning:**

Selecting a flow outside the curves can cause damage to or malfunction of the unit. See also minimum and maximum allowed water flowrange in the technical specifications.

4TW57579-9.

# 11 Hydraulic performance

## 11 - 2 Static Pressure Drop Unit

EWAQ130-210DAYN\*

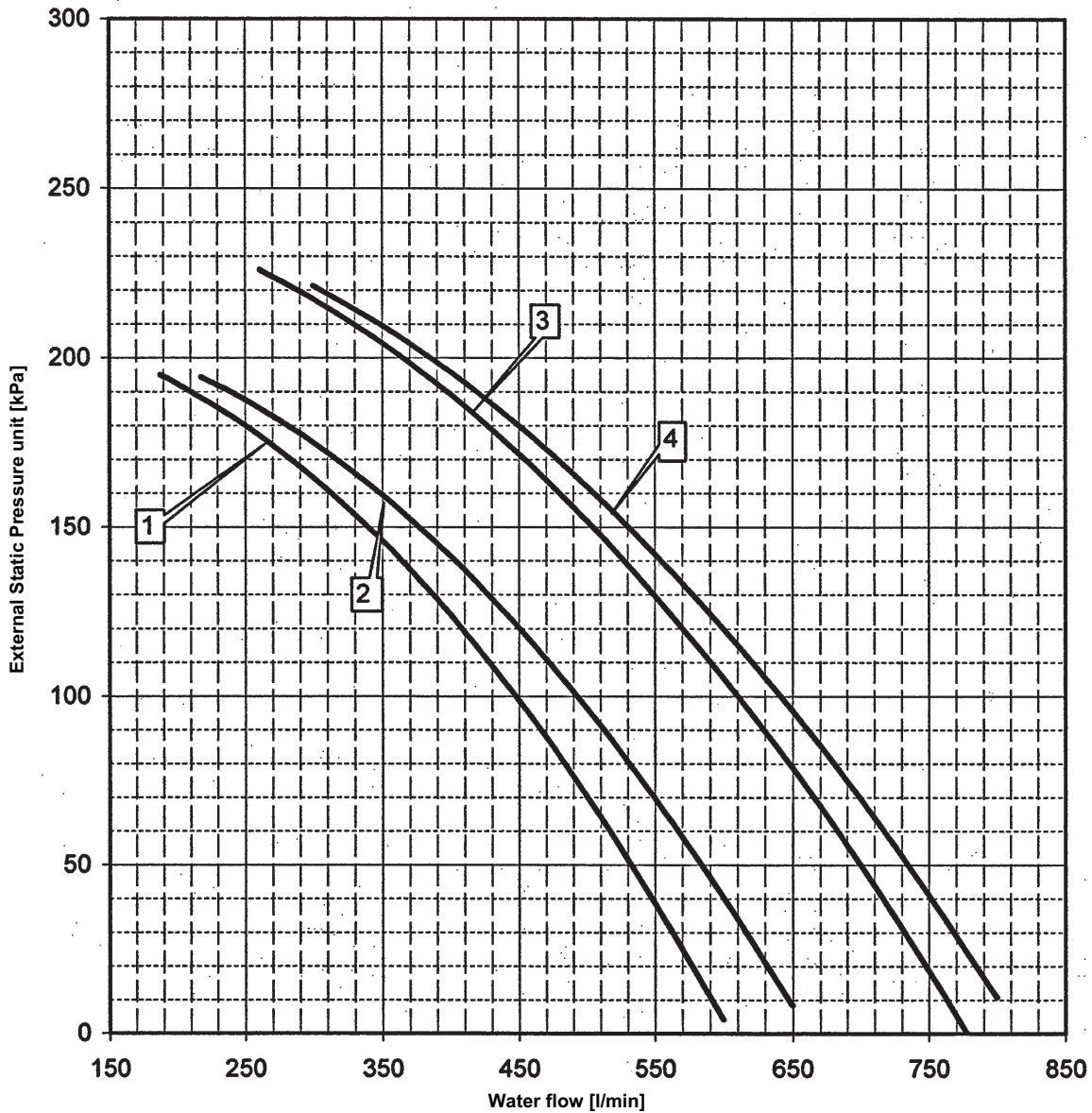

- 1. EWAQ130DAYN\* + OPSP/OTP
- 2. EWAQ150DAYN\* + OPSP/OTP
- 3. EWAQ180DAYN\* + OPSP/OTP
- 4. EWAQ210DAYN\* + OPSP/OTP

**Warning:**

Selecting a flow outside the curves can cause damage to or malfunction of the unit. See also minimum and maximum allowed water flowrange in the technical specifications.

4TW57599-4A

# 11 Hydraulic performance

## 11 - 2 Static Pressure Drop Unit

EWAQ130-210DAYN(N)

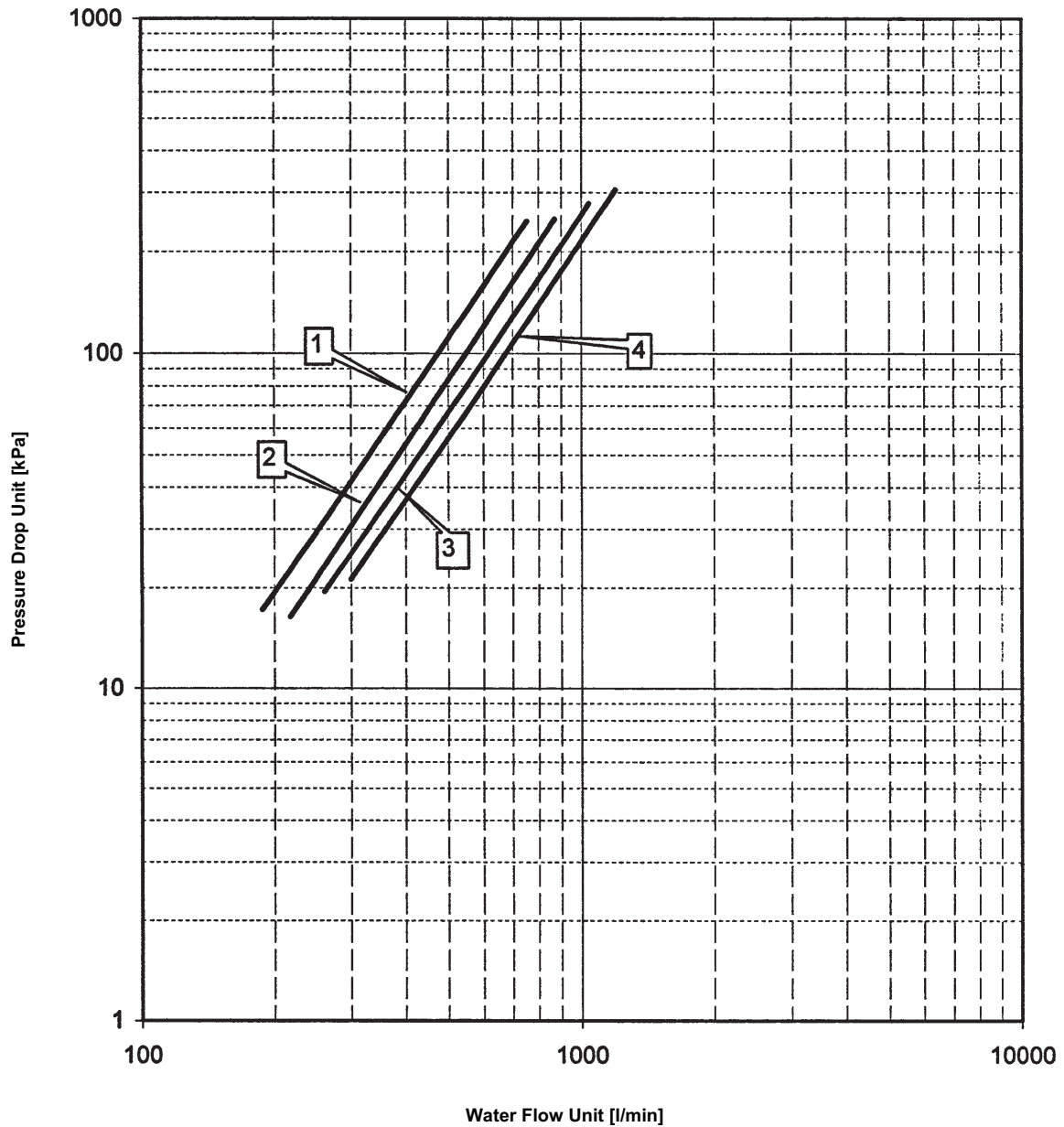

1. EWAQ130DAYN\* Standard model
2. EWAQ150DAYN\* Standard model
3. EWAQ180DAYN\* Standard model
4. EWAQ210DAYN\* Standard model

**Warning:**

Selecting a flow outside the curves can cause damage to or malfunction of the unit. See also minimum and maximum allowed water flowrange in the technical specifications.

# 11 Hydraulic performance

## 11 - 2 Static Pressure Drop Unit

EWAQ240-260DAYN\*

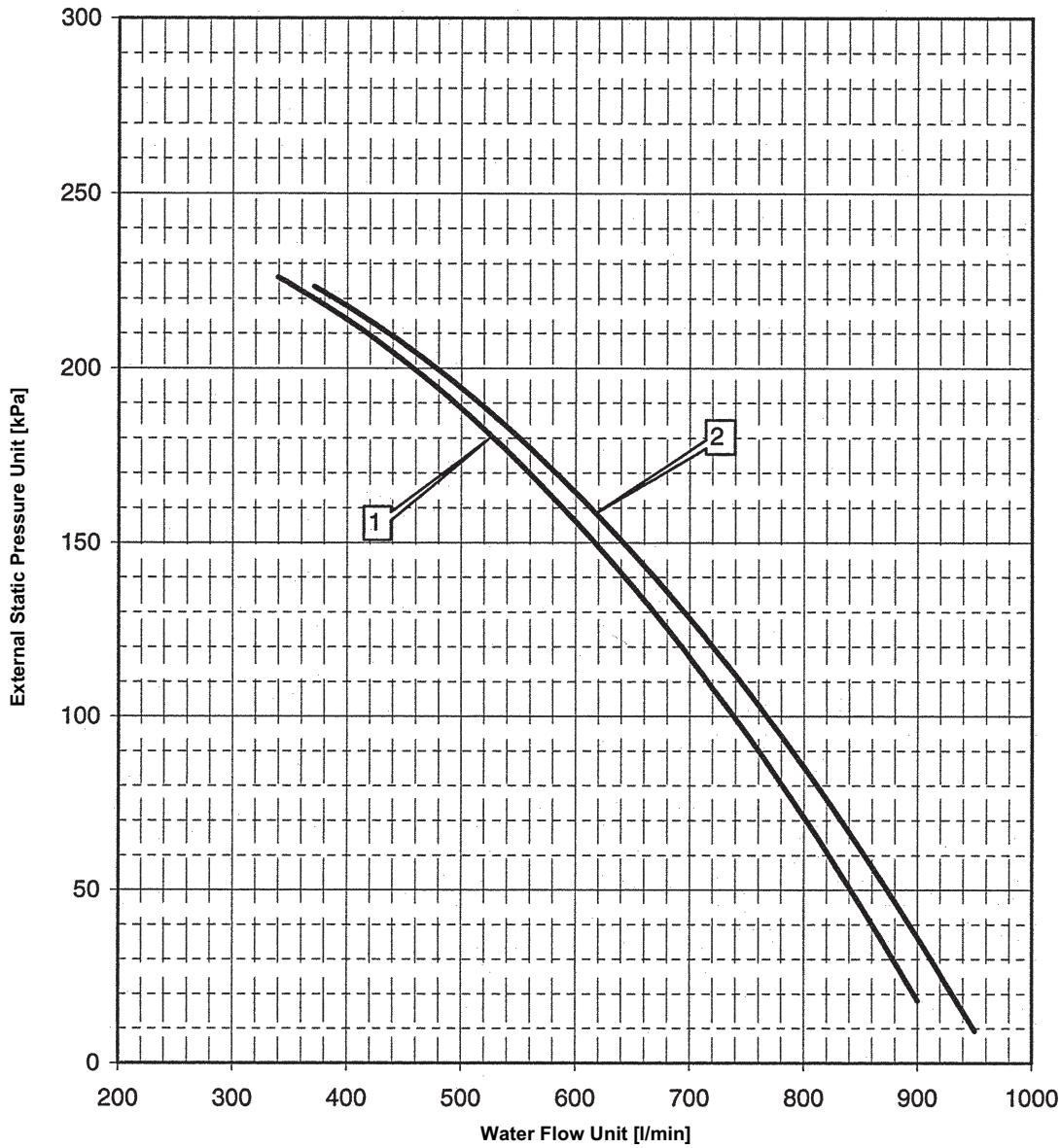

- 1. EWAQ240DAYN\* + OPSP/OPTP
- 2. EWAQ260DAYN\* + OPSP/OPTP

**Warning:**

Selecting a flow outside the curves can cause damage to or malfunction of the unit. See also minimum and maximum allowed water flowrange in the technical specifications.

4TW57639-4B

# 11 Hydraulic performance

## 11 - 2 Static Pressure Drop Unit

EWAQ240-260DAYN(OPHP)

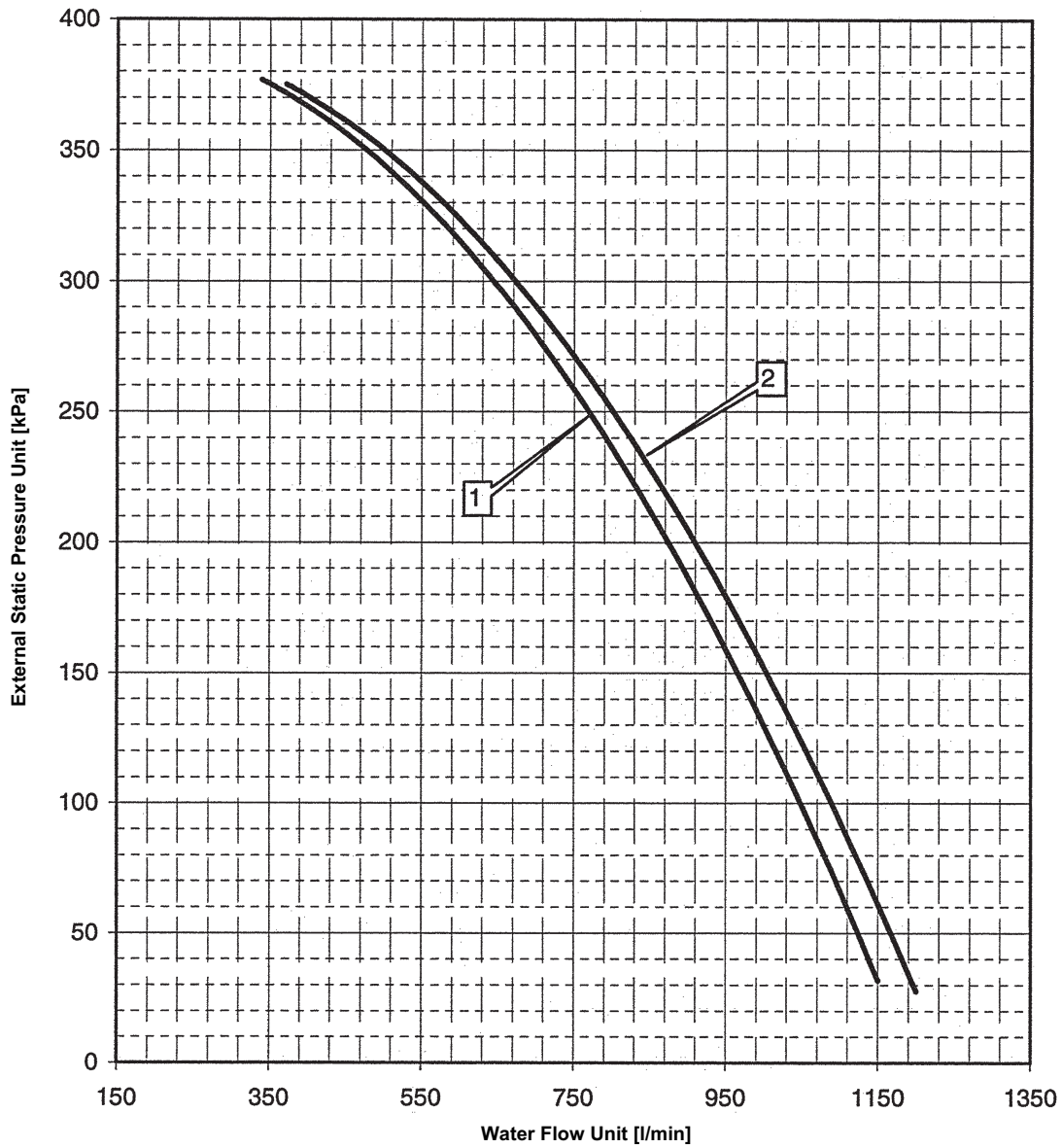

1. EWAQ240DAYN\* + OPHP
2. EWAQ260DAYN\* + OPHP

**Warning:**

Selecting a flow outside the curves can cause damage to or malfunction of the unit. See also minimum and maximum allowed water flowrange in the technical specifications.

# 11 Hydraulic performance

## 11 - 2 Static Pressure Drop Unit

EWAQ240-260DAYN(N)

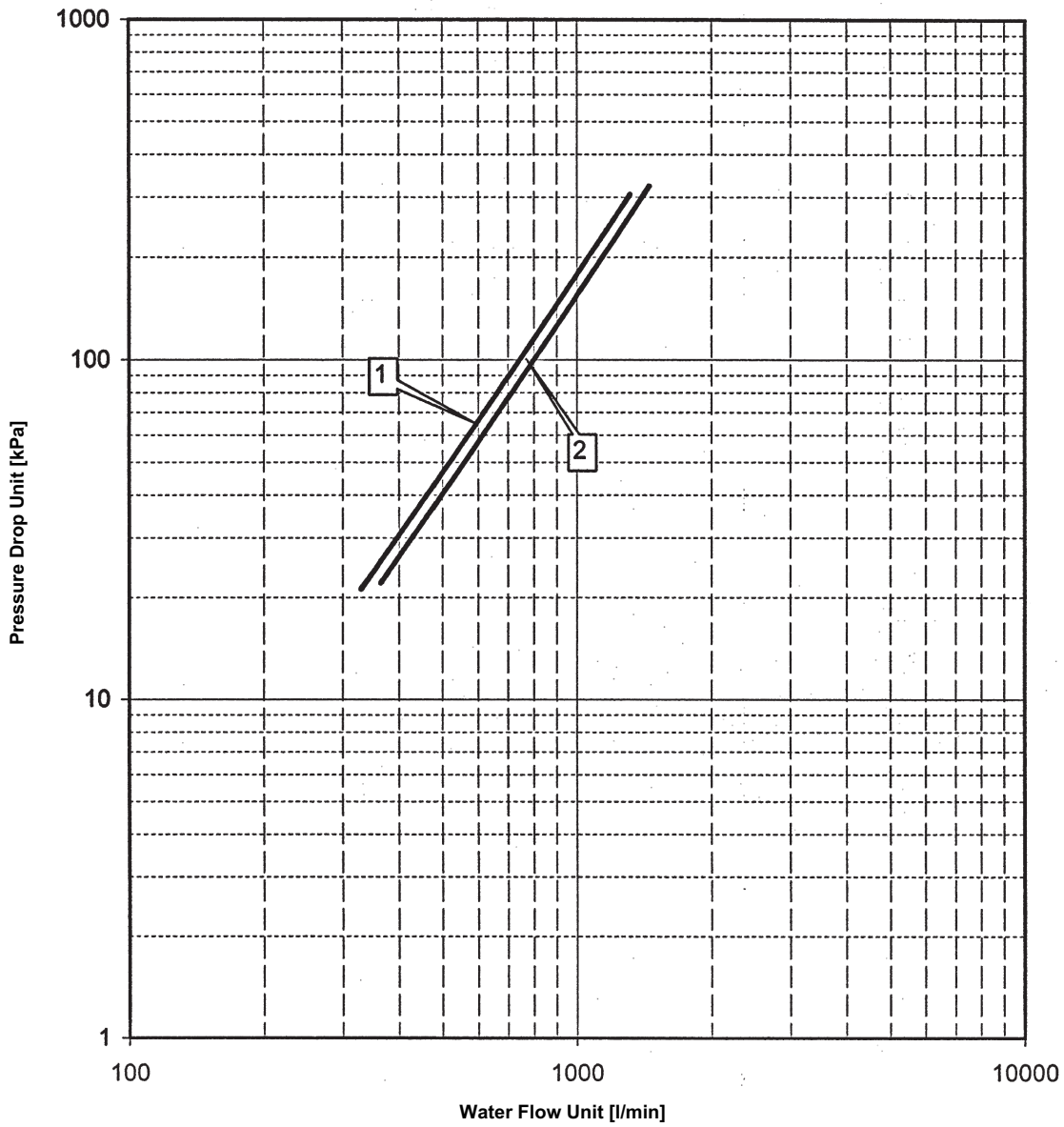

1. EWAQ240DAYN\* Standard model
2. EWAQ260DAYN\* Standard model

**Warning:**

Selecting a flow outside the curves can cause damage to or malfunction of the unit. See also minimum and maximum allowed water flowrange in the technical specifications.

4TW57639-7





# TABLE OF CONTENTS

## EWYQ-DAYN

1	Features .....	44
2	Specifications .....	45
	Technical Specifications .....	45
	Electrical Specifications .....	47
3	Options .....	48
	Options .....	48
4	Capacity tables .....	54
	Cooling Capacity Tables .....	54
	Heating Capacity Tables .....	56
	Capacity Correction Factor .....	57
5	Dimensional drawings .....	58
	Dimensional Drawings .....	58
6	Piping diagrams .....	62
	Piping Diagrams .....	62
7	External connection diagrams .....	66
	External Connection Diagrams .....	66
8	Sound data .....	67
	Sound Power Spectrum .....	67
9	Installation .....	68
	Fixation and Foundation of Units .....	68
	Water Charge, Flow and Quality .....	71
10	Operation range .....	72
	Operation Range .....	72
11	Hydraulic performance .....	74
	Water Pressure Drop Curve Evaporator .....	74
	Static Pressure Drop Unit .....	82

# 1 Features

- Wide capacity range: 80 to 250kW with 8 heat pump models
- Optimised for use with R-410A
- Multiple refrigerant circuits and multiple compressors per circuit
- Reliable and efficient scroll with high EER values
- Anti-corrosion treated aluminium coils
- Low operating sound level
- Easy 'plug and play' installation
- Unit dimensions allow easy transportation
- Fans protected against abnormal operation (4 to 8 fans depending on unit size)
- Safety valves in each circuit
- Electronic circuit breakers
- Electronic expansion valve
- True dual plate brazed plate heat exchanger
- Sight glass
- All hydraulics can be accessed easily from 3 sides (no surrounding cabinet)
- Separate switchbox for easy access
- Compressors and controls at unit side
- Increased reliability via 2 independent refrigerant circuits
- Non hermetic filter/dryer
- Daikin Pcaso controller with user friendly and powerful LCD interface



2  
1

## 2 Specifications

2-1 Technical Specifications				EWYQ080DAYN	EWYQ100DAYN	EWYQ130DAYN	EWYQ150DAYN	EWYQ180DAYN	EWYQ210DAYN	EWYQ230DAYN	EWYQ250DAYN	
Cooling capacity	Nom.	kW	77 (1)	100 (1)	136 (1)	145 (1)	183 (1)	211 (1)	231 (1)	252 (1)		
Heating capacity	Nom.	kW	87.7 (4)	114 (4)	149 (4)	165 (4)	199 (4)	225.00 (4)	258 (4)	281 (4)		
Capacity steps		%	0-50-100		0-25-50-75-100		21/29-43/50/ 57-71/79-100	0-25-50- 75-100	22/28-44/50/ 56-72/78-100	0-25-50- 75-100		
Power input	Cooling	Nom.	kW	26.5 (2)	36.2 (2)	47.6 (2)	55.7 (2)	63.8 (2)	75.3 (2)	82.2 (2)	93.5 (2)	
	Heating	Nom.	kW	30.0 (5)	38.1 (5)	49.6 (5)	58.8 (5)	68.0 (5)	77.0 (5)	84.2 (5)	96.6 (5)	
EER			2.91	2.76	2.86	2.60	2.87	2.80	2.81	2.70		
ESEER			4.00	3.81	4.31	4.07	4.33	4.23	4.20	4.00		
COP			2.92	2.99	3.00	2.81	2.93	2.92	3.06	2.91		
Casing	Material	Polyester painted galvanised steel plate										
Dimensions	Unit	Height	mm	2,311								
		Width	mm	2,000								
		Depth	mm	2,566		2,631		3,081		4,850		
Weight	Unit	kg	1,400	1,450	1,550	1,600	1,850	1,900	3,200	3,300		
	Operation weight	kg	1,415	1,465	1,567	1,619	1,875	1,927	3,239	3,342		
	Packed unit	kg	1,450	1,500	1,600	1,650	1,900	1,950	3,250	3,350		
Water heat exchanger	Type	Brazed plate, one per unit										
	Filter	Type	Strainer galvanized									
		Diameter perforations	mm	1								
	Minimum water volume in the system	l	393 (3)	511 (3)	334 (3)	370 (3)	446 (3)	504 (3)	578 (3)	629 (3)		
	Water flow rate	Min.	l/min	110	143	195	208	262	302	331	361	
		Max.	l/min	503	654	854	946	1,141	1,290	1,479	1,611	
	Nominal water flow	Cooling	l/min	221	287	390	416	525	605	662	722	
		Heating	l/min	251	327	427	473	570	645	740	806	
	Nominal water pressure drop	Cooling	Total	kPa	36		43	38	41	44	39	38
		Heating	Total	kPa	47	46	51	49	48	50	48	46
Insulation material	Foamed synthetic elastomer											
Model	Type	PT120		DV47HP		DV58HP						
	Quantity	1										
Air heat exchanger	Type	Cross fin coil/Hi-Xss tubes and poly ethylene coated waffle fins										
	Rows	Quantity	2		3							
	Stages	Quantity	56		48	56		48				
	Fin pitch	mm	1.8									
	Face area	m <sup>2</sup>	2.46		2.11	2.46	3.02		2.11			
	Coils	Quantity	4								8	
Hydraulic components	Unit water volume	l	15		17	19	25	27	39	42		
	Nominal water pressure drop unit	Cooling	kPa	42	43	55	51	61	70		73	
		Heating	kPa	53	56	65	66	72	79	86	91	
Fan	Quantity	4				6			8			
	Air flow rate	Nom.	m <sup>3</sup> /min	780	800	860	1,290		1,600			
	Discharge direction	Vertical										
	Speed	rpm	880		900	970			900			
Fan motor	Output	W	500		600	700			600			
	Quantity	4				6			8			
	Drive	Direct drive										
Sound power level	Cooling	Nom.	dBA	86	88	89	90		91			
Compressor	Type	Scroll compressor										
	Quantity	2		4		2	4	2	4			
	Model	SJ180	SJ240	SJ161	SJ180		SJ240		SJ300			
	Speed	rpm	2,900									
	Oil	Charged volume	l	6.7		3.3	6.7					
Compressor 2	Quantity	-				2		-	2	-		
	Model	-				SJ240		-	SJ300	-		
	Speed	rpm	-				2,900		-	2,900	-	
	Oil	Charged volume	l	-				6.7		-	6.7	-

2  
2

## 2 Specifications

2-1 Technical Specifications					EWYQ080DAYN	EWYQ100DAYN	EWYQ130DAYN	EWYQ150DAYN	EWYQ180DAYN	EWYQ210DAYN	EWYQ230DAYN	EWYQ250DAYN	
Operation range	Water side	Cooling	Min.	°CDB	-10								
			Max.	°CDB	25								
	Air side	Heating	Min.	°CDB	25								
			Max.	°CDB	50								
		Cooling	Min.	°CDB	-15								
			Max.	°CDB	43								
Heating	Min.	°CDB	-10										
	Max.	°CDB	21										
Refrigerant	Type		R-410A										
	Control		Electronic expansion valve										
	Circuits	Quantity	1					2					
Refrigerant circuit	Charge		kg	33	37	22	32	39					
Refrigerant circuit 2	Charge		kg	-		22	32	39					
Refrigerant oil	Type		FVC68D										
Piping connections	Water heat exchanger inlet / outlet			3" OD							3"		
	Water heat exchanger drain			1/2"G									
Safety devices	Item	01	Flowswitch	Overcurrent relays for compressors and fans	High pressure switch								
		02	Reverse phase protector	High pressure switch	Pressure relief valve								
		03	High pressure switch	Pressure relief valve	Low pressure protection	Low pressure safety							
		04	Pressure relief valve	Low pressure safety	Freeze up protection								
		05	Low pressure safety	Freeze up protection	Flowswitch								
		06	Freeze up protection	Flowswitch	Discharge temperature protector								
		07	Electronic protection module compressors	Discharge temperature protector	Reverse phase protector								
		08	Overcurrent relays for compressors and fans	Reverse phase protector	Electronic protection module compressors (only for SJ180, SJ240)	Electronic protection module compressors							
		09	Discharge temperature protector	Electronic protection module compressors (only for SJ180, SJ240)	Overcurrent relays for compressors and fans								

## 2 Specifications

2-2 Electrical Specifications			EWYQ080DAYN	EWYQ100DAYN	EWYQ130DAYN	EWYQ150DAYN	EWYQ180DAYN	EWYQ210DAYN	EWYQ230DAYN	EWYQ250DAYN	
Compressor	Starting current	A	195	215	158	195	215	260			
	Nominal running current (RLA)	A	25	31	19	25	31	40			
	Maximum running current	A	39	51	35	39	51	65			
	Starting method		Direct on line								
	Crankcase heater	W	75	65	75						
Compressor 2	Starting current	A	-	-	-	215	-	260	-	-	
	Nominal running current (RLA)	A	-	-	-	31	-	40	-	-	
	Maximum running current	A	-	-	-	51	-	65	-	-	
	Starting method		-	-	-	Direct on line	-	Direct on line	-	-	
	Crankcase heater	W	-	-	-	75	-	75	-	-	
Power supply	Phase		3~								
	Frequency	Hz	50								
	Voltage	V	400								
	Voltage range	Min.	%	-10							
		Max.	%	10							
Unit	Starting current	A	201	221	161	199	221	266			
	Maximum starting current	A	240	272	269	320	357	368	440	468	
	Current	Zmax	List	No requirements							
	Nominal running current (RLA)	Cooling	A	60	72	88	113	131	144	162.0	181
		Heating	A	96	120	160	177	209	233	262	290
	Recommended fuses according to IEC standard 269-2			3 x 125gL	3 x 160gL	3 x 200gL	3 x 250gL	3 x 300gL	3 x 355gL		
	Fans	Starting method		Direct on line							
Maximum running current		A	1.5	1.4	2.1	1.6					
Control circuit	Phase		1~								
	Frequency	Hz	50								
	Voltage	V	230 (6)								
	Crankcase heater (E1/2HC)	W	2x75	4x65	4x75						

### Notes

- (1) Cooling: entering evaporator water temp. 12°C; leaving evaporator water temp. 7°C; ambient air temp. 35°C; standard: Eurovent
- (2) Cooling: entering evaporator water temp. 12°C; leaving evaporator water temp. 7°C; ambient air temp. 35°C; standard: Eurovent; Power input compressors + fans + electrical circuit
- (3) Minimum required water volume for standard thermostat settings and at nominal conditions.
- (4) Heating: entering condenser water temp. 40°C; leaving condenser water temp. 45°C; ambient air temp. 7°CDB, 6°CWB; standard: Eurovent
- (5) Heating: entering condenser water temp. 40°C; leaving condenser water temp. 45°C; ambient air temp. 7°CDB, 6°CWB (= power input compressors + fans + electrical circuit); standard: Eurovent
- (6) Supplied by factory installed transformers
- (7) Initial starting current = maximum running current 4 fans (1 circuit) + starting current 1 compressor
- (8) Maximum starting current = maximum running current 4 fans + maximum running current 3 compressors + starting current 1 compressor
- (9) See separate drawing for operation range
- (10) Control circuit voltage: AC (supplied by factory installed transformers)
- (11) Initial starting current = maximum running current 3 fans (1 circuit) + starting current 1 compressor
- (12) Maximum starting current = maximum running current 6 fans + maximum running current 3 compressors + starting current 1 compressor
- (13) Control circuit voltage: 24AC (supplied by factory installed transformers)
- (14) Maximum starting current = maximum running current 8 fans + maximum running current 3 compressors + starting current 1 compressor

### 3 Options

#### 3 - 1 Options

Content :2 counterpipes for welding onto fieldpiping

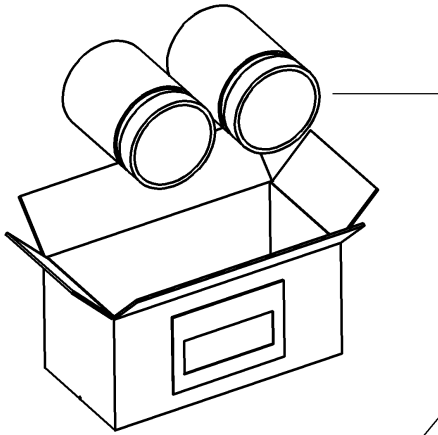

	Weight
EKGN210	2.0 kg
EKGN260	2.5 kg

Box : 200 x 100 x 100

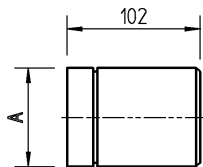

\* Material : Blank steel  
\* Ps = 10 bar

	Ø	A
EKGN210	3" OD	76.1
EKGN260	3"	88.9

EWA/YQ080DAYN*	3" OD
EWA/YQ100DAYN*	
EWA/YQ130DAYN*	
EWA/YQ150DAYN*	
EWA/YQ180DAYN*	
EWA/YQ210DAYN*	3"
EWAQ240DAYN*	
EWAQ260DAYN*	
EWYQ230DAYN*	
EWYQ250DAYN*	

Mounting instructions :

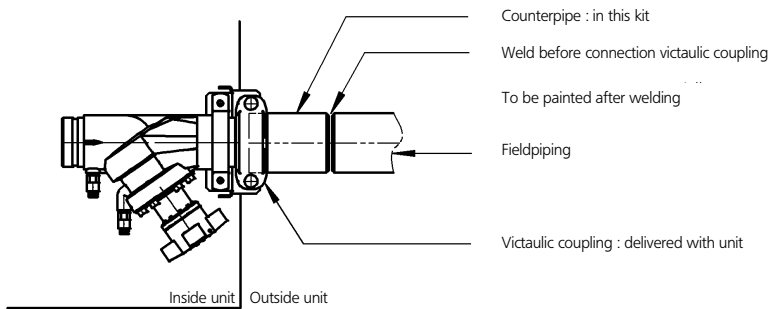

4TW58009-1

# 3 Options

## 3 - 1 Options

### Optional equipment for EWYQ-DAYN

Capacity: 080-250 kW  
 EWYQ080DAYNN EWYQ150DAYNN EWYQ230DAYNN  
 EWYQ100DAYNN EWYQ180DAYNN EWYQ250DAYNN  
 EWYQ130DAYNN EWYQ210DAYNN

Option number	Option description	Unit size								Availability
		080	100	130	150	180	210	230	250	
	Standard unit	0	0	0	0	0	0	0	0	
OPSC	Single pump contactor	0	0	0	0	0	0	0	0	Factory mounted
OPTC	Twin pump contactor	0	0	0	0	0	0	0	0	Factory mounted
OPSP	Single pump	0	0	0	0	0	0	0	0	Factory mounted
OPTP	Twin pump (1 pump house, dual motor)	0	0	0	0	0	0	0	0	Factory mounted
OPHP	high ESP pump (single pump only)	0	0	0	0	0	0	0	0	Factory mounted
OPBT	Buffer tank	0	0	0	0	0	0	0	0	Factory mounted
OPIF	Inverter fans for low ambient (-15 °C)	0	0	0	0	0	0	0	0	Factory mounted
OPZL	Glycol 0°C/-10°C	0	0	0	0	0	0	0	0	Factory mounted
OPO3	Dual pressure relief valve	0	0	0	0	0	0	0	0	Factory mounted
OP10	evaporator heater tape	0	0	0	0	0	0	0	0	Factory mounted
OP12	option valves (discharge-, liquid line- and suction stop valve)	0 (S)	0 (S)	0 (S)	0 (S)	0 (S)	0 (S)	0 (S)	0 (S)	Factory mounted
OP57	A-meter, V-meter	0	0	0	0	0	0	0	0	Factory mounted
OPLN	Low noise = OPIF + compressorhousing	0	0	0	0	0	0	0	0	Factory mounted
OPCG	Condenser protection grilles	0	0	0	0	0	0	0	0	Factory mounted
	<b>Available kits</b>									
EKLONPG	Gateway for LON*	0	0	0	0	0	0	0	0	Kit
EKBNPG	Gateway for BACNET*	0	0	0	0	0	0	0	0	Kit
EKACPG	Address card including	0	0	0	0	0	0	0	0	Kit
	Daikin Integrated Chiller Network (DICON)									
	Serial Communication (Modbus)									
EKRUPG	Remote user interface	0	0	0	0	0	0	0	0	Kit
EKGN210	Waterpipe kit	0	0	0	0	0	-	-	-	Kit
EKGN260	Waterpipe kit	-	-	-	-	-	-	0	0	Kit

- Notes**  
 o Available  
 - Not available  
 (S) option required for swedish national law SNFS1992:16

\* To install EKLONPG & EKBNPG => EKACPG needs to be installed on the unit.  
 For the EKLONPG & EKBNPG design guide, please contact your local dealer.

3TW57659-8B

### EWYQ080-100DAYN

TECHNICAL SPECIFICATIONS OPTIONS				
<b>OPSP</b>				
<b>Units</b>		EWYQ080DAYN		EWYQ100DAYN
Weight	Additional machine weight	kg	250	
	Additional operation weight	kg	268	
	Additional gross weight	kg	250	
Pump	Type	Single stage in line pumps		
	Quantity	1		
	Manufacturer	Grundfos		
	Model	TP50-240/2		
	Efficiency	85.9%		
	Efficiency level	IE3		
	Rated speed	rpm	2890-2910	
Hydraulic components	Nominal static height unit cooling	kPa	173	154
	Buffertank	l	-	
	Additional unit water volume	l	18	
	Expansion vessel	l	35	
	Pre-charge pressure exp. vessel	bar	1.5	
Safety valve	bar	3		
<b>OPHP</b>				
<b>Units</b>		EWYQ080DAYN		EWYQ100DAYN
Pump	Type	Single stage in line pumps		
	Quantity	1		
	Manufacturer	Grundfos		
	Model	TP50-430/2		
	Efficiency	89.2%		
	Efficiency level	IE3		
	Rated speed	rpm	2920-2940	
Nominal static height unit cooling	kPa	365	348	
<b>OPSP + OPBT</b>				
		EWYQ080DAYN		EWYQ100DAYN
Weight		300		
		508		
		300		
Pump		Single stage in line pumps		
		1		
		Grundfos		
		TP50-240/2		
		85.9%		
		IE3		
		2890-2910		
Hydraulic components		173	154	
		190		
		208		
		35		
		1.5		
		3		
<b>OPTP</b>				
		EWYQ080DAYN		EWYQ100DAYN
Pump		Single stage in line pumps		
		1		
		Grundfos		
		TPD50-240/2		
		85.9%		
		IE3		
		2890-2910		
		See OPSP		

3TW57651-1C



### 3 Options

#### 3 - 1 Options

2  
3

#### EWYQ080-100DAYN

ELECTRICAL SPECIFICATIONS OPTIONS				
OPSP / OPTP		EWYQ080DAYN		EWYQ100DAYN
<b>Units</b>				
Std pump	Starting method	Direct on-line		
	Rated power output	kW	2.2	
	Maximum running current	A	4.45	
	Starting current	A	42	
<b>OPHP</b>				
<b>Units</b>		EWYQ080DAYN		EWYQ100DAYN
High ESP pump	Starting method	Direct on-line		
	Rated power output	kW	5.5	
	Maximum running current	A	11.2	
	Starting current	A	131	
<b>OP10</b>				
<b>Units</b>		EWYQ080DAYN		EWYQ100DAYN
Heater tape	Supply voltage	V	230+/-10%	
	Recommended fuses	A	2x10	
	Power standard model	W	1x300	
	Power model with pump	W	2x300	
	Power model with pump and buffertank	W	2x300 + 1x150	

3TW57651-1C

#### EWYQ130-150DAYN

TECHNICAL SPECIFICATIONS OPTIONS					
OPSP			EWYQ130DAYN		EWYQ150DAYN
<b>Units</b>					
Weight	Additional machine weight	kg	250		
	Additional operation weight	kg	286		
	Additional gross weight	kg	250		
Pump	Type	Single stage in line pumps			
	Quantity	1			
	Manufacturer	Grundfos			
	Model	TP65-230/2			
	Efficiency	87.1%			
	Efficiency level	IE3			
	Rated speed	rpm	2900-2920		
Hydraulic components	Nominal static height unit cooling	kPa	141		
	Buffertank	l	-		
	Additional unit water volume	l	36		
	Expansion vessel	l	35		
	Pre-charge pressure exp. vessel	bar	1.5		
Safety valve	bar	3			
<b>OPSP + OPBT</b>					
			EWYQ130DAYN		EWYQ150DAYN
			300		
			526		
			300		
			Single stage in line pumps		
			1		
			Grundfos		
			TP65-230/2		
			87.1%		
			IE3		
			2900-2920		
			141		
			190		
			226		
			35		
			1.5		
			3		
<b>OPHP</b>					
<b>Units</b>		EWYQ130DAYN		EWYQ150DAYN	
Pump	Type	Single stage in line pumps			
	Quantity	1			
	Manufacturer	Grundfos			
	Model	TP65-340/2			
	Efficiency	89.2%			
	Efficiency level	IE3			
	Rated speed	rpm	2920-2940		
Nominal static height unit cooling	kPa	261			
<b>OPTP</b>					
			EWYQ130DAYN		EWYQ150DAYN
			Single stage in line pumps		
			1		
			Grundfos		
			TPD65-230/2		
			87.1%		
			IE3		
			2900-2920		
			See OPSP		

3TW57671-1D

### 3 Options

#### 3 - 1 Options

##### EWYQ130-150DAYN

ELECTRICAL SPECIFICATIONS OPTIONS					
OPSP / OPTP		EWYQ130DAYN		EWYQ150DAYN	
<b>Units</b>					
Std pump	Starting method	Direct on-line			
	Rated power output	kW	3		
	Maximum running current	A	6.3		
	Starting current	A	58		
<b>OPHP</b>					
<b>Units</b>		EWYQ130DAYN		EWYQ150DAYN	
High ESP pump	Starting method	Direct on-line			
	Rated power output	kW	5.5		
	Maximum running current	A	11.2		
	Starting current	A	131		
<b>OP10</b>					
<b>Units</b>		EWYQ130DAYN		EWYQ150DAYN	
Heater tape	Supply voltage	V	230+/-10%		
	Recommended fuses	A	2x10		
	Power standard model	W	1x300		
	Power model with pump	W	2x300		
	Power model with pump and buffertank	W	2x300 + 1x150		

3TW57671-1D

##### EWYQ180-210DAYN

TECHNICAL SPECIFICATIONS OPTIONS						
OPSP			EWYQ180DAYN		EWYQ210DAYN	
<b>Units</b>						
Weight	Additional machine weight	kg	250		300	
	Additional operation weight	kg	286		526	
	Additional gross weight	kg	250		300	
Pump	Type	Single stage in line pumps				
	Quantity	1				
	Manufacturer	Grundfos				
	Model	TP65-260/2				
	Efficiency	88.1%				
	Efficiency level	IE3				
	Rated speed	rpm	2920-2940		2920-2940	
	Nominal static height unit cooling	kPa	152		128	152
Hydraulic components	Buffertank	l	-		190	
	Additional unit water volume	l	36		226	
	Expansion vessel	l	35		35	
	Pre-charge pressure exp. vessel	bar	1.5		1.5	
	Safety valve	bar	3		3	
<b>OPHP</b>						
<b>Units</b>		EWYQ180DAYN		EWYQ210DAYN		
Pump	Type	Single stage in line pumps				
	Quantity	1				
	Manufacturer	Grundfos				
	Model	TP65-410/2				
	Efficiency	90.4%				
	Efficiency level	IE3				
	Rated speed	rpm	2910-2920		2920-2940	
	Nominal static height unit cooling	kPa	306		286	See OPSP
<b>OPTP</b>						
<b>Units</b>		EWYQ180DAYN		EWYQ210DAYN		
Single stage in line pumps						
1						
Grundfos						
TPD65-260/2						
88.1%						
IE3						
2920-2940						

3TW57691-1D

### 3 Options

#### 3 - 1 Options

2  
3

#### EWYQ180-210DAYN

ELECTRICAL SPECIFICATIONS OPTIONS				
OPSP / OPTP		EWYQ180DAYN		EWYQ210DAYN
<b>Units</b>				
Std pump	Starting method	Direct on-line		
	Rated power output	kW	4	
	Maximum running current	A	8	
	Starting current	A	98	
<b>OPHP</b>				
<b>Units</b>		EWYQ180DAYN		EWYQ210DAYN
High ESP pump	Starting method	Direct on-line		
	Rated power output	kW	7.5	
	Maximum running current	A	15.2	
	Starting current	A	169	
<b>OP10</b>				
<b>Units</b>		EWYQ180DAYN		EWYQ210DAYN
Heater tape	Supply voltage	V	230+/-10%	
	Recommended fuses	A	2x10	
	Power standard model	W	1x300	
	Power model with pump	W	2x300	
	Power model with pump and buffertank	W	2x300 + 1x150	

3TW57691-1D

#### EWYQ230-250DAYN

TECHNICAL SPECIFICATIONS OPTIONS					
OPSP			EWYQ230DAYN		EWYQ250DAYN
<b>Units</b>					
Weight	Additional machine weight	kg	250		
	Additional operation weight	kg	271		
	Additional gross weight	kg	250		
Pump	Type	Single stage in line pumps			
	Quantity	1			
	Manufacturer	Grundfos			
	Model	TP65-260/2			
	Efficiency	88.1%			
	Efficiency level	IE3			
	Rated speed	rpm	2920-2940		
Hydraulic components	Nominal static height unit cooling	kPa	143	127	
	Buffertank	l	-		
	Additional unit water volume	l	21		
	Expansion vessel	l	50		
	Pre-charge pressure exp. vessel	bar	1.5		
Safety valve	bar	3			
<b>OPSP + OPBT</b>					
			EWYQ230DAYN		EWYQ250DAYN
			300		
			511		
			300		
			Single stage in line pumps		
			1		
			Grundfos		
			TP65-260/2		
			88.1%		
			IE3		
			2920-2940		
			143	127	
			190		
			211		
			50		
			1.5		
			3		
<b>OPHP</b>					
<b>Units</b>		EWYQ230DAYN		EWYQ250DAYN	
Pump	Type	Single stage in line pumps			
	Quantity	1			
	Manufacturer	Grundfos			
	Model	TP65-410/2			
	Efficiency	90.4%			
	Efficiency level	IE3			
	Rated speed	rpm	2910-2920		
	Nominal static height unit cooling	kPa	303	290	
<b>OPTP</b>					
			EWYQ230DAYN		EWYQ250DAYN
			Single stage in line pumps		
			1		
			Grundfos		
			TPD65-260/2		
			88.1%		
			IE3		
			2920-2940		
			See OPSP		

3TW57711-1D

### 3 Options

#### 3 - 1 Options

EWYQ230-250DAYN

ELECTRICAL SPECIFICATIONS OPTIONS				
OPSP / OTP		EWYQ230DAYN		EWYQ250DAYN
<b>Units</b>		Direct on-line		
Std pump	Starting method	Direct on-line		
	Rated power output	kW	4	
	Maximum running current	A	8	
	Starting current	A	98	
OPHP		EWYQ230DAYN		EWYQ250DAYN
<b>Units</b>		Direct on-line		
High ESP pump	Starting method	Direct on-line		
	Rated power output	kW	7.5	
	Maximum running current	A	15.2	
	Starting current	A	169	
OP10		EWYQ230DAYN		EWYQ250DAYN
<b>Units</b>		230+/-10%		
Heater tape	Supply voltage	V	230+/-10%	
	Recommended fuses	A	2x10	
	Power standard model	W	1x300	
	Power model with pump	W	2x300	
	Power model with pump and buffertank	W	2x300 + 1x150	

3TW57711-1D

2

3

# 4 Capacity tables

## 4 - 1 Cooling Capacity Tables

EWYQ-DAYN

COOLING													
Tamb (°C)		20		25		30		35		40		43	
LWE	Size	CC	PI	CC	PI	CC	PI	CC	PI	CC	PI	CC	PI
5	080	83.1	20.4	79.5	22.1	75.7	24.1	71.7	26.2	64.8	28.7	59.5	30.3
	100	109	26.8	104	29.4	99.2	32.4	93.6	35.8	84.0	39.5	76.9	42.0
	130	148	35.6	142	39.0	135	42.7	127	46.8	117	51.5	109	54.6
	150	161	42.0	154	45.9	146	50.2	137	55.2	125	60.7	117	64.4
	180	199	48.3	190	52.7	181	57.6	171	63.1	159	70.0	151	74.9
	210	234	56.6	223	61.8	211	67.7	198	74.3	183	82.5	173	88.3
	230	252	63.0	241	68.4	230	74.5	217	81.3	195	89.0	179	94.0
250	277	71.6	265	77.8	252	84.7	237	92.5	213	101	194	107	
7	080	89.1	20.5	85.2	22.3	81.2	24.3	77.0	26.5	69.5	28.9	63.9	30.5
	100	117	27.2	112	29.9	106	32.9	100	36.2	89.8	40.0	82.3	42.5
	130	159	36.3	152	39.8	144	43.5	136	47.6	124	52.3	116	55.4
	150	170	42.5	162	46.4	154	50.8	145	55.7	132	61.3	124	65.0
	180	213	49.0	203	53.4	194	58.3	183	63.8	170	70.7	161	75.6
	210	248	57.6	236	62.8	224	68.7	211	75.3	195	83.5	184	89.4
	230	268	63.9	256	69.3	244	75.4	231	82.2	208	89.9	190	94.9
250	294	72.5	281	78.8	267	85.8	252	93.5	226	102	207	108	
10	080	98.6	20.9	94.5	22.6	90.1	24.6	85.4	26.8	77.1	29.3	70.9	30.9
	100	129	28.0	123	30.6	117	33.6	110	37.0	99.0	40.8	90.7	43.2
	130	175	37.5	167	40.9	159	44.7	150	48.9	137	53.5	128	56.7
	150	185	43.3	177	47.3	168	51.8	158	56.8	144	62.4	135	66.1
	180	235	50.2	224	54.5	214	59.5	202	65.0	188	71.9	178	76.8
	210	271	59.2	258	64.4	245	70.3	231	76.9	213	85.2	201	91.1
	230	292	65.3	280	70.7	267	76.8	252	83.7	227	91.3	208	96.4
250	321	74.0	307	80.4	292	87.4	275	95.3	247	104	226	110	
13	080	109	21.2	104	23.0	100	25.0	94.4	27.2	85.2	29.7	78.4	31.3
	100	142	28.8	135	31.4	128	34.4	121	37.8	109	41.6	100	44.1
	130	192	38.7	184	42.2	174	46.0	164	50.2	150	54.9	140	58.0
	150	203	44.4	193	48.5	184	53.0	173	58.1	158	63.7	147	67.4
	180	258	51.4	247	55.8	235	60.8	222	66.3	206	73.3	195	78.2
	210	296	61.0	282	66.2	267	72.1	251	78.7	232	87.0	219	92.9
	230	319	66.8	305	72.3	291	78.4	275	85.3	248	92.9	227	97.9
250	350	75.6	334	82.1	318	89.2	300	97.1	269	106	246	112	
16	080	120	21.5	115	23.4	110	25.4	104	27.7	93.8	30.2	86.3	31.8
	100	155	29.7	148	32.3	141	35.3	133	38.7	119	42.5	109	45.0
	130	210	40.0	201	43.5	191	47.4	179	51.6	164	56.3	153	59.4
	150	222	45.7	212	49.8	201	54.4	189	59.6	173	65.2	161	68.0
	180	283	52.9	270	57.3	257	62.2	243	67.8	226	74.8	214	79.7
	210	321	63.0	306	68.2	290	74.0	273	80.6	252	89.0	238	94.9
	230	346	68.5	332	74.0	316	80.1	299	87.0	269	94.6	247	100
250	380	77.4	363	83.9	345	91.1	326	99.1	292	108	267	114	
20	080	136	22.1	130	24.0	124	26.0	118	28.3	106	30.9	93.4	15.1
	100	174	31.1	166	33.7	158	36.7	149	40.0	133	43.8	119	21.5
	130	236	41.8	225	45.4	213	49.3	201	53.6	183	58.4	166	28.5
	150	252	47.6	240	51.9	227	56.7	213	61.9	194	67.7	179	33.2
	180	317	55.0	304	59.4	289	64.4	273	70.0	253	77.0	231	38.1
	210	357	66.0	341	71.1	323	77.0	304	83.6	280	91.9	261	45.4
	230	385	71.1	369	76.5	352	82.6	333	89.5	300	97.1	281	47.4
250	423	79.9	404	86.5	384	93.8	362	102	325	111	301	54.1	

**SYMBOLS**

- CC : Cooling capacity (kW)
- PI : Power input (kW)
- LWE : Leaving Water Evaporator temperature (°C)
- Tamb : Ambient temperature (°C)

**NOTES**

1. Cooling capacity (CAP)  
Capacity is according to Eurovent rating standard 6/C/003-2006 and valid for chilled water range Dt = 3 - 8°C
2. Power input (kW)  
Power input is total input according to Eurovent rating standard 6/C/003-2006: Compressor + fans + control circuit
3. For units with integrated heat pump  
Values for CC are to be multiplied by 0.99 in order to compensate heat input of the pump

3TW57652-1B

# 4 Capacity tables

## 4 - 1 Cooling Capacity Tables

EWYQ-DAYN

COOLING - OPZL													
Tamb (°C)		20		25		30		35		40		43	
LWE	Size	CC	PI	CC	PI	CC	PI	CC	PI	CC	PI	CC	PI
-10	080	50.1	19.4	47.1	21.2	44.2	23.2	41.4	25.4	37.0	27.9		
	100	65	24.5	61	27.1	58.1	29.9	54.6	33.1	48.9	36.7		
	130	91	31.3	87	34.7	82	38.3	77	42.4	71	47.2		
	150	110	39.3	103	43.1	96	47.4	90	52.2	81	57.8		
	180	118	44.7	112	49.0	105	53.9	99	59.3	91	66.0		
	210	145	51.3	137	56.4	129	62.1	121	68.4	111	76.2		
	230	155	57.9	148	63.2	140	69.1	132	75.7	118	83.0		
250	171	65.9	163	71.7	154	78.2	145	85.5	129	94			
-7	080	55.1	19.5	52.1	21.3	49.1	23.3	46.2	25.5	41.5	28.0		
	100	72	24.8	68	27.5	65	30.3	61	33.6	54.7	37.2		
	130	100	32.0	96	35.4	91	39.0	85	43.1	78	47.8		
	150	119	39.7	112	43.5	105	47.8	98	52.7	89	58.2		
	180	131	45.2	124	49.6	118	54.4	111	59.8	102	66.6		
	210	160	52.1	152	57.3	143	63.0	134	69.4	124	77.3		
	230	172	58.8	164	64.1	155	70.1	146	76.7	131	84.1		
250	189	66.9	180	72.8	171	79.4	161	86.8	144	95			
-5	080	58.9	19.6	55.8	21.4	52.8	23.4	49.7	25.5	44.7	28.0	41.0	29.7
	100	77	25.1	73	27.7	70	30.6	66	33.9	58.9	37.5	53.9	39.9
	130	107	32.5	102	35.9	97	39.5	91	43.6	84	48.3	78	51.5
	150	125	40.0	119	43.9	112	48.1	104	53.0	95	58.5	88	62.2
	180	140	45.6	134	50.0	127	54.8	119	60.3	111	67.1	105	71.9
	210	171	52.7	162	57.9	153	63.7	144	70.1	132	78.1	125	83.8
	230	184	59.4	175	64.7	166	70.7	157	77.4	141	84.9	129	89.8
250	202	67.5	193	73.5	183	80.2	172	87.6	154	96	141	101	
-2	080	65	19.8	62	21.6	59	23.5	55.6	25.7	50.1	28.2	46.0	29.8
	100	86	25.5	82	28.2	78	31.1	73	34.4	66	38.1	60	40.5
	130	118	33.4	113	36.7	107	40.4	101	44.5	92	49.2	86	52.3
	150	135	40.5	128	44.4	121	48.7	114	53.5	103	59.0	96	62.7
	180	156	46.3	149	50.7	141	55.5	133	61.0	124	67.8	117	72.7
	210	188	53.7	179	58.9	169	64.7	159	71.2	146	79.3	138	85.1
	230	202	60.3	193	65.7	184	71.8	174	78.5	156	86.0	143	91.0
250	222	68.7	213	74.7	202	81.5	190	89.0	170	97	156	103	
2	080	75	20.1	71	21.9	68	23.8	64	26.0	58.1	28.4	53.4	30.0
	100	99	26.2	94	28.8	89	31.8	84	35.1	76	38.9	69	41.3
	130	134	34.6	129	38.0	122	41.6	115	45.7	106	50.4	99	53.6
	150	149	41.3	142	45.2	135	49.5	126	54.4	115	59.9	108	63.6
	180	179	47.4	171	51.8	163	56.6	154	62.1	143	69.0	136	73.8
	210	213	55.3	203	60.5	192	66.3	181	72.9	167	81.1	157	86.9
	230	230	61.8	220	67.2	209	73.3	198	80.1	178	87.7	163	93
250	252	70.3	241	76.4	229	83.3	216	90.9	194	99	177	105	

### SYMBOLS

- CC : Cooling capacity (kW)
- PI : Power input (kW)
- LWE : Leaving Water Evaporator temperature (°C)
- Tamb : Ambient temperature (°C)

### NOTES

1. Cooling capacity (kW)  
Capacity is according to Eurovent rating standard 6/C/003-2006 and valid for chilled water range Dt = 3 - 8°C
2. Power input (kW)  
Power input is total input according to Eurovent rating standard 6/C/003-2006: Compressor + fans + control circuit
3. For units with integrated heat pump  
Values for CC are to be multiplied by 0.99 in order to compensate heat input of the pump
4. Usage of glycol and other anti-freeze  
Correction factors for CC and PI are applicable according type and concentration of the used anti-freeze

3TW57572-1B

# 4 Capacity tables

## 4 - 2 Heating Capacity Tables

EWYQ-DAYN

HEATING																			
Tamb (°C)		-10		-7		-4		0		4		7		10		15		21	
LWC	Size	HC	PI	HC	PI	HC	PI	HC	PI	HC	PI	HC	PI	HC	PI	HC	PI	HC	PI
25	080	58.4	19.8	64.5	20.0	70.5	20.1	78.0	20.3	86.0	20.6	92.4	20.9	99.0	21.1	110	21.6	125	22.2
	100	74.1	23.9	82.3	24.2	90.3	24.4	100	24.8	111	25.2	119	25.5	127	25.9	142	26.5	159	27.3
	130	97	31.7	108	32.2	118	32.7	131	33.4	145	34.1	156	34.7	167	35.3	186	36.3	210	37.4
	150	107	40.0	118	40.0	129	40.1	143	40.2	157	40.5	168	40.7	179	40.9	199	41.4	223	41.9
	180	129	44.1	144	44.5	158	44.9	176	45.5	194	46.2	208	46.7	222	47.3	246	48.3	273	49.5
	210	141	50.7	158	51.0	174	51.3	193	51.6	214	52.0	229	52.3	244	52.6	270	53.3	299	54.1
	230	160	54.3	179	54.9	198	55.5	222	56.2	248	57.1	269	57.7	292	58.4	332	59.7	385	61.5
250	175	62.1	195	62.9	216	63.8	242	64.9	270	66.1	293	67.0	317	67.9	360	69.6	416	71.8	
30	080	57.4	21.8	63.3	21.9	69.8	22.0	77.2	22.2	85.0	22.5	91.2	22.8	97.6	23.0	109	23.5	123	24.2
	100	73.2	26.4	81.2	26.7	89.8	27.0	99.5	27.4	110	27.8	118	28.2	126	28.5	140	29.1	157	30.0
	130	96	34.8	106	35.3	117	35.8	130	36.5	144	37.2	154	37.8	165	38.4	184	39.4	207	40.6
	150	106	44.1	117	44.0	129	44.0	142	44.1	156	44.3	167	44.5	178	44.7	197	45.1	221	45.7
	180	127	48.5	142	48.9	157	49.3	174	49.9	192	50.6	206	51.2	220	51.7	243	52.8	269	54.0
	210	140	55.8	157	56.2	174	56.5	193	56.8	213	57.2	228	57.5	243	57.8	268	58.3	296	59.1
	230	158	59.5	177	60.2	197	60.8	221	61.7	246	62.5	267	63.2	288	64.0	327	65.3	379	67.2
250	173	67.8	193	68.7	215	69.7	241	70.9	268	72.2	290	73.2	313	74.2	355	76.0	409	78.4	
35	080	56.6	24.0	62.4	24.1	68.7	24.2	76.5	24.4	84.1	24.7	90.0	24.9	96.3	25.2	107	25.7	121	26.4
	100	72.5	29.1	80.4	29.5	88.7	29.8	99.0	30.3	109	30.7	116	31.1	124	31.5	138	32.1	155	33.0
	130	95	38.4	105	38.8	116	39.3	129	39.9	142	40.7	153	41.2	163	41.8	181	42.9	204	44.1
	150	105	48.6	116	48.5	127	48.4	142	48.4	155	48.5	166	48.7	177	48.9	196	49.3	219	49.8
	180	126	53.3	140	53.7	155	54.2	173	54.9	190	55.6	204	56.1	217	56.7	239	57.8	265	59.1
	210	140	61.5	156	61.9	173	62.2	193	62.6	212	63.0	227	63.2	241	63.5	266	64.0	294	64.7
	230	157	65.4	175	66.1	195	66.8	219	67.8	244	68.7	264	69.4	285	70.2	322	71.6	372	73.5
250	172	74.2	192	75.3	213	76.3	240	77.7	266	79.0	287	80.1	310	81.2	350	83.1	402	85.6	
40	080	56.2	26.5	61.7	26.5	67.7	26.6	75.9	26.8	83.2	27.1	88.9	27.3	94.9	27.6	105	28.1	118	28.8
	100	72.1	32.2	79.7	32.6	87.7	33.0	98.5	33.5	108	34.0	115	34.4	123	34.8	136	35.5	152	36.3
	130	94	42.5	104	42.8	115	43.2	129	43.9	141	44.6	151	45.1	161	45.7	178	46.8	200	48.1
	150	105	53.7	116	53.5	127	53.3	142	53.3	155	53.3	165	53.4	176	53.6	194	54.0	217	54.5
	180	125	58.8	139	59.2	153	59.7	172	60.4	189	61.1	201	61.7	214	62.3	236	63.4	261	64.8
	210	140	67.7	156	68.2	172	68.6	193	69.1	212	69.5	226	69.7	240	70.0	264	70.5	291	71.1
	230	156	71.9	174	72.7	193	73.5	218	74.6	242	75.6	261	76.4	281	77.2	317	78.6	364	80.6
250	171	81.5	190	82.7	211	83.8	239	85.2	264	86.7	284	87.9	306	89.0	344	91.1	393	93.7	
45	080					66.9	29.4	74.7	29.5	82.3	29.8	87.7	30.0	93.4	30.3	103	30.6	116	30.8
	100					86.8	36.6	97.1	37.2	107	37.7	114	38.1	121	38.5	134	39.3	149	40.2
	130					113	47.9	127	48.4	140	49.1	149	49.6	159	50.2	175	51.2	196	52.6
	150					127	58.9	141	58.7	155	58.7	165	58.8	175	58.9	193	59.3	215	59.8
	180					151	65.9	169	66.6	187	67.4	199	68.0	211	68.6	232	69.8	256	71.2
	210					171	75.8	192	76.3	212	76.8	225	77.0	239	77.3	262	77.8	289	78.3
	230					191	81.1	215	82.3	240	83.4	258	84.2	277	85.0	311	86.5	355	88.5
250					209	92.2	235	93.8	262	95.4	281	96.6	301	97.8	337	100	384	103	
50	080					73.4	32.6	81.4	32.9	86.4	33.1	91.7	33.4	101	33.9	113	34.7		
	100					95.7	41.3	106	41.9	113	42.3	120	42.7	132	43.5	146	44.4		
	130					125	53.7	138	54.3	147	54.8	156	55.3	172	56.3	191	57.7		
	150					140	64.9	155	64.8	165	64.9	175	65.0	192	65.3	213	65.8		
	180					167	73.7	185	74.4	196	75.1	208	75.7	228	76.9	251	78.3		
	210					191	84.5	212	85.0	225	85.3	238	85.6	260	86.0	286	86.5		
	230					212	90.9	237	92.1	254	93.0	272	93.8	304	95.4	346	97		
250					232	103	259	105	277	106	295	108	329	110	373	113			

**NOTES**

- Heating capacity (CAP)  
Capacity is according to Eurovent rating standard 6/C/003-2006 and valid for heated water range Dt = 3 - 8°C
- Power input (kW)  
Power input is total input according to Eurovent rating standard 6/C/003-2006: Compressor + fans + control circuit
- HC tabulated does not include capacity drop during frosting period and defrost.  
The integrated Heating Capacity takes into consideration the capacity drop during frosting period and defrosting operation.

$$(HC)_{integrated} = (HC) * (\text{Integrated correction factor during frosting period})$$

Integrated heating capacity means the heating capacity during one cycle (between defrosting period and defrosting period), which is integrated and converted to heating capacity per hour.

Integrated correction factor

Tamb (°C) RH 85%	-10	-7	-4	0	4	7
Correction factor	0.96	0.95	0.92	0.87	0.90	1.00

- In case the surface of the heat exchanger is covered with snow, heating capacity drops temporarily although it differs with outdoor temperature (°CDB), relative humidity (RH) and frosting volume.

**SYMBOLS**

- HC : Heating capacity (kW)
- PI : Power input (kW)
- LWE : Leaving Water Condenser temperature (°C)
- Tamb : Ambient temperature (°C)

Integrated heating capacity graph:

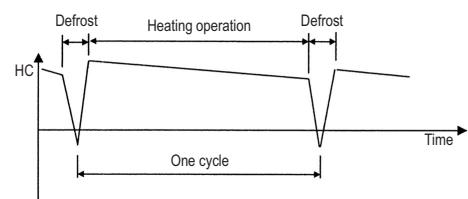



# 4 Capacity tables

## 4 - 3 Capacity Correction Factor

Required glycol concentration

Type	Concentration (wt%)	0	10	20	30	40
Ethylene glycol	Freezing point °C	0	-4	-9	-16	-23
	Minimum LWE °C	4	2	0	-5	-11
Propylene glycol	Freezing point °C	0	-3	-7	-13	-22
	Minimum LWE °C	4	3	-2	-4	-10

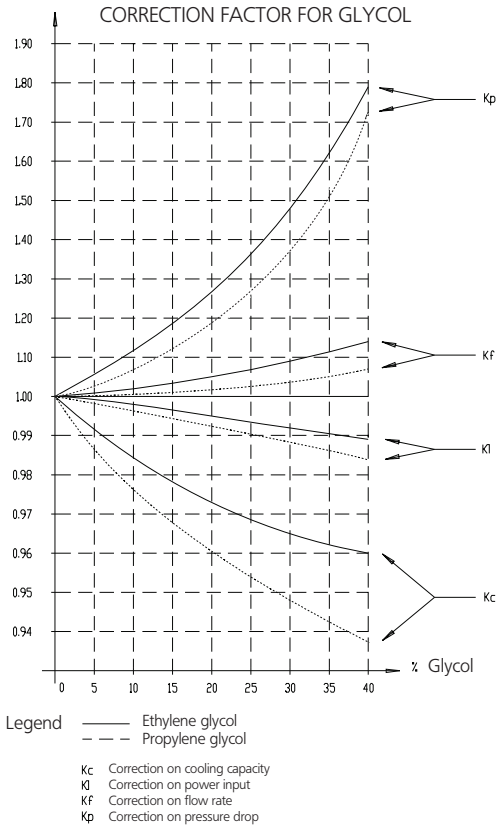

# 5 Dimensional drawings

## 5 - 1 Dimensional Drawings

2  
5

### EWYQ080-100DAYN(N)

- |  |                         |
|--|-------------------------|
| 01 Evaporator                                    | 21 Transport beam       |
| 02 Condensor                                     | 22 Flowswitch           |
| 03 Compressor                                    | 23 Fan                  |
| 04 Expansion valve + sight glass                 | 24 Safety valve         |
| 05 Discharge stopvalve (Optional)                | 25 High pressure sensor |
| 06 Suction stopvalve (Optional)                  | 26 Low pressure sensor  |
| 07 Liquid stopvalve (Optional)                   | 27 High pressure switch |
| 08 Chilled water IN (Victaulic coupling)         | 28 Oil sight glass      |
| 09 Chilled water OUT (Victaulic coupling)        | 29 Waterfilter          |
| 10 Water drain evaporator                        | 30 Frame                |
| 11 Air purge                                     | 31 4-way valve          |
| 12 Leaving water temperature sensor              | 32 Liquid receiver      |
| 13 Entering water temperature sensor             |                         |
| 14 Ambient temperature sensor                    |                         |
| 15 Drier + charge valve                          |                         |
| 16 Power supply intake                           |                         |
| 17 Switchbox                                     |                         |
| 18 Digital display controller (Inside switchbox) |                         |
| 19 Field wiring intake                           |                         |
| 20 Main isolator switch                          |                         |

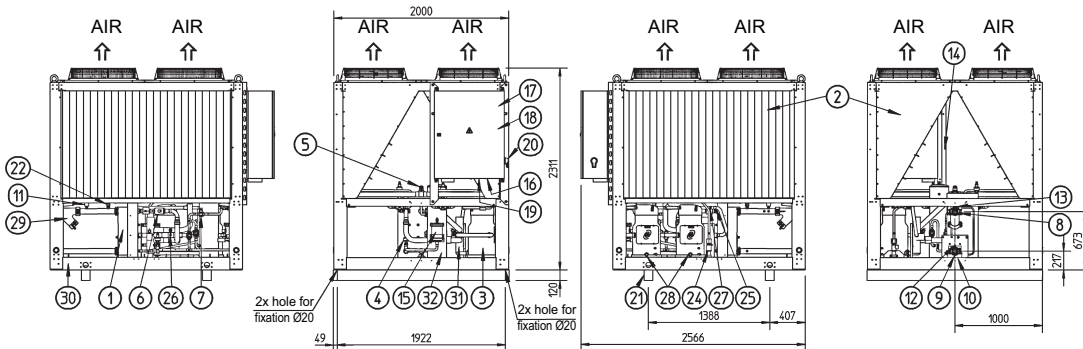
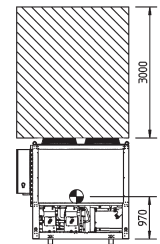
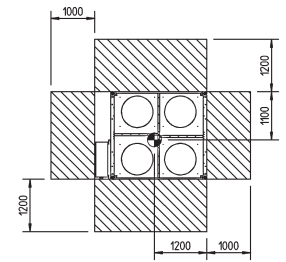
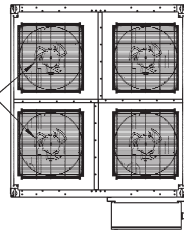

3TW57654-2

### EWYQ80-100DAYN(P-B)

- |  |                                      |
|--|--------------------------------------|
| 01 Evaporator                                    | 21 Transport beam                    |
| 02 Condensator                                   | 22 Flowswitch                        |
| 03 Compressor                                    | 23 Fan                               |
| 04 Expansion valve + sight glass                 | 24 Safety valve                      |
| 05 Discharge stopvalve (Optional)                | 25 High pressure sensor              |
| 06 Suction stopvalve (Optional)                  | 26 Low pressure sensor               |
| 07 Liquid stopvalve (Optional)                   | 27 High pressure switch              |
| 08 Chilled water IN (Victaulic coupling)         | 28 Oil sight glass                   |
| 09 Chilled water OUT (Victaulic coupling)        | 29 Waterfilter                       |
| 10 Water drain evaporator                        | 30 Frame                             |
| 11 Air purge                                     | 31 4-way valve                       |
| 12 Leaving water temperature sensor              | 32 Liquid receiver                   |
| 13 Entering water temperature sensor             | 33 Pump (Optional)                   |
| 14 Ambient temperature sensor                    | 34 Buffertank (Optional)             |
| 15 Drier + charge valve                          | 35 Expansion vessel (Optional)       |
| 16 Power supply intake                           | 36 Water stopvalve (Optional)        |
| 17 Switchbox                                     | 37 Buffertank drain valve (Optional) |
| 18 Digital display controller (Inside switchbox) | 38 Regulating valve (Optional)       |
| 19 Field wiring intake                           | 39 Water safety valve (Optional)     |
| 20 Main isolator switch                          | 40 Pressure gauge (Optional)         |

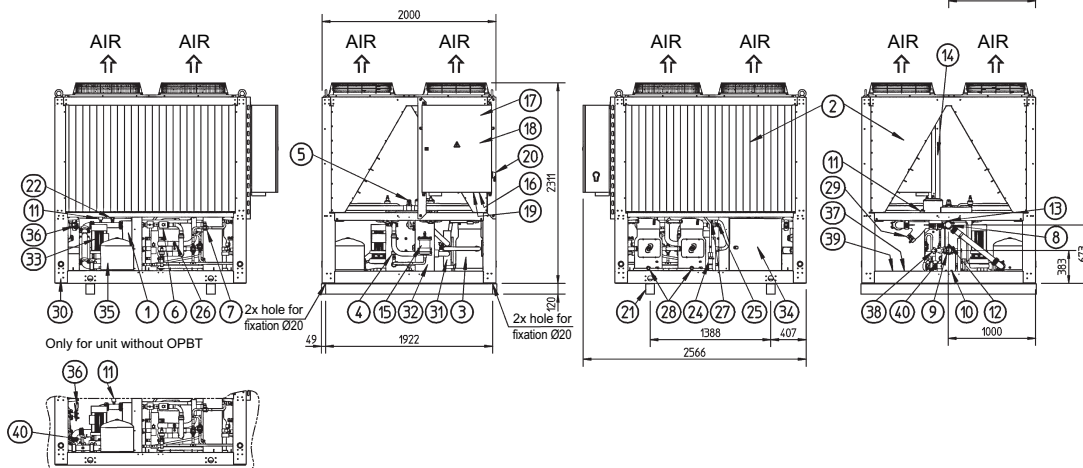
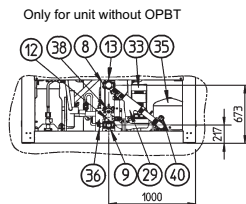
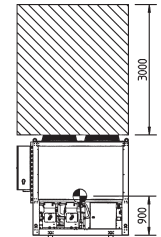
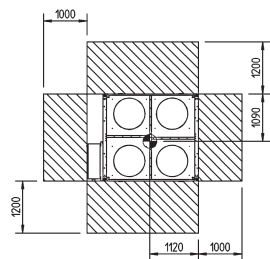
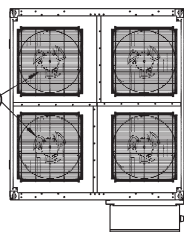

3TW57654-1

# 5 Dimensional drawings

## 5 - 1 Dimensional Drawings

### EWYQ130-150DAYN(N)

- 01 Evaporator
- 02 Condensor
- 03 Compressor
- 04 Expansion valve + sight glass
- 05 Discharge stopvalve (Optional)
- 06 Suction stopvalve (Optional)
- 07 Liquid stopvalve (Optional)
- 08 Chilled water IN (Victaulic coupling)
- 09 Chilled water OUT (Victaulic coupling)
- 10 Water drain evaporator
- 11 Air purge
- 12 Leaving water temperature sensor
- 13 Entering water temperature sensor
- 14 Ambient temperature sensor
- 15 Drier + charge valve
- 16 Power supply intake
- 17 Switchbox
- 18 Digital display controller (Inside switchbox)
- 19 Field wiring intake
- 20 Main isolator switch

- 21 Transport beam
- 22 Flowswitch
- 23 Fan
- 24 Safety valve
- 25 High pressure sensor
- 26 Low pressure sensor
- 27 High pressure switch
- 28 Oil sight glass
- 29 Waterfilter
- 30 Frame
- 31 4-way valve
- 32 Liquid receiver

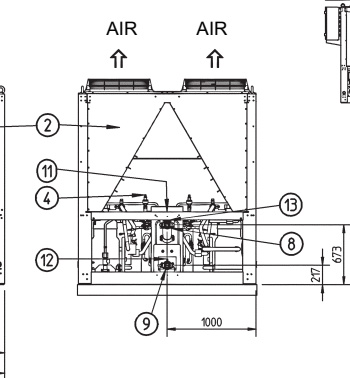
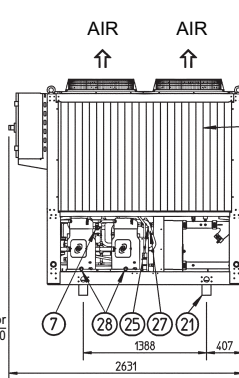
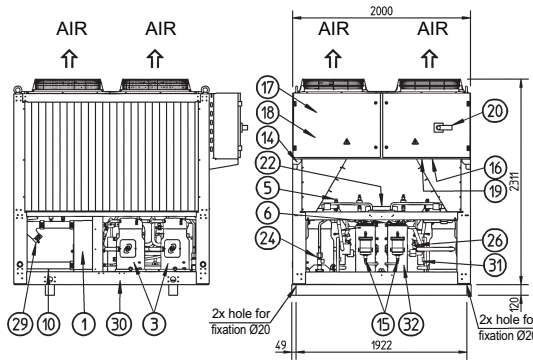
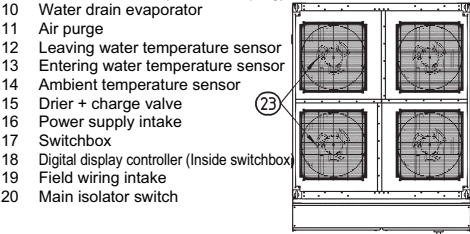

**Legend**

- Required space around the unit for service and air intake
- Center of gravity

3TW57674-2A

### EWYQ130-150DAYN(P-B)

- 01 Evaporator
- 02 Condensor
- 03 Compressor
- 04 Expansion valve + sight glass
- 05 Discharge stopvalve (Optional)
- 06 Suction stopvalve (Optional)
- 07 Liquid stopvalve (Optional)
- 08 Chilled water IN (Victaulic coupling)
- 09 Chilled water OUT (Victaulic coupling)
- 10 Water drain evaporator
- 11 Air purge
- 12 Leaving water temperature sensor
- 13 Entering water temperature sensor
- 14 Ambient temperature sensor
- 15 Drier + charge valve
- 16 Power supply intake
- 17 Switchbox
- 18 Digital display controller (Inside switchbox)
- 19 Field wiring intake
- 20 Main isolator switch

- 21 Transport beam
- 22 Flowswitch
- 23 Fan
- 24 Safety valve
- 25 High pressure sensor
- 26 Low pressure sensor
- 27 High pressure switch
- 28 Oil sight glass
- 29 Waterfilter
- 30 Frame
- 31 4-way valve
- 32 Liquid receiver
- 33 Pump (Optional)
- 34 Buffertank (Optional)
- 35 Expansion vessel (Optional)
- 36 Water stopvalve (Optional)
- 37 Buffertank drain valve (Optional)
- 38 Regulating valve (Optional)
- 39 Water safety valve (Optional)
- 40 Pressure gauge (Optional)

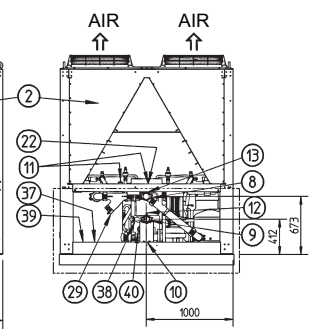
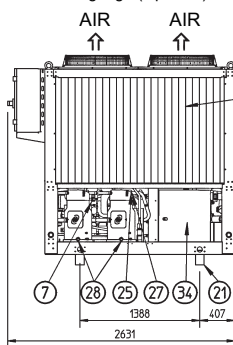
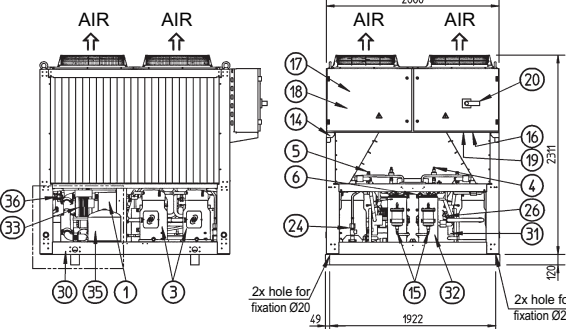
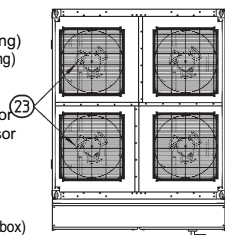

**Legend**

- Required space around the unit for service and air intake
- Center of gravity

3TW57674-1A

# 5 Dimensional drawings

## 5 - 1 Dimensional Drawings

2  
5

### EWYQ180-210DAYN(N)

- |  |                           |
|--|---------------------------|
| 01 Evaporator                                    | 21 Transport beam         |
| 02 Condensor                                     | 22 Flowswitch             |
| 03 Compressor                                    | 23 Fan                    |
| 04 Expansion valve + sight glass                 | 24 Safety valve           |
| 05 Discharge stopvalve (Optional)                | 25 High pressure sensor   |
| 06 Suction stopvalve (Optional)                  | 26 Low pressure sensor    |
| 07 Liquid stopvalve (Optional)                   | 27 High pressure switch   |
| 08 Chilled water IN (Victaulic coupling)         | 28 Oil sight glass        |
| 09 Chilled water OUT (Victaulic coupling)        | 29 Waterfilter            |
| 10 Water drain evaporator                        | 30 Frame                  |
| 11 Air purge                                     | 31 4-way valve (Optional) |
| 12 Leaving water temperature sensor              | 32 Liquid receiver        |
| 13 Entering water temperature sensor             |                           |
| 14 Ambient temperature sensor                    |                           |
| 15 Drier + charge valve                          |                           |
| 16 Power supply intake                           |                           |
| 17 Switchbox                                     |                           |
| 18 Digital display controller (Inside switchbox) |                           |
| 19 Field wiring intake                           |                           |
| 20 Main isolator switch                          |                           |

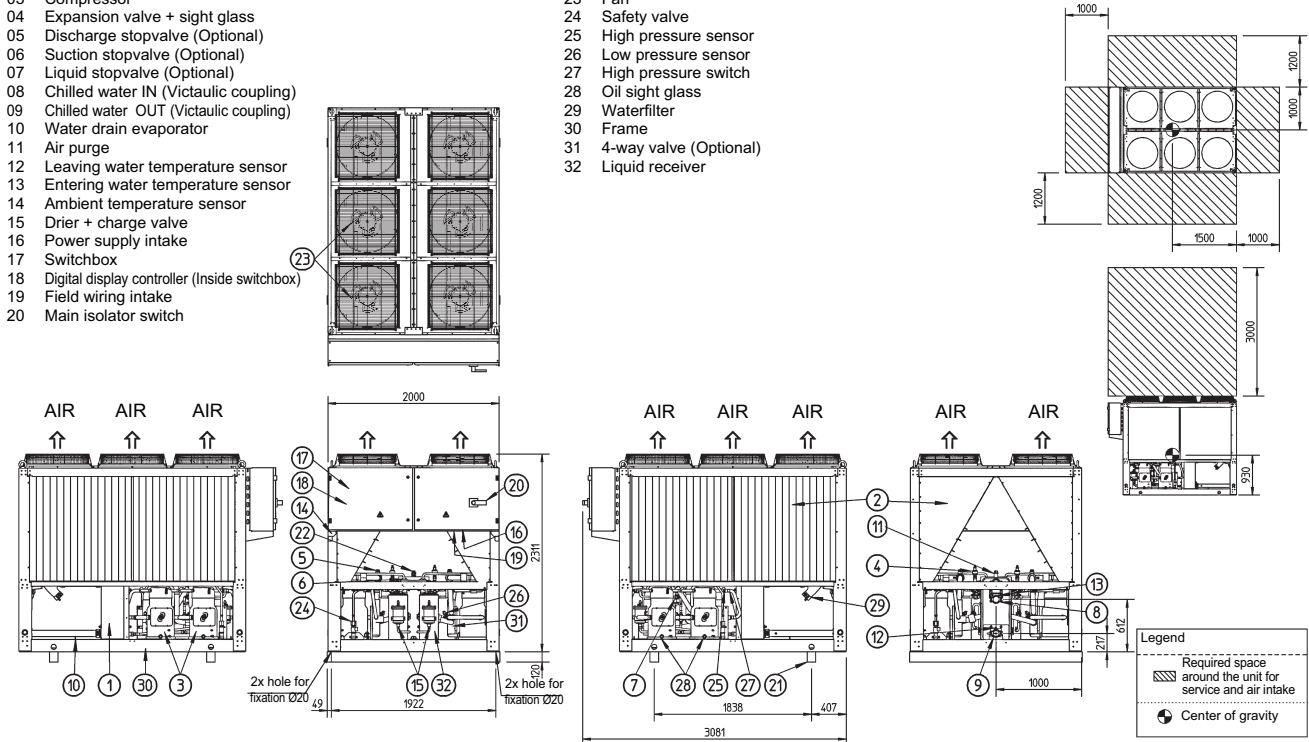

3TW57694-2A

### EWYQ180-210DAYN(P-B)

- |  |                                      |
|--|--------------------------------------|
| 01 Evaporator                                    | 21 Transport beam                    |
| 02 Condensor                                     | 22 Flowswitch                        |
| 03 Compressor                                    | 23 Fan                               |
| 04 Expansion valve + sight glass                 | 24 Safety valve                      |
| 05 Discharge stopvalve (Optional)                | 25 High pressure sensor              |
| 06 Suction stopvalve (Optional)                  | 26 Low pressure sensor               |
| 07 Liquid stopvalve (Optional)                   | 27 High pressure switch              |
| 08 Chilled water IN (Victaulic coupling)         | 28 Oil sight glass                   |
| 09 Chilled water OUT (Victaulic coupling)        | 29 Waterfilter                       |
| 10 Water drain evaporator                        | 30 Frame                             |
| 11 Air purge                                     | 31 4-way valve                       |
| 12 Leaving water temperature sensor              | 32 Liquid receiver                   |
| 13 Entering water temperature sensor             | 33 Pump (Optional)                   |
| 14 Ambient temperature sensor                    | 34 Buffertank (Optional)             |
| 15 Drier + charge valve                          | 35 Expansion vessel (Optional)       |
| 16 Power supply intake                           | 36 Water stopvalve (Optional)        |
| 17 Switchbox                                     | 37 Buffertank drain valve (Optional) |
| 18 Digital display controller (Inside switchbox) | 38 Regulating valve (Optional)       |
| 19 Field wiring intake                           | 39 Water safety valve (Optional)     |
| 20 Main isolator switch                          | 40 Pressure gauge (Optional)         |

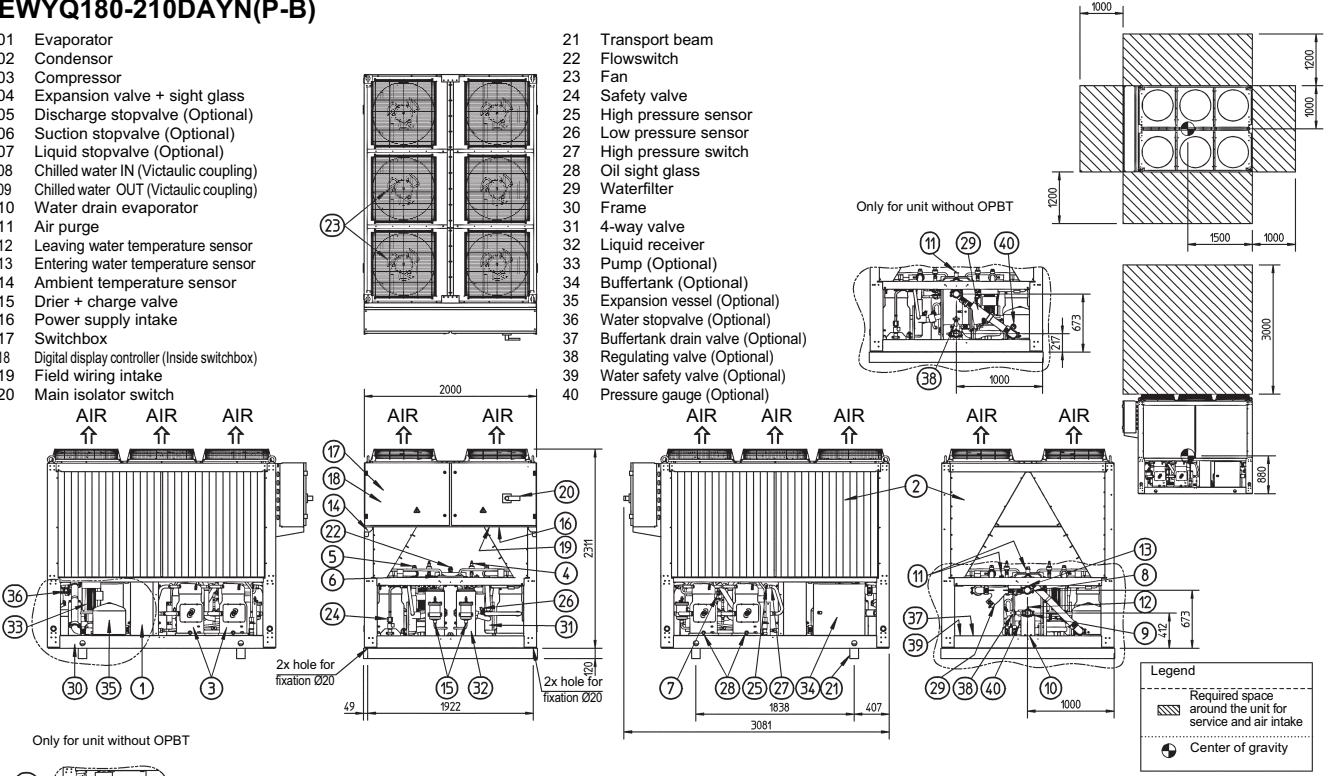

3TW57694-1A



# 5 Dimensional drawings

## 5 - 1 Dimensional Drawings

**EWYQ230-250DAYN(N)**

01 Evaporator	21 Transport beam
02 Condenser	22 Flowswitch
03 Compressor	23 Fan
04 Expansion valve + sight glass	24 Safety valve
05 Discharge stopvalve (Optional)	25 High pressure sensor
06 Suction stopvalve (Optional)	26 Low pressure sensor
07 Liquid stopvalve (Optional)	27 High pressure switch
08 Chilled water IN (Victaulic coupling)	28 Oil sight glass
09 Chilled water OUT (Victaulic coupling)	29 Waterfilter
10 Water drain evaporator	30 Frame
11 Air purge	31 4-way valve
12 Leaving water temperature sensor	32 Liquid receiver
13 Entering water temperature sensor	
14 Ambient sensor	
15 Drier + charge valve	
16 Power supply intake	
17 Switchbox	
18 Digital display controller (Inside switchbox)	
19 Field wiring intake	
20 Main isolator switch	

**Legend**

- Required space around the unit for service and air intake
- Center of gravity

3TW57714-2

**EWYQ230-250DAYN(P-B)**

01 Evaporator	21 Transport beam
02 Condenser	22 Flowswitch
03 Compressor	23 Fan
04 Expansion valve + sight glass	24 Safety valve
05 Discharge stopvalve (Optional)	25 High pressure sensor
06 Suction stopvalve (Optional)	26 Low pressure sensor
07 Liquid stopvalve (Optional)	27 High pressure switch
08 Chilled water IN (Victaulic coupling)	28 Oil sight glass
09 Chilled water OUT (Victaulic coupling)	29 Waterfilter
10 Water drain evaporator	30 Frame
11 Air purge	31 4-way valve
12 Leaving water temperature sensor	32 Liquid receiver
13 Entering water temperature sensor	33 Pump (Optional)
14 Ambient temperature sensor	34 Buffertank (Optional)
15 Drier + charge valve	35 Expansion vessel (Optional)
16 Power supply intake	36 Water stopvalve (Optional)
17 Switchbox	37 Buffertank drain valve (Optional)
18 Digital display controller (Inside switchbox)	38 Regulating valve (Optional)
19 Field wiring intake	39 Water safety valve (Optional)
20 Main isolator switch	40 Pressure gauge (Optional)

**Legend**

- Required space around the unit for service and air intake
- Center of gravity

Only for unit without OPBT

3TW57714-1

## 6 Piping diagrams

### 6 - 1 Piping Diagrams

EWAQ-EWYQ-DAYN(N-P-B)(water piping diagram)

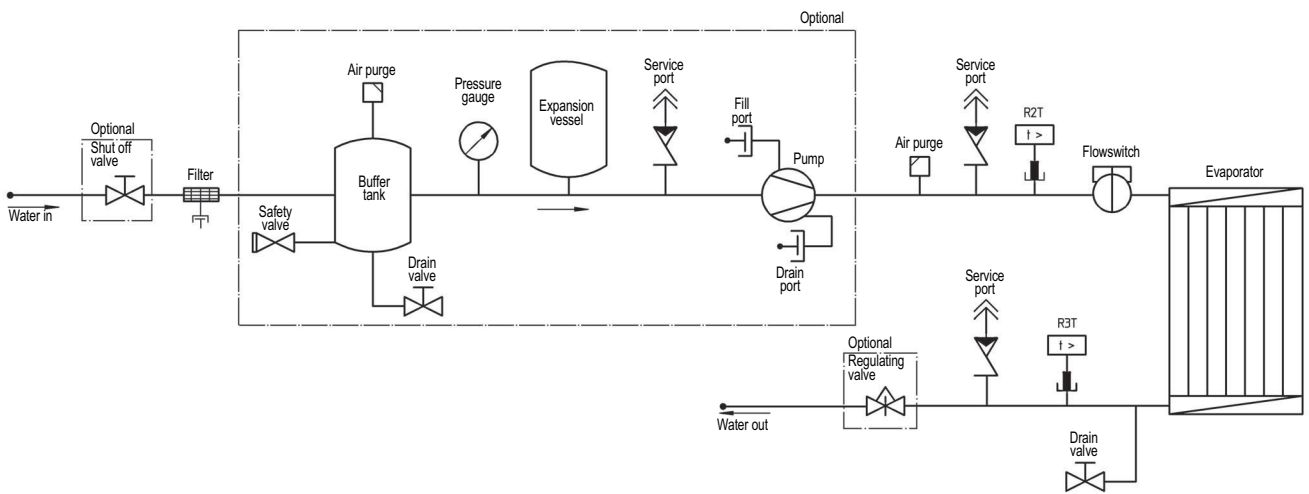

- ⏪ : Check valve
- ⏩ : Flare Conn.
- ⏪ : Screw conn.

- ⏪ : Flange conn.
- ⏩ : Pinched pipe
- : Spinned pipe

3TW57575-2A

# 6 Piping diagrams

## 6 - 1 Piping Diagrams

EWYQ080-100DAYN (N-P-B)(piping diagram)

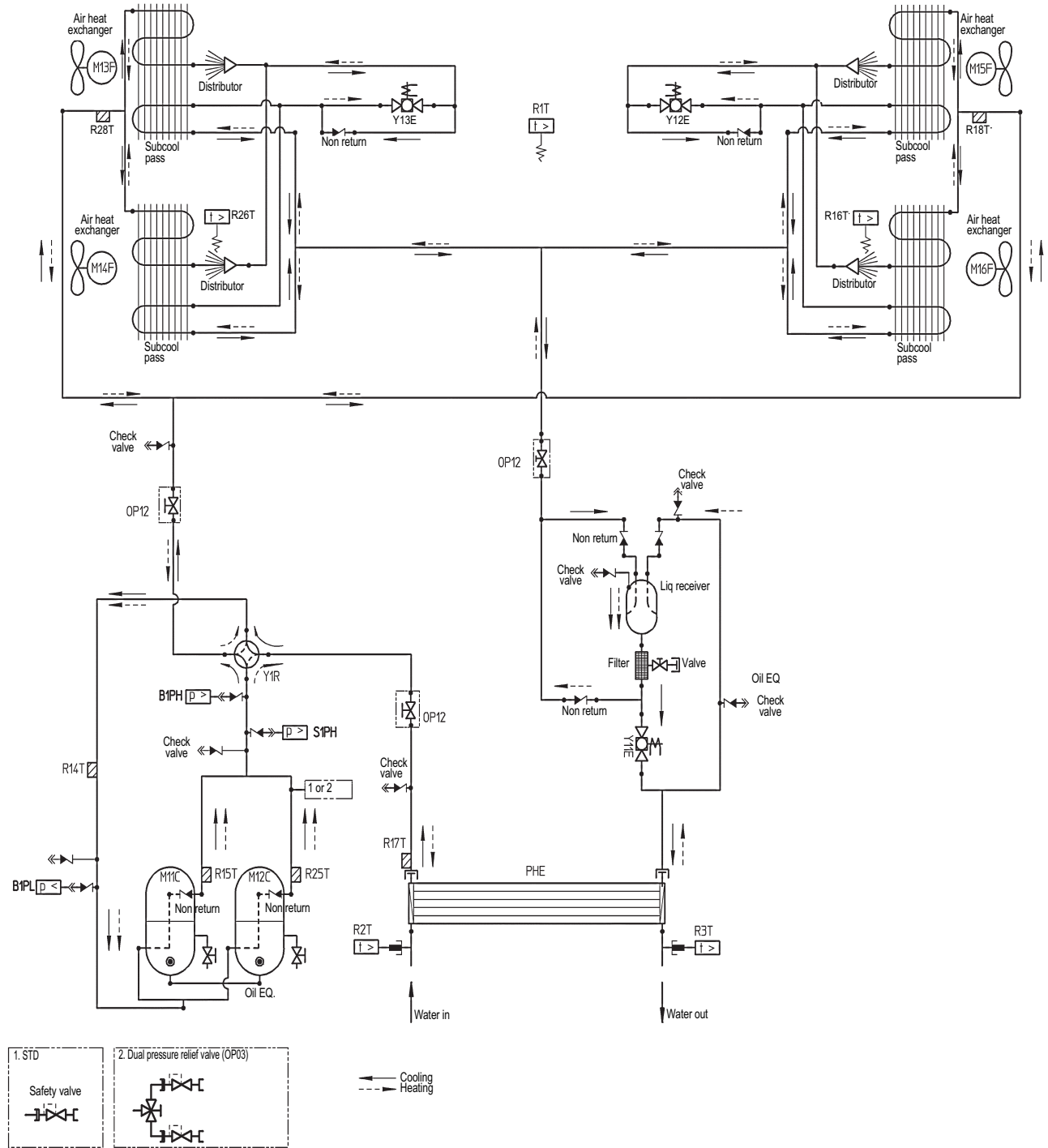

Brand	Designation	R15T, R25T	Designation
M11-12C	Compressor motors	B1PH	High pressure sensor
M13-16F	Fan motors	B1PL	Low pressure sensor
R14T	Suction temperature sensor	Y11E	Electronic Expansion valve cooling
R17T	Refrigerant piping temperature sensor	Y12E, Y22E	Electronic expansion valve heating coil 1
R18T, R28T	Heating suction piping temperature sensor	R1T	Ambient temperature sensor
R16T, R26T	Coil temperature sensor	R2T	Evaporator inlet water temperature sensor
S1PH	High pressure switch	R3T	Evaporator outlet water temperature sensor
Y1R	Reverse valve		

- ←| : Check valve
- ←| : Flare Conn.
- | : Screw conn.
- | : Flange conn.
- | : Pinched pipe
- | : Spinned pipe

3TW57655-1C



# 6 Piping diagrams

## 6 - 1 Piping Diagrams

EWYQ130-210DAYN (N-P-B)(piping diagram)

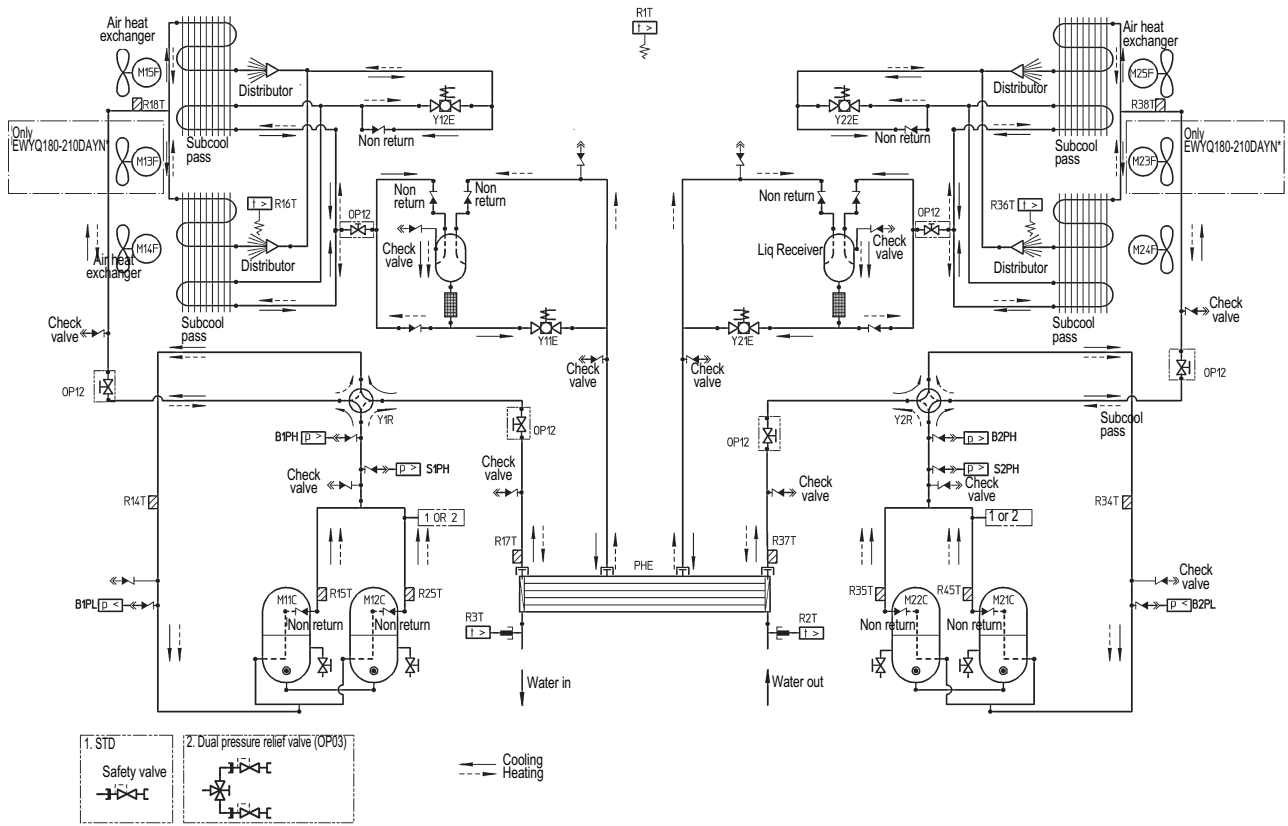

Merk	Benaming	R36T	Coil temperature sensor circuit 2
M11-12C	Compressor motors circuit 1	R37T	Refrigerant piping temperature sensor circuit 2
M13-15F	Fan motors circuit 1	R38T	Heating suction temp sensor circuit 2
R14T	Suction temperature sensor circuit 1	S2PH	High pressure switch circuit 2
R16T	Coil temperature sensor circuit 1	Y2R	Reverse valve circuit 2
R17T	Refrigerant piping temperature sensor circuit 1	R35T, R45T	Discharge temperature sensor circuit 2
R18T	Heating suction temp sensor circuit 1	B2PH	High pressure sensor circuit 2
S1PH	High pressure sensor circuit 1	B2PL	Low pressure sensor circuit 2
B1PL	Low pressure sensor circuit 1	Y21E	Electronic Expansion valve cooling circuit 2
Y11E	Electronic Expansion valve cooling circuit 1	Y22E	Electronic expansion valve heating circuit 2
Y12E	Electronic expansion valve heating circuit 1	R1T	Ambient temperature sensor
M21-22C	Compressor motors circuit 2	R2T	Evaporator inlet water temperature sensor
M23-25F	Fan motors circuit 2	R3T	Evaporator outlet water temperature sensor
R34T	Suction temperature sensor circuit 2		

- ↔ : Check valve
- ↔ : Flare Conn.
- |— : Screw conn.
- |— : Flange conn.
- ⊗ : Pinched pipe
- : Spinned pipe

2TW57675-1A

2  
6

# 6 Piping diagrams

## 6 - 1 Piping Diagrams

EWYQ230-250DAYN(N-P-B) (piping diagram)

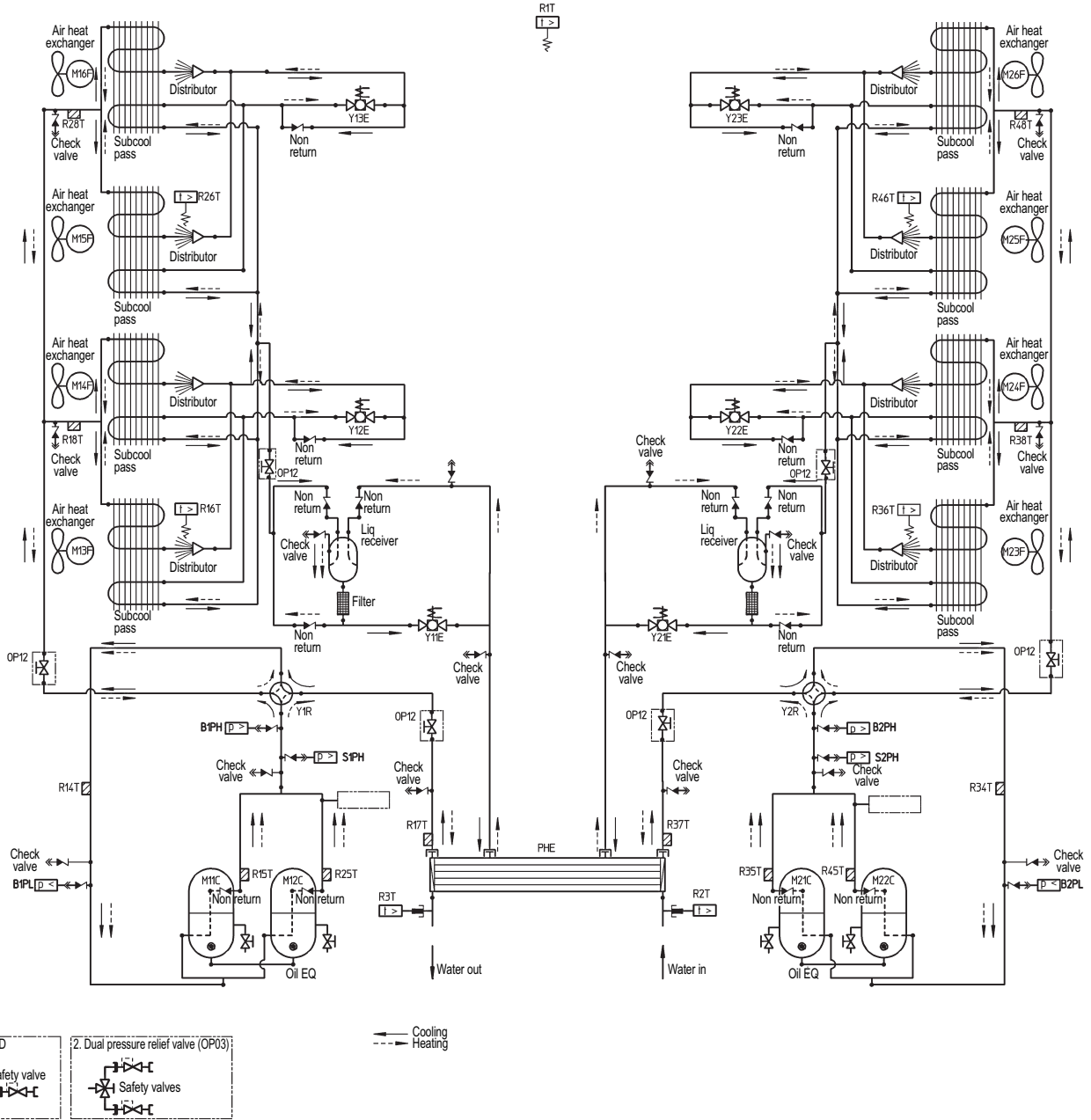

MERK	BENAMING	M23-26F	Fan motors circuit 2
M11-12C	Compressor motors circuit 1	R34T	Suction temperature sensor circuit 2
M13-16F	Fan motors circuit 1	R36T, R46T	Coil temperature sensor circuit 2
R14T	Suction temperature sensor circuit 1	R37T	Refrigerant piping temperature sensor circuit 2
R16T, R26T	Coil temperature sensor circuit 1	S2PH	High pressure switch circuit 2
R17T	Refrigerant piping temperature sensor circuit 1	Y2R	Reverse valve circuit 2
S1PH	High pressure switch circuit 1	R35T, R45T	Discharge temperature sensor circuit 2
Y1R	Reverse valve circuit 1	B2PH	High pressure sensor circuit 2
R15T, R25T	Discharge temperature sensor circuit 1	B2PL	Low pressure sensor circuit 2
B1PH	High pressure sensor circuit 1	Y21E	Electronic expansion valve cooling circuit 2
B1PL	Low pressure sensor circuit 1	R38T, R48T	Heating suction temperature sensor circuit 2
Y11E	Electronic expansion valve cooling circuit 1	Y22E, Y23E	Electronic expansion valve heating circuit 2
R18T, R28T	Heating suction temperature sensor circuit 1	R1T	Ambient temperature sensor
Y12E, Y13E	Electronic expansion valve heating circuit 1	R2T	Evaporator inlet water temperature sensor
M21-22C	Compressor motors circuit 2	R3T	Evaporator outlet water temperature sensor



2TW57715-1

# 7 External connection diagrams

## 7 - 1 External Connection Diagrams

2  
7

0	1	2	3	4	5	6	7	8	9																																																																													
<b>LEGEND</b>					<p>(1) Fieldwiring: Main power connection</p>																																																																																	
<p>Translation of this legend can be found in the installation manual.</p> <table border="1" style="width:100%; border-collapse: collapse;"> <tr> <td colspan="2" style="text-align: center;">Not included with standard unit</td> <td colspan="2"></td> </tr> <tr> <td style="text-align: center;">Obligatory</td> <td style="text-align: center;">#</td> <td style="text-align: center;">Not possible as option</td> <td style="text-align: center;">##</td> </tr> <tr> <td style="text-align: center;">Not obligatory</td> <td style="text-align: center;">*</td> <td style="text-align: center;">Possible as option</td> <td style="text-align: center;">**</td> </tr> </table>										Not included with standard unit				Obligatory	#	Not possible as option	##	Not obligatory	*	Possible as option	**																																																																	
Not included with standard unit																																																																																						
Obligatory	#	Not possible as option	##																																																																																			
Not obligatory	*	Possible as option	**																																																																																			
<p>Part number      Description</p> <table border="1" style="width:100%; border-collapse: collapse;"> <tr><td>A02P</td><td>**</td><td>Communication PCB (EKACPG)</td></tr> <tr><td>A4P</td><td>**</td><td>PCB wired remote control</td></tr> <tr><td>A5P</td><td>**</td><td>PCB wired remote control (EKRUPG)</td></tr> <tr><td>E5H</td><td>*</td><td>fieldheater</td></tr> <tr><td>F1, F2, F3</td><td>#</td><td>main fuses</td></tr> <tr><td>F4, F5</td><td>#</td><td>fuses for heaters</td></tr> <tr><td>H11, H2, H2P</td><td>*</td><td>indication lamp: operation compressor</td></tr> <tr><td>H1P</td><td>*</td><td>indication lamp: alarm signal (default NO)</td></tr> <tr><td>H2, H3, H4, H5</td><td>*</td><td>indication lamp for changeable digital outputs</td></tr> <tr><td>K1P</td><td>##</td><td>pump contactor (Only OPSP/OPHP/OPSC/OPTP/OPTC)</td></tr> <tr><td>K2P</td><td>##</td><td>pump contactor (Only for OPTP/OPTC)</td></tr> <tr><td>K1S</td><td>*</td><td>overcurrent relay pump (P/B unit or OPSC)</td></tr> <tr><td>M1P</td><td>*</td><td>pump motor 1 (Only OPSP/OPHP/OPSC/OPTP/OPTC)</td></tr> <tr><td>M2P</td><td>*</td><td>pump motor 2 (Only for OPTP/OPTC)</td></tr> <tr><td>R8T</td><td>*</td><td>temperature sensor for changeable analog input</td></tr> <tr><td>S1M</td><td>*</td><td>main isolator switch</td></tr> <tr><td>S1, 2, 3, 4, 5S</td><td>*</td><td>switch for changeable digital input</td></tr> <tr><td>S2M</td><td>#</td><td>heateptape isolator switch</td></tr> <tr><td>V2C</td><td>**</td><td>terrace core (EKACPG)</td></tr> </table>					A02P	**	Communication PCB (EKACPG)	A4P	**	PCB wired remote control	A5P	**	PCB wired remote control (EKRUPG)	E5H	*	fieldheater	F1, F2, F3	#	main fuses	F4, F5	#	fuses for heaters	H11, H2, H2P	*	indication lamp: operation compressor	H1P	*	indication lamp: alarm signal (default NO)	H2, H3, H4, H5	*	indication lamp for changeable digital outputs	K1P	##	pump contactor (Only OPSP/OPHP/OPSC/OPTP/OPTC)	K2P	##	pump contactor (Only for OPTP/OPTC)	K1S	*	overcurrent relay pump (P/B unit or OPSC)	M1P	*	pump motor 1 (Only OPSP/OPHP/OPSC/OPTP/OPTC)	M2P	*	pump motor 2 (Only for OPTP/OPTC)	R8T	*	temperature sensor for changeable analog input	S1M	*	main isolator switch	S1, 2, 3, 4, 5S	*	switch for changeable digital input	S2M	#	heateptape isolator switch	V2C	**	terrace core (EKACPG)	<p>Options (factory installed)</p> <table border="1" style="width:100%; border-collapse: collapse;"> <tr><td>OPSP</td><td>=Single pump</td></tr> <tr><td>OPHP</td><td>=Twin pump</td></tr> <tr><td>OPSC</td><td>=Single pump contactor</td></tr> <tr><td>OPTC</td><td>=Twin pump contactor</td></tr> <tr><td>OPHP</td><td>=Hi ESP pump</td></tr> <tr><td>OPIF</td><td>=Inverter fans</td></tr> </table> <p>Options (user installed)</p> <table border="1" style="width:100%; border-collapse: collapse;"> <tr><td>EKACPG</td><td>=Address card including</td></tr> <tr><td>RS485</td><td>(integrated modbus)</td></tr> <tr><td>F1, F2 (DCIN/DBACS connection)</td><td></td></tr> <tr><td>EKRUPG</td><td>=Remote user interface</td></tr> </table> <p>(N-Model) =unit with no options included Ch. =Changeable</p>					OPSP	=Single pump	OPHP	=Twin pump	OPSC	=Single pump contactor	OPTC	=Twin pump contactor	OPHP	=Hi ESP pump	OPIF	=Inverter fans	EKACPG	=Address card including	RS485	(integrated modbus)	F1, F2 (DCIN/DBACS connection)		EKRUPG	=Remote user interface
A02P	**	Communication PCB (EKACPG)																																																																																				
A4P	**	PCB wired remote control																																																																																				
A5P	**	PCB wired remote control (EKRUPG)																																																																																				
E5H	*	fieldheater																																																																																				
F1, F2, F3	#	main fuses																																																																																				
F4, F5	#	fuses for heaters																																																																																				
H11, H2, H2P	*	indication lamp: operation compressor																																																																																				
H1P	*	indication lamp: alarm signal (default NO)																																																																																				
H2, H3, H4, H5	*	indication lamp for changeable digital outputs																																																																																				
K1P	##	pump contactor (Only OPSP/OPHP/OPSC/OPTP/OPTC)																																																																																				
K2P	##	pump contactor (Only for OPTP/OPTC)																																																																																				
K1S	*	overcurrent relay pump (P/B unit or OPSC)																																																																																				
M1P	*	pump motor 1 (Only OPSP/OPHP/OPSC/OPTP/OPTC)																																																																																				
M2P	*	pump motor 2 (Only for OPTP/OPTC)																																																																																				
R8T	*	temperature sensor for changeable analog input																																																																																				
S1M	*	main isolator switch																																																																																				
S1, 2, 3, 4, 5S	*	switch for changeable digital input																																																																																				
S2M	#	heateptape isolator switch																																																																																				
V2C	**	terrace core (EKACPG)																																																																																				
OPSP	=Single pump																																																																																					
OPHP	=Twin pump																																																																																					
OPSC	=Single pump contactor																																																																																					
OPTC	=Twin pump contactor																																																																																					
OPHP	=Hi ESP pump																																																																																					
OPIF	=Inverter fans																																																																																					
EKACPG	=Address card including																																																																																					
RS485	(integrated modbus)																																																																																					
F1, F2 (DCIN/DBACS connection)																																																																																						
EKRUPG	=Remote user interface																																																																																					
<b>Changeable I/O possible functions</b>					<p>(1) Fieldwiring: communication wiring</p>																																																																																	
<p>Refer to the installation manual for instructions how to configure changeable I/O</p> <table border="1" style="width:100%; border-collapse: collapse;"> <tr> <td style="width:50%;"> <p>Changeable digital input (4 available)</p> <ul style="list-style-type: none"> <li>None</li> <li>Status</li> <li>Dual setpoint</li> <li>Remote on-off</li> <li>Capacity limitation 25%, 50%, 75% or setting</li> <li>Low noise (only for OPIF)</li> <li>Free cooling signal</li> <li>Fan forced on</li> </ul> </td> <td style="width:50%;"> <p>Changeable analog output (1 available)</p> <ul style="list-style-type: none"> <li>None</li> <li>Status (mA, V, NTC, DI)</li> <li>Unit Capacity (mA, V)</li> <li>Details of types</li> <li>Type mA: 0, 20mA/4, 20mA</li> <li>Type V: 0-1V/0-5V/0-10V</li> </ul> </td> </tr> <tr> <td> <p>Changeable digital output (6 or 5 available depending on unit)</p> <ul style="list-style-type: none"> <li>None</li> <li>Closest</li> <li>2nd pump</li> <li>100% capacity</li> <li>Full capacity</li> <li>Free cooling</li> <li>General operation</li> <li>Safety-warning NO</li> <li>Safety-warning NC (only for Ch.DO1)</li> <li>Safety NO (excluding warning)</li> <li>Safety NC (excluding warning) (only for Ch.DO1)</li> <li>C1, C2 Safety NO</li> <li>Warning NO</li> <li>C1, C2 operation</li> <li>Cooling (only EWYQ)</li> <li>Heating (only EWYQ)</li> <li>Defrost (only EWYQ)</li> </ul> </td> <td> <p>Changeable analog input (4 available)</p> <ul style="list-style-type: none"> <li>None</li> <li>Status (mA, V, NTC, DI)</li> <li>Floating setpoint (mA, V, NTC*)</li> <li>Water temperature measurement (NTC*)</li> <li>Changeable DI, refer to Ch DI for possibilities (DI)</li> <li>Details of types:</li> <li>Type mA: 0, 20mA/4, 20mA (internal 5V or external power supply)</li> <li>Type V: 0-1V/0-5V/0-10V</li> <li>Type DI: DI (5V detection)</li> </ul> <p>*: for allowed NTC types and how to configure the software please contact your local dealer.</p> </td> </tr> </table>										<p>Changeable digital input (4 available)</p> <ul style="list-style-type: none"> <li>None</li> <li>Status</li> <li>Dual setpoint</li> <li>Remote on-off</li> <li>Capacity limitation 25%, 50%, 75% or setting</li> <li>Low noise (only for OPIF)</li> <li>Free cooling signal</li> <li>Fan forced on</li> </ul>	<p>Changeable analog output (1 available)</p> <ul style="list-style-type: none"> <li>None</li> <li>Status (mA, V, NTC, DI)</li> <li>Unit Capacity (mA, V)</li> <li>Details of types</li> <li>Type mA: 0, 20mA/4, 20mA</li> <li>Type V: 0-1V/0-5V/0-10V</li> </ul>	<p>Changeable digital output (6 or 5 available depending on unit)</p> <ul style="list-style-type: none"> <li>None</li> <li>Closest</li> <li>2nd pump</li> <li>100% capacity</li> <li>Full capacity</li> <li>Free cooling</li> <li>General operation</li> <li>Safety-warning NO</li> <li>Safety-warning NC (only for Ch.DO1)</li> <li>Safety NO (excluding warning)</li> <li>Safety NC (excluding warning) (only for Ch.DO1)</li> <li>C1, C2 Safety NO</li> <li>Warning NO</li> <li>C1, C2 operation</li> <li>Cooling (only EWYQ)</li> <li>Heating (only EWYQ)</li> <li>Defrost (only EWYQ)</li> </ul>	<p>Changeable analog input (4 available)</p> <ul style="list-style-type: none"> <li>None</li> <li>Status (mA, V, NTC, DI)</li> <li>Floating setpoint (mA, V, NTC*)</li> <li>Water temperature measurement (NTC*)</li> <li>Changeable DI, refer to Ch DI for possibilities (DI)</li> <li>Details of types:</li> <li>Type mA: 0, 20mA/4, 20mA (internal 5V or external power supply)</li> <li>Type V: 0-1V/0-5V/0-10V</li> <li>Type DI: DI (5V detection)</li> </ul> <p>*: for allowed NTC types and how to configure the software please contact your local dealer.</p>	<p>DAIKIN</p> <p style="text-align: right;">Drawing number: <b>4TW57579-2</b> Revision: <b>B</b> Page: <b>1</b></p>																																																																								
<p>Changeable digital input (4 available)</p> <ul style="list-style-type: none"> <li>None</li> <li>Status</li> <li>Dual setpoint</li> <li>Remote on-off</li> <li>Capacity limitation 25%, 50%, 75% or setting</li> <li>Low noise (only for OPIF)</li> <li>Free cooling signal</li> <li>Fan forced on</li> </ul>	<p>Changeable analog output (1 available)</p> <ul style="list-style-type: none"> <li>None</li> <li>Status (mA, V, NTC, DI)</li> <li>Unit Capacity (mA, V)</li> <li>Details of types</li> <li>Type mA: 0, 20mA/4, 20mA</li> <li>Type V: 0-1V/0-5V/0-10V</li> </ul>																																																																																					
<p>Changeable digital output (6 or 5 available depending on unit)</p> <ul style="list-style-type: none"> <li>None</li> <li>Closest</li> <li>2nd pump</li> <li>100% capacity</li> <li>Full capacity</li> <li>Free cooling</li> <li>General operation</li> <li>Safety-warning NO</li> <li>Safety-warning NC (only for Ch.DO1)</li> <li>Safety NO (excluding warning)</li> <li>Safety NC (excluding warning) (only for Ch.DO1)</li> <li>C1, C2 Safety NO</li> <li>Warning NO</li> <li>C1, C2 operation</li> <li>Cooling (only EWYQ)</li> <li>Heating (only EWYQ)</li> <li>Defrost (only EWYQ)</li> </ul>	<p>Changeable analog input (4 available)</p> <ul style="list-style-type: none"> <li>None</li> <li>Status (mA, V, NTC, DI)</li> <li>Floating setpoint (mA, V, NTC*)</li> <li>Water temperature measurement (NTC*)</li> <li>Changeable DI, refer to Ch DI for possibilities (DI)</li> <li>Details of types:</li> <li>Type mA: 0, 20mA/4, 20mA (internal 5V or external power supply)</li> <li>Type V: 0-1V/0-5V/0-10V</li> <li>Type DI: DI (5V detection)</li> </ul> <p>*: for allowed NTC types and how to configure the software please contact your local dealer.</p>																																																																																					

0	1	2	3	4	5	6	7	8	9
<p>(3) Fieldwiring: Digital input terminals</p>					<p>(4) Fieldwiring: Analog input terminals (connection is depending on type setting: NTC or mA or V or DI)</p>				
<p>(5) Fieldwiring: Analog output terminals (types: mA or V)</p>					<p>(6) Fieldwiring: Output terminals</p>				
<p>DAIKIN</p> <p style="text-align: right;">Drawing number: <b>4TW57579-2</b> Revision: <b>B</b> Page: <b>2</b></p>									

## 8 Sound data

### 8 - 1 Sound Power Spectrum

#### EWAQ-EWYQ-DAYN(N-P-B)

STD - Units LWE= 7°C / Tamb = 35°C	Sound power Lw per Octave band (dBA)								Total (dBA)
	63	125	250	500	1000	2000	4000	8000	LwA
EW(A/Y)Q080DAYN*	64	69	72	82	81	77	71	62	86
EW(A/Y)Q100DAYN*	62	66	71	79	82	80	74	64	86
EW(A/Y)Q130DAYN*	64	70	73	81	85	80	72	61	88
EW(A/Y)Q150DAYN*	65	74	75	85	84	80	74	65	89
EW(A/Y)Q180DAYN*	70	75	79	85	86	82	75	64	90
EW(A/Y)Q210DAYN*	67	74	79	85	86	83	76	64	90
EW(A/Y)Q(230/240)DAYN*	71	72	77	87	86	83	77	67	91
EW(A/Y)Q(250/260)DAYN*	71	72	77	87	86	83	77	67	91

OPLN - Units LWE= 7°C / Tamb = 35°C	Sound power Lw per Octave band (dBA)								Total (dBA)
	63	125	250	500	1000	2000	4000	8000	LwA
EW(A/Y)Q080DAYN*	62	67	70	80	79	75	69	60	84
EW(A/Y)Q100DAYN*	60	64	69	77	80	78	72	62	84
EW(A/Y)Q130DAYN*	61	67	70	78	82	77	69	58	85
EW(A/Y)Q150DAYN*	62	71	72	82	81	77	71	62	86
EW(A/Y)Q180DAYN*	68	73	77	83	84	80	73	62	88
EW(A/Y)Q210DAYN*	65	72	77	83	84	81	74	62	88
EW(A/Y)Q(230/240)DAYN*	68	69	74	84	83	80	74	64	88
EW(A/Y)Q(250/260)DAYN*	68	69	74	84	83	80	74	64	88

OPLN - Units LWE= 7°C / Tamb = 25°C	Sound power Lw per Octave band (dBA)								Total (dBA)
	63	125	250	500	1000	2000	4000	8000	LwA
EW(A/Y)Q080DAYN*	61	66	69	79	78	74	68	59	83
EW(A/Y)Q100DAYN*	59	63	68	76	79	77	71	61	83
EW(A/Y)Q130DAYN*	60	66	69	77	81	76	68	57	84
EW(A/Y)Q150DAYN*	60	69	70	80	79	75	69	90	84
EW(A/Y)Q180DAYN*	66	71	75	81	82	79	72	60	86
EW(A/Y)Q210DAYN*	63	70	75	81	82	79	72	60	86
EW(A/Y)Q(230/240)DAYN*	67	68	73	83	82	79	73	63	87
EW(A/Y)Q(250/260)DAYN*	67	68	73	83	82	79	73	63	87

#### NOTES

- 1 Values of Sound power according to ISO9614-2
- 2 LWE= Leaving Water Evaporator temperature (°C)  
Tamb= Ambient temperature

4TW57577-1C

## 9 Installation

### 9 - 1 Fixation and Foundation of Units

EWAQ-EWYQ080-150DAYN(N-P-B)

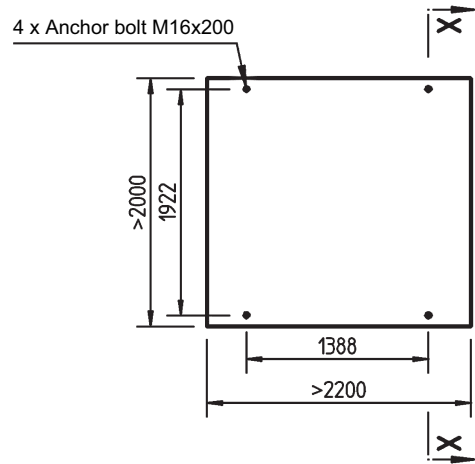

Fix anchor bolts into the concrete foundation. The concrete foundation should be higher than the floor level by approximately 100 mm for ease of plumbing work and better drain. Further, strength of the floor should be sufficient to support the weights of concrete foundation and unit. Be certain that foundation surface is even and flat.

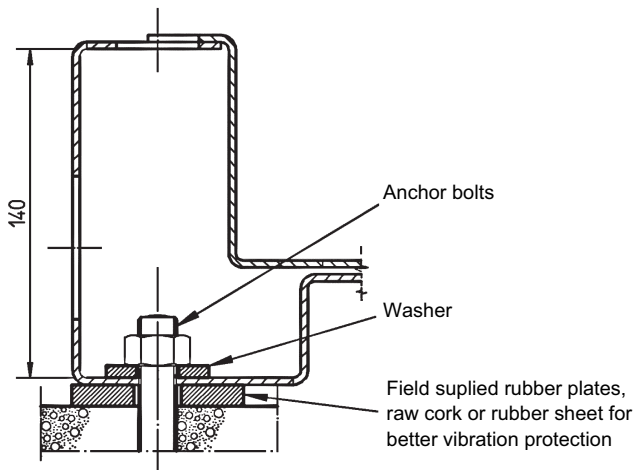
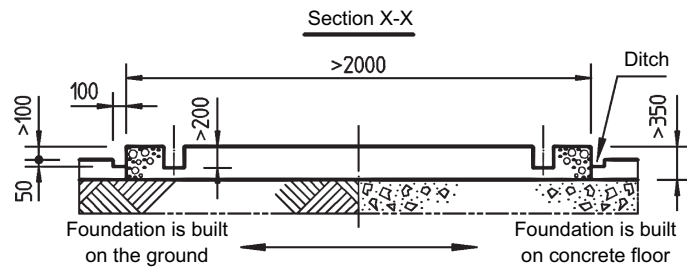

#### NOTES

- 1 The measurement tabulated is based on the fact the base is made in the ground or on a concrete floor. In case the base is made on a concrete floor. In case the base is made on a rigid concrete floor, it is possible to include thickness of concrete floor, in that of the base.
- 2 In case a base is made on concrete floor, be sure to provide a ditch as shown. It is important to extract drainage regardless of whether a base is made in the ground or on the concrete floor. (Ditch → Sewerage).
- 3 Ingredient ratio of the concrete is cement: 1, sand: 2, gravel: 3, which is standard and insert iron bars of  $\varnothing 10$  at every interval of 300mm. The edge of the concrete base should be planed.

4TW57599-1

## 9 Installation

### 9 - 1 Fixation and Foundation of Units

EWAQ-EWYQ180-210DAYN(N-P-B)

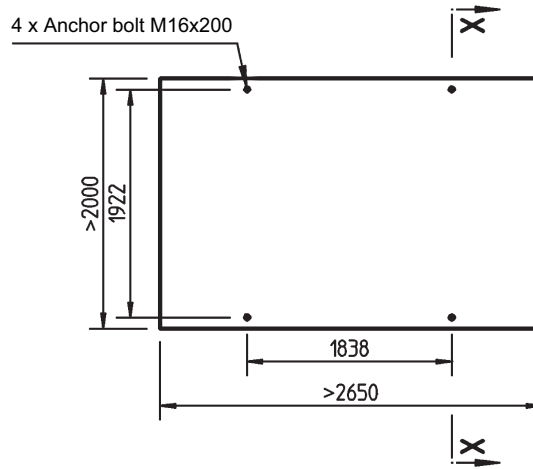

Fix anchor bolts into the concrete foundation. The concrete foundation should be higher than the floor level by approximately 100 mm for ease of plumbing work and better drain. Further, strength of the floor should be sufficient to support the weights of concrete foundation and unit. Be certain that foundation surface is even and flat.

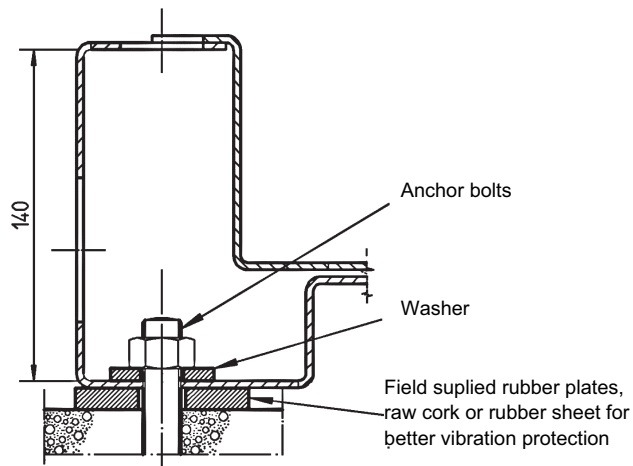
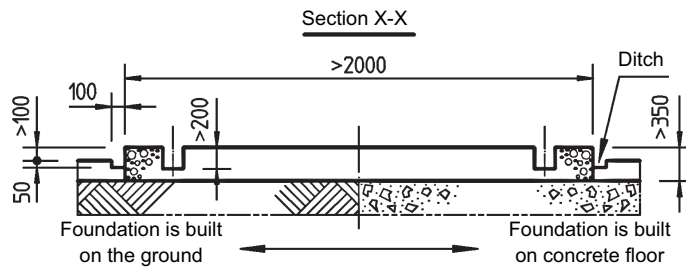

#### NOTES

- 1 The measurement tabulated is based on the fact the base is made in the ground or on a concrete floor. In case the base is made on a rigid concrete floor, it is possible to include thickness of concrete floor, in that of the base.
- 2 In case a base is made on concrete floor, be sure to provide a ditch as shown. It is important to extract drainage regardless of whether a base is made in the ground or on the concrete floor. (Ditch → Sewerage).
- 3 Ingredient ratio of the concrete is cement: 1, sand: 2, gravel: 3, which is standard and insert iron bars of  $\varnothing 10$  at every interval of 300mm. The edge of the concrete base should be planed.

4TW57619-1

## 9 Installation

### 9 - 1 Fixation and Foundation of Units

EWAQ240-260DAYN(N-P-B)\_EWYQ230-250DAYN(N-P-B)

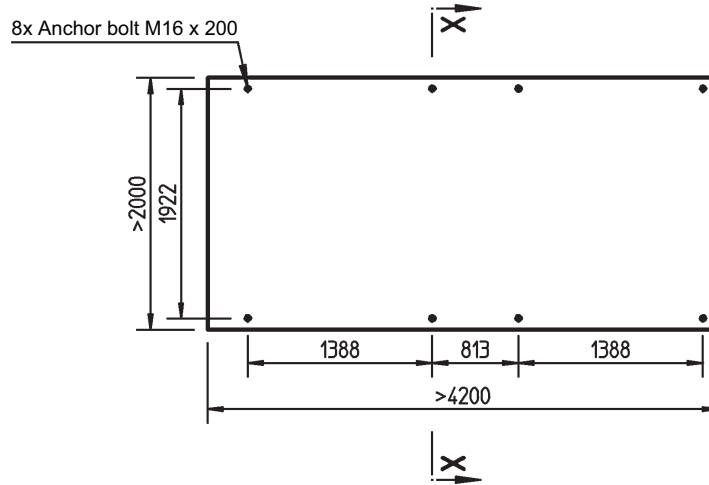

Fix anchor bolts into the concrete foundation. The concrete foundation should be higher than the floor level by approximately 100 mm for ease of plumbing work and better drain. Further, strength of the floor should be sufficient to support the weights of concrete foundation and unit. Be certain that foundation surface is even and flat.

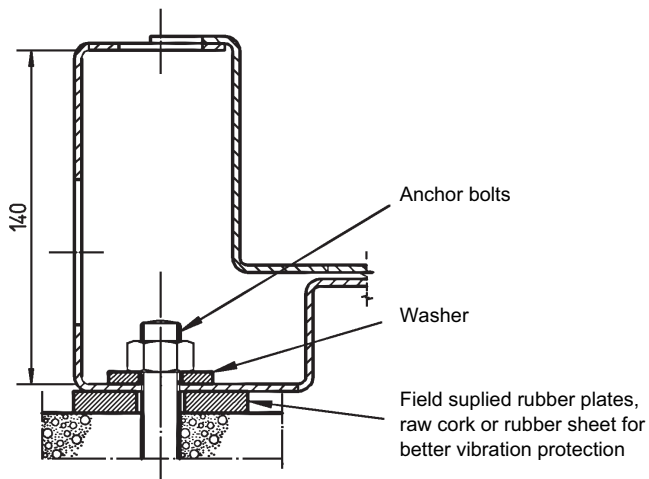
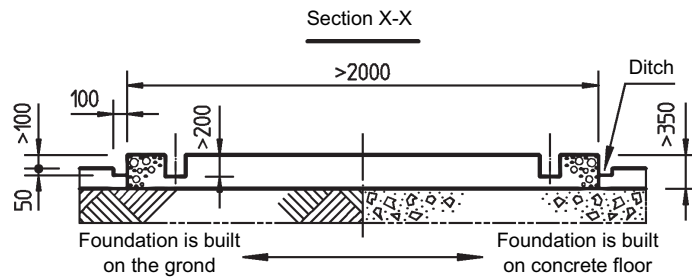

#### NOTES

- 1 The measurement tabulated is based on the fact the base is made in the ground or on a concrete floor. In case the base is made on a rigid concrete floor, it is possible to include thickness of concrete floor in that of the base.
- 2 In case a base is made on concrete floor, be sure to provide a ditch as shown. It is important to extract drainage regardless of whether a base is made in the ground or on the concrete floor. (Ditch → Sewerage).
- 3 Ingredient ratio of the concrete is cement: 1, sand:2, gravel:3, which is standard and insert iron bars of  $\varnothing 10$  at every interval of 300mm. The edge of the concrete base should be planed.

4TW57639-1

# 9 Installation

## 9 - 2 Water Charge, Flow and Quality

ITEMS (1) (5)	Cooling water (3)		Cooled water		Heated water (2)		Tendency if out of criteria
	Circulating system		Circulating water [Below 20°C]	Supply water (4)	High temperature		
	Circulating water	Once flow			Low temperature	High temperature	
pH	6.5~8.2	6.0~8.0	6.8~8.0	6.8~8.0	7.0~8.0	7.0~8.0	Corrosion + scale
Electrical conductivity	Below 80	Below 30	Below 40	Below 30	Below 30	Below 30	Corrosion + scale
	(Below 800)	(Below 300)	(Below 400)	(Below 300)	(Below 300)	(Below 300)	Corrosion + scale
Chloride ion	Below 200	Below 50	Below 50	Below 50	Below 50	Below 30	Corrosion
Sulfate ion	Below 200	Below 50	Below 50	Below 50	Below 50	Below 30	Corrosion
M-alkalinity (pH4.8)	Below 100	Below 50	Below 50	Below 50	Below 50	Below 50	Scale
Total hardness	Below 200	Below 70	Below 70	Below 70	Below 70	Below 70	Scale
Calcium hardness	Below 150	Below 50	Below 50	Below 50	Below 50	Below 50	Scale
Silica ion	Below 50	Below 30	Below 30	Below 30	Below 30	Below 30	Scale
Iron	Below 1.0	Below 0.3	Below 1.0	Below 0.3	Below 1.0	Below 0.3	Corrosion + scale
Copper	Below 0.3	Below 0.1	Below 1.0	Below 1.0	Below 1.0	Below 0.1	Corrosion
Sulfite ion	Not detectable	Not detectable	Not detectable	Not detectable	Not detectable	Not detectable	Corrosion
Ammonium ion	Below 1.0	Below 0.1	Below 1.0	Below 0.1	Below 0.1	Below 0.1	Corrosion
Remaining chloride	Below 0.3	Below 0.3	Below 0.3	Below 0.3	Below 0.1	Below 0.3	Corrosion
Free carbide	Below 4.0	Below 4.0	Below 4.0	Below 4.0	Below 0.4	Below 4.0	Corrosion
Stability index	6.0~7.0	---	---	---	---	---	Corrosion + scale

3TW50179-1

- Names, definitions and units are according to JIS K 0101. Units and figures between brackets are old units published as reference only.
- In case of using heated water (more than 40°C), corrosion is generally noticeable. Especially when the iron material is in direct contact with water without any protection shields, it is desirable to give the valid measures for corrosion. e.g. chemical measure.
- In the cooling water using hermetic cooling tower, closed circuit water is according to heated water standard, and scattered water is according to cooling water standard.
- Supply water is considered drink water, industrial water and ground water except for genuine water, neutral water and soft water.
- The above mentioned items are representable items in corrosion and scale cases.



# 10 Operation range

## 10 - 1 Operation Range

EWYQ080-100-180-210-230-250DAYN(N-P-B)

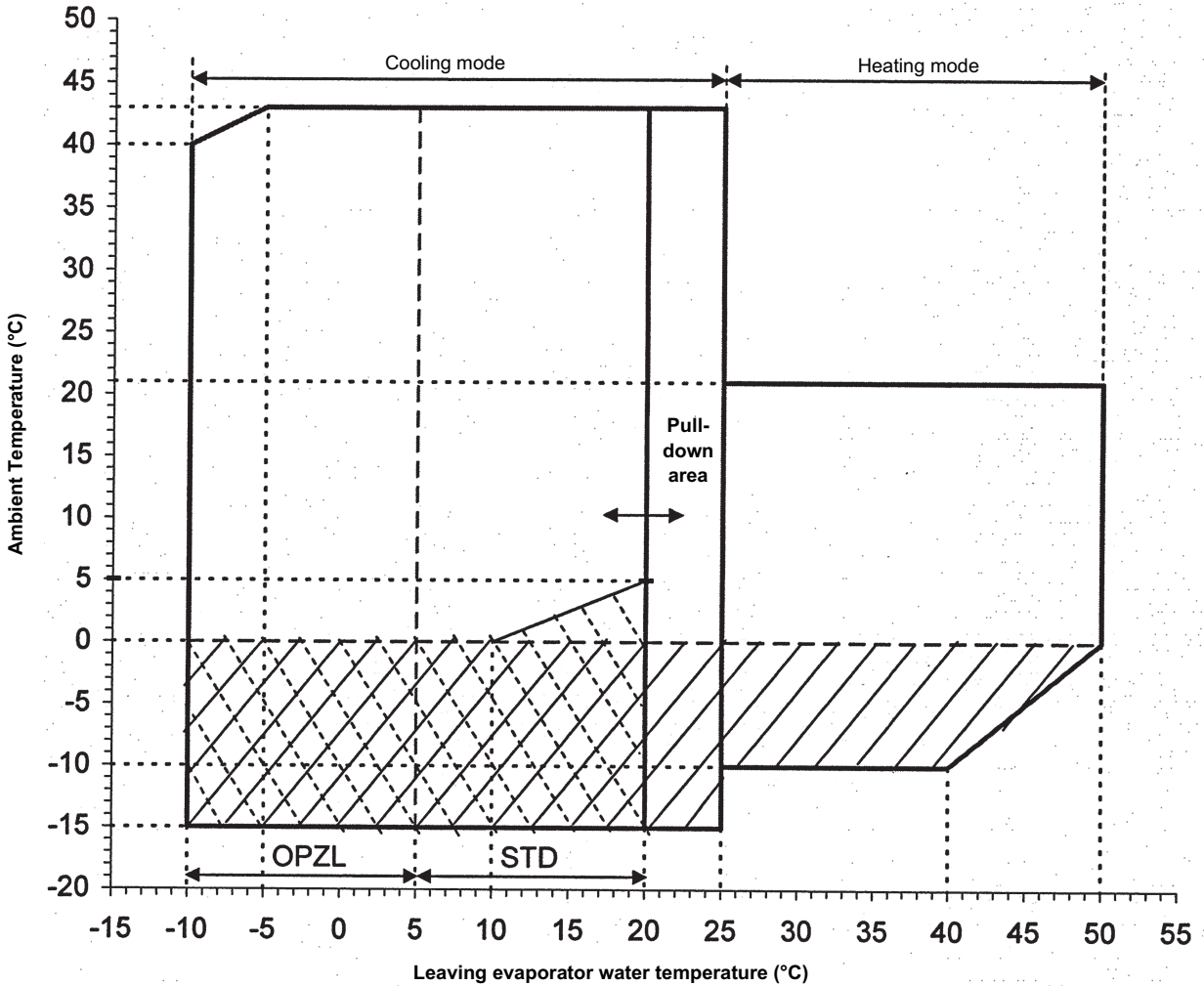

STD: Standard unit

OPZL: Leaving water evaporator from -10 to 5°C by use of glycol



Protect the water circuit against freezing by:

\* OR OP10: heater tape

\* Or filling up the system with a glycol solution



OPIF: Option Inverter Fans EWYQ080-100-180-210-230-250

# 10 Operation range

## 10 - 1 Operation Range

EWYQ130-150DAYN(N-P-B)

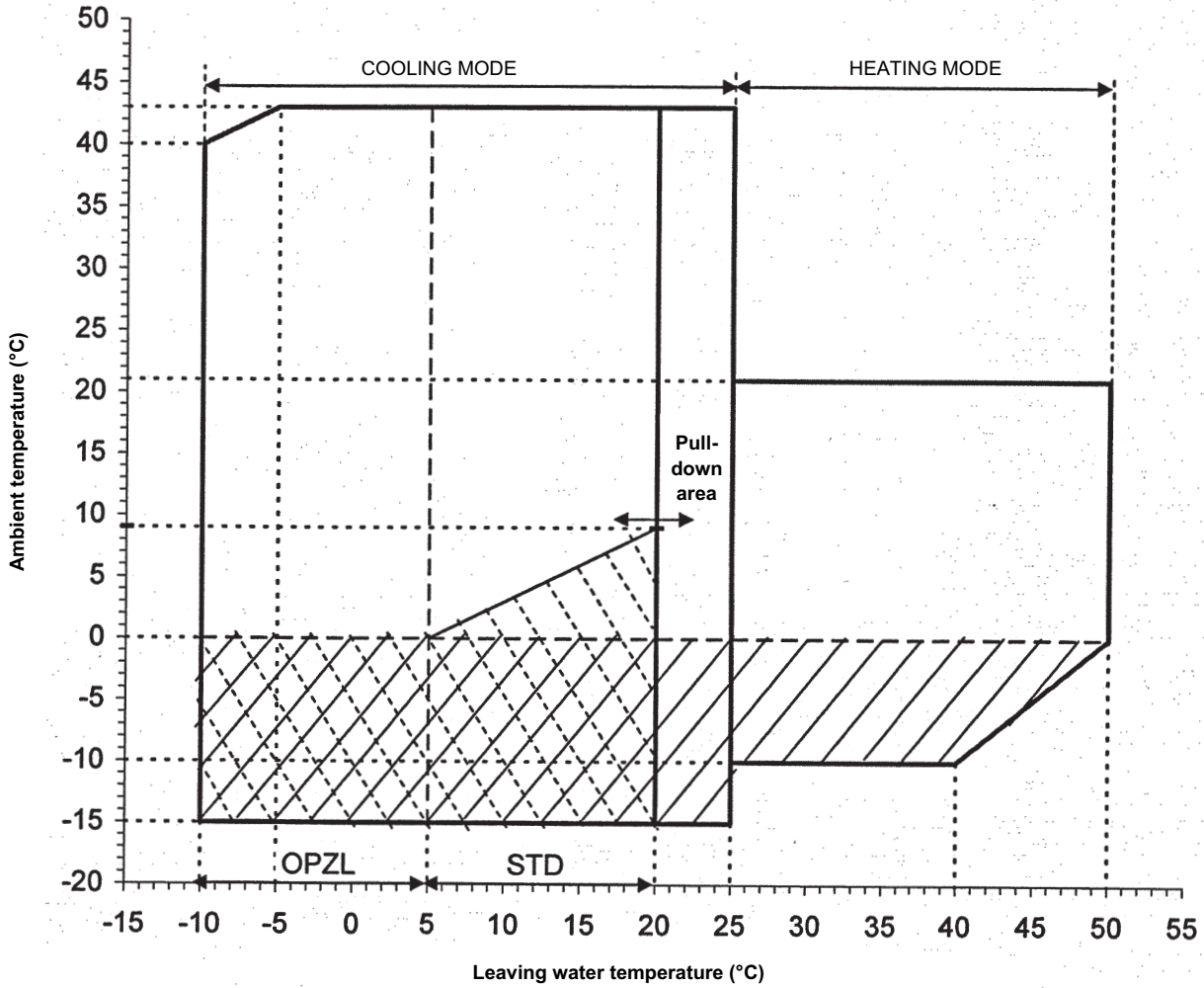

STD: Standard unit

OPZL: Leaving water evaporator from -10 to 5°C by use of glycol



Protect the water circuit against freezing by:

\* OR OP10: heater tape

\* Or filling up the system with a glycol solution



OPIF Option Inverter Fans EWYQ130-150

4TW57673-1

# 11 Hydraulic performance

## 11 - 1 Water Pressure Drop Curve Evaporator

EWYQ080-100DAYN(OPHP)

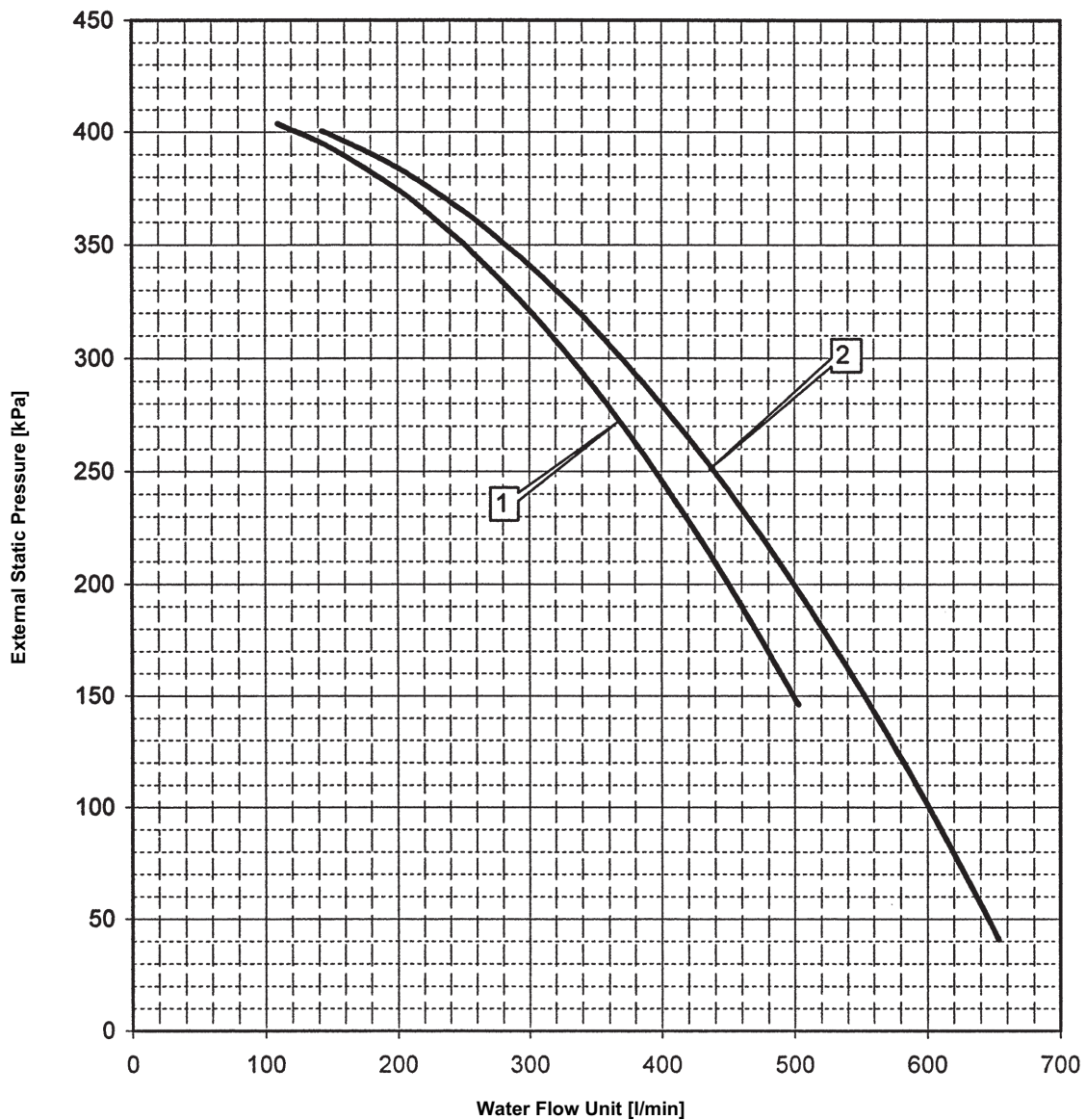

1. EWYQ080DAYN\* + OPHP
2. EWYQ100DAYN\* + OPHP

**Warning:**

Selecting a flow outside the curves can cause damage to or malfunction of the unit. See also minimum and maximum allowed water flowrange in the technical specifications.

# 11 Hydraulic performance

## 11 - 1 Water Pressure Drop Curve Evaporator

EWYQ080-100DAYN\*

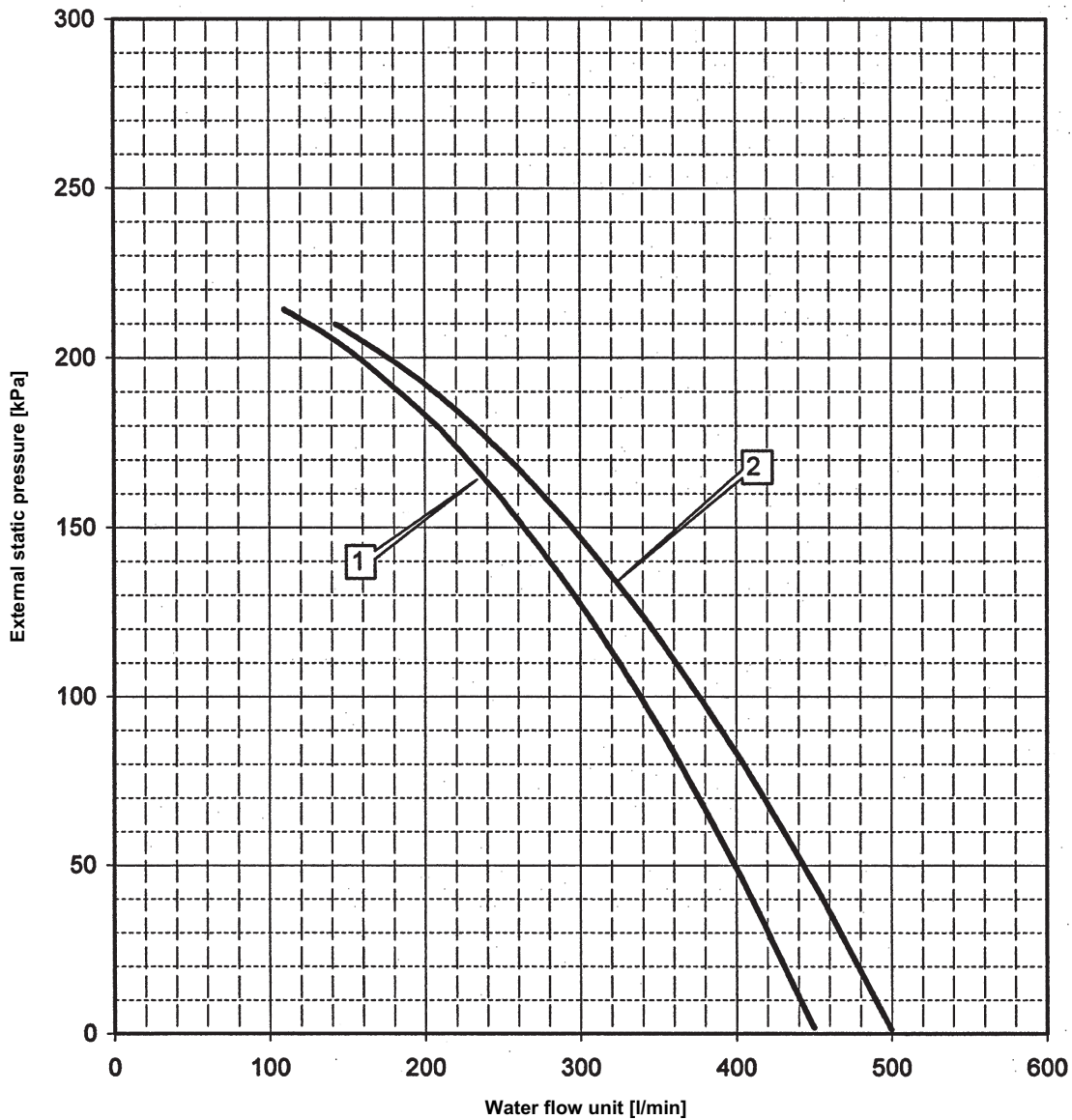

- 1. EWAQ080DAYN\* + OPSP/OTP
- 2. EWAQ100DAYN\* + OPSP/OTP

**Warning:**  
 Selecting a flow outside the curves can cause damage to or malfunction of the unit. See also minimum and maximum allowed water flowrange in the technical specifications.

4TW57659-4A

# 11 Hydraulic performance

## 11 - 1 Water Pressure Drop Curve Evaporator

EWYQ80-100DAYN(N-P-B)

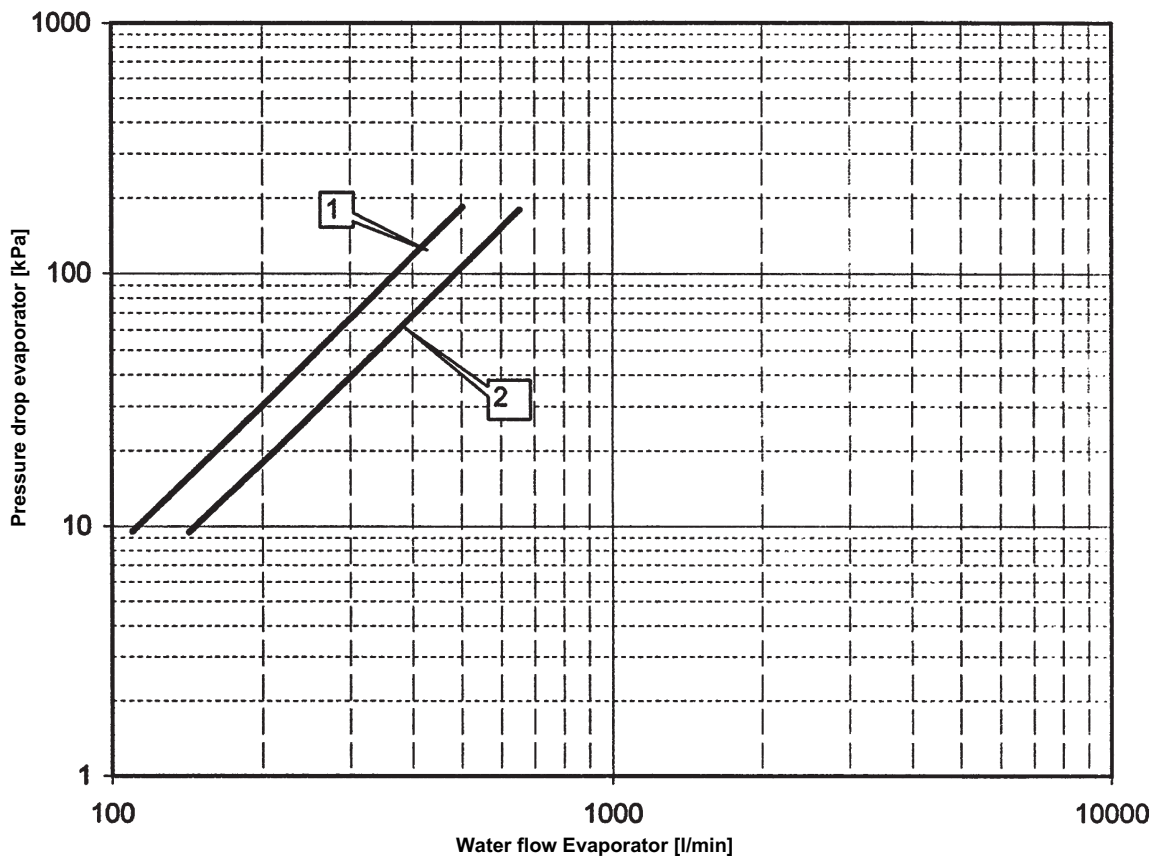

- 1. EWYQ80DAYN\*
- 2. EWYQ100DAYN\*

**Warning:**

Selecting a flow outside the curves can cause damage to or malfunction of the unit. See also minimum and maximum allowed water flowrange in the technical specifications.

# 11 Hydraulic performance

## 11 - 1 Water Pressure Drop Curve Evaporator

EWYQ130-210DAYN (OPHP)

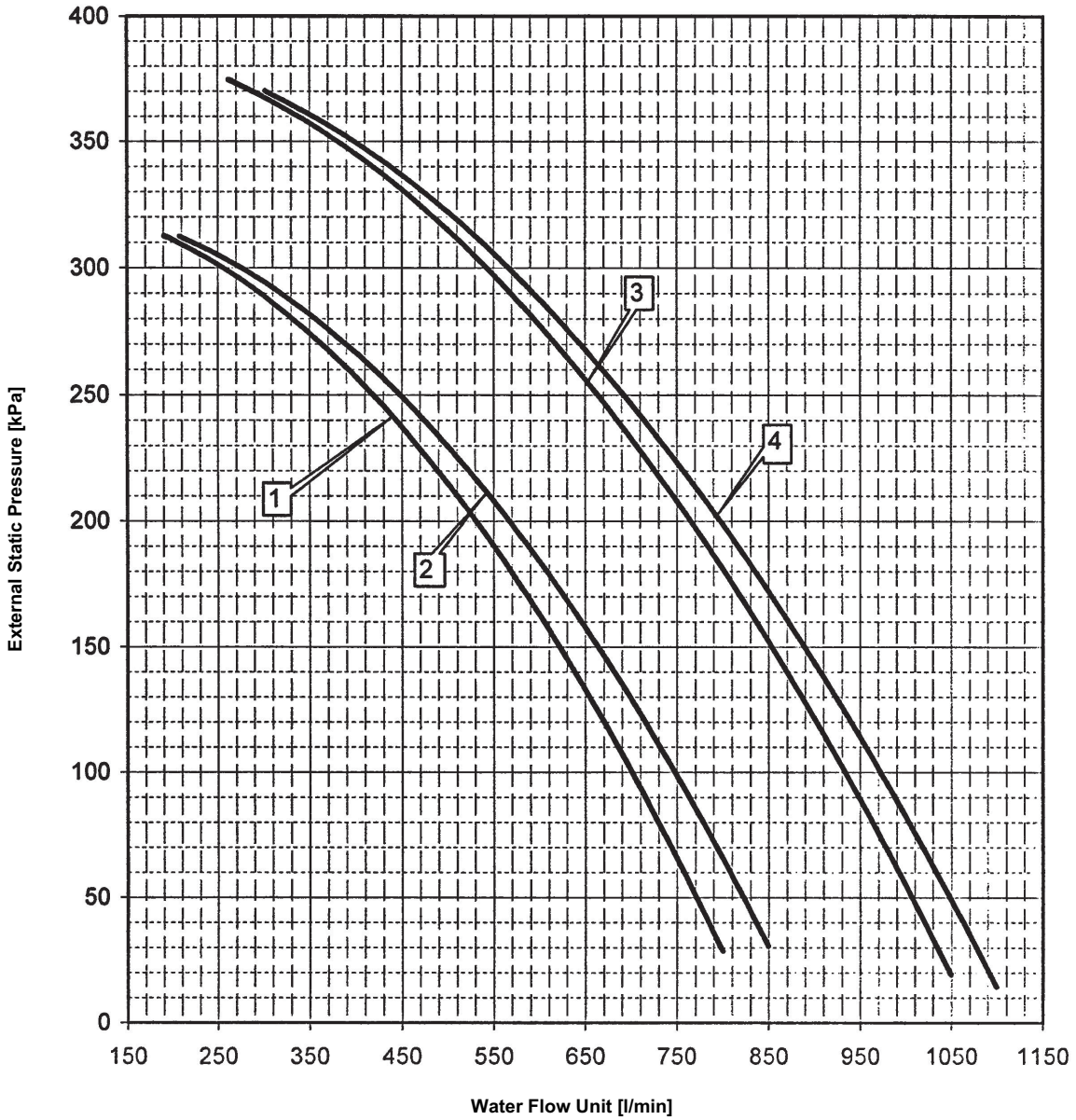

- 1. EWYQ130DAYN\* + OPHP
- 2. EWYQ150DAYN\* + OPHP
- 3. EWYQ180DAYN\* + OPHP
- 4. EWYQ210DAYN\* + OPHP

**Warning:**

Selecting a flow outside the curves can cause damage to or malfunction of the unit. See also minimum and maximum allowed water flowrange in the technical specifications.

4TW57679-9



# 11 Hydraulic performance

## 11 - 1 Water Pressure Drop Curve Evaporator

EWYQ130-210DAYN\*

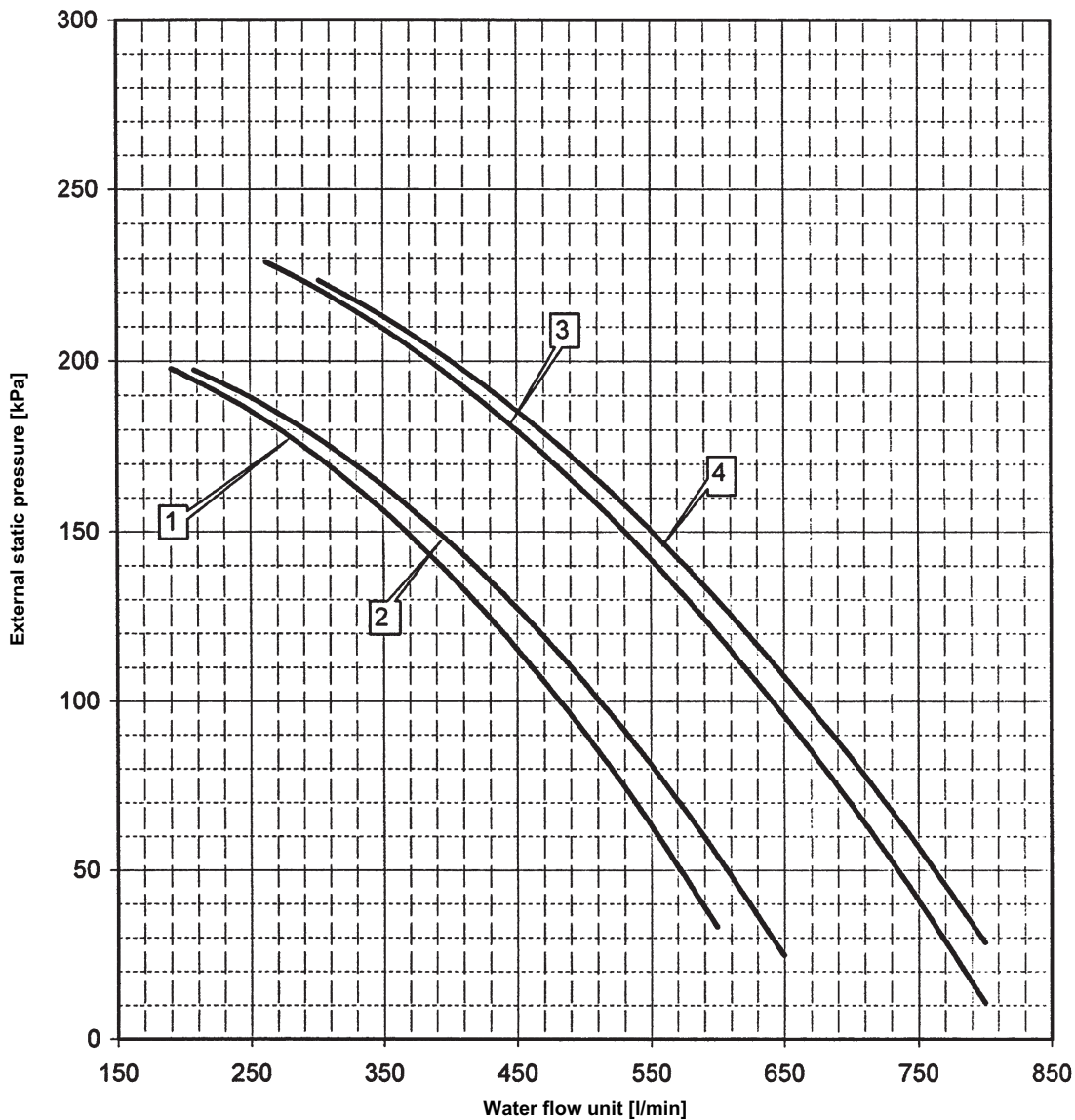

1. EWYQ130DAYN\* + OPSP/OPTP
2. EWYQ150DAYN\* + OPSP/OPTP
3. EWYQ180DAYN\* + OPSP/OPTP
4. EWYQ210DAYN\* + OPSP/OPTP

**Warning:**

Selecting a flow outside the curves can cause damage to or malfunction of the unit. See also minimum and maximum allowed water flowrange in the technical specifications.

# 11 Hydraulic performance

## 11 - 1 Water Pressure Drop Curve Evaporator

EWYQ130-210DAYN(N-P-B)

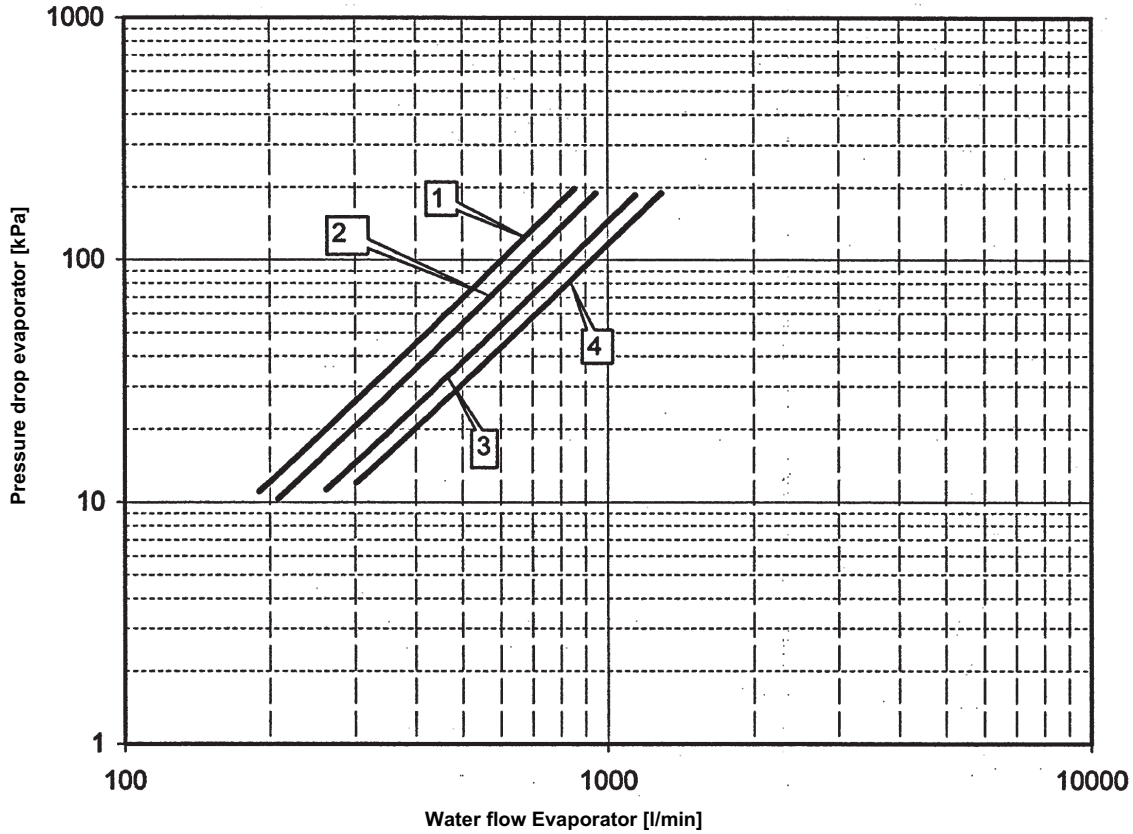

- 1. EWYQ130DAYN\*
- 2. EWYQ150DAYN\*
- 3. EWYQ180DAYN\*
- 4. EWYQ210DAYN\*

**Warning:**  
 Selecting a flow outside the curves can cause damage to or malfunction of the unit. See also minimum and maximum allowed water flowrange in the technical specifications.

4TW57679-5



# 11 Hydraulic performance

## 11 - 1 Water Pressure Drop Curve Evaporator

EWYQ230-250DAYN\*

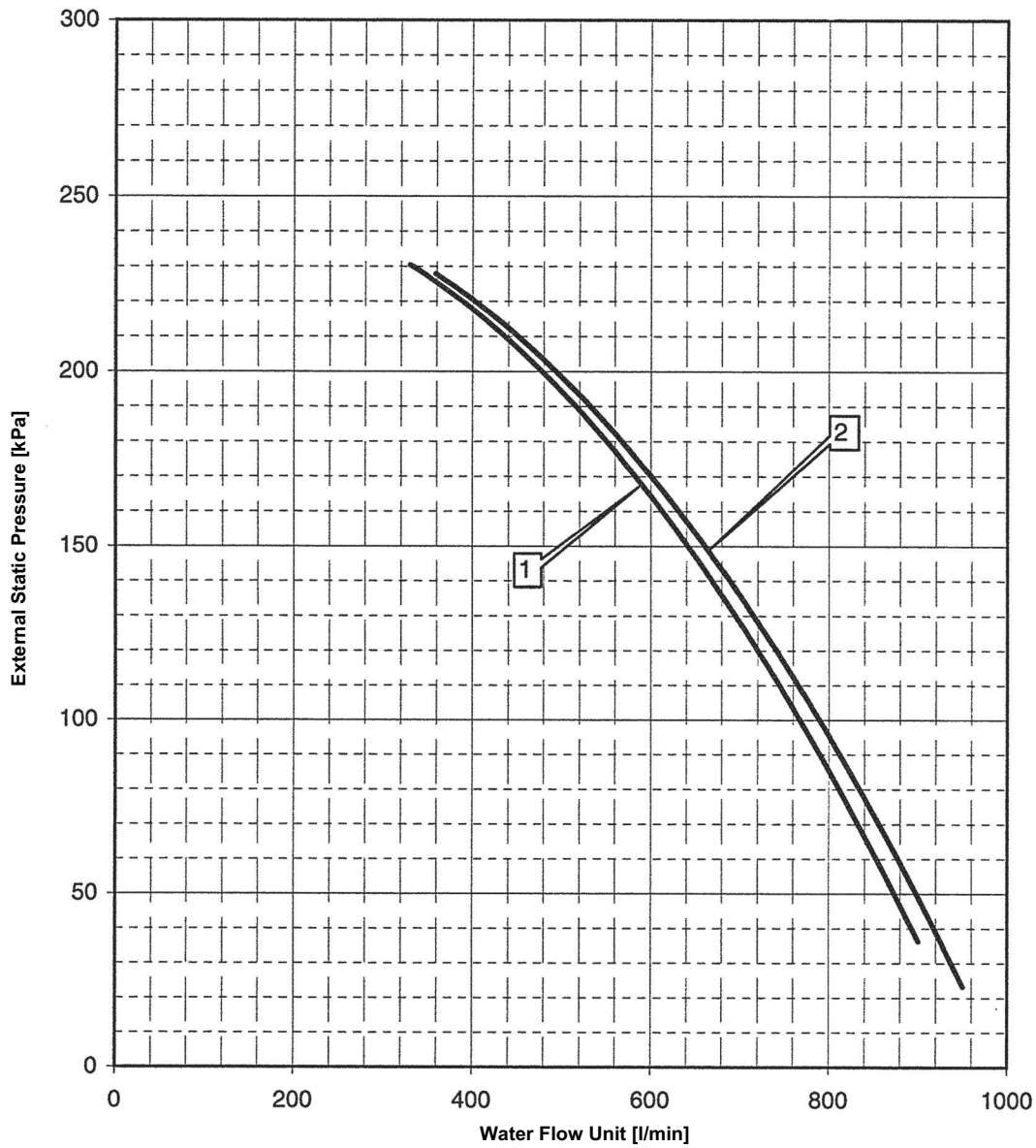

1. EWAQ230DAYN\* + OPSP/OTP
2. EWAQ250DAYN\* + OPSP/OTP

**Warning:**

Selecting a flow outside the curves can cause damage to or malfunction of the unit. See also minimum and maximum allowed water flowrange in the technical specifications.

4TW57719-4B

# 11 Hydraulic performance

## 11 - 1 Water Pressure Drop Curve Evaporator

EWYQ230-250DAYN(N-P-B)

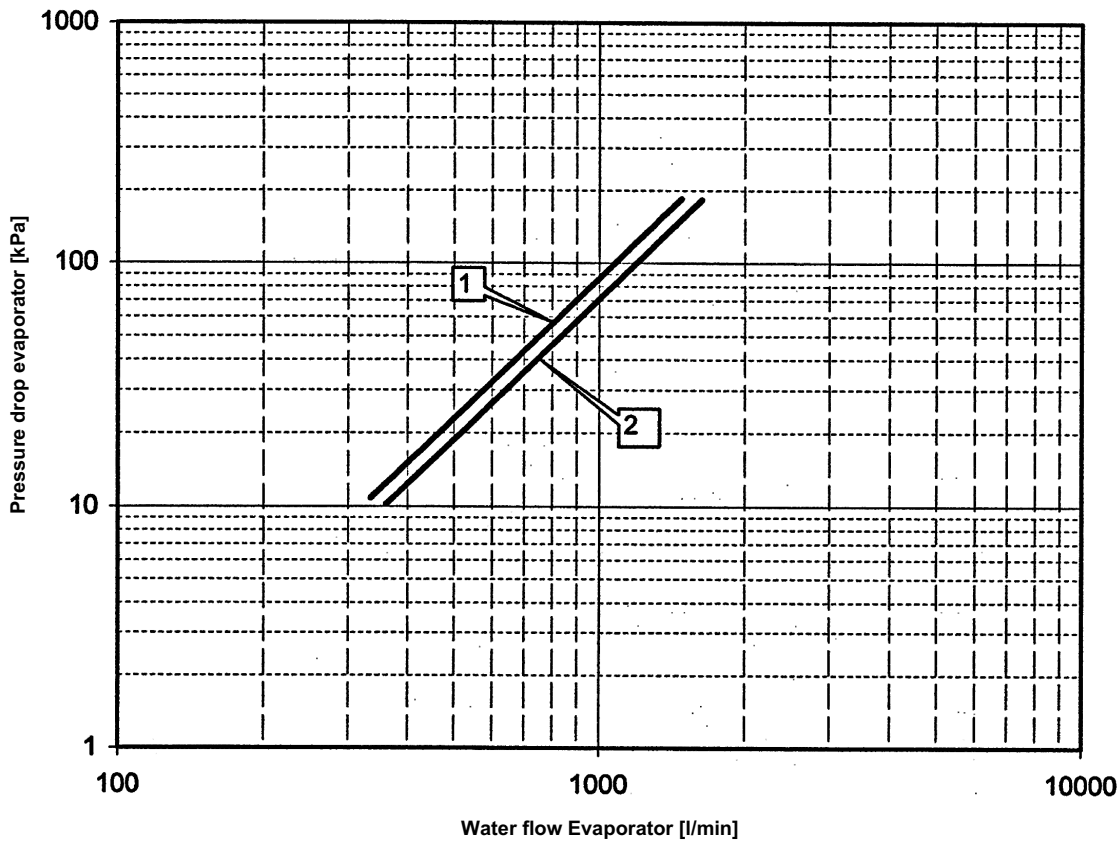

- 1. EWYQ230DAYN\*
- 2. EWYQ250DAYN\*

**Warning:**  
 Selecting a flow outside the curves can cause damage to or malfunction of the unit. See also minimum and maximum allowed water flowrange in the technical specifications.

4TW57719-5

# 11 Hydraulic performance

## 11 - 2 Static Pressure Drop Unit

EWYQ080-100DAYN(N)

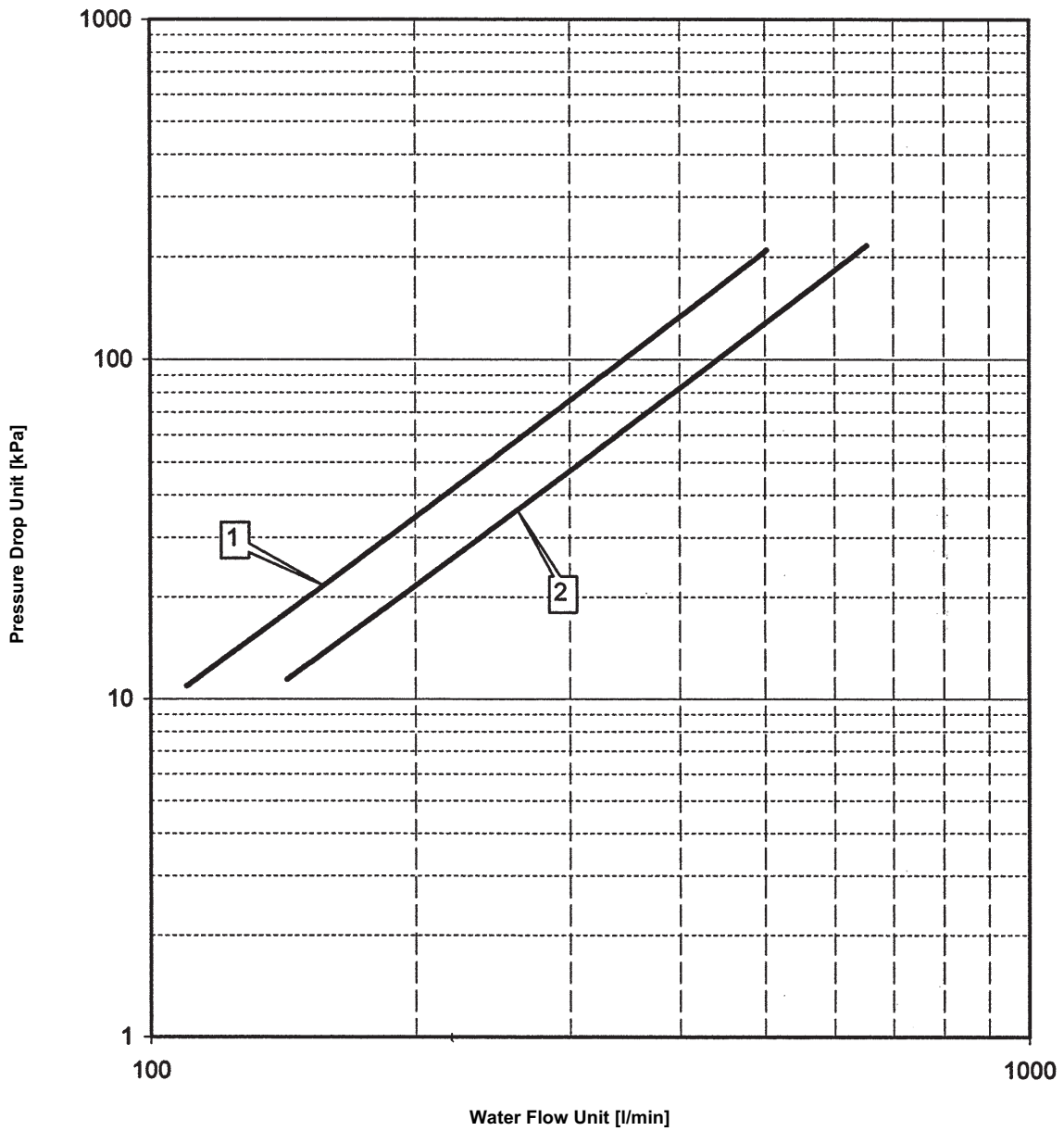

1. EWYQ080DAYN\* Standard model
2. EWYQ100DAYN\* Standard model

**Warning:**

Selecting a flow outside the curves can cause damage to or malfunction of the unit. See also minimum and maximum allowed water flowrange in the technical specifications.

4TW57659-7

# 11 Hydraulic performance

## 11 - 2 Static Pressure Drop Unit

EWYQ130-210DAYN(N)

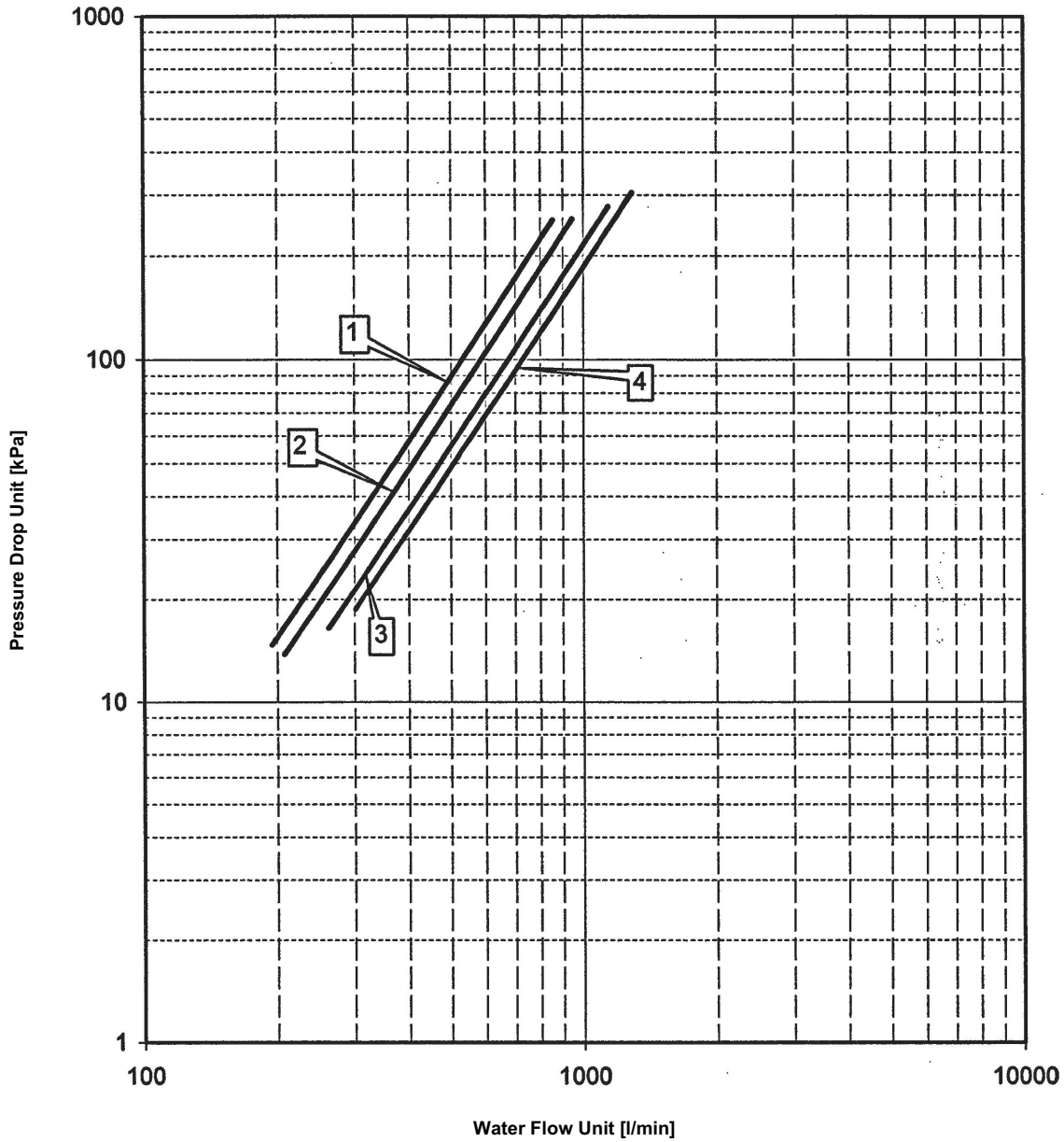

1. EWYQ130DAYN\* Standard model
2. EWYQ150DAYN\* Standard model
3. EWYQ180DAYN\* Standard model
4. EWYQ210DAYN\* Standard model

**Warning:**

Selecting a flow outside the curves can cause damage to or malfunction of the unit. See also minimum and maximum allowed water flowrange in the technical specifications.

4TW57679-7

# 11 Hydraulic performance

## 11 - 2 Static Pressure Drop Unit

EWYQ230-250DAYN(N)

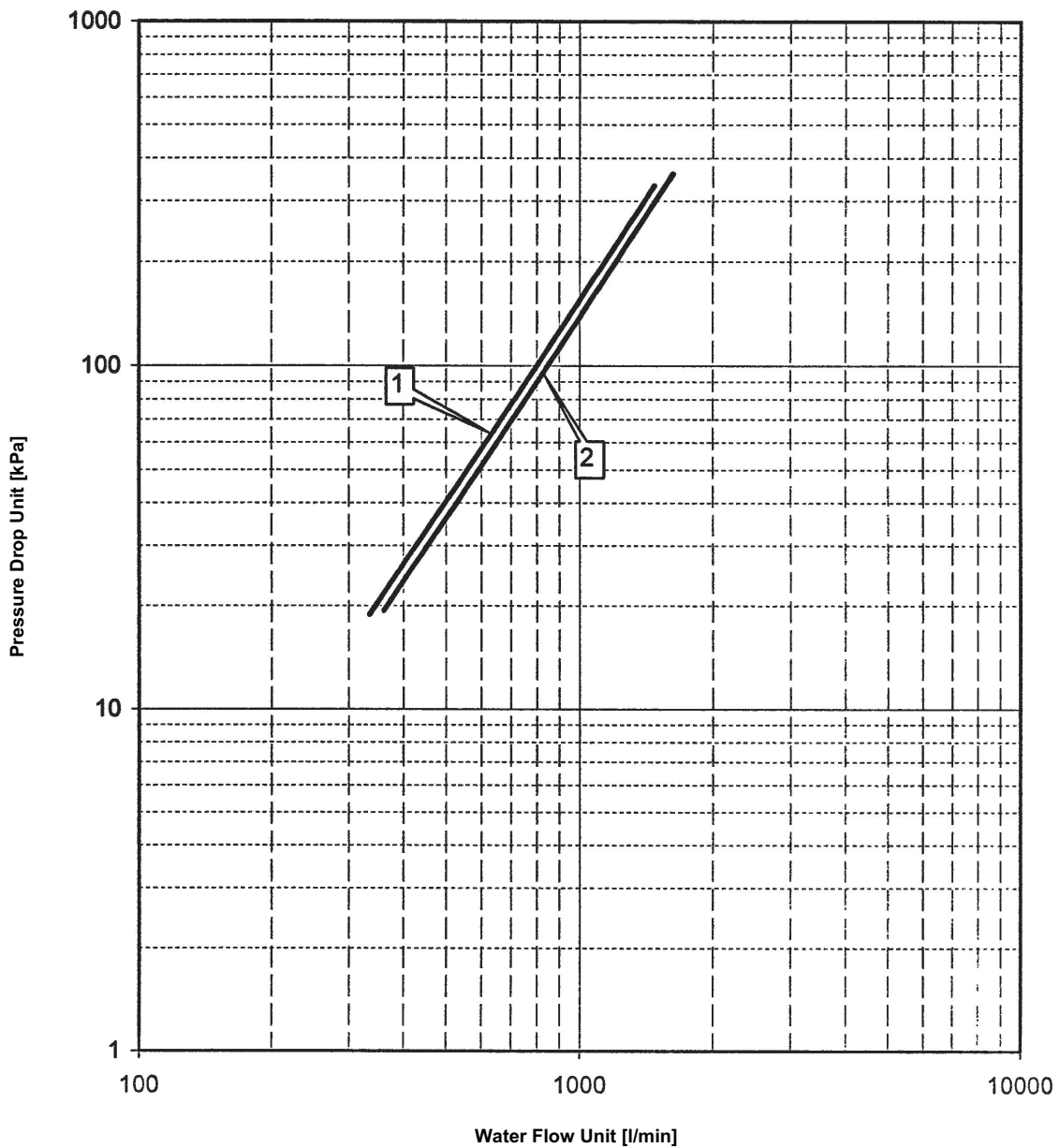

1. EWYQ230DAYN\* Standard model
2. EWYQ250DAYN\* Standard model

**Warning:**

Selecting a flow outside the curves can cause damage to or malfunction of the unit. See also minimum and maximum allowed water flowrange in the technical specifications.

In all of us,  
a green heart



Daikin's unique position as a manufacturer of air conditioning equipment, compressors and refrigerants has led to its close involvement in environmental issues. For several years Daikin has had the intention to become a leader in the provision of products that have limited impact on the environment. This challenge demands the eco design and development of a wide range of products and an energy management system, resulting in energy conservation and a reduction of waste.



Daikin Europe NV, participates in the Eurovent Certification programme for Air conditioners (AC), Liquid Chilling Packages (LCP) and Fan coil units (FCU). Check ongoing validity of certificate online: [www.eurovent-certification.com](http://www.eurovent-certification.com) or using: [www.certiflash.com](http://www.certiflash.com)

The present publication is drawn up by way of information only and does not constitute an offer binding upon Daikin Europe N.V. Daikin Europe N.V. has compiled the content of this publication to the best of its knowledge. No express or implied warranty is given for the completeness, accuracy, reliability or fitness for particular purpose of its content and the products and services presented therein. Specifications are subject to change without prior notice. Daikin Europe N.V. explicitly rejects any liability for any direct or indirect damage, in the broadest sense, arising from or related to the use and/or interpretation of this publication. All content is copyrighted by Daikin Europe N.V.



Daikin products are distributed by: