

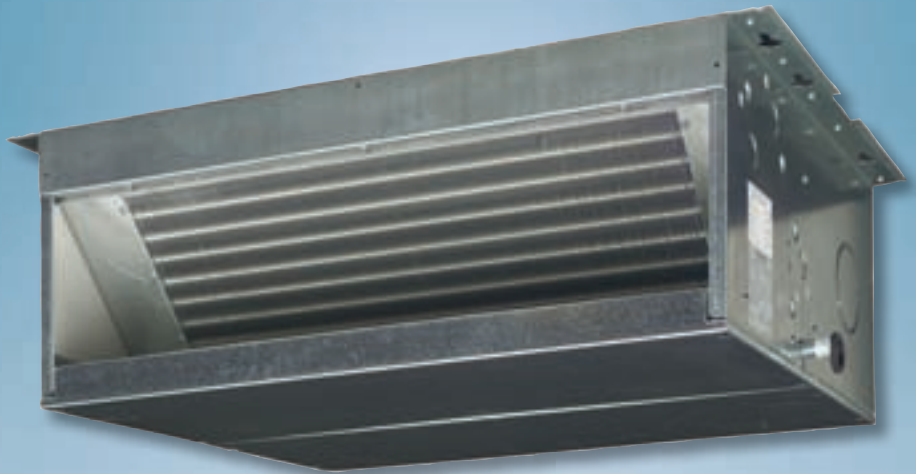

Fan Coil Units

Technical Data

Flexi type unit



ECDEN11-400

FWD-AT/AF



Fan Coil Units

Technical Data

Flexi type unit



ECDEN11-400

FWD-AT/AF

FWD-AT/AF

I Flexi type unit

FWD-AT..... 3

1

FWD-AF..... 33

2

TABLE OF CONTENTS

FWD-AT

1	Specifications	2
	Technical Specifications	2
	Electrical Specifications	2
2	Electrical data	3
	Electrical data	3
3	Options	4
	Options	4
4	Control systems	5
	Control systems	5
5	Capacity tables	6
	Cooling Capacity Tables	6
	Cooling Capacity Tables Glycol 40 %	8
	Heating Capacity Tables	9
	Capacity Correction Factor	10
6	Power consumption	11
7	Dimensional drawings	15
	Dimensional drawings	15
8	Wiring diagrams	17
	Wiring diagrams - Single Phase	17
9	Sound data	18
	Sound Level Data	18
10	Installation	22
	Installation Method	22
11	Operation range	27
	Operation range	27
12	Hydraulic performance	28
	Water Pressure Drop Curve Evaporator	28

1 Specifications

1-1 Technical Specifications				FWD04AT	FWD06AT	FWD08AT	FWD10AT	FWD12AT	FWD16AT	FWD18AT	
Cooling capacity	Total capacity	High	kW	3.90 (1)	6.20 (1)	7.80 (1)	8.82 (1)	11.90 (1)	16.40 (1)	18.30 (1)	
	Sensible capacity	High	kW	3.08 (1)	4.65 (1)	6.52 (1)	7.16 (1)	9.36 (1)	12.80 (1)	14.10 (1)	
Heating capacity	2-Pipe	High	kW	4.05 (2)	7.71 (2)	9.43 (2)	10.79 (2)	14.45 (2)	19.81 (2)	21.92 (2)	
Power input	High		W	234	349	443		714		1,197	
	Low		W	130	247	261		328		704	
	Nom.		W	173	294	336		473		966	
Casing	Colour	Not painted (galvanised)									
	Material	Galvanised sheet metal									
Dimensions	Unit	Height	mm	280				352			
		Width	mm	754	964	1,174			1,384		
	Depth	mm	559				718				
Weight	Unit		kg	33	41	47	49	65	77	80	
Heat exchanger	Rows	Quantity		3			4	3	4	5	
	Stages	Quantity		10				14			
	Fin pitch		mm	2.1	1.8	2.1					
	Face area		m ²	0.138	0.190	0.243		0.340	0.414		
	Water volume		l	1.06	1.42	1.79	2.38	2.5	4.02	5.03	
Water flow	Cooling		l/h	674	1,064	1,339	1,514	2,056	2,833	3,140	
	Heating		l/h	674	1,064	1,339	1,514	2,056	2,833	3,140	
Water pressure drop	Cooling		kPa	17	24		16	26	34	45	
	Heating		kPa	14	20		13	21	28	37	
Fan	Type	Centrifugal multi-blade, double suction									
	Quantity			1	2						
	Air flow rate	High	m ³ /h	800	1,250	1,600		2,200	3,000		
	Available pressure	High	Pa	66	58	68	64	97	145	134	
Fan motor	Speed	Steps		3 (high, medium, low)							
	Model	Closed induction, B class insulation, winding thermal cut-out									
Sound power level	High		dBA	66	69	72		74	78		
	Nom.		dBA	61	63	67			73		
	Low		dBA	54	59	62		60	69		
Piping connections	Drain	OD	mm	16							
Insulation material	Class 1 self-extinguishing										
Vibration insulation	Rubber ring for fan motor										
Air filter	Acrylic - Filtering class EU2										
Water connections	Std. heat exchanger		inch	3/4				1			

1-2 Electrical Specifications				FWD04AT	FWD06AT	FWD08AT	FWD10AT	FWD12AT	FWD16AT	FWD18AT
Power supply	Phase	1~								
	Frequency		Hz	50						
	Voltage		V	230						
Current input	High		A	0.95	1.58	1.97		3.21	5.37	
	Medium		A	0.74	1.39	1.52		2.08	4.38	
	Low		A	0.57	1.18	1.20		1.50	3.26	
Required wire section			mm ²	1		1.5		2	2.5	
Required fuses			A	2			4		6	

Notes

- (1) Cooling: 2 pipe: air 27°CDB, 19°CWB; entering water 7°C; leaving water 12°C at nominal air flow and ESP
- (2) Heating: 2 pipe: air 20°CDB; entering water 50°C; water flow as in cooling mode at nominal air flow and ESP
- (3) Maximum Power input at 0Pa ESP
- (4) Sound level at 0Pa ESP
- (5) Current input at 0Pa ESP

2 Electrical data

2 - 1 Electrical data

FWD-AT/AF

FWD-AT/AF		Power input electric heater	Current Absorption	Power supply
Unit	Electric heater	kW	A	V / ~ / Hz
FWD04AT/AF	EDEHS04A6	2.0	8.7	230V +- 10% / 1~/50Hz
FWD06AT/AF	EDEHS06A6	3.0	4.3	400V +- 10% / 3~/50Hz
	EDEHB06A6	6.0	8.7	
FWD08AT/AF	EDEHS10A6	4.5	6.5	400V +- 10% / 3~/50Hz
	EDEHB10A6	9.0	13.0	
FWD10AT/AF	EDEHS10A6	4.5	6.5	400V +- 10% / 3~/50Hz
	EDEHB10A6	9.0	13.0	
FWD12AT/AF	EDEHS12A6	4.5	6.5	400V +- 10% / 3~/50Hz
	EDEHB12A6	9.0	13.0	
FWD16AT/AF	EDEHS18A6	9.0	13.0	400V +- 10% / 3~/50Hz
	EDEHB18A6	12.0	17.3	
FWD18AT/AF	EDEHS18A6	9.0	13.0	400V +- 10% / 3~/50Hz
	EDEHB18A6	12.0	17.3	

4TW60221-3

1
2

3 Options

3 - 1 Options

1
3

FWD-AT/AF										
	FWD-AT/AF	04	06	08	10	12	16	18	Notes/remarks	
Electric heater	EDEH(S)(B)..A6	EDEH04A6	EDEH(S)(B)06A6	EDEH(S)(B)10A6		EDEH(S)(B)12A6	EDEH(S)(B)18A6		Requires electronic Controller	
2-pipe ON-OFF 3 way motor driven valve complete with mounting kit	ED2MV..A6	ED2MV04A6	ED2MV10A6			ED2MV12A6	ED2MV18A6		For FWD 12 16 18 only motor valve (piping not included)	
4-pipe ON-OFF 3 way motor driven valve complete with mounting kit	ED4MV..A6	ED4MV04A6	ED4MV10A6			2 x ED2MV12A6	2 x ED2MV18A6		For FWD 12 16 18 only motor valve (piping not included)	
Fan stop thermostat	YFSTA6	YFSTA6								
Motorised fresh air intake louvers	EDMFA..A6	EDMFA04A6	EDMFA06A6	EDMFA10A6		EDMFA12A6	EDMFA18A6			
Auxiliary drain pan (vertical models)	EDDPV..A6	EDDPV10A6				EDDPV18A6				
Fcu Controller - Standard version	FWEC1A					FWEC1A				water probe included
Fcu Controller - Advanced version	FWEC2A					FWEC2A				water probe included
Fcu Controller - Advanced plus version	FWEC3A					FWEC3A				water probe included
Fcu temperature sensor kit	FWTSKA					FWTSKA				
Fcu relative humidity sensor kit	FWHSKA					FWHSKA				
Power interface	EPIB6					EPIB6				
Master slave for connection of up to 4 units	EPIMSB6					EPIMSB6				

4TW60229-2B(1)

FWD-AT/AF														
Description	Electric heater	2-pipe ON-OFF 3 way motor driven valve complete with mounting kit	4-pipe ON-OFF 3 way motor driven valve complete with mounting kit	Fan stop thermostat	Motorised fresh air intake louvers	Auxiliary drain pan (horizontal models)	Auxiliary drain pan (vertical models)	Fcu Controller - Standard version	Fcu Controller - Advanced version	Fcu Controller - Advanced plus version	Fcu temperature sensor kit	Fcu relative humidity sensor kit	Power interface	Master slave for connection of up to 4 units
	EDEH(S)(B)..A6	ED2MV..A6	ED4MV..A6	YFSTA6	EDMFA..A6	EDDPH..A6	EDDPV..A6	FWEC1A	FWEC2A	FWEC3A	FWTSKA	FWHSKA	EPIB6	EPIMSB6
Electric heater	X				X	X	X	X	X	X	X	X	X	X
2-pipe ON-OFF 3 way motor driven valve complete with mounting kit	X	X			X	X	X	X	X	X	X	X	X	X
4-pipe ON-OFF 3 way motor driven valve complete with mounting kit			X		X	X	X	X	X	X	X	X	X	X
Fan stop thermostat				X	X	X							X	X
Motorised fresh air intake louvers	X	X	X	X	X	X	X	X	X	X	X	X	X	X
Auxiliary drain pan (horizontal models)	X	X	X	X	X			X	X	X	X	X	X	X
Auxiliary drain pan (vertical models)	X	X	X	X	X			X	X	X	X	X	X	X
Fcu Controller - Standard version	X	X	X		X	X	X				X	X	X*	X*
Fcu Controller - Advanced version	X	X	X		X	X	X				X	X	X*	X*
Fcu Controller - Advanced plus version	X	X	X		X	X	X				X	X	X*	X*
Fcu temperature sensor kit	X	X	X		X	X	X	X	X	X		X	X	X
Fcu relative humidity sensor kit	X	X	X		X	X	X		X	X	X		X	X
Power interface	X	X	X	X	X	X	X	X*	X*	X*	X	X		X*
Master slave for connection of up to 4 units	X	X	X	X	X	X	X	X*	X*	X*	X	X	X*	











NOTE
* = Power interface necessary only for FWD16AT/AF and FWD18AT/AF

4TW60229-2B(2)

4 Control systems

4 - 1 Control systems

FWD-AT/AF

	Cool/heat changeover			Options		Basic control functions		Control features		
										
2-pipe	X					X	X	X	X	
	X			X		X	X		X	
	X				X	X	X	X	X	
	X			X	X	X	X		X	
		X				X	X			
		X		X		X	X			
			X		X	X	X	X	X	X
4-pipe	X			X		X	X		X	
	X					X	X	X	X	
			X			X	X	X		X
			X	X		X	X		X	X

SYMBOLS



Manual cool/heat changeover.



Automatic cool/heat changeover based on water temperature.



Automatic cool/heat changeover based on air temperature.



Control of the 3-way/4pipe ON/OFF valve. The water valve shut-off once the desired temperature is reached.



The controller controls the electric heater as integration or replacement of the hot water heating system. When the operating mode selector switch is turned on "electric heater" and the electric heater is turned on, the fan runs continuously at medium speed. When the operating mode selector switch is turned to "electric heater" and the electric heater is turned on, the fan runs continuously at medium speed.



The fan speed can be set at one of the 3 speeds (low, medium or maximum) by turning the operation mode selector.



The fan speed is switched automatically based on the difference between the temperature set on the thermostat and the room temperature.



Optimised comfort cooling. When the fan coil has reached the desired setpoint, the fan will operate at medium speed and at regular intervals to ensure constant room temperature and lower sound.



The controller prevents the fan coil unit from operating in one mode, if the required water temperature is not achieved to operate in the selected mode.



The dead zone is a temperature interval close to the set temperature. When the air is warmer/cooler than the top/lower limit of the neutral zone, the cooling/heating mode is selected.

5 Capacity tables

5 - 1 Cooling Capacity Tables

1
5

FWD-AT/AF

Air temperature (°C DB - °C WB)		22-16															
Water temperature (Entering °C - leaving °C)		6-11				7-12				8-13				9-14			
Model	Air flow	Total cooling capacity	Sensible cooling capacity	Water flow	Water pressure drop	Total cooling capacity	Sensible cooling capacity	Water flow	Water pressure drop	Total cooling capacity	Sensible cooling capacity	Water flow	Water pressure drop	Total cooling capacity	Sensible cooling capacity	Water flow	Water pressure drop
	m ³ /h	W	W	l/h	kPa	W	W	l/h	kPa	W	W	l/h	kPa	W	W	l/h	kPa
FWD04AT/AF	400	1410	1250	241	3	1240	1240	213	2	1150	1150	197	2	1050	1050	180	2
	600	1850	1720	317	5	1590	1590	273	4	1440	1440	247	3	1310	1310	226	2
	800	2370	2200	406	7	2000	2000	343	5	1790	1790	307	4	1570	1570	269	3
FWD06AT/AF	800	2550	2290	437	5	2190	2190	376	4	2000	2000	343	3	1830	1830	314	3
	1000	3160	2780	542	7	2650	2650	455	5	2360	2360	405	4	2050	2050	352	3
	1250	3810	3320	653	10	3160	3160	543	7	2830	2830	486	6	2490	2490	427	5
FWD08AT/AF	1200	3470	3470	595	6	3120	3120	535	5	2750	2750	472	4	2500	2500	429	3
	1400	3930	3930	674	7	3550	3550	609	6	3150	3150	541	5	2720	2720	468	4
	1600	4360	4360	748	9	3950	3950	677	7	3520	3520	604	6	3070	3070	528	5
FWD10AT/AF	1200	3830	3830	657	4	3550	3550	610	3	3280	3280	563	3	3000	3000	515	2
	1400	4320	4320	742	5	3870	3870	663	4	3560	3560	612	3	3260	3260	560	3
	1600	4870	4870	835	6	4380	4380	751	5	3840	3840	660	4	3490	3490	600	3
FWD12AT/AF	1600	5600	5080	961	7	4660	4660	799	5	4130	4130	709	4	3630	3630	624	3
	1900	6550	5940	1123	9	5380	5380	923	6	4810	4810	825	5	4200	4200	721	4
	2000	6840	6210	1174	10	6050	6050	1038	8	5420	5420	931	7	4770	4770	819	5
FWD16AT/AF	2000	7760	6650	1331	9	5980	5980	1026	6	5350	5350	919	5	4780	4780	820	4
	2500	9350	8100	1604	13	7190	7190	1233	8	6470	6470	1111	7	5730	5730	984	5
	3000	10790	9460	1851	16	8280	8280	1421	10	7480	7480	1284	8	6660	6660	1144	7
FWD18AT/AF	2000	9140	7440	1569	13	7490	6750	1286	9	6060	6060	1041	6	5430	5430	932	5
	2500	10930	9070	1875	18	9040	8290	1551	13	7280	7280	1250	9	6540	6540	1124	7
	3000	12570	10630	2156	23	10430	9750	1792	17	8400	8400	1443	11	7560	7560	1298	9

4TW60222-1_A (Sheet 1/7)

FWD-AT/AF

Air temperature (°C DB - °C WB)		25-18															
Water temperature (Entering °C - leaving °C)		6-11				7-12				8-13				9-14			
Model	Air flow	Total cooling capacity	Sensible cooling capacity	Water flow	Water pressure drop	Total cooling capacity	Sensible cooling capacity	Water flow	Water pressure drop	Total cooling capacity	Sensible cooling capacity	Water flow	Water pressure drop	Total cooling capacity	Sensible cooling capacity	Water flow	Water pressure drop
	m ³ /h	W	W	l/h	kPa	W	W	l/h	kPa	W	W	l/h	kPa	W	W	l/h	kPa
FWD04AT/AF	400	2170	1620	371	6	1840	1490	317	5	1460	1350	252	3	1330	1330	227	3
	600	3010	2270	515	11	2590	2110	443	8	2110	1930	364	6	1800	1800	310	4
	800	3740	2860	641	16	3220	2660	554	12	2660	2450	457	9	2240	2240	385	6
FWD06AT/AF	800	4220	3070	724	12	3630	2840	623	9	2960	2580	508	6	2490	2490	428	5
	1000	5030	3660	968	17	4340	3390	745	13	3580	3100	616	9	2990	2990	511	7
	1250	5980	4330	1026	23	5180	4020	889	17	4310	3690	740	13	3540	3540	609	9
FWD08AT/AF	1200	6020	4740	1032	15	5180	4410	889	12	3870	3870	666	7	3550	3550	608	6
	1400	6770	5400	1161	19	5840	5040	1004	14	4370	4370	749	9	4010	4010	688	7
	1600	7470	6040	1282	22	6470	5650	1109	17	4830	4830	828	10	4440	4440	763	9
FWD10AT/AF	1200	6650	5130	1141	10	5640	4720	968	7	4260	4260	731	4	3870	3870	666	4
	1400	7570	5900	1300	12	6470	5460	1109	9	4870	4870	835	6	4450	4450	763	5
	1600	8440	6640	1447	15	7240	6170	1242	11	5450	5450	936	7	4990	4990	857	6
FWD12AT/AF	1600	8930	6680	1530	16	7730	6200	1328	12	6380	5680	1098	9	5250	5250	904	6
	1900	10220	7720	1753	20	8860	7180	1519	16	7370	6610	1267	11	6030	6030	1037	8
	2200	11420	8710	1958	24	9920	8120	1703	19	8280	7490	1422	14	6760	6760	1159	10
FWD16AT/AF	2000	11600	8520	1987	18	10180	7950	1746	15	8640	7340	1483	11	6670	6670	1145	7
	2500	13770	10270	2362	25	12120	9610	2077	20	10330	8910	1775	15	7970	7970	1368	9
	3000	15780	11930	2707	32	13890	11180	2383	25	11870	10410	2038	19	9150	9150	1573	12
FWD18AT/AF	2000	12920	9310	2218	25	11510	8720	1976	20	9990	8110	1714	15	8300	7450	1426	11
	2500	15380	11280	2635	33	13700	10600	2351	27	11900	9880	2045	21	9940	9120	1706	15
	3000	17650	13180	3028	42	15720	12400	2700	34	13670	11590	2347	27	11440	10740	1966	20

4TW60222-1_B (Sheet 2/7)

5 Capacity tables

5 - 1 Cooling Capacity Tables

FWD-AT/AF																	
Air temperature (°C DB - °C WB)		27-19															
Water temperature (Entering °C - leaving °C)		6-11				7-12				8-13				9-14			
Model	Air flow	Total cooling capacity	Sensible cooling capacity	Water flow	Water pressure drop	Total cooling capacity	Sensible cooling capacity	Water flow	Water pressure drop	Total cooling capacity	Sensible cooling capacity	Water flow	Water pressure drop	Total cooling capacity	Sensible cooling capacity	Water flow	Water pressure drop
	m³/h	W	W	l/h	kPa	W	W	l/h	kPa	W	W	l/h	kPa	W	W	l/h	kPa
FWD04AT/AF	400	2580	1870	443	8	2280	1750	392	7	1950	1620	335	5	1570	1480	270	3
	600	3560	2600	608	14	3150	2450	540	12	2720	2290	468	9	2250	2110	385	6
	800	4400	3270	756	21	3900	3080	674	17	3390	2890	583	13	2660	2660	457	9
FWD06AT/AF	800	4990	3520	857	16	4430	3300	760	13	3830	3070	659	10	3160	2820	544	7
	1000	5920	4180	1015	22	5270	3930	904	18	4570	3660	785	14	3800	3380	652	10
FWD08AT/AF	1250	6970	4940	1195	29	6200	4650	1064	24	5380	4340	924	19	4500	4020	772	13
	1200	7100	5420	1217	20	6310	5110	1084	17	5460	4790	936	13	4230	4230	727	8
	1400	7970	6160	1368	25	7090	5820	1217	20	6150	5470	1055	16	4760	4760	817	10
FWD10AT/AF	1600	8790	6890	1508	30	7800	6520	1339	24	6800	6130	1166	19	5260	5260	904	12
	1200	7910	5890	1357	13	6990	5530	1199	11	5990	5140	1026	8	4690	4690	806	5
	1400	8960	6760	1537	17	7950	6360	1364	13	6840	5930	1174	10	5340	5340	918	7
FWD12AT/AF	1600	9970	7600	1710	20	8820	7160	1514	16	7640	6700	1310	12	5950	5950	1022	8
	1600	10490	7630	1800	21	9350	7170	1606	17	8130	6700	1397	13	6780	6190	1166	10
	1900	11970	8800	2056	26	10690	8290	1832	22	9310	7760	1598	17	7800	7200	1339	12
FWD16AT/AF	2200	13370	9920	2293	32	11900	9360	2056	26	10410	8780	1786	20	8740	8170	1501	15
	2000	13450	9670	2308	24	12100	9130	2077	20	10660	8560	1829	16	9100	7970	1562	12
	2500	15950	11640	2736	32	14360	11010	2466	27	12670	10360	2178	21	10850	9670	1865	16
FWD18AT/AF	3000	18260	13510	3136	41	16400	12800	2833	34	14520	12060	2491	27	12450	11290	2138	21
	2000	14790	10490	2538	31	13430	9930	2304	26	11990	9350	2059	21	10440	8740	1793	17
	2500	17610	12710	3020	42	15990	12050	2743	35	14270	11370	2448	29	12430	10660	2135	23
FWD18AT/AF	3000	20150	14820	3456	53	18300	14100	3140	45	16370	13320	2812	37	14270	12520	2452	29

4TW60222-1_C (Sheet 3/7)

5 Capacity tables

5 - 2 Cooling Capacity Tables Glycol 40 %

FWD-AT/AF

Cooling mode

Glycol percentage in weight	Freezing temperature (°C)	Capacity correction factor	Pressure drop correction factor
0	0	1	1.00
10	-4	0.93	1.09
20	-10	0.84	1.18
30	-16	0.76	1.27
40	-24	0.76	1.36

Heating mode

Glycol percentage in weight	Freezing temperature (°C)	Capacity correction factor	Pressure drop correction factor
0	0	1	1.00
10	-4	0.98	1.08
20	-10	0.97	1.11
30	-16	0.94	1.22
40	-24	0.91	1.33

NOTES

Correction factors are based on an average value (at rated water flow rate). This can cause deviation depending on conditions used.
The Fan Coil Selection software will provide an accurate result at all conditions.

4TW60228-1B

5 Capacity tables

5 - 3 Heating Capacity Tables

FWD-AT

Air temperature (°C)		20												
Water temperature (Entering °C - leaving °C)		50-45				60-50			70-60			90-70		
Model	Air flow	Heating capacity	Water flow	Water pressure drop	Heating capacity	Water flow	Water pressure drop	Heating capacity	Water flow	Water pressure drop	Heating capacity	Water flow	Water pressure drop	
	m ³ /h	W	l/h	kPa	W	l/h	kPa	W	l/h	kPa	W	l/h	kPa	
FWD04AT	400	3010	526	9	3830	335	4	4970	436	6	6660	295	3	
	600	4070	709	15	5160	450	7	6700	587	10	8940	396	5	
	800	4990	871	22	6300	551	9	8200	720	15	10910	482	7	
FWD06AT	800	5760	1004	18	7320	641	8	9490	832	12	12690	562	6	
	1000	6790	1181	23	8600	752	10	11170	979	16	14900	659	7	
	1250	7960	1386	31	10050	878	13	13080	1147	21	17400	768	10	
FWD08AT	1200	7920	1379	21	10030	878	9	13030	1145	14	17370	767	7	
	1400	8830	1541	25	11170	976	11	14520	1274	17	19320	853	8	
	1600	9690	1688	29	12220	1069	13	15920	1397	20	21150	932	9	
FWD10AT	1200	8940	1559	14	11380	994	6	14730	1292	9	19730	871	4	
	1400	10040	1750	17	12740	1112	7	16530	1451	11	22090	976	5	
	1600	11080	1930	20	14040	1228	9	18230	1598	13	24330	1073	6	
FWD12AT	1600	11760	2048	21	14960	1307	9	19380	1699	14	25930	1145	7	
	1900	13350	2326	27	16930	1480	12	21970	1930	18	29340	1296	9	
	2200	14830	2585	32	18770	1638	14	24400	2142	21	32520	1436	10	
FWD16AT	2000	15010	2617	24	19180	1678	11	24740	2171	16	33240	1465	8	
	2500	17750	3092	32	22600	1976	14	29220	2563	22	39140	1728	10	
	3000	20270	3528	41	25760	2250	18	33350	2927	27	44570	1966	13	
FWD18AT	2000	16300	2837	31	20970	1832	14	26890	2358	21	36350	1606	10	
	2500	19430	3384	42	24930	2178	19	32040	2812	28	43180	1904	14	
	3000	22340	3892	53	28590	2498	24	36810	3229	36	49510	2185	17	

4TW60222-1_A (Sheet 4/7)

FWD-AT

Air temperature (°C)		22												
Water temperature (Entering °C - leaving °C)		50-45				60-50			70-60			90-70		
Model	Air flow	Heating capacity	Water flow	Water pressure drop	Heating capacity	Water flow	Water pressure drop	Heating capacity	Water flow	Water pressure drop	Heating capacity	Water flow	Water pressure drop	
	m ³ /h	W	l/h	kPa	W	l/h	kPa	W	l/h	kPa	W	l/h	kPa	
FWD04AT	400	2780	486	8	3590	313	4	4730	415	6	6410	283	3	
	600	3760	655	13	4840	423	6	6380	560	9	8600	380	5	
	800	4610	803	19	5910	517	8	7810	685	13	10500	463	6	
FWD06AT	800	5320	929	15	6870	624	7	9040	793	11	12230	540	5	
	1000	6270	1091	20	8070	705	9	10630	933	14	14340	633	7	
	1250	7340	1279	27	9430	824	12	12450	1092	19	16750	739	9	
FWD08AT	1200	7310	1274	18	9420	823	8	12410	1089	13	16730	739	6	
	1400	8830	1541	25	10480	915	10	13830	1213	15	18610	821	7	
	1600	9690	1688	29	11470	1002	11	15150	1330	18	20370	899	9	
FWD10AT	1200	8250	1436	12	10680	933	5	14030	1230	8	19000	839	4	
	1400	9270	1614	15	11960	1045	7	15740	1381	10	21720	939	5	
	1600	10220	1781	17	13170	1151	8	17350	1523	12	23420	1034	6	
FWD12AT	1600	10860	1892	19	14040	1227	8	18440	1619	13	24980	1102	6	
	1900	12320	2146	23	15890	1388	10	20920	1835	16	28250	1247	8	
	2200	13690	2384	28	17610	1539	13	23220	2038	20	31310	1382	10	
FWD16AT	2000	13870	2416	21	18020	1574	10	23560	2067	15	32010	1414	7	
	2500	16390	2855	28	21320	1855	13	27820	2442	20	37710	1664	10	
	3000	18720	3260	35	24190	2113	16	31750	2787	25	42930	1896	12	
FWD18AT	2000	15060	2624	27	19710	1722	12	25610	2248	19	35030	1546	9	
	2500	17960	3129	36	23420	2047	17	30520	2677	26	41600	1837	13	
	3000	20650	3598	46	26870	2347	21	35060	3077	33	47700	2106	16	

4TW60222-1_B (Sheet 5/7)

5 Capacity tables

5 - 4 Capacity Correction Factor

FWD-AT/AF

	ESP (Pa)	0		20		40		60		80		100		120		140		160		180		200		220		240		
		Fan speed	F1	F2	F1	F2	F1	F2	F1	F2	F1	F2	F1	F2	F1	F2	F1	F2	F1	F2	F1	F2	F1	F2	F1	F2	F1	F2
FWD04AT/AF	Max.	1.18	1.13	1.13	1.09	1.08	1.06	1.02	1.02	0.96	0.97	0.89	0.92	0.80	0.85	0.70	0.77	0.53	0.62	-	-	-	-	-	-	-	-	-
	Med.	1.34	1.24	1.28	1.20	1.21	1.15	1.13	1.10	1.04	1.03	0.95	0.96	0.82	0.86	0.65	0.71	-	-	-	-	-	-	-	-	-	-	-
	Min.	1.44	1.34	1.37	1.29	1.29	1.23	1.20	1.16	1.10	1.08	0.97	0.98	0.79	0.82	-	-	-	-	-	-	-	-	-	-	-	-	-
FWD06AT/AF	Max.	1.26	1.19	1.18	1.13	1.09	1.07	0.99	0.99	0.88	0.91	0.75	0.81	0.60	0.68	0.40	0.48	-	-	-	-	-	-	-	-	-	-	-
	Med.	1.37	1.26	1.28	1.20	1.19	1.13	1.08	1.06	0.97	0.97	0.87	0.87	0.67	0.73	0.44	0.50	-	-	-	-	-	-	-	-	-	-	-
	Min.	1.47	1.34	1.38	1.28	1.28	1.21	1.17	1.13	1.04	1.03	0.90	0.92	0.72	0.77	0.45	0.50	-	-	-	-	-	-	-	-	-	-	-
FWD08AT/AF	Max.	1.28	1.20	1.21	1.15	1.13	1.09	1.04	1.03	0.94	0.96	0.83	0.88	0.71	0.77	0.55	0.63	0.30	0.36	-	-	-	-	-	-	-	-	-
	Med.	1.18	1.13	1.11	1.08	1.03	1.02	0.94	0.96	0.85	0.88	0.74	0.79	0.61	0.68	0.42	0.49	-	-	-	-	-	-	-	-	-	-	-
	Min.	1.15	1.11	1.08	1.06	1.00	1.00	0.91	0.93	0.82	0.85	0.70	0.75	0.56	0.62	0.35	0.41	-	-	-	-	-	-	-	-	-	-	-
FWD10AT/AF	Max.	1.26	1.20	1.18	1.14	1.10	1.08	1.02	1.02	0.92	0.94	0.82	0.85	0.70	0.74	0.54	0.60	0.31	0.38	-	-	-	-	-	-	-	-	-
	Med.	1.17	1.14	1.10	1.08	1.02	1.02	0.94	0.95	0.84	0.87	0.73	0.77	0.60	0.64	0.41	0.46	-	-	-	-	-	-	-	-	-	-	-
	Min.	1.14	1.12	1.07	1.06	0.99	0.99	0.91	0.92	0.81	0.83	0.70	0.72	0.56	0.57	0.35	0.43	-	-	-	-	-	-	-	-	-	-	-
FWD12AT/AF	Max.	1.35	1.24	1.29	1.21	1.22	1.16	1.15	1.11	1.07	1.06	0.99	0.99	0.89	0.92	0.77	0.82	0.61	0.68	-	-	-	-	-	-	-	-	-
	Med.	1.16	1.12	1.10	1.08	1.03	1.03	0.96	0.97	0.88	0.91	0.79	0.83	0.69	0.74	0.56	0.62	0.35	0.40	-	-	-	-	-	-	-	-	-
	Min.	1.02	1.02	0.96	0.97	0.89	0.91	0.82	0.85	0.74	0.78	0.65	0.70	0.54	0.59	0.39	0.43	-	-	-	-	-	-	-	-	-	-	-
FWD16AT/AF	Max.	1.13	1.10	1.12	1.09	1.10	1.07	1.08	1.06	1.06	1.05	1.04	1.04	1.03	1.02	1.01	1.01	0.98	0.99	0.96	0.98	0.94	0.96	0.92	0.94	0.89	0.92	0.91
	Med.	1.11	1.08	1.09	1.07	1.07	1.05	1.04	1.03	1.02	1.02	1.00	1.00	0.97	0.98	0.95	0.96	0.92	0.94	0.89	0.92	0.86	0.89	0.83	0.86	0.79	0.84	0.84
	Min.	1.09	1.07	1.06	1.05	1.03	1.03	1.01	1.01	0.98	0.99	0.95	0.96	0.92	0.94	0.89	0.91	0.86	0.88	0.82	0.85	0.78	0.82	0.74	0.78	0.69	0.74	0.74
FWD18AT/AF	Max.	1.12	1.09	1.11	1.08	1.09	1.06	1.07	1.05	1.05	1.04	1.03	1.03	1.01	1.01	0.99	1.00	0.97	0.98	0.95	0.97	0.93	0.95	0.91	0.93	0.88	0.91	0.91
	Med.	1.10	1.07	1.07	1.06	1.05	1.04	1.03	1.02	1.01	1.01	0.98	0.99	0.96	0.97	0.93	0.95	0.90	0.92	0.87	0.90	0.84	0.88	0.81	0.85	0.78	0.82	0.82
	Min.	1.08	1.06	1.05	1.04	1.03	1.02	1.00	1.00	0.97	0.98	0.94	0.95	0.91	0.93	0.88	0.90	0.84	0.87	0.81	0.84	0.77	0.81	0.72	0.77	0.67	0.72	0.72

NOTES

Conditions

Cooling

Heating 2-pipe

Heating 4-pipe

Air: 27°C DB - 19°C WB - Water: entering 7°C - leaving 12°C

Air: 20°C Water: entering 50°C water flow as for cooling

Air: 20°C Water: entering 70°C - leaving 60°C

F1 = correction factor for air flow

F2 = correction factor for capacities

The correction factor is applicable also for 4-pipe and heating mode because the differences are negligible.

4TW60228-1A

6 Power consumption

FWD-AT/AF

FWD04AT/AF	Max.		Med.		Min.	
	Power input	Current	Power input	Current	Power input	Current
(Pa)	(W)	(A)	(W)	(A)	(W)	(A)
0	234	0.954	173	0.740	130	0.568
10	228	0.946	169	0.740	122	0.550
20	221	0.940	165	0.731	120	0.530
30	211	0.912	161	0.720	117	0.525
40	203	0.890	157	0.702	114	0.514
50	196	0.857	148	0.655	112	0.496
60	182	0.792	144	0.633	109	0.485
70	173	0.754	140	0.616	107	0.473
80	166	0.710	132	0.573	104	0.456
90	158	0.671	125	0.545	100	0.444
100	153	0.639	120	0.520	95	0.419
120	141	0.594	112	0.477	85	0.375
140	130	0.542	97	0.428	77	0.327
160	115	0.471	-	-	-	-

SYMBOL

ESP: External static pressure

4TW60221-2_A

FWD-AT/AF

FWD06AT/AF	Max.		Med.		Min.	
	Power input	Current	Power input	Current	Power input	Current
(Pa)	(W)	(A)	(W)	(A)	(W)	(A)
0	349	1.575	294	1.389	247	1.183
10	329	1.530	275	1.322	238	1.150
20	317	1.490	263	1.287	230	1.120
30	303	1.470	256	1.246	225	1.092
40	295	1.430	246	1.194	218	1.065
50	286	1.380	237	1.159	210	1.036
60	274	1.340	228	1.115	204	1.001
70	264	1.306	218	1.078	199	0.974
80	256	1.265	212	1.038	187	0.933
90	246	1.220	200	0.986	180	0.885
100	235	1.170	191	0.951	170	0.849
110	224	1.130	183	0.910	159	0.791
120	212	1.090	167	0.841	145	0.730
130	192	1.010	154.0	0.790	136	0.691
140	178	0.967	140.0	0.725	120	0.623
150	161	0.905	126.0	0.688	114	0.598
160	152	0.880	-	-	-	-

SYMBOL

ESP: External static pressure

4TW60221-2_B

6 Power consumption

1
6

FWD-AT/AF

FWD08AT/AF	Max.		Med.		Min.	
	Power input	Current	Power input	Current	Power input	Current
(Pa)	(W)	(A)	(W)	(A)	(W)	(A)
0	443	1.971	336	1.515	261	1.204
10	420	1.915	317	1.475	247	1.186
20	404	1.850	301	1.418	238	1.144
30	382	1.808	290	1.366	231	1.106
40	367	1.715	279	1.330	221	1.045
52	353	1.670	262	1.246	212	1.008
60	335	1.582	251	1.189	203	0.972
70	315	1.508	248	1.163	195	0.935
80	302	1.430	233	1.109	186	0.885
90	280	1.350	221	1.045	176	0.839
100	267	1.292	210	0.994	168	0.804
110	254	1.224	198	0.936	155	0.741
120	238	1.166	185	0.889	146	0.705
130	225	1.106	172	0.826	135	0.648
140	203	1.028	155	0.746	126	0.605
150	193	0.970	142	0.682	118	0.576
160	174	0.897	-	-	-	-

SYMBOL

ESP: External static pressure

4TW60221-2_C

FWD-AT/AF

FWD10AT/AF	Max.		Med.		Min.	
	Power input	Current	Power input	Current	Power input	Current
(Pa)	(W)	(A)	(W)	(A)	(W)	(A)
0	443	1.971	336	1.515	261	1.204
10	420	1.915	317	1.475	247	1.186
20	404	1.850	301	1.418	238	1.144
30	382	1.808	290	1.366	231	1.106
40	367	1.715	279	1.330	221	1.045
52	353	1.670	262	1.246	212	1.008
60	335	1.582	251	1.189	203	0.972
70	315	1.508	248	1.163	195	0.935
80	302	1.430	233	1.109	186	0.885
90	280	1.350	221	1.045	176	0.839
100	267	1.292	210	0.994	168	0.804
110	254	1.224	198	0.936	155	0.741
120	238	1.166	185	0.889	146	0.705
130	225	1.106	172	0.826	135	0.648
140	203	1.028	155	0.746	126	0.605
150	193	0.970	142	0.682	118	0.576
160	174	0.897	-	-	-	-

SYMBOL

ESP: External static pressure

4TW60221-2_D

6 Power consumption

FWD-AT/AF

FWD12AT/AF	Max.		Med.		Min.	
	Power input	Current	Power input	Current	Power input	Current
(Pa)	(W)	(A)	(W)	(A)	(W)	(A)
0	714	3.210	473	2.080	328	1.500
10	683	3.100	452	2.070	309	1.485
20	663	3.070	440	2.060	303	1.460
30	646	3.020	430	2.040	299	1.438
40	630	2.990	420	1.970	290	1.403
50	620	2.950	415	1.915	287	1.382
60	604	2.895	402	1.900	278	1.338
70	580	2.800	390	1.860	272	1.306
80	570	2.730	380	1.790	267	1.280
90	550	2.650	370	1.730	257	1.236
100	530	2.600	350	1.650	252	1.213
110	520	2.540	340	1.600	249	1.190
120	490	2.450	330	1.540	244	1.173
130	480	2.390	320	1.480	239	1.139
140	450	2.300	310	1.440	235	1.118
150	440	2.225	300	1.380	230	1.100
160	430	2.210	-	-	-	-

SYMBOL

ESP: External static pressure

4TW60221-2_E

FWD-AT/AF

FWD16AT/AF	Max.		Med.		Min.	
	Power input	Current	Power input	Current	Power input	Current
(Pa)	(W)	(A)	(W)	(A)	(W)	(A)
0	1197	5.370	966	4.380	704	3.260
10	1159	5.300	921	4.200	680	3.250
20	1130	5.250	897	4.090	672	3.240
30	1112	5.200	879	4.046	660	3.200
40	1092	5.100	864	3.986	650	3.150
50	1086	5.090	848	3.930	640	3.080
60	1068	5.060	842	3.910	638	3.010
70	1060	5.020	830	3.883	629	2.990
80	1051	5.000	820	3.823	624	2.963
90	1050	4.960	810	3.774	620	2.958
100	1034	4.930	800	3.693	610	2.930
110	1026	4.900	790	3.620	600	2.870
120	1017	4.880	760	3.540	590	2.830
130	1006	4.850	743	3.480	580	2.790
140	997	4.820	730	3.420	570	2.740
150	985	4.790	717	3.400	556	2.690
160	973	4.760	710	3.350	540	2.600
170	963	4.690	703	3.300	532	2.566
180	944	4.620	680	3.200	520	2.470
190	926	4.550	661	3.133	-	-
200	912	4.493	655	3.120	-	-
210	894	4.405	-	-	-	-
220	877	4.313	-	-	-	-
230	860	4.215	-	-	-	-
240	848	4.150	-	-	-	-
250	841	4.117	-	-	-	-

SYMBOL

ESP: External static pressure

4TW60221-2_F

6 Power consumption

1
6

FWD-AT/AF

FWD18AT/AF	Max.		Med.		Min.	
	Power input	Current	Power input	Current	Power input	Current
(Pa)	(W)	(A)	(W)	(A)	(W)	(A)
0	1197	5.370	966	4.380	704	3.260
10	1159	5.300	921	4.200	680	3.250
20	1130	5.250	897	4.090	672	3.240
30	1112	5.200	879	4.046	660	3.200
40	1092	5.100	864	3.986	650	3.150
50	1086	5.090	848	3.930	640	3.080
60	1068	5.060	842	3.910	638	3.010
70	1060	5.020	830	3.883	629	2.990
80	1051	5.000	820	3.823	624	2.963
90	1050	4.960	810	3.774	620	2.958
100	1034	4.930	800	3.693	610	2.930
110	1026	4.900	790	3.620	600	2.870
120	1017	4.880	760	3.540	590	2.830
130	1006	4.850	743	3.480	580	2.790
140	997	4.820	730	3.420	570	2.740
150	985	4.790	717	3.400	556	2.690
160	973	4.760	710	3.350	540	2.600
170	963	4.690	703	3.300	532	2.566
180	944	4.620	680	3.200	520	2.470
190	926	4.550	661	3.133	-	-
200	912	4.493	655	3.120	-	-
210	894	4.405	-	-	-	-
220	877	4.313	-	-	-	-
230	860	4.215	-	-	-	-
240	848	4.150	-	-	-	-
250	841	4.117	-	-	-	-

SYMBOL

ESP: External static pressure

4TW60221-2_G

7 Dimensional drawings

7 - 1 Dimensional drawings

FWD04-06-08-10AT/AF

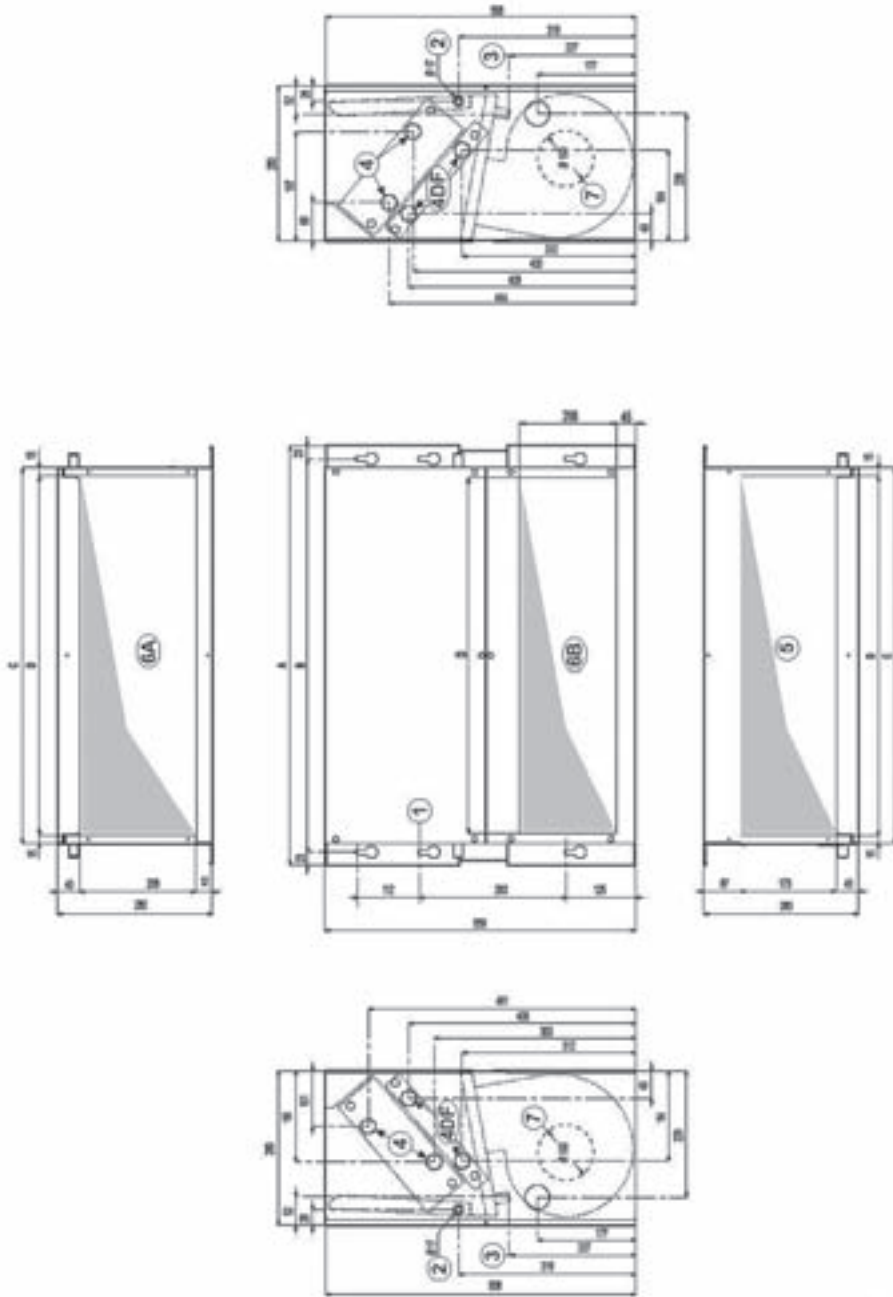

4TW60224-1A_A

NOTES

- 1 6 fast-coupling slots
- 2 Condensate drainage for horizontal installation
- 3 Condensate drainage for vertical installation
- 4 Hydraulic connections
4 = standard heat exchanger
4 DF = supplementary heat exchanger
- 5 Air delivery
- 6 Air intake
6A = supply terms
6B = changeable during installation
- 7 Round pre-sheared element (J 100 mm) for fresh air intake

FWD04AT/AF	FWD06AT/AF	FWD08AT/AF	FWD10AT/AF	FWD12AT/AF	FWD16AT/AF	FWD18AT/AF
3/4"	3/4"	3/4"	3/4"	1"	1"	1"

	A	B	C	D
FWD04AT/AF	754	707	676	646
FWD06AT/AF	964	917	886	856
FWD08+10AT/AF	1174	1127	1096	1066

7 Dimensional drawings

7 - 1 Dimensional drawings

FWD12-16-18AT/AF

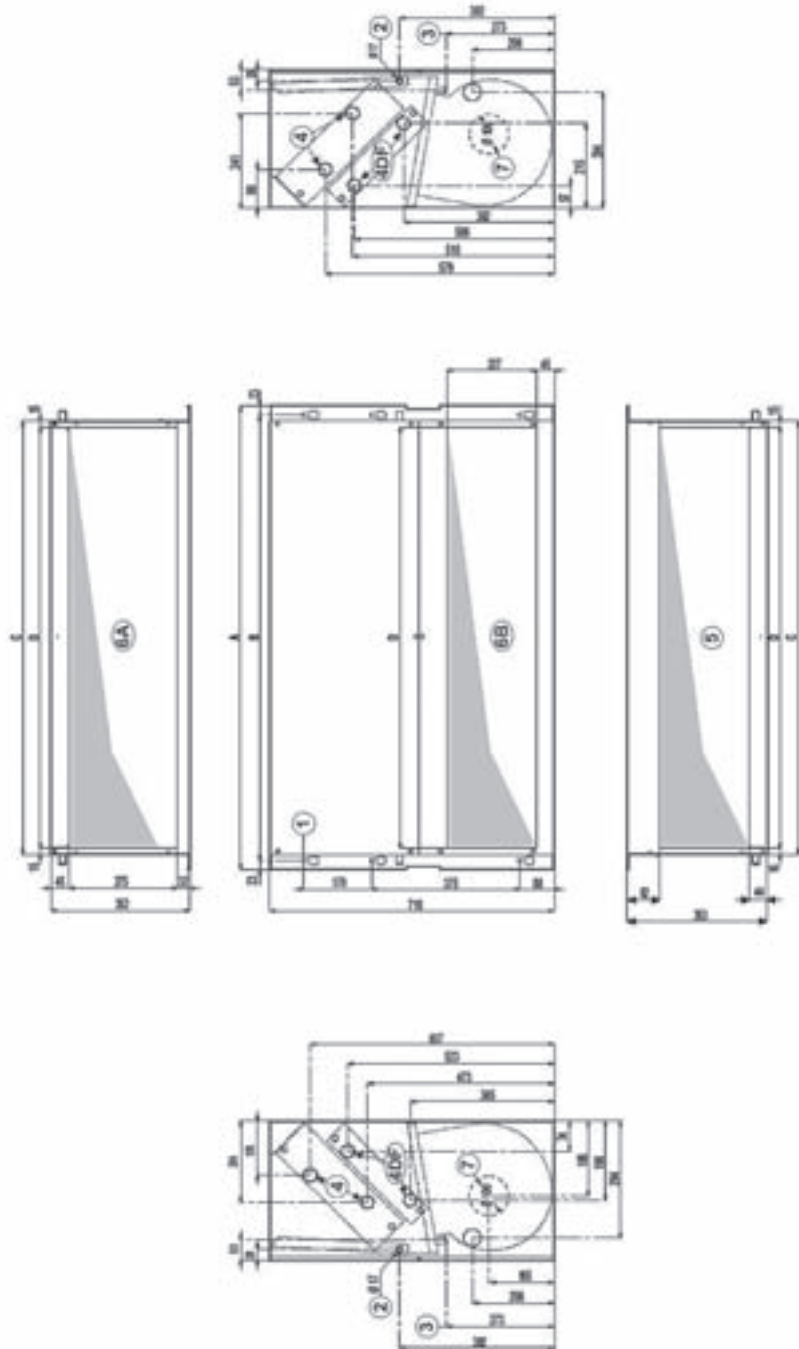

4TW60224-1A_B

NOTES

- 1 6 fast-coupling slots
- 2 Condensate drainage for horizontal installation
- 3 Condensate drainage for vertical installation
- 4 Hydraulic connections
4 = standard heat exchanger
4 DF = supplementary heat exchanger
- 5 Air delivery
- 6 Air intake
6A = supply terms
6B = changeable during installation
- 7 Round pre-sheared element (J 100 mm) for fresh air intake

FWD04AT/AF	FWD06AT/AF	FWD08AT/AF	FWD10AT/AF	FWD12AT/AF	FWD16AT/AF	FWD18AT/AF
3/4"	3/4"	3/4"	3/4"	1"	1"	1"

	A	B	C	D
FWD12AT/AF	1174	1127	1096	1066
FWD16+18AT/AF	1384	1337	1306	1276

8 Wiring diagrams

8 - 1 Wiring diagrams - Single Phase

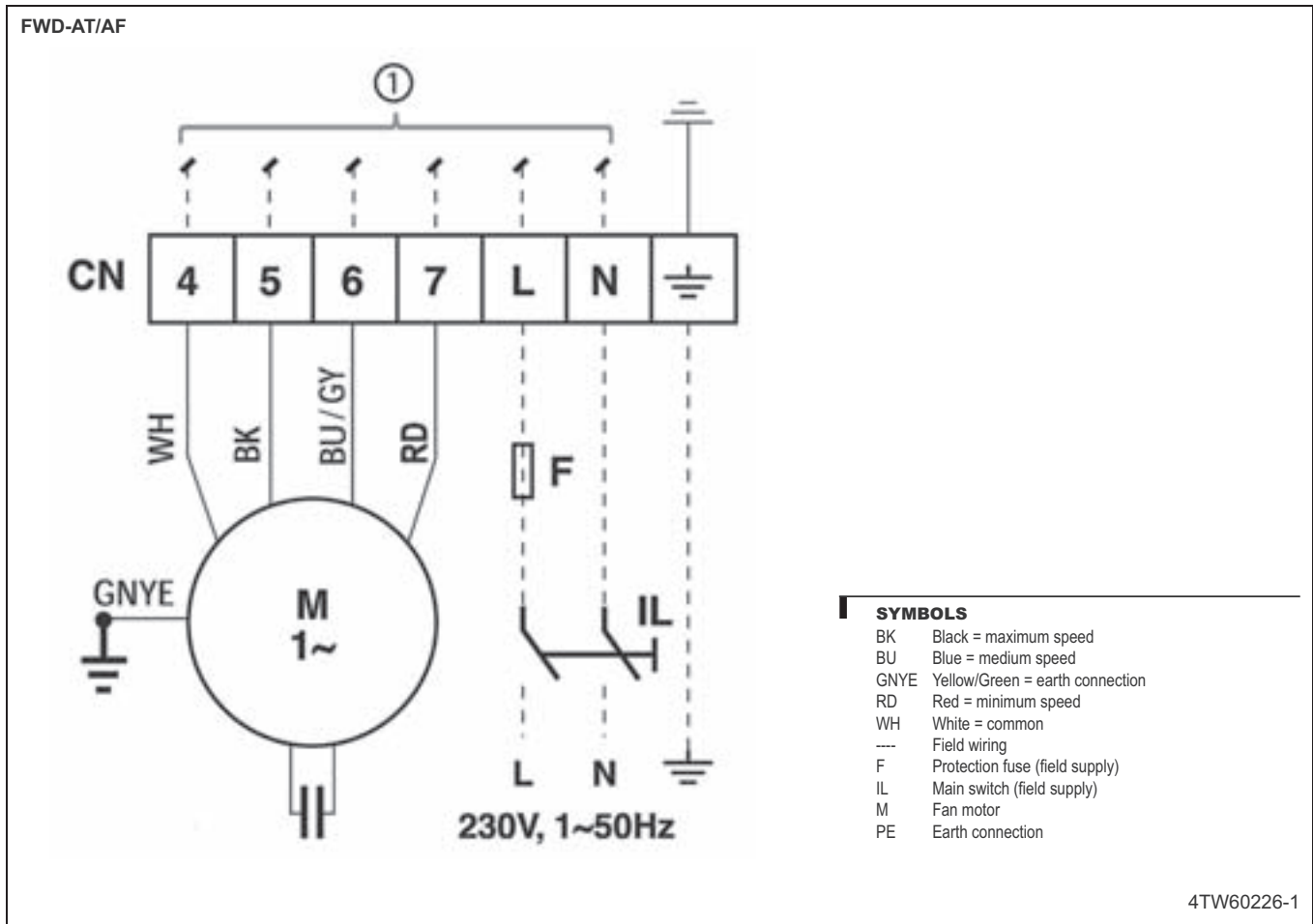

9 Sound data

9 - 1 Sound Level Data

1
9

FWD04AT/AF

FWD04AT/AF		125 Hz	250 Hz	500 Hz	1000 Hz	2000 Hz	4000 Hz	8000 Hz	Global Lw
Max.	L _w tot dB(A)	43.6	47.0	60.0	62.0	60.7	54.8	46.2	66
		125 Hz	250 Hz	500 Hz	1000 Hz	2000 Hz	4000 Hz	8000 Hz	
	Outlet	40.4	43.3	55.9	58.4	57.0	51.4	42.9	62.5
	Structure	29.3	38.5	53.6	53.0	52.1	43.8	34.3	58.0
	Inlet 57.8	40.4	43.3	55.9	58.4	57.0	51.4	42.9	62.5
Med.	L _w tot dB(A)	40.7	53.8	53.8	57.0	53.6	50.6	43.3	61
		125 Hz	250 Hz	500 Hz	1000 Hz	2000 Hz	4000 Hz	8000 Hz	
	Outlet	37.5	50.2	49.7	53.4	49.9	47.2	40.0	57.7
	Structure	26.4	45.3	47.4	47.9	45.0	39.6	31.5	52.9
	Inlet	37.5	50.2	49.7	53.4	49.9	47.2	40.0	57.7
Min.	L _w tot dB(A)	33.8	47.7	47.0	49.8	47.0	41.9	33.5	54
		125 Hz	250 Hz	500 Hz	1000 Hz	2000 Hz	4000 Hz	8000 Hz	
	Outlet	30.6	44.1	42.9	46.2	43.3	38.6	30.2	50.7
	Structure	19.5	39.2	40.6	40.8	38.4	30.9	21.6	46.0
	Inlet	30.6	44.1	42.9	46.2	43.3	38.6	30.2	50.7

NOTE

1. Sound power levels measured at ESP = 0 Pa.

4TW60227-1_A

FWD06AT/AF

FWD06AT/AF		125 Hz	250 Hz	500 Hz	1000 Hz	2000 Hz	4000 Hz	8000 Hz	Global Lw
Max.	L _w tot dB(A)	45.0	56.9	60.8	64.7	63.5	57.7	49.7	69
		125 Hz	250 Hz	500 Hz	1000 Hz	2000 Hz	4000 Hz	8000 Hz	
	Outlet	41.8	53.2	56.7	61.2	59.9	54.4	46.4	65.2
	Structure	30.7	48.3	54.4	55.7	55.0	46.7	37.8	60.3
	Inlet 57.8	41.8	53.2	56.7	61.2	59.9	54.4	46.4	65.2
Med.	L _w tot dB(A)	41.5	52.6	56.9	59.0	54.7	50.9	40.5	63
		125 Hz	250 Hz	500 Hz	1000 Hz	2000 Hz	4000 Hz	8000 Hz	
	Outlet	38.3	49.0	52.7	55.4	51.1	47.6	37.2	59.1
	Structure	27.2	44.1	50.4	50.0	46.2	39.9	28.7	54.6
	Inlet	38.3	49.0	52.7	55.4	51.1	47.6	37.2	59.1
Min.	L _w tot dB(A)	37.0	48.8	53.0	54.4	50.0	48.6	33.5	59
		125 Hz	250 Hz	500 Hz	1000 Hz	2000 Hz	4000 Hz	8000 Hz	
	Outlet	33.9	45.1	48.8	50.8	46.3	45.3	30.2	54.9
	Structure	22.8	40.3	46.5	45.3	41.4	37.6	21.6	50.4
	Inlet	33.9	45.1	48.8	50.8	46.3	45.3	30.2	54.9

NOTE

1. Sound power levels measured at ESP = 0 Pa.

4TW60227-1_B

9 Sound data

9 - 1 Sound Level Data

FWD08AT/AF

FWD08AT/AF		125 Hz	250 Hz	500 Hz	1000 Hz	2000 Hz	4000 Hz	8000 Hz	Global Lw
Max.	L _w tot dB(A)	50.7	62.1	64.8	68.1	66.5	62.5	56.2	72
		125 Hz	250 Hz	500 Hz	1000 Hz	2000 Hz	4000 Hz	8000 Hz	
	Outlet	47.5	58.4	60.7	64.5	62.8	59.1	52.9	68.9
	Structure	36.4	53.6	58.4	59.1	57.9	51.5	44.3	64.0
	Inlet 57.8	47.5	58.4	60.7	64.5	62.8	59.1	52.9	68.9
Med.	L _w tot dB(A)	45.0	57.5	60.1	62.5	58.9	56.4	49.2	67
		125 Hz	250 Hz	500 Hz	1000 Hz	2000 Hz	4000 Hz	8000 Hz	
	Outlet	41.8	53.8	56.0	58.9	55.3	53.0	45.9	63.0
	Structure	30.7	49.0	53.7	53.5	50.4	45.4	37.3	58.4
	Inlet	41.8	53.8	56.0	58.9	55.3	53.0	45.9	63.0
Min.	L _w tot dB(A)	40.5	53.4	55.9	57.5	54.3	50.3	42.4	62
		125 Hz	250 Hz	500 Hz	1000 Hz	2000 Hz	4000 Hz	8000 Hz	
	Outlet	37.4	49.7	51.8	53.9	50.6	46.9	39.1	58.2
	Structure	26.3	44.9	49.5	48.4	45.7	39.3	30.5	53.7
	Inlet	37.4	49.7	51.8	53.9	50.6	46.9	39.1	58.2

NOTE

1. Sound power levels measured at ESP = 0 Pa.

4TW60227-1_C

FWD10AT/AF

FWD10AT/AF		125 Hz	250 Hz	500 Hz	1000 Hz	2000 Hz	4000 Hz	8000 Hz	Global Lw
Max.	L _w tot dB(A)	50.7	62.1	64.8	68.1	66.5	62.5	56.2	72
		125 Hz	250 Hz	500 Hz	1000 Hz	2000 Hz	4000 Hz	8000 Hz	
	Outlet	47.5	58.4	60.7	64.5	62.8	59.1	52.9	68.9
	Structure	36.4	53.6	58.4	59.1	57.9	51.5	44.3	64.0
	Inlet 57.8	47.5	58.4	60.7	64.5	62.8	59.1	52.9	68.9
Med.	L _w tot dB(A)	45.0	57.5	60.1	62.5	58.9	56.4	49.2	67
		125 Hz	250 Hz	500 Hz	1000 Hz	2000 Hz	4000 Hz	8000 Hz	
	Outlet	41.8	53.8	56.0	58.9	55.3	53.0	45.9	63.0
	Structure	30.7	49.0	53.7	53.5	50.4	45.4	37.3	58.4
	Inlet	41.8	53.8	56.0	58.9	55.3	53.0	45.9	63.0
Min.	L _w tot dB(A)	40.5	53.4	55.9	57.5	54.3	50.3	42.4	62
		125 Hz	250 Hz	500 Hz	1000 Hz	2000 Hz	4000 Hz	8000 Hz	
	Outlet	37.4	49.7	51.8	53.9	50.6	46.9	39.1	58.2
	Structure	26.3	44.9	49.5	48.4	45.7	39.3	30.5	53.7
	Inlet	37.4	49.7	51.8	53.9	50.6	46.9	39.1	58.2

NOTE

1. Sound power levels measured at ESP = 0 Pa.

4TW60227-1_D

9 Sound data

9 - 1 Sound Level Data

1
9

FWD12AT/AF

FWD12AT/AF		125 Hz	250 Hz	500 Hz	1000 Hz	2000 Hz	4000 Hz	8000 Hz	Global Lw
Max.	L _w tot dB(A)	52.0	62.5	65.2	70.0	69.2	64.5	58.2	74
		125 Hz	250 Hz	500 Hz	1000 Hz	2000 Hz	4000 Hz	8000 Hz	
	Outlet	48.8	58.8	61.1	66.4	65.5	61.1	54.9	70.7
	Structure	37.7	54.0	58.8	61.0	60.6	53.5	46.3	65.7
	Inlet 57.8	48.8	58.8	61.1	66.4	65.5	61.1	54.9	70.7
Med.	L _w tot dB(A)	46.2	57.7	59.9	62.8	60.5	57.1	50.0	67
		125 Hz	250 Hz	500 Hz	1000 Hz	2000 Hz	4000 Hz	8000 Hz	
	Outlet	43.1	54.0	55.8	59.2	56.9	53.8	46.8	63.5
	Structure	32.0	49.2	53.5	53.8	52.0	46.1	38.2	58.8
	Inlet	43.1	54.0	55.8	59.2	56.9	53.8	46.8	63.5
Min.	L _w tot dB(A)	39.3	50.6	54.2	55.9	53.1	47.8	41.5	60
		125 Hz	250 Hz	500 Hz	1000 Hz	2000 Hz	4000 Hz	8000 Hz	
	Outlet	36.1	46.9	50.1	52.4	49.5	44.4	38.2	56.5
	Structure	25.0	42.1	47.8	46.9	44.6	36.8	29.6	52.0
	Inlet	36.1	46.9	50.1	52.4	49.5	44.4	38.2	56.5

NOTE

1. Sound power levels measured at ESP = 0 Pa.

4TW60227-1_D

FWD16AT/AF

FWD16AT/AF		125 Hz	250 Hz	500 Hz	1000 Hz	2000 Hz	4000 Hz	8000 Hz	Global Lw
Max.	L _w tot dB(A)	61.0	70.5	70.0	72.5	71.1	69.6	63.8	78
		125 Hz	250 Hz	500 Hz	1000 Hz	2000 Hz	4000 Hz	8000 Hz	
	Outlet	57.8	66.8	65.9	68.9	67.4	66.2	60.5	74.5
	Structure	46.7	62.0	63.6	63.5	62.5	58.6	51.9	69.4
	Inlet 57.8	57.8	66.8	65.9	68.9	67.4	66.2	60.5	74.5
Med.	L _w tot dB(A)	58.3	65.1	67.1	67.9	65.8	64.2	56.7	73
		125 Hz	250 Hz	500 Hz	1000 Hz	2000 Hz	4000 Hz	8000 Hz	
	Outlet	55.2	61.4	63.0	64.3	62.1	60.8	53.4	69.8
	Structure	44.1	56.5	60.7	58.9	57.2	53.2	44.8	65.0
	Inlet	55.2	61.4	63.0	64.3	62.1	60.8	53.4	69.8
Min.	L _w tot dB(A)	52.1	61.3	62.3	63.8	62.6	60.7	49.1	69
		125 Hz	250 Hz	500 Hz	1000 Hz	2000 Hz	4000 Hz	8000 Hz	
	Outlet	48.9	57.7	58.2	60.3	58.9	57.4	45.8	65.7
	Structure	37.8	52.8	55.9	54.8	54.0	49.7	37.2	60.9
	Inlet	48.9	57.7	58.2	60.3	58.9	57.4	45.8	65.7

NOTE

1. Sound power levels measured at ESP = 0 Pa.

4TW60227-1_F

9 Sound data

9 - 1 Sound Level Data

FWD18AT/AF									
FWD18AT/AF		125 Hz	250 Hz	500 Hz	1000 Hz	2000 Hz	4000 Hz	8000 Hz	Global Lw
Max.	Lw tot dB(A)	61.0	70.5	70.0	72.5	71.1	69.6	63.8	78
		125 Hz	250 Hz	500 Hz	1000 Hz	2000 Hz	4000 Hz	8000 Hz	
	Outlet	57.8	66.8	65.9	68.9	67.4	66.2	60.5	74.5
	Structure	46.7	62.0	63.6	63.5	62.5	58.6	51.9	69.4
	Inlet 57.8	66.8	65.9	68.9	67.4	66.2	60.5	74.5	
Med.	Lw tot dB(A)	58.3	65.1	67.1	67.9	65.8	64.2	56.7	73
		125 Hz	250 Hz	500 Hz	1000 Hz	2000 Hz	4000 Hz	8000 Hz	
	Outlet	55.2	61.4	63.0	64.3	62.1	60.8	53.4	69.8
	Structure	44.1	56.5	60.7	58.9	57.2	53.2	44.8	65.0
	Inlet	55.2	61.4	63.0	64.3	62.1	60.8	53.4	69.8
Min.	Lw tot dB(A)	52.1	61.3	62.3	63.8	62.6	60.7	49.1	69
		125 Hz	250 Hz	500 Hz	1000 Hz	2000 Hz	4000 Hz	8000 Hz	
	Outlet	48.9	57.7	58.2	60.3	58.9	57.4	45.8	65.7
	Structure	37.8	52.8	55.9	54.8	54.0	49.7	37.2	60.9
	Inlet	48.9	57.7	58.2	60.3	58.9	57.4	45.8	65.7

NOTE
1. Sound power levels measured at ESP = 0 Pa.

4TW60227-1

10 Installation

10 - 1 Installation Method

FWD-AT/AF

BEFORE THE INSTALLATION

The equipment is to be installed and serviced exclusively by technical personnel who are qualified for using this type of machine, in compliance with the relevant local and national regulations.

On receiving the equipment, check its state ensuring that it was not damaged during transport. Refer to the associated technical sheets for the installation and use instructions of any accessories.

INTENDED CONDITIONS OF USE AND OPERATING LIMITS

No responsibility is assumed if the equipment is installed by unqualified personnel, if it is used improperly or under inadmissible conditions, if maintenance is not performed as envisaged in this manual or if original spare parts are not used. For the operating limits please refer to the appropriate chapter. Any other use is considered improper.

Keep the equipment inside the packing until it is ready to be installed so that dust will not infiltrate.

Air sucked by the equipment must always be filtered. Use, when possible, the specific accessories.

If not used during the winter, drain the water from the system to prevent damage caused by the formation of ice. If antifreeze solutions are used, check the freezing point.

Do not change the internal wiring or other parts of the equipment.

INSTALLATION WARNING:

On the fan coil unit install a switch (IL) and/or all remote controls in a position out of the reach of persons who are in a bathtub or shower.

The FWD units may be installed either in horizontal or vertical position. Check that the desired installation complies with one of the diagrams shown in the installation manual, in which both possible configurations, M or AB, are suitable to work for heating and cooling.

AA (INTAKE IN LINE - DELIVERY IN LINE)

AB (AIR SUCTION AT 90° - AIR OUTLET IN LINE)

CONFIGURATION of the unit

The units are always supplied in AA configuration, but the air intake position may be changed during the installation.

FIXING the unit

Fix the standard unit to the ceiling or wall using at least 4 of the 6 slots.;

For horizontal installations (ceiling-mounting) it is advisable to use M8 threaded bars, screw anchors suitable for the machine's weight, and to arrange for the positioning of the machine using 2 M8 bolts and a washer the diameter of which is suitable for.

Before tightening the check nut, adjust the closing of the main nut so that the equipment will slant correctly, i.e. for facilitating the discharging of the condensate.

The correct slant is achieved by tilting the intake downwards as compared to the delivery, until a difference in level of about 10 mm is obtained from one end to the other. Make the hydraulic connections with the heat exchanger and, for cooling operations, with the condensate discharge.

Use one of the two drains of the auxiliary tank, visible on the outside of the unit's side panels and vertical condensate discharge.

For vertical installations (wall-mounting), fix the unit so that water may flow out toward the condensate discharge used. A slant equivalent to a difference in level of about 5 mm is enough between the two side panels. The two condensate discharge tubes of the main tank are located inside the side panels and may be accessed through a membrane type passage that should be perforated for passing the discharge tube through it. It is advisable not to remove the aforesaid passage because it prevents the sharp edge of the hole on the side panel from damaging the condensate discharge tube over time.

To connect the unit to the condensate discharge line, use a flexible rubber tube and fix it to the chosen discharge tube (φ 3/8) by means of a metal clamp (use the discharge that is located on the hydraulic attachments side). To assist the draining of the condensate, slant the discharge tube downwards by at least 30 mm/m making sure that its entire route is clear and free from bends or blockages.

A few rules to follow

Carry out the heat exchanger's air exhaust, with pumps stopped, by means of the air valves located adjacent to the attachments of the heat exchanger itself.

4TW60229-3_A

10 Installation

10 - 1 Installation Method

FWD-AT/AF

When implementing a duct system, it is advisable to place the vibration-damping joints between the ducting and the unit. If you wish to install an electrical resistance module as accessory, the delivery vibration-damping joint should be heat-resistant. The ducting, especially the delivery one, should be insulated with anticondensing material.

Provide an inspection panel adjacent to the equipment for the maintenance and cleaning operations.

Install the control panel on the wall. Choose a position that is easy to access for the setting of the functions and, if contemplated, for the reading of the temperature. Try to avoid positions that are directly exposed to sun rays, or positions subject to direct hot or cold air currents, and do not place obstacles in the way that would prevent the correct reading of the temperature.

ELECTRICAL CONNECTIONS

Carry out the electrical wiring after having turned the power off in compliance with the relevant local and national regulations following the relevant wiring diagram.

Only qualified personnel should carry out the wiring operations.

Each fan coil requires a switch (IL) on the feeder line with a distance of at least 3 mm between the opening contacts, and a suitable safety fuse (F).

Power consumption is shown on the data plate fixed to the unit. Make sure to carefully execute the wiring in function of the combination unit/controller and this according to the correct wiring diagram delivered with every accessory. In order to make the electrical connections you must remove the lower closing panel to access the terminal board. The power cables (power supply and control) must be routed to the terminal board through the membrane passage that is on the side panel of the machine on the side opposite the hydraulic attachments.

WARNING

The COMMON wire of the motor is the WHITE one: if connected incorrectly the motor would be damaged irreparably.

FUNCTIONAL CHECKS

Check that the equipment has been installed so that it guarantees the required slant.

Check that the condensate discharge is not clogged (by rubble deposits, etc.).

Check the seal of the hydraulic connections.

Check that all the wirings are tight (perform the check with voltage OFF).

Make sure air has been purged from the heat exchanger.

Power the equipment and check its working efficiency.

10 Installation

10 - 1 Installation Method

FWD-AT/AF

1. Ducted unit with filter only

Consider at least:

- 500 mm free space on water connections side (piping & connections)
- 200 mm free space on the opposite side (to unscrew heat exchangers or fan deck in case of repairing)
- Possibility to extract filter for cleaning has to be considered
- Possibility to reach the unit for ordinary and extraordinary maintenance (for instance removing front panels) has to be considered
- 4TW60229

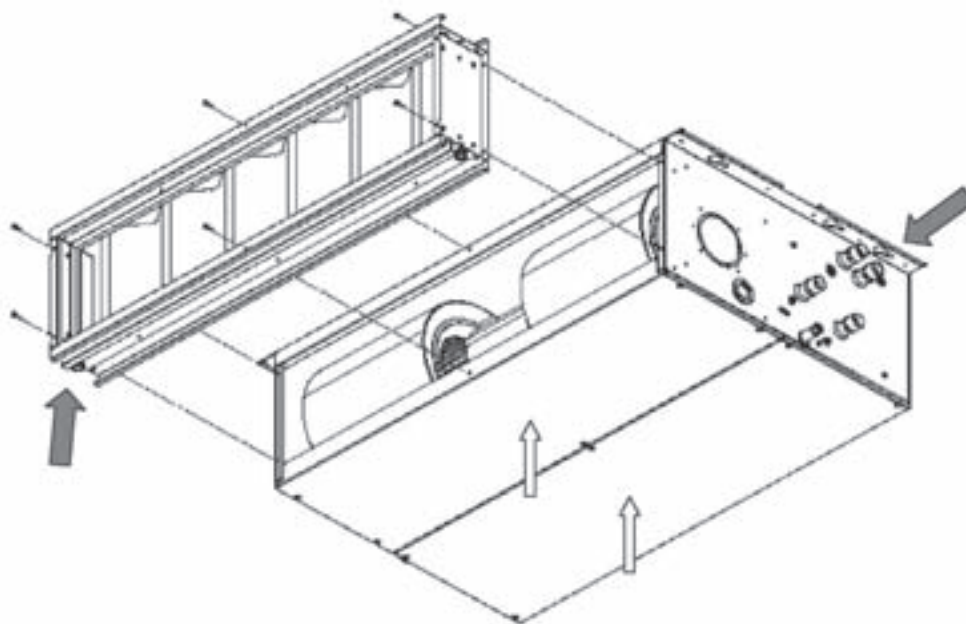

1

10

10 Installation

10 - 1 Installation Method

FWD-AT/AF

2. Ducted unit with filter and electric heater

Consider at least:

- 500 mm free space on water connections side (piping & connections), measured from the electrical box of the heating module (refer to option technical leaflet for details - total 620 mm)
- 200 mm free space on the opposite side (to unscrew heat exchangers or fan deck in case of repairing)
- Possibility to extract filter for cleaning has to be considered
- Possibility to reach the unit for ordinary and extraordinary maintenance (for instance removing front panels) has to be considered

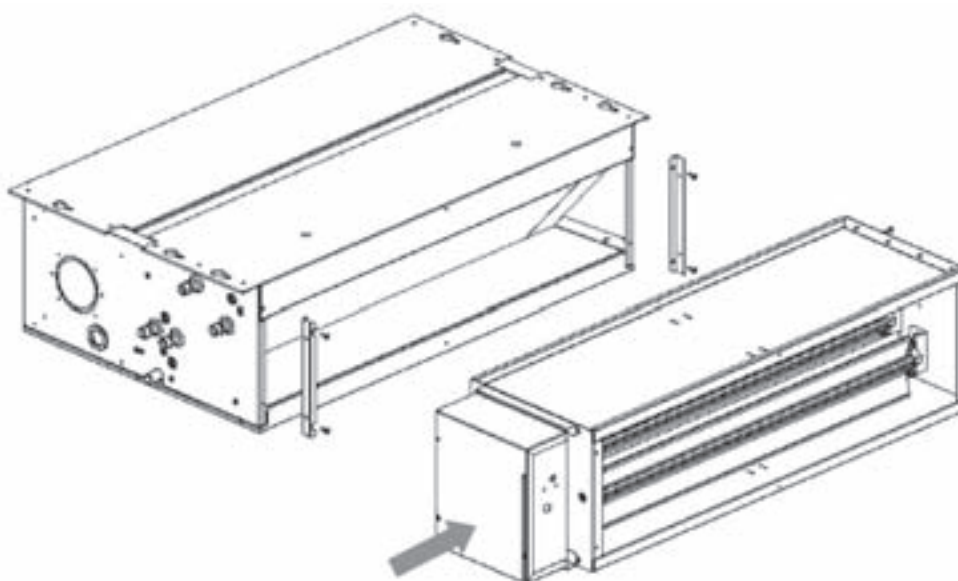

10 Installation

10 - 1 Installation Method

FWD-AT/AF

3. Ducted unit with filter and valves

Consider also:

- 500 mm free space on water connections side (piping & connections), measured from the valve piping (refer to option technical leaflet for details - total around 720 mm)
- 200 mm free space on the opposite side (to unscrew heat exchangers or fan deck in case of repairing)
- Possibility to extract filter for cleaning has to be considered
- Possibility to reach the unit for ordinary and extraordinary maintenance (for instance removing front panels) has to be considered

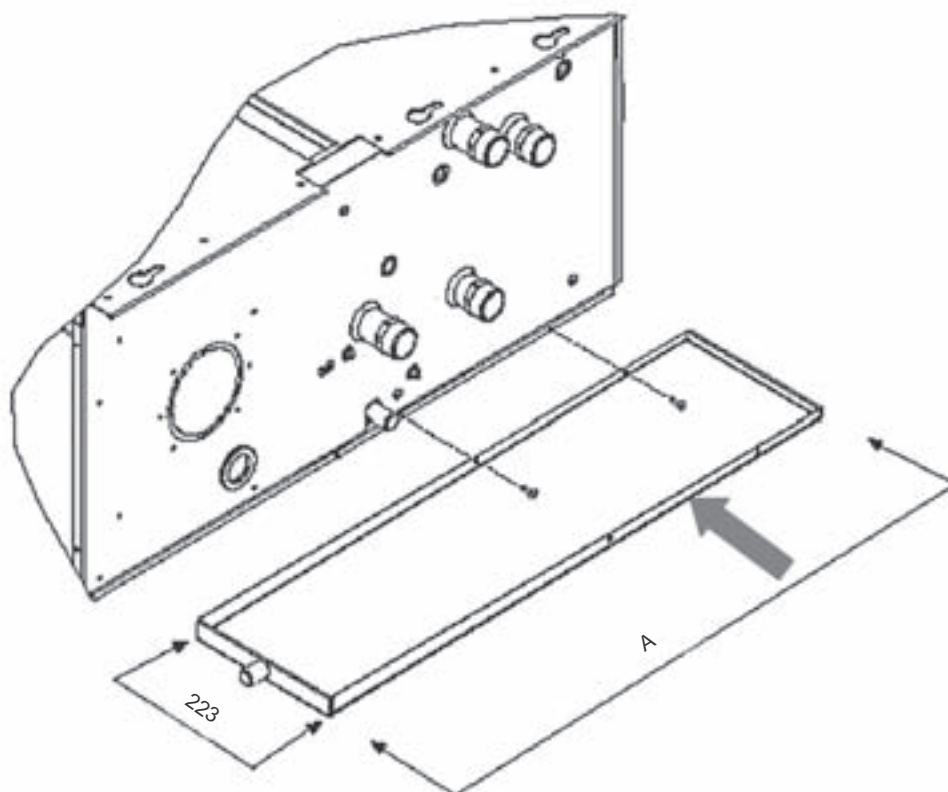

4TW60229-3_E

11 Operation range

11 - 1 Operation range

FWD-AT/AF

Minimum water temperature	+5°C
Maximum water temperature	+95°C
Maximum operating pressure	10 bar
Minimum air inlet temperature	-20°C
Maximum air inlet temperature	+43°C
Power supply	230V +10% / 1~ / 50Hz

4TW60223-1

12 Hydraulic performance

12 - 1 Water Pressure Drop Curve Evaporator

1
12

FWD-AT/AF

Water flow l/h	FWD-AT/AF						
	Water pressure drop						
	FWD04AT/AF	FWD06AT/AF	FWD08AT/AF	FWD10AT/AF	FWD12AT/AF	FWD16AT/AF	FWD18AT/AF
	kPa	kPa	kPa	kPa	kPa	kPa	kPa
100	0.59	0.37	0.25	0.13	0.13	0.09	0.1
200	2.02	1.25	0.84	0.45	0.43	0.32	0.35
300	4.12	2.57	1.72	0.92	0.88	0.65	0.71
400	6.83	4.27	2.86	1.53	1.47	1.08	1.19
500	10.12	6.32	4.24	2.27	2.19	1.6	1.76
600	13.94	8.71	5.85	3.14	3.02	2.22	2.44
700	18.28	11.42	7.67	4.12	3.97	2.92	3.2
800	23.12	14.45	9.69	5.21	5.02	3.69	4.06
900	28.45	17.77	11.92	6.41	6.17	4.55	5
1000	34.23	21.39	14.35	7.71	7.43	5.48	6.02
1100	40.48	25.29	16.97	9.11	8.79	6.47	7.11
1200	47.17	29.48	19.78	10.62	10.24	7.54	8.29
1300	54.29	33.94	22.77	12.23	11.78	8.68	9.54
1400	61.84	38.66	25.94	13.93	13.42	9.89	10.87
1500	69.81	43.65	29.28	15.73	15.16	11.16	12.27
1600	78.19	48.9	32.8	17.62	16.98	12.5	13.75
1700	86.97	54.4	36.5	19.6	18.89	13.91	15.3
1800	96.15	60.15	40.36	21.67	20.89	15.38	16.92
1900	105.73	66.15	44.38	23.83	22.97	16.92	18.61
2000	-	72.39	48.57	26.08	25.14	18.52	20.37
2100	-	78.88	52.93	28.42	27.4	20.18	22.19
2200	-	85.6	57.44	30.84	29.73	21.9	24.09
2300	-	92.55	62.11	33.35	32.15	23.68	26.05
2400	-	99.74	66.93	35.94	34.65	25.53	28.08
2500	-	107.16	71.91	38.62	37.23	27.43	30.17
3000	-	-	99.07	53.21	51.3	37.8	41.59
4000	-	-	-	88.2	85.07	62.71	69
5000	-	-	-	-	-	92.83	102.16

4TW60229-1_A

FWD-AT/AF

Water flow l/h	FWD-AT/AF						
	Water pressure drop						
	FWD04AT/AF	FWD06AT/AF	FWD08AT/AF	FWD10AT/AF	FWD12AT/AF	FWD16AT/AF	FWD18AT/AF
	kPa	kPa	kPa	kPa	kPa	kPa	kPa
100	0.51	0.32	0.22	0.12	0.11	0.08	0.09
200	1.68	1.07	0.72	0.39	0.38	0.28	0.31
300	3.4	2.16	1.46	0.78	0.76	0.56	0.62
400	5.6	3.56	2.4	1.29	1.25	0.93	1.03
500	8.25	5.24	3.53	1.9	1.84	1.37	1.51
600	11.33	7.18	4.84	2.61	2.53	1.88	2.07
700	14.81	9.39	6.32	3.4	3.3	2.45	2.71
800	18.69	11.83	7.97	4.29	4.16	3.09	3.41
900	22.95	14.52	9.77	5.26	5.1	3.79	4.18
1000	27.57	17.43	11.73	6.32	6.12	4.55	5.02
1100	32.55	20.57	13.85	7.46	7.22	5.36	5.91
1200	37.89	23.94	16.11	8.67	8.4	6.23	6.88
1300	43.56	27.51	18.51	9.97	9.65	7.14	7.9
1400	49.58	31.3	21.06	11.34	10.97	8.14	8.98
1500	55.92	35.29	23.74	12.78	12.37	9.17	10.12
1600	62.58	39.49	26.57	14.3	13.84	10.26	11.32
1700	69.57	43.89	29.52	15.89	15.37	11.4	12.57
1800	76.87	48.49	32.61	17.55	16.98	12.59	13.88
1900	84.48	53.28	35.83	19.28	18.65	13.83	15.24
2000	92.4	58.26	39.18	21.09	20.39	15.12	16.66
2100	100.61	63.43	42.66	22.95	22.2	16.45	18.14
2200	109.13	68.79	46.26	24.89	24.07	17.84	19.66
2300	-	74.34	49.99	26.9	26.01	19.27	21.24
2400	-	80.07	53.84	28.97	28.01	20.75	22.87
2500	-	85.97	57.81	31.1	30.08	22.28	24.55
3000	-	118.18	79.46	42.74	41.32	30.59	33.71
4000	-	-	-	70.61	68.24	50.5	55.63
5000	-	-	-	104.24	100.72	74.51	82.08

4TW60229-1_B

12 Hydraulic performance

12 - 1 Water Pressure Drop Curve Evaporator

FWD-AT/AF							
Water flow l/h	FWD-AT/AF						
	Water pressure drop						
	FWD04AT/AF	FWD06AT/AF	FWD08AT/AF	FWD10AT/AF	FWD12AT/AF	FWD16AT/AF	FWD18AT/AF
	kPa	kPa	kPa	kPa	kPa	kPa	kPa
100	0.83	0.71	0.35	0.35	0.13	0.1	0.1
200	2.75	2.36	1.16	1.16	0.42	0.33	0.33
300	5.55	4.76	2.34	2.34	0.85	0.67	0.67
400	9.14	7.84	3.84	3.84	1.39	1.1	1.1
500	13.48	11.54	5.65	5.65	2.05	1.61	1.61
600	18.51	15.83	7.75	7.75	2.81	2.21	2.21
700	24.21	20.7	10.13	10.13	3.66	2.88	2.88
800	30.56	26.1	12.77	12.77	4.62	3.63	3.63
900	37.52	32.04	15.68	15.68	5.66	4.45	4.45
1000	45.09	38.49	18.83	18.83	6.8	5.34	5.34
1100	53.25	45.44	22.22	22.22	8.02	6.29	6.29
1200	61.98	52.88	25.85	25.85	9.33	7.32	7.32
1300	71.27	60.8	29.72	29.72	10.72	8.41	8.41
1400	81.11	69.18	33.81	33.81	12.19	9.56	9.56
1500	91.5	78.03	38.13	38.13	13.74	10.78	10.78
1600	102.41	87.32	42.67	42.67	15.37	12.06	12.06
1700	-	97.06	47.42	47.42	17.08	13.39	13.39
1800	-	107.24	52.39	52.39	18.87	14.79	14.79
1900	-	-	57.57	57.57	20.73	16.25	16.25
2000	-	-	62.96	62.96	22.67	17.76	17.76
2500	-	-	92.92	92.92	33.44	26.19	26.19
3000	-	-	-	-	45.95	35.98	35.98
3500	-	-	-	-	60.12	47.06	47.06
4000	-	-	-	-	75.89	59.4	59.4
4500	-	-	-	-	93.21	72.95	72.95
5000	-	-	-	-	112.04	87.67	87.67

4TW60229-1_C

TABLE OF CONTENTS

FWD-AF

1	Specifications	2
	Technical Specifications	2
	Electrical Specifications	2
2	Electrical data	3
	Electrical data	3
3	Options	4
	Options	4
4	Control systems	5
	Control systems	5
5	Capacity tables	6
	Cooling Capacity Tables	6
	Cooling Capacity Tables Glycol 40 %	8
	Heating Capacity Tables	9
	Capacity Correction Factor	10
6	Power Consumption	11
7	Dimensional drawings	15
	Dimensional drawings	15
8	Wiring diagrams	17
	Wiring diagrams - Single Phase	17
9	Sound data	18
	Sound Level Data	18
10	Installation	22
	Installation Method	22
11	Operation range	27
	Operation range	27
12	Hydraulic performance	28
	Water Pressure Drop Curve Evaporator	28

1 Specifications

2
1

1-1 Technical Specifications				FWD04AF	FWD06AF	FWD08AF	FWD10AF	FWD12AF	FWD16AF	FWD18AF	
Cooling capacity	Total capacity	High	kW	3.90 (1)	6.20 (1)	7.80 (1)	8.82 (1)	11.90 (1)	16.40 (1)	18.30 (1)	
	Sensible capacity	High	kW	3.08 (1)	4.65 (1)	6.52 (1)	7.16 (1)	9.36 (1)	12.80 (1)	14.10 (1)	
Heating capacity	4-Pipe	High	kW	4.49 (2)	6.62 (2)	9.21 (2)		15.86 (2)	21.15 (2)		
Power input	High		W	234	349	443		714	1,197		
	Low		W	130	247	261		328	704		
	Nom.		W	173	294	336		473	966		
Casing	Colour	Not painted (galvanised)									
	Material	Galvanised sheet metal									
Dimensions	Unit	Height	mm	280				352			
		Width	mm	754	964	1,174			1,384		
		Depth	mm	559				718			
Weight	Unit	kg	35	43	50	52	71	83	86		
Heat exchanger	Rows	Quantity	3			4		3	4	5	
	Stages	Quantity	10				14				
	Fin pitch	mm	2.1	1.8	2.1						
	Face area	m ²	0.138	0.190	0.243			0.340	0.414		
	Water volume	l	1.06	1.42	1.79	2.38	2.50	4.02	5.03		
Additional heat exchanger	Rows	Quantity	1				2				
	Stages	Quantity	10				12				
	Fin pitch	mm	1.8				2.1				
	Face area	m ²	0.138	0.190	0.243			0.340	0.414		
	Water volume	l	0.35	0.47	0.59			1.42	1.72		
Water flow	Cooling	l/h	674	1,064	1,339	1,514	2,056	2,833	3,140		
	Heating	l/h	349	581	808		1,392	1,856			
Water pressure drop	Cooling	kPa	17	24		16		26	34	45	
	Heating	kPa	9	15	13		12	16			
Fan	Type	Centrifugal multi-blade, double suction									
	Quantity		1	2							
	Air flow rate	High	m ³ /h	800	1,250	1,600		2,200	3,000		
	Available pressure	High	Pa	63	53	63	59	92	138	128	
Fan motor	Speed	Steps	3 (high, medium, low)								
	Model	Closed induction, B class insulation, winding thermal cut-out									
Sound power level	High	dB(A)	66	69	72		74	78			
	Nom.	dB(A)	61	63	67			73			
	Low	dB(A)	54	59	62		60	69			
Piping connections	Drain	OD	mm								16
Insulation material	Class 1 self-extinguishing										
Vibration insulation	Rubber ring for fan motor										
Air filter	Acrylic - Filtering class EU2										
Water connections	Std. heat exchanger	inch	3/4					1			

1-2 Electrical Specifications				FWD04AF	FWD06AF	FWD08AF	FWD10AF	FWD12AF	FWD16AF	FWD18AF	
Power supply	Phase	1~									
	Frequency	Hz	50								
	Voltage	V	230								
Current input	High	A	0.95	1.58	1.97		3.21	5.37			
	Medium	A	0.74	1.39	1.52		2.08	4.38			
	Low	A	0.57	1.18	1.20		1.50	3.26			
Required wire section		mm ²	1		1.5		2	2.5			
Required fuses		A	2			4			6		

Notes

- (1) Rating conditions 4-pipe: air 27°CDB - 19°CWB - entering water 7°C - leaving water 12°C at nominal air flow and ESP
- (2) Rating conditions 4-pipe: air 20°CDB - entering water 70°C - leaving water 60°C at nominal air flow and ESP
- (3) Maximum Power input at 0Pa ESP
- (4) Sound level at 0Pa ESP
- (5) Current input at 0Pa ESP

2 Electrical data

2 - 1 Electrical data

FWD-AT/AF

FWD-AT/AF		Power input electric heater	Current Absorption	Power supply
Unit	Electric heater	kW	A	V / ~ / Hz
FWD04AT/AF	EDEHS04A6	2.0	8.7	230V +- 10% / 1~/50Hz
FWD06AT/AF	EDEHS06A6	3.0	4.3	400V +- 10% / 3~/50Hz
	EDEHB06A6	6.0	8.7	
FWD08AT/AF	EDEHS10A6	4.5	6.5	400V +- 10% / 3~/50Hz
	EDEHB10A6	9.0	13.0	
FWD10AT/AF	EDEHS10A6	4.5	6.5	400V +- 10% / 3~/50Hz
	EDEHB10A6	9.0	13.0	
FWD12AT/AF	EDEHS12A6	4.5	6.5	400V +- 10% / 3~/50Hz
	EDEHB12A6	9.0	13.0	
FWD16AT/AF	EDEHS18A6	9.0	13.0	400V +- 10% / 3~/50Hz
	EDEHB18A6	12.0	17.3	
FWD18AT/AF	EDEHS18A6	9.0	13.0	400V +- 10% / 3~/50Hz
	EDEHB18A6	12.0	17.3	

4TW60221-3

2

2

3 Options

3 - 1 Options

2
3

FWD-AT/AF										
	FWD-AT/AF	04	06	08	10	12	16	18	Notes/remarks	
Electric heater	EDEH(S)(B)..A6	EDEH04A6	EDEH(S)(B)06A6	EDEH(S)(B)10A6		EDEH(S)(B)12A6	EDEH(S)(B)18A6		Requires electronic Controller	
2-pipe ON-OFF 3 way motor driven valve complete with mounting kit	ED2MV..A6	ED2MV04A6	ED2MV10A6			ED2MV12A6	ED2MV18A6		For FWD 12 16 18 only motor valve (piping not included)	
4-pipe ON-OFF 3 way motor driven valve complete with mounting kit	ED4MV..A6	ED4MV04A6	ED4MV10A6			2 x ED2MV12A6	2 x ED2MV18A6		For FWD 12 16 18 only motor valve (piping not included)	
Fan stop thermostat	YFSTA6	YFSTA6								
Motorised fresh air intake louvers	EDMFA..A6	EDMFA04A6	EDMFA06A6	EDMFA10A6		EDMFA12A6	EDMFA18A6			
Auxiliary drain pan (vertical models)	EDDPV..A6	EDDPV10A6				EDDPV18A6				
Fcu Controller - Standard version	FWEC1A	FWEC1A								water probe included
Fcu Controller - Advanced version	FWEC2A	FWEC2A								water probe included
Fcu Controller - Advanced plus version	FWEC3A	FWEC3A								water probe included
Fcu temperature sensor kit	FWTSKA	FWTSKA								
Fcu relative humidity sensor kit	FWHSKA	FWHSKA								
Power interface	EPIB6	EPIB6								
Master slave for connection of up to 4 units	EPIMSB6	EPIMSB6								

4TW60229-2B(1)

FWD-AT/AF														
Description	Electric heater	2-pipe ON-OFF 3 way motor driven valve complete with mounting kit	4-pipe ON-OFF 3 way motor driven valve complete with mounting kit	Fan stop thermostat	Motorised fresh air intake louvers	Auxiliary drain pan (horizontal models)	Auxiliary drain pan (vertical models)	Fcu Controller - Standard version	Fcu Controller - Advanced version	Fcu Controller - Advanced plus version	Fcu temperature sensor kit	Fcu relative humidity sensor kit	Power interface	Master slave for connection of up to 4 units
	EDEH(S)(B)..A6	ED2MV..A6	ED4MV..A6	YFSTA6	EDMFA..A6	EDDPH..A6	EDDPV..A6	FWEC1A	FWEC2A	FWEC3A	FWTSKA	FWHSKA	EPIB6	EPIMSB6
Electric heater	X				X	X	X	X	X	X	X	X	X	X
2-pipe ON-OFF 3 way motor driven valve complete with mounting kit	X	X			X	X	X	X	X	X	X	X	X	X
4-pipe ON-OFF 3 way motor driven valve complete with mounting kit			X		X	X	X	X	X	X	X	X	X	X
Fan stop thermostat				X	X	X							X	X
Motorised fresh air intake louvers	X	X	X	X		X	X	X	X	X	X	X	X	X
Auxiliary drain pan (horizontal models)	X	X	X	X	X			X	X	X	X	X	X	X
Auxiliary drain pan (vertical models)	X	X	X	X	X			X	X	X	X	X	X	X
Fcu Controller - Standard version	X	X	X		X	X	X				X		X*	X*
Fcu Controller - Advanced version	X	X	X		X	X	X				X		X*	X*
Fcu Controller - Advanced plus version	X	X	X		X	X	X				X		X*	X*
Fcu temperature sensor kit	X	X	X		X	X	X	X	X	X		X	X	X
Fcu relative humidity sensor kit	X	X	X		X	X	X		X	X	X		X	X
Power interface	X	X	X	X	X	X	X	X*	X*	X*	X	X		X*
Master slave for connection of up to 4 units	X	X	X	X	X	X	X	X*	X*	X*	X	X	X*	











NOTE
* = Power interface necessary only for FWD16AT/AF and FWD18AT/AF

4TW60229-2B(2)

4 Control systems

4 - 1 Control systems

FWD-AT/AF

	Cool/heat changeover			Options		Basic control functions		Control features		
										
2-pipe	X					X	X	X	X	
	X			X		X	X		X	
	X				X	X	X	X	X	
	X			X	X	X	X		X	
		X				X	X			
		X		X		X	X			
			X		X	X	X	X	X	X
4-pipe	X			X		X	X		X	
	X					X	X	X	X	
			X			X	X	X		X
			X	X		X	X		X	X

SYMBOLS



Manual cool/heat changeover.



Automatic cool/heat changeover based on water temperature.



Automatic cool/heat changeover based on air temperature.



Control of the 3-way/4pipe ON/OFF valve. The water valve shut-off once the desired temperature is reached.



The controller controls the electric heater as integration or replacement of the hot water heating system. When the operating mode selector switch is turned on "electric heater" and the electric heater is turned on, the fan runs continuously at medium speed. When the operating mode selector switch is turned to "electric heater" and the electric heater is turned on, the fan runs continuously at medium speed.



The fan speed can be set at one of the 3 speeds (low, medium or maximum) by turning the operation mode selector.



The fan speed is switched automatically based on the difference between the temperature set on the thermostat and the room temperature.



Optimised comfort cooling. When the fan coil has reached the desired setpoint, the fan will operate at medium speed and at regular intervals to ensure constant room temperature and lower sound.



The controller prevents the fan coil unit from operating in one mode, if the required water temperature is not achieved to operate in the selected mode.



The dead zone is a temperature interval close to the set temperature. When the air is warmer/cooler than the top/lower limit of the neutral zone, the cooling/heating mode is selected.

5 Capacity tables

5 - 1 Cooling Capacity Tables

2
5

FWD-AT/AF

Air temperature (°C DB - °C WB)		22-16															
Water temperature (Entering °C - leaving °C)		6-11				7-12				8-13				9-14			
Model	Air flow	Total cooling capacity	Sensible cooling capacity	Water flow	Water pressure drop	Total cooling capacity	Sensible cooling capacity	Water flow	Water pressure drop	Total cooling capacity	Sensible cooling capacity	Water flow	Water pressure drop	Total cooling capacity	Sensible cooling capacity	Water flow	Water pressure drop
	m ³ /h	W	W	l/h	kPa	W	W	l/h	kPa	W	W	l/h	kPa	W	W	l/h	kPa
FWD04AT/AF	400	1410	1250	241	3	1240	1240	213	2	1150	1150	197	2	1050	1050	180	2
	600	1850	1720	317	5	1590	1590	273	4	1440	1440	247	3	1310	1310	226	2
	800	2370	2200	406	7	2000	2000	343	5	1790	1790	307	4	1570	1570	269	3
FWD06AT/AF	800	2550	2290	437	5	2190	2190	376	4	2000	2000	343	3	1830	1830	314	3
	1000	3160	2780	542	7	2650	2650	455	5	2360	2360	405	4	2050	2050	352	3
	1250	3810	3320	653	10	3160	3160	543	7	2830	2830	486	6	2490	2490	427	5
FWD08AT/AF	1200	3470	3470	595	6	3120	3120	535	5	2750	2750	472	4	2500	2500	429	3
	1400	3930	3930	674	7	3550	3550	609	6	3150	3150	541	5	2720	2720	468	4
	1600	4360	4360	748	9	3950	3950	677	7	3520	3520	604	6	3070	3070	528	5
FWD10AT/AF	1200	3830	3830	657	4	3550	3550	610	3	3280	3280	563	3	3000	3000	515	2
	1400	4320	4320	742	5	3870	3870	663	4	3560	3560	612	3	3260	3260	560	3
	1600	4870	4870	835	6	4380	4380	751	5	3840	3840	660	4	3490	3490	600	3
FWD12AT/AF	1600	5600	5080	961	7	4660	4660	799	5	4130	4130	709	4	3630	3630	624	3
	1900	6550	5940	1123	9	5380	5380	923	6	4810	4810	825	5	4200	4200	721	4
	2000	6840	6210	1174	10	6050	6050	1038	8	5420	5420	931	7	4770	4770	819	5
FWD16AT/AF	2000	7760	6650	1331	9	5980	5980	1026	6	5350	5350	919	5	4780	4780	820	4
	2500	9350	8100	1604	13	7190	7190	1233	8	6470	6470	1111	7	5730	5730	984	5
	3000	10790	9460	1851	16	8280	8280	1421	10	7480	7480	1284	8	6660	6660	1144	7
FWD18AT/AF	2000	9140	7440	1569	13	7490	6750	1286	9	6060	6060	1041	6	5430	5430	932	5
	2500	10930	9070	1875	18	9040	8290	1551	13	7280	7280	1250	9	6540	6540	1124	7
	3000	12570	10630	2156	23	10430	9750	1792	17	8400	8400	1443	11	7560	7560	1298	9

4TW60222-1_A (Sheet 1/7)

FWD-AT/AF

Air temperature (°C DB - °C WB)		25-18															
Water temperature (Entering °C - leaving °C)		6-11				7-12				8-13				9-14			
Model	Air flow	Total cooling capacity	Sensible cooling capacity	Water flow	Water pressure drop	Total cooling capacity	Sensible cooling capacity	Water flow	Water pressure drop	Total cooling capacity	Sensible cooling capacity	Water flow	Water pressure drop	Total cooling capacity	Sensible cooling capacity	Water flow	Water pressure drop
	m ³ /h	W	W	l/h	kPa	W	W	l/h	kPa	W	W	l/h	kPa	W	W	l/h	kPa
FWD04AT/AF	400	2170	1620	371	6	1840	1490	317	5	1460	1350	252	3	1330	1330	227	3
	600	3010	2270	515	11	2590	2110	443	8	2110	1930	364	6	1800	1800	310	4
	800	3740	2860	641	16	3220	2660	554	12	2660	2450	457	9	2240	2240	385	6
FWD06AT/AF	800	4220	3070	724	12	3630	2840	623	9	2960	2580	508	6	2490	2490	428	5
	1000	5030	3660	968	17	4340	3390	745	13	3580	3100	616	9	2990	2990	511	7
	1250	5980	4330	1026	23	5180	4020	889	17	4310	3690	740	13	3540	3540	609	9
FWD08AT/AF	1200	6020	4740	1032	15	5180	4410	889	12	3870	3870	666	7	3550	3550	608	6
	1400	6770	5400	1161	19	5840	5040	1004	14	4370	4370	749	9	4010	4010	688	7
	1600	7470	6040	1282	22	6470	5650	1109	17	4830	4830	828	10	4440	4440	763	9
FWD10AT/AF	1200	6650	5130	1141	10	5640	4720	968	7	4260	4260	731	4	3870	3870	666	4
	1400	7570	5900	1300	12	6470	5460	1109	9	4870	4870	835	6	4450	4450	763	5
	1600	8440	6640	1447	15	7240	6170	1242	11	5450	5450	936	7	4990	4990	857	6
FWD12AT/AF	1600	8930	6680	1530	16	7730	6200	1328	12	6380	5680	1098	9	5250	5250	904	6
	1900	10220	7720	1753	20	8860	7180	1519	16	7370	6610	1267	11	6030	6030	1037	8
	2200	11420	8710	1958	24	9920	8120	1703	19	8280	7490	1422	14	6760	6760	1159	10
FWD16AT/AF	2000	11600	8520	1987	18	10180	7950	1746	15	8640	7340	1483	11	6670	6670	1145	7
	2500	13770	10270	2362	25	12120	9610	2077	20	10330	8910	1775	15	7970	7970	1368	9
	3000	15780	11930	2707	32	13890	11180	2383	25	11870	10410	2038	19	9150	9150	1573	12
FWD18AT/AF	2000	12920	9310	2218	25	11510	8720	1976	20	9990	8110	1714	15	8300	7450	1426	11
	2500	15380	11280	2635	33	13700	10600	2351	27	11900	9880	2045	21	9940	9120	1706	15
	3000	17650	13180	3028	42	15720	12400	2700	34	13670	11590	2347	27	11440	10740	1966	20

4TW60222-1_B (Sheet 2/7)

5 Capacity tables

5 - 1 Cooling Capacity Tables

FWD-AT/AF																	
Air temperature (°C DB - °C WB)		27-19															
Water temperature (Entering °C - leaving °C)		6-11				7-12				8-13				9-14			
Model	Air flow	Total cooling capacity	Sensible cooling capacity	Water flow	Water pressure drop	Total cooling capacity	Sensible cooling capacity	Water flow	Water pressure drop	Total cooling capacity	Sensible cooling capacity	Water flow	Water pressure drop	Total cooling capacity	Sensible cooling capacity	Water flow	Water pressure drop
	m³/h	W	W	l/h	kPa	W	W	l/h	kPa	W	W	l/h	kPa	W	W	l/h	kPa
FWD04AT/AF	400	2580	1870	443	8	2280	1750	392	7	1950	1620	335	5	1570	1480	270	3
	600	3560	2600	608	14	3150	2450	540	12	2720	2290	468	9	2250	2110	385	6
	800	4400	3270	756	21	3900	3080	674	17	3390	2890	583	13	2660	2660	457	9
FWD06AT/AF	800	4990	3520	857	16	4430	3300	760	13	3830	3070	659	10	3160	2820	544	7
	1000	5920	4180	1015	22	5270	3930	904	18	4570	3660	785	14	3800	3380	652	10
FWD08AT/AF	1200	7100	5420	1217	20	6310	5110	1084	17	5460	4790	936	13	4230	4230	727	8
	1400	7970	6160	1368	25	7090	5820	1217	20	6150	5470	1055	16	4760	4760	817	10
	1600	8790	6890	1508	30	7800	6520	1339	24	6800	6130	1166	19	5260	5260	904	12
FWD10AT/AF	1200	7910	5890	1357	13	6990	5530	1199	11	5990	5140	1026	8	4690	4690	806	5
	1400	8960	6760	1537	17	7950	6360	1364	13	6840	5930	1174	10	5340	5340	918	7
	1600	9970	7600	1710	20	8820	7160	1514	16	7640	6700	1310	12	5950	5950	1022	8
FWD12AT/AF	1600	10490	7630	1800	21	9350	7170	1606	17	8130	6700	1397	13	6780	6190	1166	10
	1900	11970	8800	2056	26	10690	8290	1832	22	9310	7760	1598	17	7800	7200	1339	12
	2200	13370	9920	2293	32	11900	9360	2056	26	10410	8780	1786	20	8740	8170	1501	15
FWD16AT/AF	2000	13450	9670	2308	24	12100	9130	2077	20	10660	8560	1829	16	9100	7970	1562	12
	2500	15950	11640	2736	32	14360	11010	2466	27	12670	10360	2178	21	10850	9670	1865	16
	3000	18260	13510	3136	41	16400	12800	2833	34	14520	12060	2491	27	12450	11290	2138	21
FWD18AT/AF	2000	14790	10490	2538	31	13430	9930	2304	26	11990	9350	2059	21	10440	8740	1793	17
	2500	17610	12710	3020	42	15990	12050	2743	35	14270	11370	2448	29	12430	10660	2135	23
	3000	20150	14820	3456	53	18300	14100	3140	45	16370	13320	2812	37	14270	12520	2452	29

4TW60222-1_C (Sheet 3/7)

5 Capacity tables

5 - 2 Cooling Capacity Tables Glycol 40 %

FWD-AT/AF

Cooling mode

Glycol percentage in weight	Freezing temperature (°C)	Capacity correction factor	Pressure drop correction factor
0	0	1	1.00
10	-4	0.93	1.09
20	-10	0.84	1.18
30	-16	0.76	1.27
40	-24	0.76	1.36

Heating mode

Glycol percentage in weight	Freezing temperature (°C)	Capacity correction factor	Pressure drop correction factor
0	0	1	1.00
10	-4	0.98	1.08
20	-10	0.97	1.11
30	-16	0.94	1.22
40	-24	0.91	1.33

NOTES

Correction factors are based on an average value (at rated water flow rate). This can cause deviation depending on conditions used.
The Fan Coil Selection software will provide an accurate result at all conditions.

4TW60228-1B

5 Capacity tables

5 - 3 Heating Capacity Tables

FWD-AF

Air temperature (°C)		20												
Water temperature (Entering °C - leaving °C)		50-45				60-50			70-60			90-70		
Model	Air flow	Heating capacity	Water flow	Water pressure drop	Heating capacity	Water flow	Water pressure drop	Heating capacity	Water flow	Water pressure drop	Heating capacity	Water flow	Water pressure drop	
	m ³ /h	W	l/h	kPa	W	l/h	kPa	W	l/h	kPa	W	l/h	kPa	
FWD04AF	400	1950	338	7	2370	209	3	3190	281	5	4150	184	2	
	600	2390	418	11	2930	256	4	3920	346	7	5090	223	3	
	800	2740	479	13	3360	292	6	4490	396	9	5820	256	4	
FWD06AF	800	3280	569	16	4060	356	7	5370	472	10	7030	310	5	
	1000	3650	634	19	4510	392	8	5970	526	13	7800	346	6	
	1250	4040	704	22	4990	436	9	6620	581	15	8620	381	7	
FWD08AF	1200	4900	853	15	6040	526	6	8030	706	10	10460	461	5	
	1400	5280	918	17	6490	569	7	8650	760	12	11250	497	5	
	1600	5620	979	19	6900	605	8	9210	806	13	11960	529	6	
FWD10AF	1200	4900	853	15	6040	526	6	8030	706	10	10460	461	5	
	1400	5280	918	17	6490	569	7	8650	760	12	11250	497	5	
	1600	5620	979	19	6900	605	8	9210	806	13	11960	529	6	
FWD12AF	1600	7930	1382	13	9880	864	5	13020	1141	9	17110	756	4	
	1900	8840	1541	15	10990	961	7	14500	1271	10	19020	839	5	
	2200	9670	1685	18	12010	1051	8	15860	1393	12	20790	918	6	
FWD16AF	2000	10020	1746	15	12540	1094	6	16450	1444	10	21690	958	5	
	2500	11530	2009	19	14400	1260	8	18920	1660	13	24900	1098	6	
	3000	12900	2246	23	16080	1404	10	21150	1854	16	27790	1228	7	
FWD18AF	2000	10020	1746	15	12540	1094	6	16450	1444	10	21690	958	5	
	2500	11530	2009	19	14400	1260	8	18920	1660	13	24900	1098	6	
	3000	12900	2246	23	16080	1404	10	21150	1854	16	27790	1228	7	

4TW60222-1_C (Sheet 6/7)

FWD-AF

Air temperature (°C)		22												
Water temperature (Entering °C - leaving °C)		50-45				60-50			70-60			90-70		
Model	Air flow	Heating capacity	Water flow	Water pressure drop	Heating capacity	Water flow	Water pressure drop	Heating capacity	Water flow	Water pressure drop	Heating capacity	Water flow	Water pressure drop	
	m ³ /h	W	l/h	kPa	W	l/h	kPa	W	l/h	kPa	W	l/h	kPa	
FWD04AF	400	1790	313	6	2210	194	3	3030	266	4	3990	176	2	
	600	2200	385	9	2730	238	4	3730	328	6	4900	216	3	
	800	2520	439	12	3130	274	5	4270	374	8	5590	248	4	
FWD06AF	800	3020	526	13	3800	331	6	5110	446	10	6760	299	4	
	1000	3360	587	16	4220	367	7	5680	500	11	7510	331	5	
	1250	3720	648	19	4670	408	8	6290	552	14	8300	366	6	
FWD08AF	1200	4510	785	13	5640	493	6	7630	670	9	10060	443	4	
	1400	4860	846	15	6070	529	6	8220	720	11	10820	479	5	
	1600	5170	900	17	6450	565	7	8750	767	12	11500	508	6	
FWD10AF	1200	4510	785	13	5640	493	6	7630	670	9	10060	443	4	
	1400	4860	846	15	6070	529	6	8220	720	11	10820	479	5	
	1600	5170	900	17	6450	565	7	8750	767	12	11500	508	6	
FWD12AF	1600	7310	1274	11	9250	810	5	12380	1087	8	16460	727	4	
	1900	8140	1418	13	6970	608	8	13790	1210	9	18310	806	4	
	2200	8910	1552	16	11250	983	7	15090	1325	11	20010	882	5	
FWD16AF	2000	9240	1609	13	11760	1026	6	15650	1372	9	20880	922	4	
	2500	10630	1854	17	13490	1177	7	18000	1580	12	23970	1058	6	
	3000	11890	2070	20	15070	1318	9	20130	1764	14	26760	1181	7	
FWD18AF	2000	9240	1609	13	11760	1026	6	15650	1372	9	20880	922	4	
	2500	10630	1854	17	13490	1177	7	18000	1580	12	23970	1058	6	
	3000	11890	2070	20	15070	1318	9	20130	1764	14	26760	1181	7	

4TW60222-1_D (Sheet 7/7)

5 Capacity tables

5 - 4 Capacity Correction Factor

2
5

FWD-AT/AF

	ESP (Pa)	0		20		40		60		80		100		120		140		160		180		200		220		240	
	Fan speed	F1	F2	F1	F2	F1	F2	F1	F2	F1	F2	F1	F2	F1	F2	F1	F2	F1	F2	F1	F2	F1	F2	F1	F2	F1	F2
FWD04AT/AF	Max.	1.18	1.13	1.13	1.09	1.08	1.06	1.02	1.02	0.96	0.97	0.89	0.92	0.80	0.85	0.70	0.77	0.53	0.62	-	-	-	-	-	-	-	-
	Med.	1.34	1.24	1.28	1.20	1.21	1.15	1.13	1.10	1.04	1.03	0.95	0.96	0.82	0.86	0.65	0.71	-	-	-	-	-	-	-	-	-	-
	Min.	1.44	1.34	1.37	1.29	1.29	1.23	1.20	1.16	1.10	1.08	0.97	0.98	0.79	0.82	-	-	-	-	-	-	-	-	-	-	-	-
FWD06AT/AF	Max.	1.26	1.19	1.18	1.13	1.09	1.07	0.99	0.99	0.88	0.91	0.75	0.81	0.60	0.68	0.40	0.48	-	-	-	-	-	-	-	-	-	-
	Med.	1.37	1.26	1.28	1.20	1.19	1.13	1.08	1.06	0.97	0.97	0.87	0.87	0.67	0.73	0.44	0.50	-	-	-	-	-	-	-	-	-	-
	Min.	1.47	1.34	1.38	1.28	1.28	1.21	1.17	1.13	1.04	1.03	0.90	0.92	0.72	0.77	0.45	0.50	-	-	-	-	-	-	-	-	-	-
FWD08AT/AF	Max.	1.28	1.20	1.21	1.15	1.13	1.09	1.04	1.03	0.94	0.96	0.83	0.88	0.71	0.77	0.55	0.63	0.30	0.36	-	-	-	-	-	-	-	-
	Med.	1.18	1.13	1.11	1.08	1.03	1.02	0.94	0.96	0.85	0.88	0.74	0.79	0.61	0.68	0.42	0.49	-	-	-	-	-	-	-	-	-	-
	Min.	1.15	1.11	1.08	1.06	1.00	1.00	0.91	0.93	0.82	0.85	0.70	0.75	0.56	0.62	0.35	0.41	-	-	-	-	-	-	-	-	-	-
FWD10AT/AF	Max.	1.26	1.20	1.18	1.14	1.10	1.08	1.02	1.02	0.92	0.94	0.82	0.85	0.70	0.74	0.54	0.60	0.31	0.38	-	-	-	-	-	-	-	-
	Med.	1.17	1.14	1.10	1.08	1.02	1.02	0.94	0.95	0.84	0.87	0.73	0.77	0.60	0.64	0.41	0.46	-	-	-	-	-	-	-	-	-	-
	Min.	1.14	1.12	1.07	1.06	0.99	0.99	0.91	0.92	0.81	0.83	0.70	0.72	0.56	0.57	0.35	0.43	-	-	-	-	-	-	-	-	-	-
FWD12AT/AF	Max.	1.35	1.24	1.29	1.21	1.22	1.16	1.15	1.11	1.07	1.06	0.99	0.99	0.89	0.92	0.77	0.82	0.61	0.68	-	-	-	-	-	-	-	-
	Med.	1.16	1.12	1.10	1.08	1.03	1.03	0.96	0.97	0.88	0.91	0.79	0.83	0.69	0.74	0.56	0.62	0.35	0.40	-	-	-	-	-	-	-	-
	Min.	1.02	1.02	0.96	0.97	0.89	0.91	0.82	0.85	0.74	0.78	0.65	0.70	0.54	0.59	0.39	0.43	-	-	-	-	-	-	-	-	-	-
FWD16AT/AF	Max.	1.13	1.10	1.12	1.09	1.10	1.07	1.08	1.06	1.06	1.05	1.04	1.04	1.03	1.02	1.01	1.01	0.98	0.99	0.96	0.98	0.94	0.96	0.92	0.94	0.89	0.92
	Med.	1.11	1.08	1.09	1.07	1.07	1.05	1.04	1.03	1.02	1.02	1.00	1.00	0.97	0.98	0.95	0.96	0.92	0.94	0.89	0.92	0.86	0.89	0.83	0.86	0.79	0.84
	Min.	1.09	1.07	1.06	1.05	1.03	1.03	1.01	1.01	0.98	0.99	0.95	0.96	0.92	0.94	0.89	0.91	0.86	0.88	0.82	0.85	0.78	0.82	0.74	0.78	0.69	0.74
FWD18AT/AF	Max.	1.12	1.09	1.11	1.08	1.09	1.06	1.07	1.05	1.05	1.04	1.03	1.03	1.01	1.01	0.99	1.00	0.97	0.98	0.95	0.97	0.93	0.95	0.91	0.93	0.88	0.91
	Med.	1.10	1.07	1.07	1.06	1.05	1.04	1.03	1.02	1.01	1.01	0.98	0.99	0.96	0.97	0.93	0.95	0.90	0.92	0.87	0.90	0.84	0.88	0.81	0.85	0.78	0.82
	Min.	1.08	1.06	1.05	1.04	1.03	1.02	1.00	1.00	0.97	0.98	0.94	0.95	0.91	0.93	0.88	0.90	0.84	0.87	0.81	0.84	0.77	0.81	0.72	0.77	0.67	0.72

NOTES

Conditions

Cooling

Heating 2-pipe

Heating 4-pipe

Air: 27°C DB - 19°C WB - Water: entering 7°C - leaving 12°C

Air: 20°C Water: entering 50°C water flow as for cooling

Air: 20°C Water: entering 70°C - leaving 60°C

F1 = correction factor for air flow

F2 = correction factor for capacities

The correction factor is applicable also for 4-pipe and heating mode because the differences are negligible.

4TW60228-1A

6 Power Consumption

FWD-AT/AF

FWD04AT/AF	Max.		Med.		Min.	
	Power input	Current	Power input	Current	Power input	Current
(Pa)	(W)	(A)	(W)	(A)	(W)	(A)
0	234	0.954	173	0.740	130	0.568
10	228	0.946	169	0.740	122	0.550
20	221	0.940	165	0.731	120	0.530
30	211	0.912	161	0.720	117	0.525
40	203	0.890	157	0.702	114	0.514
50	196	0.857	148	0.655	112	0.496
60	182	0.792	144	0.633	109	0.485
70	173	0.754	140	0.616	107	0.473
80	166	0.710	132	0.573	104	0.456
90	158	0.671	125	0.545	100	0.444
100	153	0.639	120	0.520	95	0.419
120	141	0.594	112	0.477	85	0.375
140	130	0.542	97	0.428	77	0.327
160	115	0.471	-	-	-	-

SYMBOL

ESP: External static pressure

4TW60221-2_A

FWD-AT/AF

FWD06AT/AF	Max.		Med.		Min.	
	Power input	Current	Power input	Current	Power input	Current
(Pa)	(W)	(A)	(W)	(A)	(W)	(A)
0	349	1.575	294	1.389	247	1.183
10	329	1.530	275	1.322	238	1.150
20	317	1.490	263	1.287	230	1.120
30	303	1.470	256	1.246	225	1.092
40	295	1.430	246	1.194	218	1.065
50	286	1.380	237	1.159	210	1.036
60	274	1.340	228	1.115	204	1.001
70	264	1.306	218	1.078	199	0.974
80	256	1.265	212	1.038	187	0.933
90	246	1.220	200	0.986	180	0.885
100	235	1.170	191	0.951	170	0.849
110	224	1.130	183	0.910	159	0.791
120	212	1.090	167	0.841	145	0.730
130	192	1.010	154.0	0.790	136	0.691
140	178	0.967	140.0	0.725	120	0.623
150	161	0.905	126.0	0.688	114	0.598
160	152	0.880	-	-	-	-

SYMBOL

ESP: External static pressure

4TW60221-2_B

6 Power Consumption

2
6

FWD-AT/AF

FWD08AT/AF	Max.		Med.		Min.	
	Power input	Current	Power input	Current	Power input	Current
(Pa)	(W)	(A)	(W)	(A)	(W)	(A)
0	443	1.971	336	1.515	261	1.204
10	420	1.915	317	1.475	247	1.186
20	404	1.850	301	1.418	238	1.144
30	382	1.808	290	1.366	231	1.106
40	367	1.715	279	1.330	221	1.045
52	353	1.670	262	1.246	212	1.008
60	335	1.582	251	1.189	203	0.972
70	315	1.508	248	1.163	195	0.935
80	302	1.430	233	1.109	186	0.885
90	280	1.350	221	1.045	176	0.839
100	267	1.292	210	0.994	168	0.804
110	254	1.224	198	0.936	155	0.741
120	238	1.166	185	0.889	146	0.705
130	225	1.106	172	0.826	135	0.648
140	203	1.028	155	0.746	126	0.605
150	193	0.970	142	0.682	118	0.576
160	174	0.897	-	-	-	-

SYMBOL

ESP: External static pressure

4TW60221-2_C

FWD-AT/AF

FWD10AT/AF	Max.		Med.		Min.	
	Power input	Current	Power input	Current	Power input	Current
(Pa)	(W)	(A)	(W)	(A)	(W)	(A)
0	443	1.971	336	1.515	261	1.204
10	420	1.915	317	1.475	247	1.186
20	404	1.850	301	1.418	238	1.144
30	382	1.808	290	1.366	231	1.106
40	367	1.715	279	1.330	221	1.045
52	353	1.670	262	1.246	212	1.008
60	335	1.582	251	1.189	203	0.972
70	315	1.508	248	1.163	195	0.935
80	302	1.430	233	1.109	186	0.885
90	280	1.350	221	1.045	176	0.839
100	267	1.292	210	0.994	168	0.804
110	254	1.224	198	0.936	155	0.741
120	238	1.166	185	0.889	146	0.705
130	225	1.106	172	0.826	135	0.648
140	203	1.028	155	0.746	126	0.605
150	193	0.970	142	0.682	118	0.576
160	174	0.897	-	-	-	-

SYMBOL

ESP: External static pressure

4TW60221-2_D

6 Power Consumption

FWD-AT/AF

FWD12AT/AF	Max.		Med.		Min.	
	Power input	Current	Power input	Current	Power input	Current
(Pa)	(W)	(A)	(W)	(A)	(W)	(A)
0	714	3.210	473	2.080	328	1.500
10	683	3.100	452	2.070	309	1.485
20	663	3.070	440	2.060	303	1.460
30	646	3.020	430	2.040	299	1.438
40	630	2.990	420	1.970	290	1.403
50	620	2.950	415	1.915	287	1.382
60	604	2.895	402	1.900	278	1.338
70	580	2.800	390	1.860	272	1.306
80	570	2.730	380	1.790	267	1.280
90	550	2.650	370	1.730	257	1.236
100	530	2.600	350	1.650	252	1.213
110	520	2.540	340	1.600	249	1.190
120	490	2.450	330	1.540	244	1.173
130	480	2.390	320	1.480	239	1.139
140	450	2.300	310	1.440	235	1.118
150	440	2.225	300	1.380	230	1.100
160	430	2.210	-	-	-	-

SYMBOL

ESP: External static pressure

4TW60221-2_E

FWD-AT/AF

FWD16AT/AF	Max.		Med.		Min.	
	Power input	Current	Power input	Current	Power input	Current
(Pa)	(W)	(A)	(W)	(A)	(W)	(A)
0	1197	5.370	966	4.380	704	3.260
10	1159	5.300	921	4.200	680	3.250
20	1130	5.250	897	4.090	672	3.240
30	1112	5.200	879	4.046	660	3.200
40	1092	5.100	864	3.986	650	3.150
50	1086	5.090	848	3.930	640	3.080
60	1068	5.060	842	3.910	638	3.010
70	1060	5.020	830	3.883	629	2.990
80	1051	5.000	820	3.823	624	2.963
90	1050	4.960	810	3.774	620	2.958
100	1034	4.930	800	3.693	610	2.930
110	1026	4.900	790	3.620	600	2.870
120	1017	4.880	760	3.540	590	2.830
130	1006	4.850	743	3.480	580	2.790
140	997	4.820	730	3.420	570	2.740
150	985	4.790	717	3.400	556	2.690
160	973	4.760	710	3.350	540	2.600
170	963	4.690	703	3.300	532	2.566
180	944	4.620	680	3.200	520	2.470
190	926	4.550	661	3.133	-	-
200	912	4.493	655	3.120	-	-
210	894	4.405	-	-	-	-
220	877	4.313	-	-	-	-
230	860	4.215	-	-	-	-
240	848	4.150	-	-	-	-
250	841	4.117	-	-	-	-

SYMBOL

ESP: External static pressure

4TW60221-2_F

6 Power Consumption

2
6

FWD-AT/AF

FWD18AT/AF	Max.		Med.		Min.	
	Power input	Current	Power input	Current	Power input	Current
(Pa)	(W)	(A)	(W)	(A)	(W)	(A)
0	1197	5.370	966	4.380	704	3.260
10	1159	5.300	921	4.200	680	3.250
20	1130	5.250	897	4.090	672	3.240
30	1112	5.200	879	4.046	660	3.200
40	1092	5.100	864	3.986	650	3.150
50	1086	5.090	848	3.930	640	3.080
60	1068	5.060	842	3.910	638	3.010
70	1060	5.020	830	3.883	629	2.990
80	1051	5.000	820	3.823	624	2.963
90	1050	4.960	810	3.774	620	2.958
100	1034	4.930	800	3.693	610	2.930
110	1026	4.900	790	3.620	600	2.870
120	1017	4.880	760	3.540	590	2.830
130	1006	4.850	743	3.480	580	2.790
140	997	4.820	730	3.420	570	2.740
150	985	4.790	717	3.400	556	2.690
160	973	4.760	710	3.350	540	2.600
170	963	4.690	703	3.300	532	2.566
180	944	4.620	680	3.200	520	2.470
190	926	4.550	661	3.133	-	-
200	912	4.493	655	3.120	-	-
210	894	4.405	-	-	-	-
220	877	4.313	-	-	-	-
230	860	4.215	-	-	-	-
240	848	4.150	-	-	-	-
250	841	4.117	-	-	-	-

SYMBOL

ESP: External static pressure

4TW60221-2_G

7 Dimensional drawings

7 - 1 Dimensional drawings

FWD04-06-08-10AT/AF

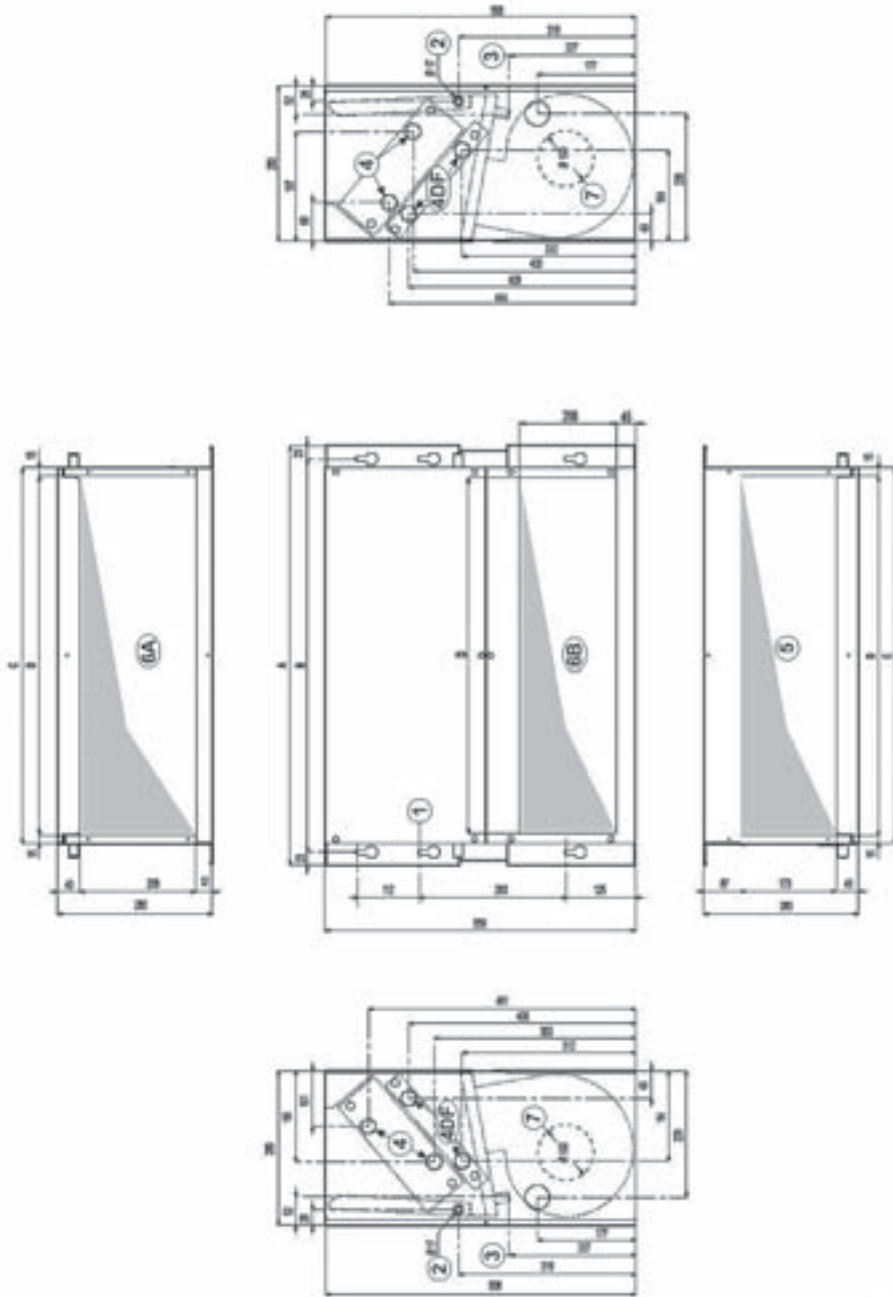

4TW60224-1A_A

NOTES

- 1 6 fast-coupling slots
- 2 Condensate drainage for horizontal installation
- 3 Condensate drainage for vertical installation
- 4 Hydraulic connections
4 = standard heat exchanger
4 DF = supplementary heat exchanger
- 5 Air delivery
- 6 Air intake
6A = supply terms
6B = changeable during installation
- 7 Round pre-sheared element (J 100 mm) for fresh air intake

FWD04AT/AF	FWD06AT/AF	FWD08AT/AF	FWD10AT/AF	FWD12AT/AF	FWD16AT/AF	FWD18AT/AF
3/4"	3/4"	3/4"	3/4"	1"	1"	1"

	A	B	C	D
FWD04AT/AF	754	707	676	646
FWD06AT/AF	964	917	886	856
FWD08+10AT/AF	1174	1127	1096	1066

7 Dimensional drawings

7 - 1 Dimensional drawings

FWD12-16-18AT/AF

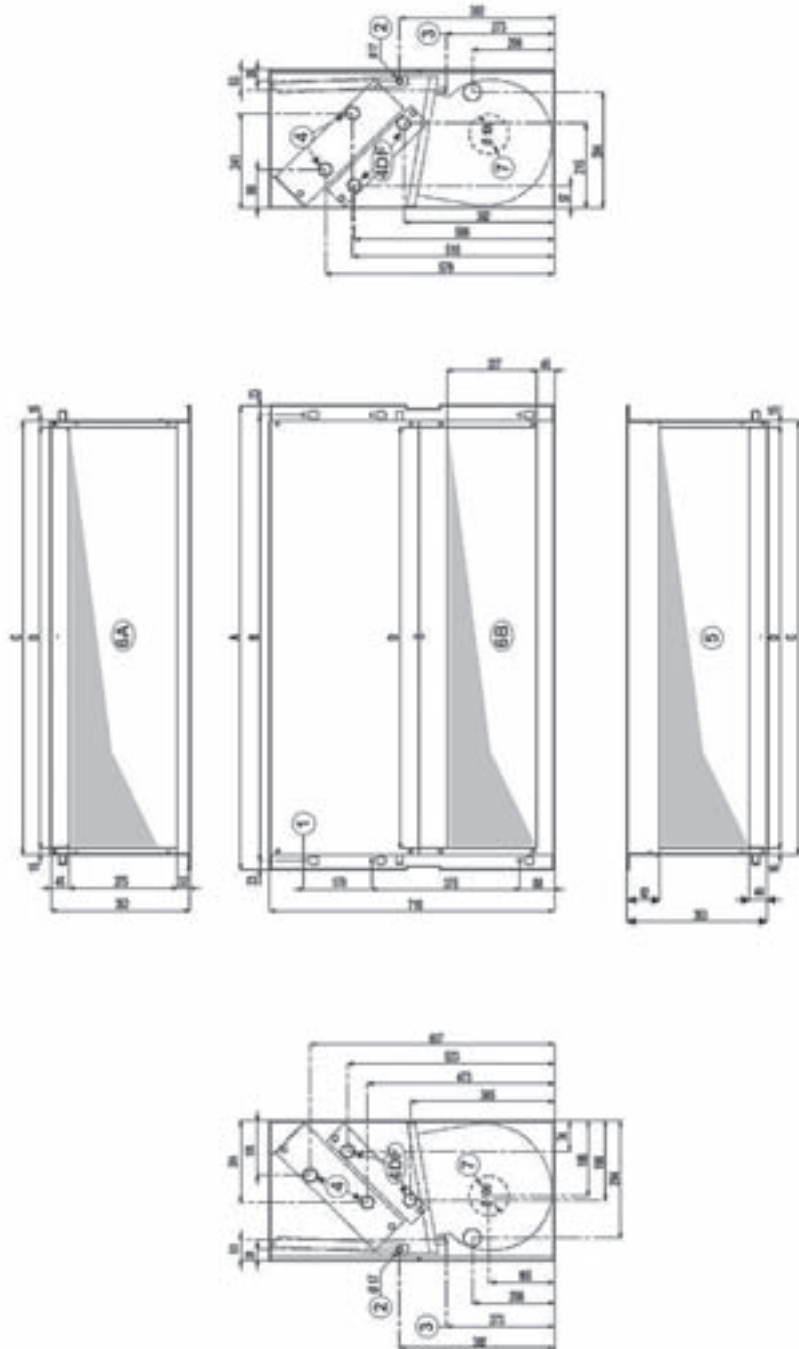

4TW60224-1A_B

NOTES

- 1 6 fast-coupling slots
- 2 Condensate drainage for horizontal installation
- 3 Condensate drainage for vertical installation
- 4 Hydraulic connections
4 = standard heat exchanger
4 DF = supplementary heat exchanger
- 5 Air delivery
- 6 Air intake
6A = supply terms
6B = changeable during installation
- 7 Round pre-sheared element (J 100 mm) for fresh air intake

FWD04AT/AF	FWD06AT/AF	FWD08AT/AF	FWD10AT/AF	FWD12AT/AF	FWD16AT/AF	FWD18AT/AF
3/4"	3/4"	3/4"	3/4"	1"	1"	1"

	A	B	C	D
FWD12AT/AF	1174	1127	1096	1066
FWD16+18AT/AF	1384	1337	1306	1276

8 Wiring diagrams

8 - 1 Wiring diagrams - Single Phase

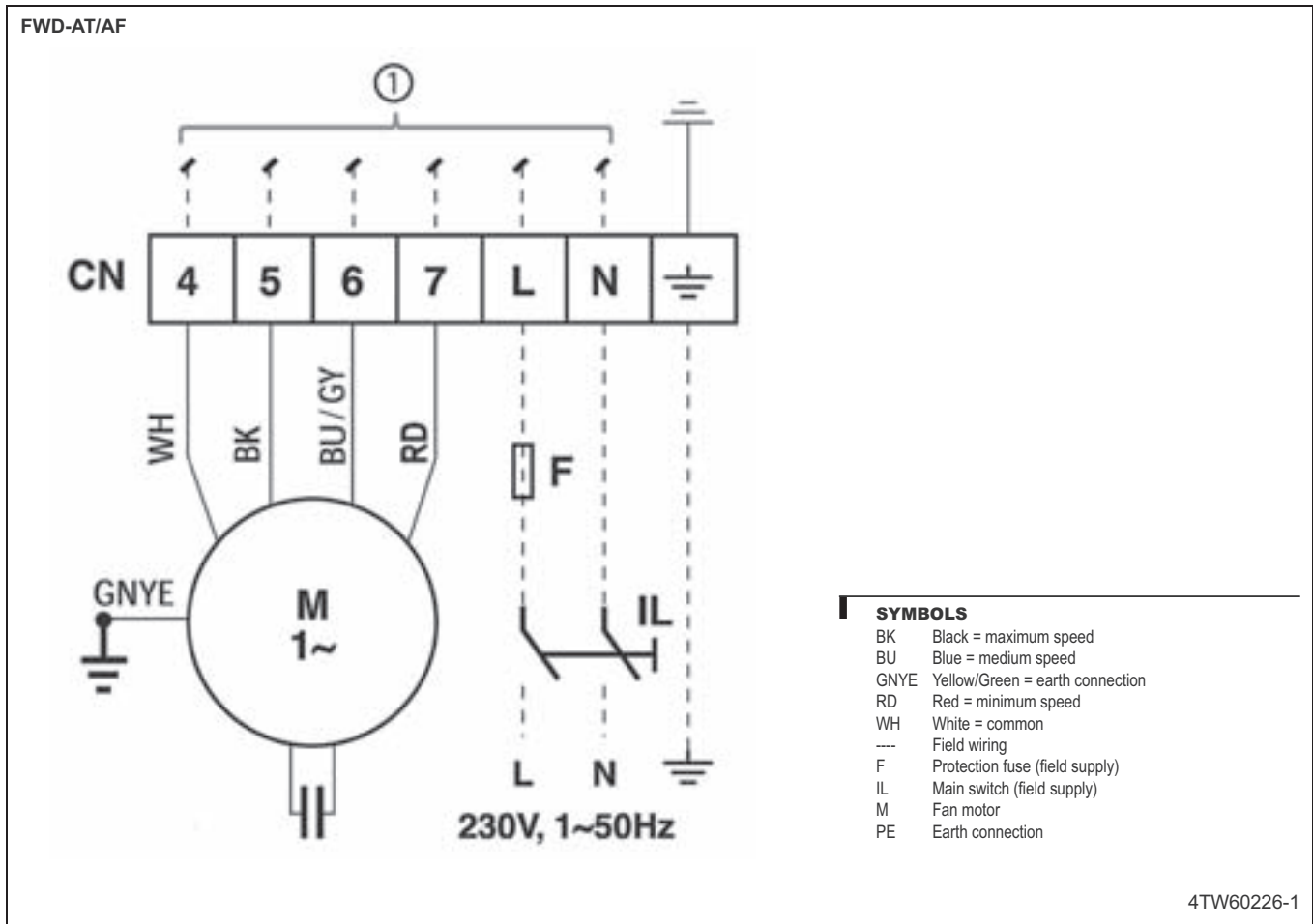

9 Sound data

9 - 1 Sound Level Data

2
9

FWD04AT/AF

FWD04AT/AF		125 Hz	250 Hz	500 Hz	1000 Hz	2000 Hz	4000 Hz	8000 Hz	Global Lw
Max.	L _w tot dB(A)	43.6	47.0	60.0	62.0	60.7	54.8	46.2	66
		125 Hz	250 Hz	500 Hz	1000 Hz	2000 Hz	4000 Hz	8000 Hz	
	Outlet	40.4	43.3	55.9	58.4	57.0	51.4	42.9	62.5
	Structure	29.3	38.5	53.6	53.0	52.1	43.8	34.3	58.0
	Inlet 57.8	40.4	43.3	55.9	58.4	57.0	51.4	42.9	62.5
Med.	L _w tot dB(A)	40.7	53.8	53.8	57.0	53.6	50.6	43.3	61
		125 Hz	250 Hz	500 Hz	1000 Hz	2000 Hz	4000 Hz	8000 Hz	
	Outlet	37.5	50.2	49.7	53.4	49.9	47.2	40.0	57.7
	Structure	26.4	45.3	47.4	47.9	45.0	39.6	31.5	52.9
	Inlet	37.5	50.2	49.7	53.4	49.9	47.2	40.0	57.7
Min.	L _w tot dB(A)	33.8	47.7	47.0	49.8	47.0	41.9	33.5	54
		125 Hz	250 Hz	500 Hz	1000 Hz	2000 Hz	4000 Hz	8000 Hz	
	Outlet	30.6	44.1	42.9	46.2	43.3	38.6	30.2	50.7
	Structure	19.5	39.2	40.6	40.8	38.4	30.9	21.6	46.0
	Inlet	30.6	44.1	42.9	46.2	43.3	38.6	30.2	50.7

NOTE

1. Sound power levels measured at ESP = 0 Pa.

4TW60227-1_A

FWD06AT/AF

FWD06AT/AF		125 Hz	250 Hz	500 Hz	1000 Hz	2000 Hz	4000 Hz	8000 Hz	Global Lw
Max.	L _w tot dB(A)	45.0	56.9	60.8	64.7	63.5	57.7	49.7	69
		125 Hz	250 Hz	500 Hz	1000 Hz	2000 Hz	4000 Hz	8000 Hz	
	Outlet	41.8	53.2	56.7	61.2	59.9	54.4	46.4	65.2
	Structure	30.7	48.3	54.4	55.7	55.0	46.7	37.8	60.3
	Inlet 57.8	41.8	53.2	56.7	61.2	59.9	54.4	46.4	65.2
Med.	L _w tot dB(A)	41.5	52.6	56.9	59.0	54.7	50.9	40.5	63
		125 Hz	250 Hz	500 Hz	1000 Hz	2000 Hz	4000 Hz	8000 Hz	
	Outlet	38.3	49.0	52.7	55.4	51.1	47.6	37.2	59.1
	Structure	27.2	44.1	50.4	50.0	46.2	39.9	28.7	54.6
	Inlet	38.3	49.0	52.7	55.4	51.1	47.6	37.2	59.1
Min.	L _w tot dB(A)	37.0	48.8	53.0	54.4	50.0	48.6	33.5	59
		125 Hz	250 Hz	500 Hz	1000 Hz	2000 Hz	4000 Hz	8000 Hz	
	Outlet	33.9	45.1	48.8	50.8	46.3	45.3	30.2	54.9
	Structure	22.8	40.3	46.5	45.3	41.4	37.6	21.6	50.4
	Inlet	33.9	45.1	48.8	50.8	46.3	45.3	30.2	54.9

NOTE

1. Sound power levels measured at ESP = 0 Pa.

4TW60227-1_B

9 Sound data

9 - 1 Sound Level Data

FWD08AT/AF

FWD08AT/AF		125 Hz	250 Hz	500 Hz	1000 Hz	2000 Hz	4000 Hz	8000 Hz	Global Lw
Max.	L _w tot dB(A)	50.7	62.1	64.8	68.1	66.5	62.5	56.2	72
		125 Hz	250 Hz	500 Hz	1000 Hz	2000 Hz	4000 Hz	8000 Hz	
	Outlet	47.5	58.4	60.7	64.5	62.8	59.1	52.9	68.9
	Structure	36.4	53.6	58.4	59.1	57.9	51.5	44.3	64.0
	Inlet 57.8	47.5	58.4	60.7	64.5	62.8	59.1	52.9	68.9
Med.	L _w tot dB(A)	45.0	57.5	60.1	62.5	58.9	56.4	49.2	67
		125 Hz	250 Hz	500 Hz	1000 Hz	2000 Hz	4000 Hz	8000 Hz	
	Outlet	41.8	53.8	56.0	58.9	55.3	53.0	45.9	63.0
	Structure	30.7	49.0	53.7	53.5	50.4	45.4	37.3	58.4
	Inlet	41.8	53.8	56.0	58.9	55.3	53.0	45.9	63.0
Min.	L _w tot dB(A)	40.5	53.4	55.9	57.5	54.3	50.3	42.4	62
		125 Hz	250 Hz	500 Hz	1000 Hz	2000 Hz	4000 Hz	8000 Hz	
	Outlet	37.4	49.7	51.8	53.9	50.6	46.9	39.1	58.2
	Structure	26.3	44.9	49.5	48.4	45.7	39.3	30.5	53.7
	Inlet	37.4	49.7	51.8	53.9	50.6	46.9	39.1	58.2

NOTE

1. Sound power levels measured at ESP = 0 Pa.

4TW60227-1_C

FWD10AT/AF

FWD10AT/AF		125 Hz	250 Hz	500 Hz	1000 Hz	2000 Hz	4000 Hz	8000 Hz	Global Lw
Max.	L _w tot dB(A)	50.7	62.1	64.8	68.1	66.5	62.5	56.2	72
		125 Hz	250 Hz	500 Hz	1000 Hz	2000 Hz	4000 Hz	8000 Hz	
	Outlet	47.5	58.4	60.7	64.5	62.8	59.1	52.9	68.9
	Structure	36.4	53.6	58.4	59.1	57.9	51.5	44.3	64.0
	Inlet 57.8	47.5	58.4	60.7	64.5	62.8	59.1	52.9	68.9
Med.	L _w tot dB(A)	45.0	57.5	60.1	62.5	58.9	56.4	49.2	67
		125 Hz	250 Hz	500 Hz	1000 Hz	2000 Hz	4000 Hz	8000 Hz	
	Outlet	41.8	53.8	56.0	58.9	55.3	53.0	45.9	63.0
	Structure	30.7	49.0	53.7	53.5	50.4	45.4	37.3	58.4
	Inlet	41.8	53.8	56.0	58.9	55.3	53.0	45.9	63.0
Min.	L _w tot dB(A)	40.5	53.4	55.9	57.5	54.3	50.3	42.4	62
		125 Hz	250 Hz	500 Hz	1000 Hz	2000 Hz	4000 Hz	8000 Hz	
	Outlet	37.4	49.7	51.8	53.9	50.6	46.9	39.1	58.2
	Structure	26.3	44.9	49.5	48.4	45.7	39.3	30.5	53.7
	Inlet	37.4	49.7	51.8	53.9	50.6	46.9	39.1	58.2

NOTE

1. Sound power levels measured at ESP = 0 Pa.

4TW60227-1_D

9 Sound data

9 - 1 Sound Level Data

2
9

FWD12AT/AF

FWD12AT/AF		125 Hz	250 Hz	500 Hz	1000 Hz	2000 Hz	4000 Hz	8000 Hz	Global Lw
Max.	L _w tot dB(A)	52.0	62.5	65.2	70.0	69.2	64.5	58.2	74
		125 Hz	250 Hz	500 Hz	1000 Hz	2000 Hz	4000 Hz	8000 Hz	
	Outlet	48.8	58.8	61.1	66.4	65.5	61.1	54.9	70.7
	Structure	37.7	54.0	58.8	61.0	60.6	53.5	46.3	65.7
	Inlet 57.8	48.8	58.8	61.1	66.4	65.5	61.1	54.9	70.7
Med.	L _w tot dB(A)	46.2	57.7	59.9	62.8	60.5	57.1	50.0	67
		125 Hz	250 Hz	500 Hz	1000 Hz	2000 Hz	4000 Hz	8000 Hz	
	Outlet	43.1	54.0	55.8	59.2	56.9	53.8	46.8	63.5
	Structure	32.0	49.2	53.5	53.8	52.0	46.1	38.2	58.8
	Inlet	43.1	54.0	55.8	59.2	56.9	53.8	46.8	63.5
Min.	L _w tot dB(A)	39.3	50.6	54.2	55.9	53.1	47.8	41.5	60
		125 Hz	250 Hz	500 Hz	1000 Hz	2000 Hz	4000 Hz	8000 Hz	
	Outlet	36.1	46.9	50.1	52.4	49.5	44.4	38.2	56.5
	Structure	25.0	42.1	47.8	46.9	44.6	36.8	29.6	52.0
	Inlet	36.1	46.9	50.1	52.4	49.5	44.4	38.2	56.5

NOTE

1. Sound power levels measured at ESP = 0 Pa.

4TW60227-1_D

FWD16AT/AF

FWD16AT/AF		125 Hz	250 Hz	500 Hz	1000 Hz	2000 Hz	4000 Hz	8000 Hz	Global Lw
Max.	L _w tot dB(A)	61.0	70.5	70.0	72.5	71.1	69.6	63.8	78
		125 Hz	250 Hz	500 Hz	1000 Hz	2000 Hz	4000 Hz	8000 Hz	
	Outlet	57.8	66.8	65.9	68.9	67.4	66.2	60.5	74.5
	Structure	46.7	62.0	63.6	63.5	62.5	58.6	51.9	69.4
	Inlet 57.8	57.8	66.8	65.9	68.9	67.4	66.2	60.5	74.5
Med.	L _w tot dB(A)	58.3	65.1	67.1	67.9	65.8	64.2	56.7	73
		125 Hz	250 Hz	500 Hz	1000 Hz	2000 Hz	4000 Hz	8000 Hz	
	Outlet	55.2	61.4	63.0	64.3	62.1	60.8	53.4	69.8
	Structure	44.1	56.5	60.7	58.9	57.2	53.2	44.8	65.0
	Inlet	55.2	61.4	63.0	64.3	62.1	60.8	53.4	69.8
Min.	L _w tot dB(A)	52.1	61.3	62.3	63.8	62.6	60.7	49.1	69
		125 Hz	250 Hz	500 Hz	1000 Hz	2000 Hz	4000 Hz	8000 Hz	
	Outlet	48.9	57.7	58.2	60.3	58.9	57.4	45.8	65.7
	Structure	37.8	52.8	55.9	54.8	54.0	49.7	37.2	60.9
	Inlet	48.9	57.7	58.2	60.3	58.9	57.4	45.8	65.7

NOTE

1. Sound power levels measured at ESP = 0 Pa.

4TW60227-1_F

9 Sound data

9 - 1 Sound Level Data

FWD18AT/AF									
FWD18AT/AF		125 Hz	250 Hz	500 Hz	1000 Hz	2000 Hz	4000 Hz	8000 Hz	Global Lw
Max.	Lw tot dB(A)	61.0	70.5	70.0	72.5	71.1	69.6	63.8	78
		125 Hz	250 Hz	500 Hz	1000 Hz	2000 Hz	4000 Hz	8000 Hz	
	Outlet	57.8	66.8	65.9	68.9	67.4	66.2	60.5	74.5
	Structure	46.7	62.0	63.6	63.5	62.5	58.6	51.9	69.4
	Inlet 57.8	66.8	65.9	68.9	67.4	66.2	60.5	74.5	
Med.	Lw tot dB(A)	58.3	65.1	67.1	67.9	65.8	64.2	56.7	73
		125 Hz	250 Hz	500 Hz	1000 Hz	2000 Hz	4000 Hz	8000 Hz	
	Outlet	55.2	61.4	63.0	64.3	62.1	60.8	53.4	69.8
	Structure	44.1	56.5	60.7	58.9	57.2	53.2	44.8	65.0
	Inlet	55.2	61.4	63.0	64.3	62.1	60.8	53.4	69.8
Min.	Lw tot dB(A)	52.1	61.3	62.3	63.8	62.6	60.7	49.1	69
		125 Hz	250 Hz	500 Hz	1000 Hz	2000 Hz	4000 Hz	8000 Hz	
	Outlet	48.9	57.7	58.2	60.3	58.9	57.4	45.8	65.7
	Structure	37.8	52.8	55.9	54.8	54.0	49.7	37.2	60.9
	Inlet	48.9	57.7	58.2	60.3	58.9	57.4	45.8	65.7

NOTE
1. Sound power levels measured at ESP = 0 Pa.

4TW60227-1

10 Installation

10 - 1 Installation Method

2
10

FWD-AT/AF

BEFORE THE INSTALLATION

The equipment is to be installed and serviced exclusively by technical personnel who are qualified for using this type of machine, in compliance with the relevant local and national regulations.

On receiving the equipment, check its state ensuring that it was not damaged during transport. Refer to the associated technical sheets for the installation and use instructions of any accessories.

INTENDED CONDITIONS OF USE AND OPERATING LIMITS

No responsibility is assumed if the equipment is installed by unqualified personnel, if it is used improperly or under inadmissible conditions, if maintenance is not performed as envisaged in this manual or if original spare parts are not used. For the operating limits please refer to the appropriate chapter. Any other use is considered improper.

Keep the equipment inside the packing until it is ready to be installed so that dust will not infiltrate.

Air sucked by the equipment must always be filtered. Use, when possible, the specific accessories.

If not used during the winter, drain the water from the system to prevent damage caused by the formation of ice. If antifreeze solutions are used, check the freezing point.

Do not change the internal wiring or other parts of the equipment.

INSTALLATION WARNING:

On the fan coil unit install a switch (IL) and/or all remote controls in a position out of the reach of persons who are in a bathtub or shower.

The FWD units may be installed either in horizontal or vertical position. Check that the desired installation complies with one of the diagrams shown in the installation manual, in which both possible configurations, M or AB, are suitable to work for heating and cooling.

AA (INTAKE IN LINE - DELIVERY IN LINE)

AB (AIR SUCTION AT 90° - AIR OUTLET IN LINE)

CONFIGURATION of the unit

The units are always supplied in AA configuration, but the air intake position may be changed during the installation.

FIXING the unit

Fix the standard unit to the ceiling or wall using at least 4 of the 6 slots.;

For horizontal installations (ceiling-mounting) it is advisable to use M8 threaded bars, screw anchors suitable for the machine's weight, and to arrange for the positioning of the machine using 2 M8 bolts and a washer the diameter of which is suitable for.

Before tightening the check nut, adjust the closing of the main nut so that the equipment will slant correctly, i.e. for facilitating the discharging of the condensate.

The correct slant is achieved by tilting the intake downwards as compared to the delivery, until a difference in level of about 10 mm is obtained from one end to the other. Make the hydraulic connections with the heat exchanger and, for cooling operations, with the condensate discharge.

Use one of the two drains of the auxiliary tank, visible on the outside of the unit's side panels and vertical condensate discharge.

For vertical installations (wall-mounting), fix the unit so that water may flow out toward the condensate discharge used. A slant equivalent to a difference in level of about 5 mm is enough between the two side panels. The two condensate discharge tubes of the main tank are located inside the side panels and may be accessed through a membrane type passage that should be perforated for passing the discharge tube through it. It is advisable not to remove the aforesaid passage because it prevents the sharp edge of the hole on the side panel from damaging the condensate discharge tube over time.

To connect the unit to the condensate discharge line, use a flexible rubber tube and fix it to the chosen discharge tube (f 3/8) by means of a metal clamp (use the discharge that is located on the hydraulic attachments side). To assist the draining of the condensate, slant the discharge tube downwards by at least 30 mm/m making sure that its entire route is clear and free from bends or blockages.

A few rules to follow

Carry out the heat exchanger's air exhaust, with pumps stopped, by means of the air valves located adjacent to the attachments of the heat exchanger itself.

4TW60229-3_A

10 Installation

10 - 1 Installation Method

FWD-AT/AF

When implementing a duct system, it is advisable to place the vibration-damping joints between the ducting and the unit. If you wish to install an electrical resistance module as accessory, the delivery vibration-damping joint should be heat-resistant. The ducting, especially the delivery one, should be insulated with anticondensing material.

Provide an inspection panel adjacent to the equipment for the maintenance and cleaning operations.

Install the control panel on the wall. Choose a position that is easy to access for the setting of the functions and, if contemplated, for the reading of the temperature. Try to avoid positions that are directly exposed to sun rays, or positions subject to direct hot or cold air currents, and do not place obstacles in the way that would prevent the correct reading of the temperature.

ELECTRICAL CONNECTIONS

Carry out the electrical wiring after having turned the power off in compliance with the relevant local and national regulations following the relevant wiring diagram.

Only qualified personnel should carry out the wiring operations.

Each fan coil requires a switch (IL) on the feeder line with a distance of at least 3 mm between the opening contacts, and a suitable safety fuse (F).

Power consumption is shown on the data plate fixed to the unit. Make sure to carefully execute the wiring in function of the combination unit/controller and this according to the correct wiring diagram delivered with every accessory. In order to make the electrical connections you must remove the lower closing panel to access the terminal board. The power cables (power supply and control) must be routed to the terminal board through the membrane passage that is on the side panel of the machine on the side opposite the hydraulic attachments.

WARNING

The COMMON wire of the motor is the WHITE one: if connected incorrectly the motor would be damaged irreparably.

FUNCTIONAL CHECKS

Check that the equipment has been installed so that it guarantees the required slant.

Check that the condensate discharge is not clogged (by rubble deposits, etc.).

Check the seal of the hydraulic connections.

Check that all the wirings are tight (perform the check with voltage OFF).

Make sure air has been purged from the heat exchanger.

Power the equipment and check its working efficiency.

10 Installation

10 - 1 Installation Method

FWD-AT/AF

1. Ducted unit with filter only

Consider at least:

- 500 mm free space on water connections side (piping & connections)
- 200 mm free space on the opposite side (to unscrew heat exchangers or fan deck in case of repairing)
- Possibility to extract filter for cleaning has to be considered
- Possibility to reach the unit for ordinary and extraordinary maintenance (for instance removing front panels) has to be considered
- 4TW60229

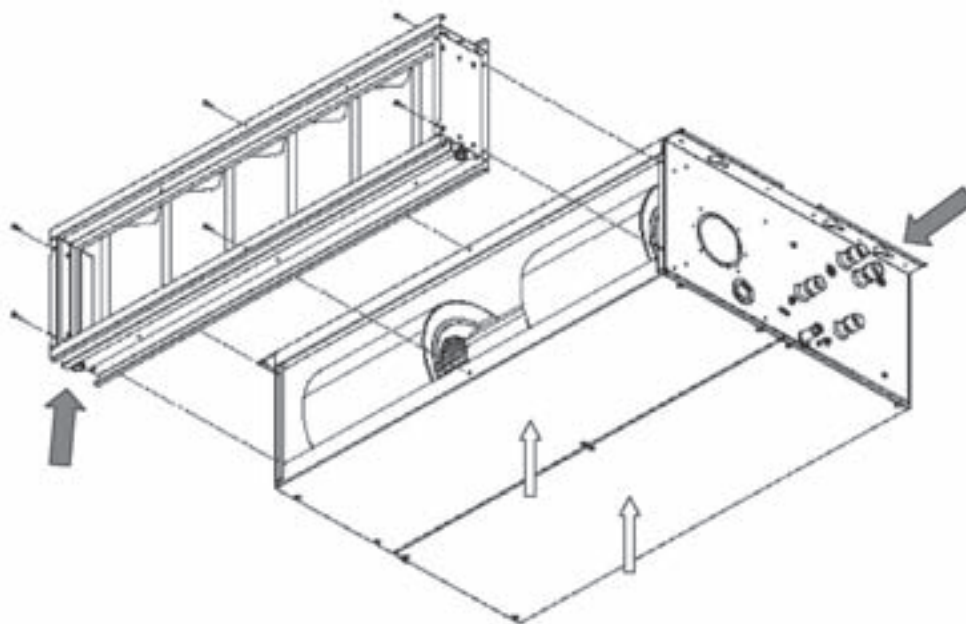

4TW60229-3_C

10 Installation

10 - 1 Installation Method

FWD-AT/AF

2. Ducted unit with filter and electric heater

Consider at least:

- 500 mm free space on water connections side (piping & connections), measured from the electrical box of the heating module (refer to option technical leaflet for details - total 620 mm)
- 200 mm free space on the opposite side (to unscrew heat exchangers or fan deck in case of repairing)
- Possibility to extract filter for cleaning has to be considered
- Possibility to reach the unit for ordinary and extraordinary maintenance (for instance removing front panels) has to be considered

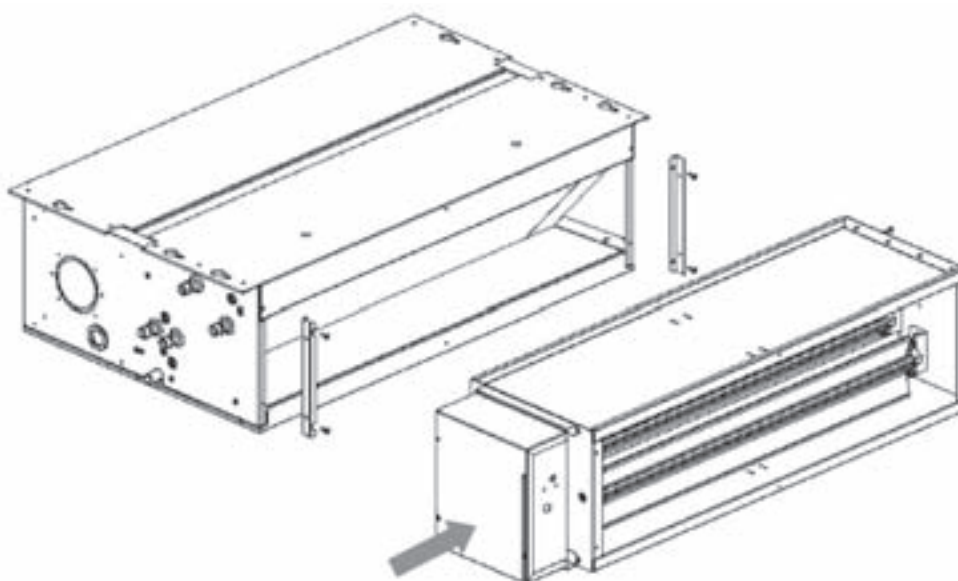

4TW60229-3_D

10 Installation

10 - 1 Installation Method

FWD-AT/AF

3. Ducted unit with filter and valves

Consider also:

- 500 mm free space on water connections side (piping & connections), measured from the valve piping (refer to option technical leaflet for details - total around 720 mm)
- 200 mm free space on the opposite side (to unscrew heat exchangers or fan deck in case of repairing)
- Possibility to extract filter for cleaning has to be considered
- Possibility to reach the unit for ordinary and extraordinary maintenance (for instance removing front panels) has to be considered

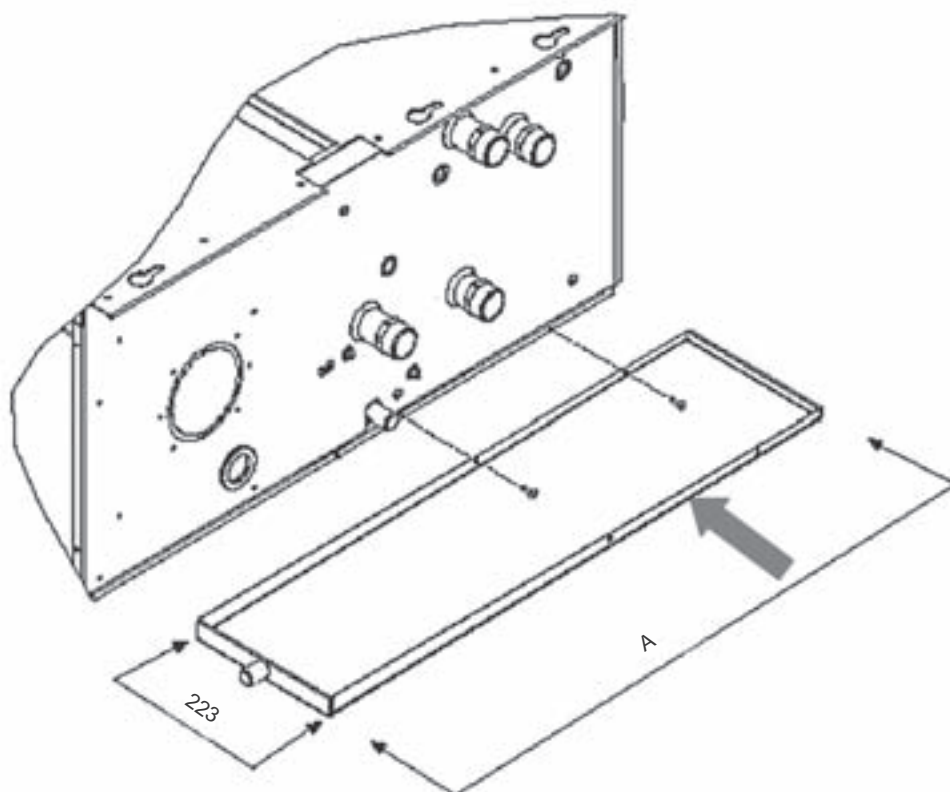

4TW60229-3_E

11 Operation range

11 - 1 Operation range

FWD-AT/AF

Minimum water temperature	+5°C
Maximum water temperature	+95°C
Maximum operating pressure	10 bar
Minimum air inlet temperature	-20°C
Maximum air inlet temperature	+43°C
Power supply	230V +10% / 1~ / 50Hz

4TW60223-1

12 Hydraulic performance

12 - 1 Water Pressure Drop Curve Evaporator

2
12

FWD-AT/AF

Water flow l/h	FWD-AT/AF						
	Water pressure drop						
	FWD04AT/AF	FWD06AT/AF	FWD08AT/AF	FWD10AT/AF	FWD12AT/AF	FWD16AT/AF	FWD18AT/AF
	kPa	kPa	kPa	kPa	kPa	kPa	kPa
100	0.59	0.37	0.25	0.13	0.13	0.09	0.1
200	2.02	1.25	0.84	0.45	0.43	0.32	0.35
300	4.12	2.57	1.72	0.92	0.88	0.65	0.71
400	6.83	4.27	2.86	1.53	1.47	1.08	1.19
500	10.12	6.32	4.24	2.27	2.19	1.6	1.76
600	13.94	8.71	5.85	3.14	3.02	2.22	2.44
700	18.28	11.42	7.67	4.12	3.97	2.92	3.2
800	23.12	14.45	9.69	5.21	5.02	3.69	4.06
900	28.45	17.77	11.92	6.41	6.17	4.55	5
1000	34.23	21.39	14.35	7.71	7.43	5.48	6.02
1100	40.48	25.29	16.97	9.11	8.79	6.47	7.11
1200	47.17	29.48	19.78	10.62	10.24	7.54	8.29
1300	54.29	33.94	22.77	12.23	11.78	8.68	9.54
1400	61.84	38.66	25.94	13.93	13.42	9.89	10.87
1500	69.81	43.65	29.28	15.73	15.16	11.16	12.27
1600	78.19	48.9	32.8	17.62	16.98	12.5	13.75
1700	86.97	54.4	36.5	19.6	18.89	13.91	15.3
1800	96.15	60.15	40.36	21.67	20.89	15.38	16.92
1900	105.73	66.15	44.38	23.83	22.97	16.92	18.61
2000	-	72.39	48.57	26.08	25.14	18.52	20.37
2100	-	78.88	52.93	28.42	27.4	20.18	22.19
2200	-	85.6	57.44	30.84	29.73	21.9	24.09
2300	-	92.55	62.11	33.35	32.15	23.68	26.05
2400	-	99.74	66.93	35.94	34.65	25.53	28.08
2500	-	107.16	71.91	38.62	37.23	27.43	30.17
3000	-	-	99.07	53.21	51.3	37.8	41.59
4000	-	-	-	88.2	85.07	62.71	69
5000	-	-	-	-	-	92.83	102.16

4TW60229-1_A

FWD-AT/AF

Water flow l/h	FWD-AT/AF						
	Water pressure drop						
	FWD04AT/AF	FWD06AT/AF	FWD08AT/AF	FWD10AT/AF	FWD12AT/AF	FWD16AT/AF	FWD18AT/AF
	kPa	kPa	kPa	kPa	kPa	kPa	kPa
100	0.51	0.32	0.22	0.12	0.11	0.08	0.09
200	1.68	1.07	0.72	0.39	0.38	0.28	0.31
300	3.4	2.16	1.46	0.78	0.76	0.56	0.62
400	5.6	3.56	2.4	1.29	1.25	0.93	1.03
500	8.25	5.24	3.53	1.9	1.84	1.37	1.51
600	11.33	7.18	4.84	2.61	2.53	1.88	2.07
700	14.81	9.39	6.32	3.4	3.3	2.45	2.71
800	18.69	11.83	7.97	4.29	4.16	3.09	3.41
900	22.95	14.52	9.77	5.26	5.1	3.79	4.18
1000	27.57	17.43	11.73	6.32	6.12	4.55	5.02
1100	32.55	20.57	13.85	7.46	7.22	5.36	5.91
1200	37.89	23.94	16.11	8.67	8.4	6.23	6.88
1300	43.56	27.51	18.51	9.97	9.65	7.14	7.9
1400	49.58	31.3	21.06	11.34	10.97	8.14	8.98
1500	55.92	35.29	23.74	12.78	12.37	9.17	10.12
1600	62.58	39.49	26.57	14.3	13.84	10.26	11.32
1700	69.57	43.89	29.52	15.89	15.37	11.4	12.57
1800	76.87	48.49	32.61	17.55	16.98	12.59	13.88
1900	84.48	53.28	35.83	19.28	18.65	13.83	15.24
2000	92.4	58.26	39.18	21.09	20.39	15.12	16.66
2100	100.61	63.43	42.66	22.95	22.2	16.45	18.14
2200	109.13	68.79	46.26	24.89	24.07	17.84	19.66
2300	-	74.34	49.99	26.9	26.01	19.27	21.24
2400	-	80.07	53.84	28.97	28.01	20.75	22.87
2500	-	85.97	57.81	31.1	30.08	22.28	24.55
3000	-	118.18	79.46	42.74	41.32	30.59	33.71
4000	-	-	-	70.61	68.24	50.5	55.63
5000	-	-	-	104.24	100.72	74.51	82.08

4TW60229-1_B

12 Hydraulic performance

12 - 1 Water Pressure Drop Curve Evaporator

FWD-AT/AF							
Water flow l/h	FWD-AT/AF						
	Water pressure drop						
	FWD04AT/AF	FWD06AT/AF	FWD08AT/AF	FWD10AT/AF	FWD12AT/AF	FWD16AT/AF	FWD18AT/AF
	kPa	kPa	kPa	kPa	kPa	kPa	kPa
100	0.83	0.71	0.35	0.35	0.13	0.1	0.1
200	2.75	2.36	1.16	1.16	0.42	0.33	0.33
300	5.55	4.76	2.34	2.34	0.85	0.67	0.67
400	9.14	7.84	3.84	3.84	1.39	1.1	1.1
500	13.48	11.54	5.65	5.65	2.05	1.61	1.61
600	18.51	15.83	7.75	7.75	2.81	2.21	2.21
700	24.21	20.7	10.13	10.13	3.66	2.88	2.88
800	30.56	26.1	12.77	12.77	4.62	3.63	3.63
900	37.52	32.04	15.68	15.68	5.66	4.45	4.45
1000	45.09	38.49	18.83	18.83	6.8	5.34	5.34
1100	53.25	45.44	22.22	22.22	8.02	6.29	6.29
1200	61.98	52.88	25.85	25.85	9.33	7.32	7.32
1300	71.27	60.8	29.72	29.72	10.72	8.41	8.41
1400	81.11	69.18	33.81	33.81	12.19	9.56	9.56
1500	91.5	78.03	38.13	38.13	13.74	10.78	10.78
1600	102.41	87.32	42.67	42.67	15.37	12.06	12.06
1700	-	97.06	47.42	47.42	17.08	13.39	13.39
1800	-	107.24	52.39	52.39	18.87	14.79	14.79
1900	-	-	57.57	57.57	20.73	16.25	16.25
2000	-	-	62.96	62.96	22.67	17.76	17.76
2500	-	-	92.92	92.92	33.44	26.19	26.19
3000	-	-	-	-	45.95	35.98	35.98
3500	-	-	-	-	60.12	47.06	47.06
4000	-	-	-	-	75.89	59.4	59.4
4500	-	-	-	-	93.21	72.95	72.95
5000	-	-	-	-	112.04	87.67	87.67

4TW60229-1_C



Daikin's unique position as a manufacturer of air conditioning equipment, compressors and refrigerants has led to its close involvement in environmental issues. For several years Daikin has had the intention to become a leader in the provision of products that have limited impact on the environment. This challenge demands the eco design and development of a wide range of products and an energy management system, resulting in energy conservation and a reduction of waste.



The present publication is drawn up by way of information only and does not constitute an offer binding upon Daikin Europe N.V. Daikin Europe N.V. has compiled the content of this publication to the best of its knowledge. No express or implied warranty is given for the completeness, accuracy, reliability or fitness for particular purpose of its content and the products and services presented therein. Specifications are subject to change without prior notice. Daikin Europe N.V. explicitly rejects any liability for any direct or indirect damage, in the broadest sense, arising from or related to the use and/or interpretation of this publication. All content is copyrighted by Daikin Europe N.V.

Daikin products are distributed by:



Daikin Europe N.V. is participating in the EUROVENT Certification Programme. Products are as listed in the EUROVENT Directory of Certified Products.

