

## Chillers

# Commercial and Technical Data

Water cooled condenserless chiller

- » **Wide capacity range  
(160kW – 520kW)**
- » **Indoor installations**
- » **Independent refrigerant  
circuits with single screw  
compressor**
- » **Water supply down  
to -8°C (optional)**
- » **New Microtech III  
controller**



ECDEN10-425

EWLD-G-  
160~520 kW

**R-134a**



Daikin Europe N.V.

## About Daikin

Daikin has a worldwide reputation based on over 85 years' experience in the successful manufacture of high quality air conditioning equipment for industrial, commercial and residential use. Daikin's much envied quality quite simply stems from the close attention paid to design, production and testing, as well as aftersales support. To this end, every component is carefully selected and rigorously tested to verify its contribution to product quality and reliability.

## New Daikin EWLD-G- range with upgraded controller

In order to upgrade the chiller portfolio with a superior control logic, Daikin enhances today the EWLD-G- remote condenser series incorporating the new Microtech III controller.

Microtech III ensures maximum efficiency and reliability, stable operating conditions and protection of critical components.

The EWLD-G- range is composed of 10 sizes and available in standard efficiency version. Each unit is equipped with one or two R-134a refrigerant circuits, featuring shell & tube evaporators and single screw compressors with stepless capacity control, allowing the unit to modulate its capacity from 100% to 12.5%.

Moreover, the range features an extensive option list, including the heat recovery and the low water leaving temperature version.



# Table of Contents

|  |    |
|--|----|
| CHILLER FEATURES                         | 2  |
| TECHNICAL DATA                           | 5  |
| 1. Features and advantages               | 5  |
| 2. General characteristics               | 7  |
| 3. Nomenclature                          | 11 |
| 4. Technical & electrical specifications | 12 |
| 5. Capacity tables                       | 14 |
| 6. Dimensional drawings                  | 16 |
| 7. Sound data .                          | 20 |
| 8. Installation                          | 22 |
| 9. Operation range                       | 23 |
| 10. Hydraulic performance                | 28 |
| 11. Specification text                   | 31 |



# Unit features

## Application flexibility

The EWLD-G- series is available in a wide range of capacities (160 - 520kW), making the units suitable for comfort and process cooling applications.

The most commonly serviced parts are easily accessible, simplifying maintenance and service. Moreover, the new chillers allow flexible integration into a wide range of control and building management systems.

## Large operation range

With the 'brine' option the new range is able to provide water down to  $-8^{\circ}\text{C}$ , making the units suitable also for some typical industrial applications.

## Superior control logic

The new Microtech III controller provides an easy to use control environmental. The control logic is designed to provide maximum efficiency, to continue operation in unusual operating conditions and to provide a history of unit operation. One of the greatest benefits is the easy interface with Lonwork, BACnet, Ethernet TCP/IP or Modbus communications.

## Extensive option list

The base model includes several standard factory mounted options such as: electronic expansion valve, suction line shut off valve, wye - delta starter, etc. Moreover, the new range features an extensive option list, including heat recovery, evaporator flow switch, soft starter, energy meter, etc.





# 1 Features and advantages

## Features and advantages

The water cooled screw chillers EWLD~G- are equipped with single screw compressors. They are manufactured to satisfy the requirements of the consultants and the end user. Units are designed to minimise energy costs while maximising the refrigeration capacities. Daikin's chiller design experience combined with outstanding features makes the EWLD~G- chiller unmatched in the industry.

### Seasonal quietness

The compressor design with a single screw and twin rotors allows a constant gas flow. This compression process completely eliminates gas pulsations. The oil injection also results in significant mechanical noise reduction. The twin gas compressor discharge chambers are designed to act as attenuators, based on the harmonic wave principle with destructive interference, thus always resulting equal to zero. The extremely low noise compressor performance affords the use of EWLD~G- chiller for all applications. The reduced number of vibrations produced from the EWLD~G- chiller offers a surprisingly quiet operation eliminating the noise transmission through the structure and the chilled water piping system.

### Infinitely capacity control

Cooling capacity control is infinitely variable by means of a screw compressor controlled by microprocessor system. Each unit has infinitely variable capacity control from 100% down to 25% (one compressor unit), down to 12,5% (two compressors units). This modulation allows the compressor capacity to exactly match the building cooling load without any leaving evaporator water temperature fluctuation. This chilled water temperature fluctuation is avoided only with a stepless control.

With a compressor load step control in fact, the compressor capacity, at partial loads, will be too high or too low compared to the building cooling load. The result is an increase in chiller energy costs, particularly at the part-load conditions at which the chiller operates most of the time.

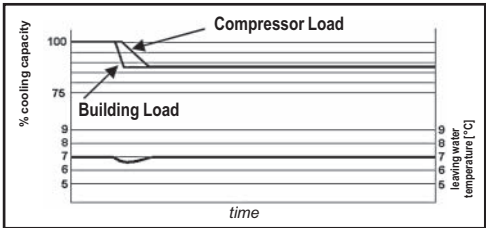

ELWT fluctuation with stepless capacity control

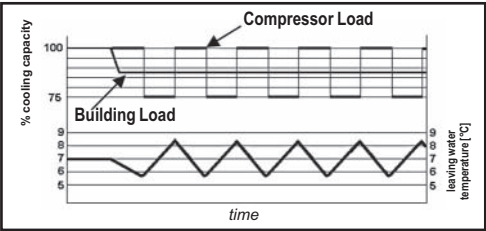

ELWT fluctuation with steps capacity control (4 steps)

Units with stepless regulation offer benefits that the units with step regulation are unable to match. The ability to follow the system energy demand at any time and the possibility to provide steady outlet water temperature without deviations from the set-point, are the two points that allow you to understand how the optimum operating conditions of a system can be met only through the use of a unit with step-less regulation.

### Unmatched serviceability

Field serviceability has not been sacrificed. Inspection covers allows visual inspection of the main screw and gaterotors.

# 1 Features and advantages

## Outstanding reliability features

### Unsurpassed Efficiency

- Zero clearance fit between the two gaterotors and main screw rotor virtually eliminates leakage between the high and low-pressure sides during compression. Special gaterotor material made from an advanced composite, temperature stable material makes a zero clearance design possible.
- The chiller is equipped with the most advanced means of refrigerant flow control available. An electronic expansion valve coupled with the MicroTech II C Plus controller's control logic provides excellent operating efficiencies both at full and part load operation.
- Infinite unloading matches compressor capacity to load.
- Full factory testing of the unit with water hookups helps provides a trouble-free start-up. Extensive quality control checks during testing means that each equipment protection and operating control is properly adjusted and operates correctly before it leaves the factory. Factory-installed options minimize field expenses and startup labor.
- The rugged design of the single-screw compressor allows it to be tolerant of liquid slugging.
- Very low loading enhances the bearing and compressor reliability. Due to symmetrical compression taking place on both sides of the main screw rotor, balanced forces result in the elimination of the large radial force loads inherent in twin-screw compressors.
- Integral to the basic design of the single-screw compressor, the main screw rotor shaft and the gaterotor shafts cross at right angles in the compressor. The result is ample space to locate heavy duty bearings and increase compressor reliability since no limitations are placed on bearing design as found in twin-screw compressors.

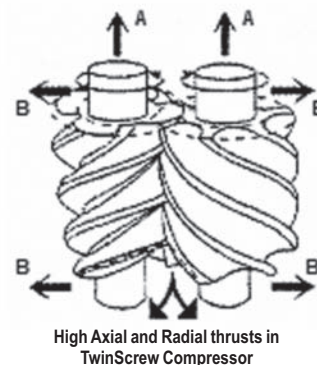
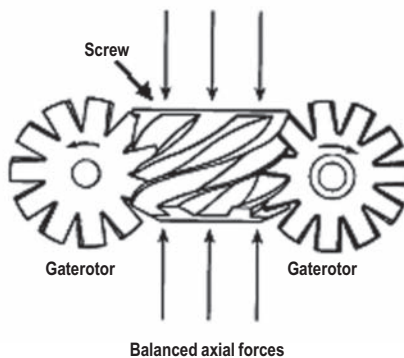
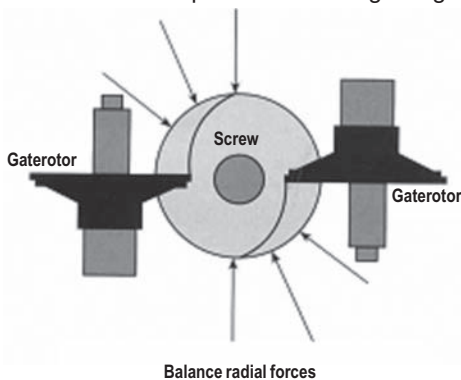

### Code requirements – Safety and observant of laws/directives

All water cooled units are designed and manufactured in accordance with applicable selections of the following:

|                                 |                            |
|---------------------------------|----------------------------|
| Construction of pressure vessel | 97/23/EC (PED)             |
| Machinery Directive             | 2006/42/EC                 |
| Low Voltage                     | 2006/95/EC                 |
| Electromagnetic Compatibility   | 2004/108/EC                |
| Electrical & Safety codes       | EN 60204-1 / EN 60335-2-40 |
| Manufacturing Quality Stds      | UNI – EN ISO 9001:2004     |

### Certifications

All units manufactured are CE marked, complying with European directives in force, concerning manufacturing and safety. On request units can be produced complying with laws in force in non European countries (ASME, GOST, etc.), and with other applications, such as naval (RINA, etc.).

### Versions

EWLD~G- is available in one Efficiency Version:

**S:** Standard Efficiency

10 sizes to cover a range from 161 up to 526 kW with an EER up to 3.70

The EER (Energy Efficiency Ratio) is the ratio of the Cooling Capacity to the Power Input of the unit. The Power Input includes: the power input for operation of the compressor, the power input of all control and safety devices.

### Sound Configuration

EWLD~G- is available in Standard sound level configuration:

**S:** Standard Noise

## 2 General characteristics

### General characteristics

#### Cabinet and structure

The cabinet is made of galvanized steel sheet and painted to provide a high resistance to corrosion. Colour Ivory White (Munsell code 5Y7.5/1) ( $\pm$ RAL7044). The base frame has eye-hook for lifting the unit with ropes for an easy installation. The weight is uniformly distributed along the profiles of the base and this facilitates the arrangement of the unit.

#### Screw compressors

The single-screw compressor has a well balanced compression mechanism which cancels the screw rotor load in both the radial and axial directions. Inherent to the basic single-screw compressor design is the virtually load-free operation that gives main bearing design life of 3-4 times greater than twin-screws, and eliminates expensive and complicated thrust balancing schemes. The two exactly opposed gate rotors create two exactly opposed compression cycles. Compression is made at the lower and upper parts of the screw rotor at the same time, thus cancelling the radial loads. Also, both ends of the screw rotor are subjected to suction pressure only, which cancels the axial loads and eliminates the huge thrust loads inherent in twin-screw compressors.

Oil injection is used for these compressors in order to get EER at high condensing pressure. The units are provided with a high efficiency oil separator to maximise oil extraction.

Compressors have an infinitely variable capacity control down to 25% of its total capacity. This control is made by means of capacity slides controlled by microprocessors.

Standard start is star-delta type; soft start type is available as option.

#### Ecological R-134a refrigerant

The compressors have been designed to operate with R-134a, ecological refrigerant with zero ODP (Ozone Depletion Potential) and very low GWP (Global Warming Potential) that means low TEWI (Total Equivalent Warming Impact).

#### Evaporator

The units are equipped with a Direct Expansion shell&tube evaporator with copper tubes rolled into steel tubesheets. The evaporators are single-pass on both the refrigerant and water sides for pure counter-flow heat exchange and low refrigerant pressure drops. Both attributes contribute to the heat exchanger effectiveness and total unit's outstanding efficiency.

The external shell is covered with a 10mm closed cell insulation material. Each evaporator has 1 circuit for each compressor and is manufactured in accordance to PED approval. The evaporator water outlet connections are provided with Victaulic Kit (as standard).

#### Electronic expansion valve

The unit is equipped with the most advanced electronic expansion valves to achieve precise control of refrigerant mass flow. As today's system requires improved energy efficiency, tighter temperature control, wider range of operating conditions and incorporate features like remote monitoring and diagnostics, the application of electronic expansion valves becomes mandatory. Electronic expansion valve proposes features that make it unique: short opening and closing time, high resolution, positive shut-off function to eliminate use of additional solenoid valve, highly linear flow capacity, continuous modulation of mass flow without stress in the refrigerant circuit and corrosion resistance stainless steel body.

EEXV strength point is the capacity to work with lower  $\Delta P$  between high and low pressure side, than a thermostatic expansion valve. The electronic expansion valve allows the system to work with low condenser pressure (winter time) without any refrigerant flow problems and with a perfect chilled water leaving temperature control.

#### Refrigerant Circuit

Each unit has independent refrigerant circuits and each one includes:

- Single screw compressor with external cyclonic oil separator
- (Common) Evaporator
- Oil pressure transducer
- High pressure switches
- High pressure transducer
- Low pressure transducer
- Moisture liquid indicator

GNC\_1-2-3-4\_Rev.00\_1



## 2 General characteristics

- High efficiency oil separator
- Replaceable core filter-drier
- Electronic expansion valve

### Electrical control panel

Power and control are located in the main panel that is manufactured to ensure protection against all weather conditions. The electrical panel is IP54 and (when opening the doors) internally protected with Plexiglas panel against possible accidental contact with electrical components (IP20). The main panel is fitted with a main switch interlocked door.

### Power Section

The power section includes compressors fuses and control circuit transformer.

### MicroTech III controller

MicroTech III controller is installed as standard; it can be used to modify unit set-points and check control parameters. A built-in display shows chiller operating status plus temperatures and pressures of water, refrigerant, programmable values, set-points. A sophisticated software with predictive logic, selects the most energy efficient combination of compressors and EEXV to keep stable operating conditions to maximise chiller energy efficiency and reliability.

MicroTech III is able to protect critical components based on external signs from its system (such as motor temperatures, refrigerant gas and oil pressures, correct phase sequence, pressure switches and evaporator). The input coming from the high pressure switch cuts all digital output from the controller in less than 50ms, this is an additional security for the equipment.

Fast program cycle (200ms) for a precise monitoring of the system. Floating point calculations supported for increased accuracy in P/T conversions.

### Control section - main features

- Management of the compressor stepless capacity.
- Chiller enabled to work in partial failure condition.
- Full routine operation at condition of:
  - high ambient temperature value
  - high thermal load
  - high evaporator entering water temperature (start-up)
- Display of evaporator entering/leaving water temperatures.
- Display of condensing-evaporating temperatures and pressures, suction and discharge superheat for each circuit.
- Leaving water evaporator temperature regulation. Temperature tolerance = 0.1°C.
- Compressor and evaporator pumps hour counters.
- Display of Status Safety Devices.
- Number of starts and compressor working hours.
- Optimized management of compressor load.
- Re-start in case of power failure (automatic / manual).
- Soft Load (optimized management of the compressor load during the start-up).
- Start at high evaporator water temperature.
- Return Reset (Set Point Reset based on return water temperature).
- Set point Reset.
- Application and system upgrade with commercial SD cards.
- Ethernet port for remote or local servicing using standard web browsers.
- Two different sets of default parameters could be stored for easy restore.

## 2 General characteristics

### Safety device / logic for each refrigerant circuit

- High pressure (pressure switch).
- High pressure (transducer).
- Low pressure (transducer).
- High compressor discharge temperature.
- High motor winding temperature.
- Phase Monitor.
- Low pressure ratio.
- High oil pressure drop
- Low oil pressure.
- No pressure change at start.

### System security

- Phase monitor.
- Low Ambient temperature lock-out.
- Freeze protection.

### Regulation type

Proportional + integral + derivative regulation on the evaporator leaving water output probe.

### MicroTech III

MicroTech III built-in terminal has the following features.

- 164x44 dots liquid crystal display with white back lighting. Supports Unicode fonts for multi-lingual.
- Key-pad consisting of 3 keys.
- Push'n'Roll control for an increased usability.
- Memory to protect the data.
- General faults alarm relays.
- Password access to modify the setting.
- Application security to prevent application tampering or hardware usability with third party applications.
- Service report displaying all running hours and general conditions.
- Alarm history memory to allow an easy fault analysis.

### Supervising systems (on request)

#### MicroTech III remote control

MicroTech III is able to communicate to BMS (Building Management System) based on the most common protocols as:

- ModbusRTU
- LonWorks, now also based on the international 8040 Standard Chiller Profile and LonMark Technology
- BacNet BTP certified over IP and MS/TP (class 4) (Native)

#### Chiller Sequencing

MicroTech III controller allows an easy plug-in sequencing technology based on digital or serial panel

#### Digital Sequencing Panel

This panel is basically a step inserter that switches ON/OFF up to 11 units (chillers or heat pumps operating in the same cooling/heating mode) depending on the selected set point; the units are connected with the panel through standard cables and no serial card is requested.

#### Serial Sequencing Panel

Basically this panel sequences a chiller plant by switching on/off the units (up to 7 chillers) taking into account their running hours and the requested plant load, in order to optimise the number of working units for each condition; serial cards and shielded cables are requested to connect the panel with the units and, if installed, a BMS.

GNC\_1-2-3-4\_Rev.00\_3

## 2 General characteristics

### Standard accessories (supplied on basic unit)

**Evaporator Victaulic Kit** - Hydraulic joint with gasket for an easy and quick water connection.

**Evaporator Water side design pressure 10 bar**

**Electronic Expansion Device**

**Suction line shut off valve** - Suction shut-off valve installed on the suction of the compressor to facilitate maintenance operation.

**Y-D starter** - Star Delta starter is the standard type

**Double set-point** - Dual leaving water temperature set-points.

**Phase monitor** - The phase monitor controls that phases sequence is correct and controls phase loss.

**High Pressure Side Manometers**

**Hour Run meter** - Digital compressors hour run meter

**General fault contactor** - Contactor for alarm warning.

**Set-point reset, demand limit and alarm from external device** - The leaving water temperature set-point can be overwritten with the following options: 4-20mA from external source (by user); outside ambient temperature; evaporator water temperature  $\Delta t$ . Moreover the device allow the user to limit the load of the unit by 4-20mA signal or by network system and the microprocessor is able to receive an alarm signal from an external device (pump etc... - user can decide if this alarm signal will stop the unit or not).

### Options (on request)

**Partial heat recovery** - Produced with plate to plate heat exchangers installed on discharge side of compressor hot gas. These allow hot water to be produced up to a maximum temperature of +50°C.

**Brine version** - Allows the unit to operate down to -8°C leaving liquid temperature (antifreeze required).

**20mm Evaporator Insulation**

**Sound proof system** - Made of sheet metal and internally insulated, the cabinet is "integral kind" (around the whole chiller, not only around the compressors) to reach the best performance in noise reduction.

**Dual pressure relief valve on evaporator**

**Soft start** - Electronic starting device to reduce the mechanical stress during compressor start-up

**Compressor thermal overload relays** - Safety devices against compressor motor overloading in addition to the normal protection envisaged by the electrical windings.

**Under/Over Voltage** - This device control the voltage value of power supply and stop the chiller if the value exceeds the allowed operating limits.

**Energy Meter** - This device allows to measure the energy absorbed by the chiller during its life. It is installed inside the control box mounted on a DIN rail and show on a digital display: Line-to-Line Voltage, Phase and Average Current, Active and Reactive Power, Active Energy, Frequency.

**Capacitors Cosfi 0.9** - Installed on the electrical control panel to ensure it conforms to the plant rules (advise: maximum 0,9).

**Current Limit** - To limit maximum absorbed current of the unit whenever is required.

Evaporator flow switch for the water piping

**Rubber type antivibration mounts** - Supplied separately, these are positioned under the base of the unit during installation. Ideal to reduce the vibrations when the unit is floor mounted.

**Forklift kit**

**Witness test** - Every unit is always tested at the test bench prior to the shipment. On request, a second test can be carried out, at customer's presence, in accordance with the procedures indicated on the test form. (Not available for units with glycol mixtures).

**Acoustic test**

### 3 Nomenclature

#### 3 - 1 Nomenclature

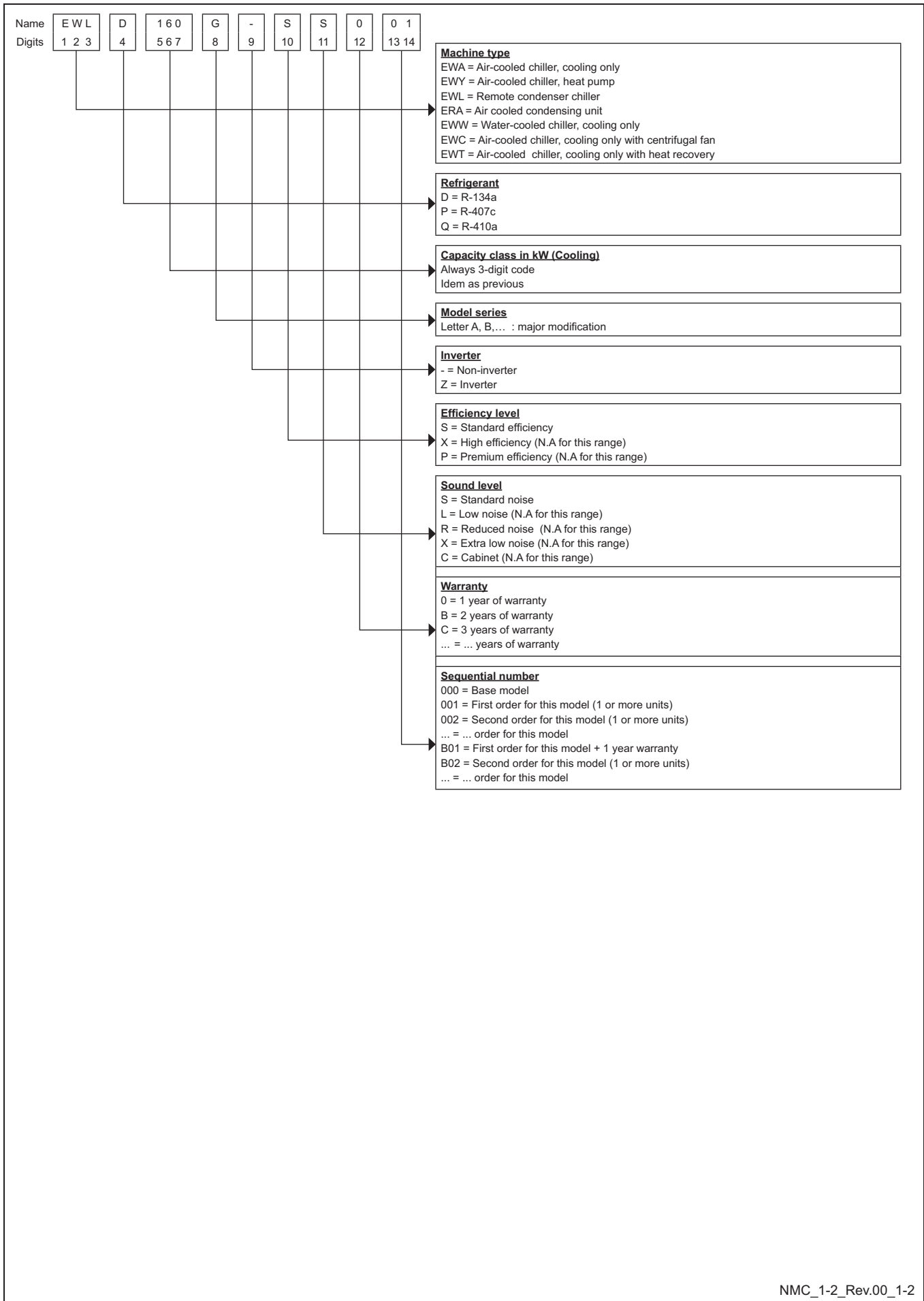

## 4 Technical & Electrical specifications

### 4 - 1 Technical specifications

| 4-1 Technical specifications      |                               |                |   | 160                                   | 190      | 240      | 280       | 320      | 360      | 380      | 420       | 480      | 550       |         |
|-----------------------------------|-------------------------------|----------------|---|---------------------------------------|----------|----------|-----------|----------|----------|----------|-----------|----------|-----------|---------|
| Cooling capacity                  | Nom.                          | kW             |   | 161 (1)                               | 189 (1)  | 244 (1)  | 270.0 (1) | 316 (1)  | 352 (1)  | 381 (1)  | 428 (1)   | 476 (1)  | 526 (1)   |         |
| Capacity control                  | Method                        |                |   | Stepless                              |          |          |           |          |          |          |           |          |           |         |
|                                   | Minimum capacity              |                | %   | 25                                    |          |          |           |          | 12.5     |          |           |          |           |         |
| Power input                       | Cooling                       | Nom.           | kW  |                                       | 45.4 (1) | 54.3 (1) | 65.9 (1)  | 74.6 (1) | 90.6 (1) | 99.7 (1) | 108.6 (1) | 120 (1)  | 131.5 (1) | 148 (1) |
| EER                               |                               |                |   | 3.54 (1)                              | 3.48 (1) | 3.70 (1) | 3.62 (1)  | 3.48 (1) | 3.53 (1) | 3.51 (1) | 3.57 (1)  | 3.62 (1) | 3.55 (1)  |         |
| Casing                            | Colour                        |                |   | Ivory white                           |          |          |           |          |          |          |           |          |           |         |
|                                   | Material                      |                |   | Galvanized and painted steel sheet    |          |          |           |          |          |          |           |          |           |         |
| Dimensions                        | Unit                          | Height         | mm  | 1,860                                 |          |          |           |          | 1,942    |          |           |          |           |         |
|                                   |                               | Width          | mm  | 1,000                                 |          |          |           |          | 1,100    |          |           |          |           |         |
|                                   |                               | Depth          | mm  | 3,700                                 |          |          |           |          | 4,400    |          |           |          |           |         |
| Weight                            | Unit                          |                | kg  | 1,280                                 |          | 1,398    |           | 2,442    | 2,446    |          | 2,501     | 2,506    |           |         |
|                                   | Operation weight              |                | kg  | 1,337                                 |          | 1,516    |           | 2,560    |          | 2,670    |           |          |           |         |
| Water heat exchanger - evaporator | Water volume                  |                |   | l                                     | 60       | 56       | 123       |          | 118      | 113      |           | 173      | 168       |         |
|                                   | Water flow rate               | Nom.           | l/min   | 462                                   | 540      | 702      | 774       | 906      | 1,008    | 1,092    | 1,230     | 1,362    | 1,506     |         |
|                                   | Nominal water pressure drop   | Cooling        | Heat exchanger                                | kPa                                   | 44       | 60       | 41        | 49       | 57       | 55.9     | 64.4      | 49.9     | 50.6      | 60.6    |
|                                   | Insulation material           |                |   | Closed cell                           |          |          |           |          |          |          |           |          |           |         |
|                                   | Type                          |                |   | Single pass shell and tube            |          |          |           |          |          |          |           |          |           |         |
| Sound power level                 | Cooling                       | Nom.           | dBA   | 87.7                                  |          |          |           |          | 90.2     |          |           |          |           |         |
| Sound pressure level              | Cooling                       | Nom.           | dBA   | 69.7                                  |          |          |           |          | 71.7     |          |           |          |           |         |
| Compressor                        | Type                          |                |   | Semi-hermetic single screw compressor |          |          |           |          |          |          |           |          |           |         |
|                                   | Quantity                      |                |   | 1                                     |          |          |           |          | 2        |          |           |          |           |         |
|                                   | Oil                           | Charged volume |   | l                                     | 16       |          |           |          |          | 32       |           |          |           |         |
| Operation range                   | Evaporator                    | Cooling        | Min.  | °CDB                                  | -8       |          |           |          |          |          |           |          |           |         |
|                                   |                               |                | Max.  | °CDB                                  | 15       |          |           |          |          |          |           |          |           |         |
|                                   | Condenser                     | Cooling        | Min.  | °CDB                                  | 25       |          |           |          |          |          |           |          |           |         |
|                                   |                               |                | Max.  | °CDB                                  | 60       |          |           |          |          |          |           |          |           |         |
| Refrigerant                       | Type                          |                |   | R-134a                                |          |          |           |          |          |          |           |          |           |         |
|                                   | Circuits                      | Quantity       |   | 1                                     |          |          |           |          | 2        |          |           |          |           |         |
| Piping connections                | Liquid line connection        |                | mm  | 42                                    |          |          |           |          |          |          |           |          |           |         |
|                                   | Evaporator water inlet/outlet |                |   | 88.9                                  | 114.3    |          |           |          |          | 139.7mm  |           |          |           |         |
| Safety devices                    | Item                          | 01             | High discharge pressure (pressure switch)     |                                       |          |          |           |          |          |          |           |          |           |         |
|                                   |                               | 02             | High discharge pressure (pressure transducer) |                                       |          |          |           |          |          |          |           |          |           |         |
|                                   |                               | 03             | Low suction pressure (pressure transducer)    |                                       |          |          |           |          |          |          |           |          |           |         |
|                                   |                               | 04             | Compressor motor protection                   |                                       |          |          |           |          |          |          |           |          |           |         |
|                                   |                               | 05             | High discharge temperature                    |                                       |          |          |           |          |          |          |           |          |           |         |
|                                   |                               | 06             | Refrigerant in oil sump                       |                                       |          |          |           |          |          |          |           |          |           |         |
|                                   |                               | 07             | Low oil pressure                              |                                       |          |          |           |          |          |          |           |          |           |         |
|                                   |                               | 08             | Low pressure ratio                            |                                       |          |          |           |          |          |          |           |          |           |         |
|                                   |                               | 09             | High oil filter pressure drop                 |                                       |          |          |           |          |          |          |           |          |           |         |
|                                   |                               | 10             | Phase monitor                                 |                                       |          |          |           |          |          |          |           |          |           |         |
|                                   |                               | 11             | Flowswitch                                    |                                       |          |          |           |          |          |          |           |          |           |         |
|                                   |                               | 12             | Emergency stop                                |                                       |          |          |           |          |          |          |           |          |           |         |
|                                   |                               | 13             | Water freeze protection controller            |                                       |          |          |           |          |          |          |           |          |           |         |



## 4 Technical & Electrical specifications

### 4 - 2 Electrical specifications

| 4-2 Electrical Specifications |                                   |         |    | 160       | 190 | 240 | 280 | 320 | 360 | 380 | 420 | 480 | 550 |
|-------------------------------|-----------------------------------|---------|----|-----------|-----|-----|-----|-----|-----|-----|-----|-----|-----|
| Compressor                    | Phase                             |         |    | 3~        |     |     |     |     |     |     |     |     |     |
|                               | Voltage                           |         | V  | 400       |     |     |     |     |     |     |     |     |     |
|                               | Voltage range                     | Min.    | %  | -10       |     |     |     |     |     |     |     |     |     |
|                               |                                   | Max.    | %  | 10        |     |     |     |     |     |     |     |     |     |
|                               | Maximum running current           |         | A  | 112       | 134 | 161 | 182 | 112 |     | 134 |     | 161 | 182 |
|                               | Starting method                   |         |    | Wye-delta |     |     |     |     |     |     |     |     |     |
| Compressor 2                  | Maximum running current           |         | A  | -         |     |     | 112 |     | 134 |     | 161 | 182 |     |
| Power supply                  | Phase                             |         |    | 3         |     |     |     |     |     |     |     |     |     |
|                               | Frequency                         |         | Hz | 50        |     |     |     |     |     |     |     |     |     |
|                               | Voltage                           |         | V  | 400       |     |     |     |     |     |     |     |     |     |
|                               | Voltage range                     | Min.    | %  | -10       |     |     |     |     |     |     |     |     |     |
|                               |                                   | Max.    | %  | 10        |     |     |     |     |     |     |     |     |     |
| Unit                          | Maximum starting current          |         | A  | 288       |     |     | 378 |     | 395 |     | 417 | 434 |     |
|                               | Nominal running current (RLA)     | Cooling | A  | 79        | 90  | 107 | 120 | 157 | 169 | 181 | 197 | 214 | 239 |
|                               |                                   |         | A  | 112       | 134 | 161 | 182 | 224 | 246 | 268 | 295 | 343 | 364 |
|                               | Max unit current for wires sizing |         | A  | 123       | 147 | 177 | 200 | 246 | 271 | 295 | 325 | 377 | 400 |

#### Notes

- (1) Cooling: entering evaporator water temp. 12°C; leaving evaporator water temp. 7°C; saturated discharge temp. at the compressor 45°C.
- (2) Sound level data are measured at entering evaporator water temp. 12°C; leaving evaporator water temp. 7°C; saturated discharge temp. 45°C; full load operation; standard: ISO3744
- (3) Units are shipped with holding nitrogen charge at 2 bar
- (4) Allowed voltage tolerance  $\pm 10\%$ . Voltage unbalance between phases must be within  $\pm 3\%$ .
- (5) Maximum starting current: starting current of biggest compressor + current of the other compressor at 75 % of maximum load
- (6) Maximum running current is based on max compressor absorbed current in its envelope
- (7) Maximum unit current for wires sizing is based on minimum allowed voltage.
- (8) Maximum current for wires sizing: (compressors full load ampere + fans current) x 1.1

# 5 Capacity tables

## 5 - 1 Cooling capacity tables

| EWLD160-320G-SS |           |                                      |         |         |         |         |         |         |         |         |         |         |         |         |         |         |     |
|-----------------|-----------|--------------------------------------|---------|---------|---------|---------|---------|---------|---------|---------|---------|---------|---------|---------|---------|---------|-----|
| Size            | ELWT (°C) | Saturated Discharge Temperature (°C) |         |         |         |         |         |         |         |         |         |         |         |         |         |         |     |
|                 |           | 40                                   |         |         | 45      |         |         | 50      |         |         | 55      |         |         | 60      |         |         |     |
|                 |           | Cc (kW)                              | Pi (kW) | Hc (kW) | Cc (kW) | Pi (kW) | Hc (kW) | Cc (kW) | Pi (kW) | Hc (kW) | Cc (kW) | Pi (kW) | Hc (kW) | Cc (kW) | Pi (kW) | Hc (kW) |     |
| 160             | 4         | 152                                  | 40.1    | 192     | 145     | 45.1    | 190     | 138     | 50.5    | 189     | 131     | 56.4    | 187     | 123     | 62.8    | 186     |     |
|                 | 5         | 157                                  | 40.1    | 197     | 150     | 45.2    | 196     | 143     | 50.6    | 194     | 136     | 56.5    | 192     | 128     | 62.9    | 191     |     |
|                 | 6         | 163                                  | 40.2    | 203     | 155     | 45.3    | 201     | 148     | 50.7    | 199     | 140     | 56.6    | 197     | 132     | 63.0    | 195     |     |
|                 | 7         | 168                                  | 40.3    | 208     | 161     | 45.4    | 206     | 153     | 50.8    | 204     | 145     | 56.7    | 202     | 137     | 63.1    | 200     |     |
|                 | 8         | 173                                  | 40.4    | 214     | 166     | 45.5    | 211     | 158     | 50.9    | 209     | 150     | 56.8    | 207     | 142     | 63.2    | 205     |     |
|                 | 9         | 179                                  | 40.4    | 219     | 171     | 45.6    | 217     | 163     | 51.1    | 215     | 155     | 57.0    | 212     | 147     | 63.3    | 210     |     |
|                 | 10        | 184                                  | 40.5    | 225     | 177     | 45.7    | 223     | 169     | 51.2    | 220     | 161     | 57.1    | 218     | 152     | 63.5    | 216     |     |
|                 | 11        | 190                                  | 40.6    | 231     | 182     | 45.8    | 228     | 174     | 51.3    | 226     | 166     | 57.2    | 223     | 157     | 63.6    | 221     |     |
|                 | 12        | 196                                  | 40.6    | 237     | 188     | 45.8    | 234     | 180     | 51.4    | 231     | 171     | 57.4    | 229     | 163     | 63.7    | 226     |     |
|                 | 13        | 202                                  | 40.7    | 243     | 194     | 45.9    | 240     | 186     | 51.5    | 237     | 177     | 57.5    | 234     | 168     | 63.9    | 232     |     |
|                 | 14        | 208                                  | 40.7    | 249     | 200     | 46.0    | 246     | 191     | 51.6    | 243     | 183     | 57.6    | 240     | 173     | 64.0    | 237     |     |
|                 | 15        | 214                                  | 40.7    | 255     | 206     | 46.1    | 252     | 197     | 51.7    | 249     | 188     | 57.7    | 246     | 179     | 64.2    | 243     |     |
|                 | 190       | 4                                    | 179     | 47.9    | 227     | 172     | 53.9    | 225     | 163     | 60.4    | 224     | 155     | 67.5    | 222     | 145     | 75.1    | 220 |
|                 |           | 5                                    | 185     | 48.0    | 233     | 177     | 54.0    | 231     | 169     | 60.5    | 229     | 160     | 67.6    | 228     | 150     | 75.2    | 226 |
|                 |           | 6                                    | 191     | 48.1    | 239     | 183     | 54.1    | 237     | 175     | 60.7    | 235     | 165     | 67.7    | 233     | 156     | 75.3    | 231 |
| 7               |           | 197                                  | 48.2    | 246     | 189     | 54.3    | 243     | 180     | 60.8    | 241     | 171     | 67.8    | 239     | 161     | 75.4    | 237     |     |
| 8               |           | 204                                  | 48.3    | 252     | 195     | 54.4    | 249     | 186     | 60.9    | 247     | 177     | 68.0    | 245     | 167     | 75.5    | 242     |     |
| 9               |           | 210                                  | 48.4    | 258     | 201     | 54.5    | 256     | 192     | 61.1    | 253     | 183     | 68.1    | 251     | 173     | 75.7    | 248     |     |
| 10              |           | 216                                  | 48.4    | 265     | 208     | 54.6    | 262     | 198     | 61.2    | 260     | 189     | 68.3    | 257     | 178     | 75.8    | 254     |     |
| 11              |           | 223                                  | 48.5    | 271     | 214     | 54.7    | 269     | 205     | 61.3    | 266     | 195     | 68.4    | 263     | 184     | 76.0    | 260     |     |
| 12              |           | 229                                  | 48.6    | 278     | 220     | 54.8    | 275     | 211     | 61.4    | 272     | 201     | 68.5    | 269     | 190     | 76.1    | 266     |     |
| 13              |           | 236                                  | 48.7    | 285     | 227     | 54.9    | 282     | 217     | 61.6    | 279     | 207     | 68.7    | 276     | 196     | 76.3    | 273     |     |
| 14              |           | 243                                  | 48.7    | 292     | 234     | 55.0    | 289     | 224     | 61.7    | 286     | 214     | 68.8    | 282     | 203     | 76.5    | 279     |     |
| 15              |           | 250                                  | 48.8    | 299     | 241     | 55.1    | 296     | 231     | 61.8    | 292     | 220     | 69.0    | 289     | 209     | 76.6    | 286     |     |
| 240             |           | 4                                    | 231     | 58.1    | 289     | 221     | 65.4    | 286     | 210     | 73.3    | 283     | 199     | 81.8    | 281     | 187     | 91.0    | 278 |
|                 |           | 5                                    | 239     | 58.3    | 297     | 228     | 65.6    | 294     | 217     | 73.5    | 291     | 206     | 82.0    | 288     | 194     | 91.2    | 285 |
|                 |           | 6                                    | 247     | 58.4    | 305     | 236     | 65.7    | 302     | 225     | 73.6    | 299     | 213     | 82.2    | 295     | 201     | 91.3    | 292 |
|                 | 7         | 255                                  | 58.5    | 313     | 244     | 65.9    | 310     | 233     | 73.8    | 306     | 221     | 82.3    | 303     | 208     | 91.5    | 299     |     |
|                 | 8         | 263                                  | 58.6    | 322     | 252     | 66.0    | 318     | 240     | 74.0    | 314     | 228     | 82.5    | 311     | 215     | 91.7    | 307     |     |
|                 | 9         | 272                                  | 58.7    | 330     | 260     | 66.1    | 326     | 248     | 74.1    | 323     | 236     | 82.7    | 319     | 223     | 91.8    | 314     |     |
|                 | 10        | 280                                  | 58.8    | 339     | 269     | 66.3    | 335     | 257     | 74.3    | 331     | 244     | 82.8    | 327     | 230     | 92.0    | 322     |     |
|                 | 11        | 289                                  | 58.9    | 348     | 277     | 66.4    | 344     | 265     | 74.4    | 339     | 252     | 83.0    | 335     | 238     | 92.2    | 330     |     |
|                 | 12        | 298                                  | 58.9    | 357     | 286     | 66.5    | 353     | 273     | 74.6    | 348     | 260     | 83.2    | 343     | 246     | 92.4    | 338     |     |
|                 | 13        | 307                                  | 59.0    | 366     | 295     | 66.6    | 361     | 282     | 74.7    | 357     | 269     | 83.4    | 352     | 254     | 92.6    | 347     |     |
|                 | 14        | 316                                  | 59.0    | 375     | 304     | 66.7    | 371     | 291     | 74.9    | 366     | 277     | 83.6    | 361     | 262     | 92.8    | 355     |     |
|                 | 15        | 326                                  | 59.1    | 385     | 313     | 66.8    | 380     | 300     | 75.0    | 375     | 286     | 83.7    | 370     | 271     | 93.0    | 364     |     |
|                 | 280       | 4                                    | 257     | 66.5    | 323     | 245     | 72.6    | 318     | 233     | 79.5    | 313     | 221     | 87.3    | 308     | 208     | 96.0    | 304 |
|                 |           | 5                                    | 265     | 67.2    | 332     | 253     | 73.3    | 327     | 241     | 80.1    | 321     | 228     | 87.8    | 316     | 215     | 96.4    | 311 |
|                 |           | 6                                    | 274     | 67.9    | 342     | 262     | 73.9    | 336     | 249     | 80.7    | 330     | 236     | 88.4    | 325     | 223     | 96.9    | 320 |
| 7               |           | 283                                  | 68.7    | 351     | 270     | 74.6    | 345     | 258     | 81.3    | 339     | 245     | 88.9    | 333     | 231     | 97.4    | 328     |     |
| 8               |           | 292                                  | 69.4    | 361     | 279     | 75.3    | 355     | 266     | 82.0    | 348     | 253     | 89.5    | 342     | 239     | 98.0    | 337     |     |
| 9               |           | 301                                  | 70.2    | 371     | 288     | 76.1    | 364     | 275     | 82.7    | 358     | 261     | 90.2    | 352     | 247     | 98.5    | 345     |     |
| 10              |           | 310                                  | 71.1    | 381     | 297     | 76.8    | 374     | 284     | 83.4    | 367     | 270     | 90.8    | 361     | 255     | 99.1    | 354     |     |
| 11              |           | 320                                  | 71.9    | 391     | 307     | 77.6    | 384     | 293     | 84.1    | 377     | 279     | 91.5    | 370     | 264     | 100     | 364     |     |
| 12              |           | 329                                  | 72.8    | 402     | 316     | 78.5    | 394     | 302     | 84.9    | 387     | 288     | 92.2    | 380     | 273     | 100     | 373     |     |
| 13              |           | 339                                  | 73.7    | 413     | 326     | 79.3    | 405     | 312     | 85.7    | 397     | 297     | 93.0    | 390     | 281     | 101     | 383     |     |
| 14              |           | 349                                  | 74.7    | 424     | 335     | 80.2    | 416     | 321     | 86.5    | 408     | 306     | 93.7    | 400     | 290     | 102     | 392     |     |
| 15              |           | 359                                  | 75.6    | 435     | 345     | 81.1    | 426     | 331     | 87.4    | 418     | 316     | 94.5    | 410     | 300     | 103     | 402     |     |
| 320             |           | 4                                    | 299     | 80.0    | 379     | 286     | 90.0    | 376     | 272     | 101     | 373     | 258     | 113     | 370     | 243     | 126     | 368 |
|                 |           | 5                                    | 309     | 80.2    | 389     | 296     | 90.2    | 386     | 282     | 101     | 383     | 267     | 113     | 380     | 252     | 126     | 377 |
|                 |           | 6                                    | 319     | 80.3    | 400     | 305     | 90.4    | 396     | 291     | 101     | 392     | 276     | 113     | 389     | 261     | 126     | 387 |
|                 | 7         | 330                                  | 80.5    | 410     | 316     | 90.6    | 406     | 301     | 102     | 402     | 286     | 113     | 399     | 270     | 126     | 396     |     |
|                 | 8         | 340                                  | 80.7    | 421     | 326     | 90.8    | 417     | 311     | 102     | 413     | 295     | 114     | 409     | 279     | 126     | 406     |     |
|                 | 9         | 351                                  | 80.8    | 432     | 336     | 91.0    | 427     | 321     | 102     | 423     | 305     | 114     | 419     | 289     | 127     | 416     |     |
|                 | 10        | 362                                  | 80.9    | 443     | 347     | 91.2    | 438     | 331     | 102     | 434     | 315     | 114     | 430     | 299     | 127     | 426     |     |
|                 | 11        | 373                                  | 81.1    | 454     | 358     | 91.4    | 449     | 342     | 102     | 444     | 326     | 114     | 440     | 309     | 127     | 436     |     |
|                 | 12        | 384                                  | 81.2    | 465     | 369     | 91.6    | 460     | 353     | 103     | 456     | 336     | 115     | 451     | 319     | 127     | 446     |     |
|                 | 13        | 396                                  | 81.3    | 477     | 380     | 91.7    | 472     | 364     | 103     | 467     | 347     | 115     | 462     | 330     | 128     | 457     |     |
|                 | 14        | 408                                  | 81.3    | 489     | 392     | 91.9    | 484     | 375     | 103     | 478     | 358     | 115     | 473     | 340     | 128     | 468     |     |
|                 | 15        | 420                                  | 81.4    | 501     | 403     | 92.0    | 495     | 387     | 103     | 490     | 369     | 115     | 484     | 351     | 128     | 479     |     |

**NOTES**

Cc (cooling capacity) - Pi (unit power input) - Hc (heating capacity) - ELWT (evaporator leaving water temperature - Δt 5°C)  
 Data are referred to 0.0176 m<sup>2</sup> °C/kW evaporator fouling factor

# 5 Capacity tables

## 5 - 1 Cooling capacity tables

| EWLD360-550G-SS |           |  |         |         |         |         |         |         |         |         |         |         |         |         |         |         |     |
|-----------------|-----------|--|---------|---------|---------|---------|---------|---------|---------|---------|---------|---------|---------|---------|---------|---------|-----|
| Size            | ELWT (°C) | Saturated Discharge Water Temperature (°C) |         |         |         |         |         |         |         |         |         |         |         |         |         |         |     |
|                 |           | 40   |         |         | 45      |         |         | 50      |         |         | 55      |         |         | 60      |         |         |     |
|                 |           | Cc (kW)                                    | Pi (kW) | Hc (kW) | Cc (kW) | Pi (kW) | Hc (kW) | Cc (kW) | Pi (kW) | Hc (kW) | Cc (kW) | Pi (kW) | Hc (kW) | Cc (kW) | Pi (kW) | Hc (kW) |     |
| 360             | 4         | 334  | 88.0    | 422     | 319     | 99.0    | 418     | 304     | 111     | 415     | 287     | 124     | 411     | 270     | 138     | 408     |     |
|                 | 5         | 345  | 88.2    | 433     | 330     | 99.2    | 429     | 314     | 111     | 425     | 298     | 124     | 422     | 280     | 138     | 418     |     |
|                 | 6         | 356  | 88.4    | 445     | 341     | 99.5    | 440     | 325     | 111     | 436     | 308     | 124     | 432     | 290     | 138     | 428     |     |
|                 | 7         | 368  | 88.5    | 457     | 352     | 99.7    | 452     | 336     | 112     | 448     | 319     | 125     | 443     | 301     | 139     | 439     |     |
|                 | 8         | 380  | 88.7    | 469     | 364     | 99.9    | 464     | 347     | 112     | 459     | 330     | 125     | 454     | 311     | 139     | 450     |     |
|                 | 9         | 392  | 88.8    | 481     | 375     | 100     | 476     | 358     | 112     | 471     | 341     | 125     | 466     | 322     | 139     | 461     |     |
|                 | 10        | 404  | 89.0    | 493     | 387     | 100     | 488     | 370     | 112     | 483     | 352     | 125     | 477     | 333     | 139     | 472     |     |
|                 | 11        | 417  | 89.1    | 506     | 400     | 101     | 500     | 382     | 113     | 495     | 364     | 126     | 489     | 344     | 140     | 484     |     |
|                 | 12        | 429  | 89.2    | 519     | 412     | 101     | 513     | 394     | 113     | 507     | 375     | 126     | 501     | 356     | 140     | 496     |     |
|                 | 13        | 442  | 89.4    | 532     | 425     | 101     | 526     | 406     | 113     | 520     | 387     | 126     | 514     | 367     | 140     | 508     |     |
|                 | 14        | 455  | 89.4    | 545     | 438     | 101     | 539     | 419     | 113     | 532     | 399     | 127     | 526     | 379     | 141     | 520     |     |
|                 | 15        | 469  | 89.5    | 558     | 451     | 101     | 552     | 432     | 114     | 545     | 412     | 127     | 539     | 391     | 141     | 532     |     |
|                 | 380       | 4  | 361     | 95.8    | 457     | 346     | 108     | 454     | 329     | 121     | 450     | 311     | 135     | 446     | 292     | 150     | 442 |
|                 |           | 5  | 373     | 96.0    | 469     | 357     | 108     | 465     | 340     | 121     | 461     | 322     | 135     | 457     | 303     | 150     | 453 |
|                 |           | 6  | 386     | 96.2    | 482     | 369     | 108     | 477     | 352     | 121     | 473     | 333     | 136     | 469     | 314     | 151     | 464 |
| 7               |           | 398  | 96.4    | 494     | 381     | 109     | 490     | 364     | 122     | 485     | 345     | 136     | 481     | 325     | 151     | 476     |     |
| 8               |           | 410  | 96.6    | 507     | 393     | 109     | 502     | 375     | 122     | 497     | 357     | 136     | 493     | 336     | 151     | 488     |     |
| 9               |           | 423  | 96.8    | 520     | 406     | 109     | 515     | 388     | 122     | 510     | 368     | 136     | 505     | 348     | 151     | 499     |     |
| 10              |           | 436  | 96.9    | 533     | 419     | 109     | 528     | 400     | 122     | 523     | 381     | 137     | 517     | 360     | 152     | 511     |     |
| 11              |           | 450  | 97.1    | 547     | 432     | 110     | 541     | 413     | 123     | 535     | 393     | 137     | 530     | 372     | 152     | 524     |     |
| 12              |           | 463  | 97.2    | 560     | 445     | 110     | 555     | 426     | 123     | 549     | 405     | 137     | 543     | 384     | 152     | 536     |     |
| 13              |           | 477  | 97.4    | 574     | 458     | 110     | 568     | 439     | 123     | 562     | 418     | 138     | 556     | 396     | 153     | 549     |     |
| 14              |           | 491  | 97.5    | 588     | 472     | 110     | 582     | 452     | 124     | 576     | 431     | 138     | 569     | 409     | 153     | 562     |     |
| 15              |           | 505  | 97.6    | 603     | 486     | 110     | 596     | 466     | 124     | 589     | 444     | 138     | 582     | 422     | 153     | 575     |     |
| 420             |           | 4  | 406     | 106     | 512     | 388     | 119     | 508     | 370     | 134     | 503     | 350     | 149     | 499     | 329     | 166     | 495 |
|                 |           | 5  | 420     | 106     | 526     | 401     | 120     | 521     | 382     | 134     | 516     | 362     | 150     | 512     | 341     | 166     | 507 |
|                 |           | 6  | 433     | 106     | 540     | 415     | 120     | 535     | 395     | 134     | 530     | 375     | 150     | 525     | 353     | 167     | 520 |
|                 | 7         | 447  | 107     | 554     | 428     | 120     | 548     | 409     | 135     | 543     | 388     | 150     | 538     | 366     | 167     | 532     |     |
|                 | 8         | 461  | 107     | 568     | 442     | 120     | 563     | 422     | 135     | 557     | 401     | 150     | 551     | 378     | 167     | 545     |     |
|                 | 9         | 476  | 107     | 583     | 456     | 121     | 577     | 436     | 135     | 571     | 414     | 151     | 565     | 391     | 167     | 559     |     |
|                 | 10        | 491  | 107     | 598     | 471     | 121     | 592     | 450     | 135     | 585     | 428     | 151     | 579     | 404     | 168     | 572     |     |
|                 | 11        | 506  | 107     | 613     | 485     | 121     | 606     | 464     | 136     | 600     | 442     | 151     | 593     | 418     | 168     | 586     |     |
|                 | 12        | 521  | 108     | 628     | 500     | 121     | 622     | 479     | 136     | 615     | 456     | 152     | 608     | 432     | 168     | 600     |     |
|                 | 13        | 537  | 108     | 644     | 515     | 122     | 637     | 494     | 136     | 630     | 470     | 152     | 622     | 446     | 169     | 614     |     |
|                 | 14        | 552  | 108     | 660     | 531     | 122     | 653     | 509     | 137     | 645     | 485     | 152     | 637     | 460     | 169     | 629     |     |
|                 | 15        | 568  | 108     | 676     | 547     | 122     | 669     | 524     | 137     | 661     | 500     | 153     | 652     | 474     | 170     | 644     |     |
|                 | 480       | 4  | 451     | 116     | 567     | 431     | 131     | 562     | 411     | 146     | 557     | 389     | 164     | 552     | 365     | 182     | 547 |
|                 |           | 5  | 466     | 116     | 582     | 446     | 131     | 577     | 425     | 147     | 571     | 402     | 164     | 566     | 379     | 182     | 561 |
|                 |           | 6  | 481     | 117     | 598     | 461     | 131     | 592     | 439     | 147     | 586     | 416     | 164     | 581     | 392     | 183     | 575 |
| 7               |           | 497  | 117     | 613     | 476     | 132     | 607     | 454     | 147     | 601     | 431     | 164     | 595     | 406     | 183     | 589     |     |
| 8               |           | 512  | 117     | 629     | 491     | 132     | 623     | 469     | 148     | 617     | 445     | 165     | 610     | 420     | 183     | 603     |     |
| 9               |           | 529  | 117     | 646     | 507     | 132     | 639     | 484     | 148     | 632     | 460     | 165     | 625     | 435     | 183     | 618     |     |
| 10              |           | 545  | 117     | 662     | 523     | 132     | 655     | 500     | 148     | 648     | 475     | 165     | 641     | 449     | 184     | 633     |     |
| 11              |           | 562  | 118     | 679     | 539     | 133     | 672     | 516     | 149     | 664     | 491     | 166     | 657     | 464     | 184     | 649     |     |
| 12              |           | 579  | 118     | 697     | 556     | 133     | 689     | 532     | 149     | 681     | 507     | 166     | 673     | 480     | 185     | 664     |     |
| 13              |           | 596  | 118     | 714     | 573     | 133     | 706     | 548     | 149     | 698     | 523     | 167     | 689     | 495     | 185     | 680     |     |
| 14              |           | 614  | 118     | 732     | 590     | 133     | 723     | 565     | 150     | 715     | 539     | 167     | 706     | 511     | 185     | 696     |     |
| 15              |           | 632  | 118     | 750     | 608     | 134     | 741     | 582     | 150     | 732     | 556     | 167     | 723     | 527     | 186     | 713     |     |
| 550             |           | 4  | 499     | 132     | 631     | 477     | 144     | 622     | 455     | 158     | 613     | 431     | 174     | 604     | 405     | 191     | 597 |
|                 |           | 5  | 516     | 133     | 649     | 493     | 146     | 639     | 470     | 159     | 629     | 446     | 175     | 620     | 420     | 192     | 612 |
|                 |           | 6  | 532     | 135     | 667     | 509     | 147     | 656     | 486     | 161     | 646     | 461     | 176     | 637     | 435     | 193     | 628 |
|                 | 7         | 549  | 136     | 685     | 526     | 148     | 674     | 502     | 162     | 663     | 476     | 177     | 653     | 450     | 194     | 644     |     |
|                 | 8         | 566  | 138     | 704     | 543     | 149     | 692     | 518     | 163     | 681     | 492     | 178     | 670     | 465     | 195     | 660     |     |
|                 | 9         | 584  | 139     | 723     | 560     | 151     | 711     | 535     | 164     | 699     | 508     | 179     | 688     | 481     | 196     | 677     |     |
|                 | 10        | 601  | 141     | 742     | 577     | 152     | 729     | 552     | 166     | 717     | 525     | 181     | 705     | 497     | 197     | 694     |     |
|                 | 11        | 619  | 142     | 762     | 595     | 154     | 748     | 569     | 167     | 736     | 542     | 182     | 724     | 513     | 199     | 712     |     |
|                 | 12        | 638  | 144     | 782     | 613     | 155     | 768     | 586     | 168     | 755     | 559     | 183     | 742     | 530     | 200     | 730     |     |
|                 | 13        | 657  | 146     | 802     | 631     | 157     | 788     | 604     | 170     | 774     | 576     | 185     | 761     | 547     | 201     | 748     |     |
|                 | 14        | 676  | 147     | 823     | 650     | 159     | 808     | 622     | 171     | 794     | 594     | 186     | 780     | 564     | 202     | 766     |     |
|                 | 15        | 695  | 149     | 844     | 668     | 160     | 829     | 641     | 173     | 814     | 612     | 187     | 799     | 582     | 204     | 785     |     |

**NOTES**

Cc (cooling capacity) - Pi (unit power input) - Hc (heating capacity) - ELWT (evaporator leaving water temperature - Δt 5°C)  
 Data are referred to 0.0176 m<sup>2</sup>/kW evaporator fouling factor

## 6 Dimensional drawings

### 6 - 1 Dimensional drawings

EWLD160-280G-SS

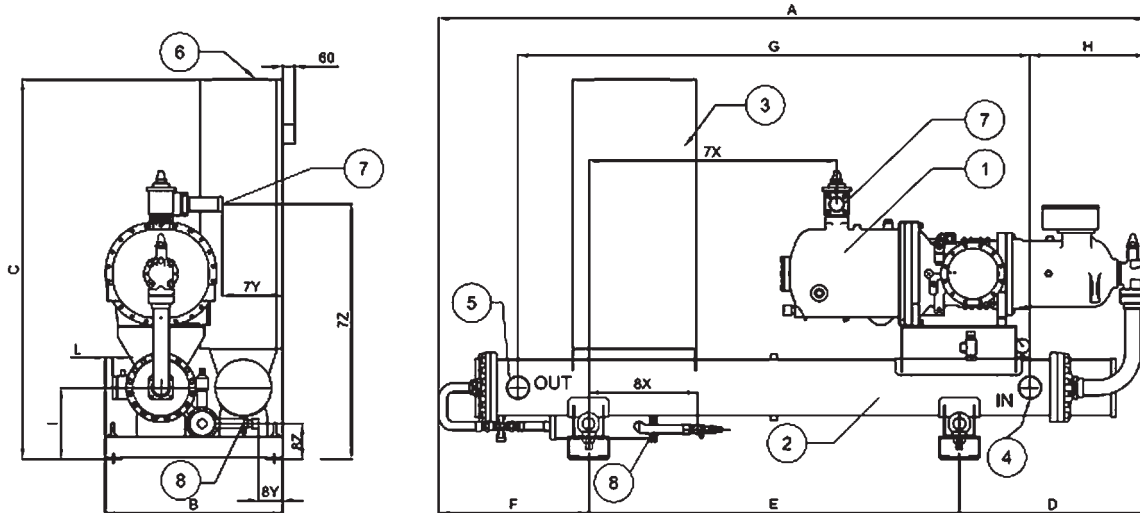

| 7x   | 7Y  | 7Z   | 8X  | 8Y  | 8Z  |
|------|-----|------|-----|-----|-----|
| 1205 | 292 | 1243 | 824 | 130 | 125 |

mm

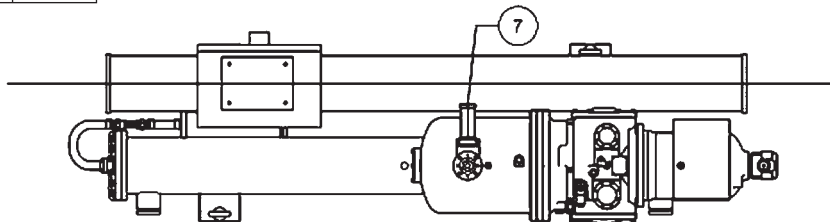

| Models      | Dimensions (mm) |     |      |     |      |     |      |     |     |    |
|-------------|-----------------|-----|------|-----|------|-----|------|-----|-----|----|
|             | A               | B   | C    | D   | E    | F   | G    | H   | I   | L  |
| EWLD-G-SS   |                 |     |      |     |      |     |      |     |     |    |
| EWLD160G-SS | 3435            | 860 | 1860 | 957 | 1800 | 943 | 2526 | 564 | 350 | 77 |
| EWLD190G-SS | 3435            | 860 | 1860 | 957 | 1800 | 943 | 2526 | 564 | 350 | 77 |
| EWLD240G-SS | 3435            | 860 | 1860 | 906 | 1800 | 755 | 2486 | 564 | 350 | 33 |
| EWLD280G-SS | 3435            | 860 | 1860 | 906 | 1800 | 755 | 2486 | 564 | 350 | 33 |

#### LEGEND

- 1 - Compressor
- 2 - Water heat exchanger evaporator
- 3 - Electrical panel
- 4 - Evaporator water inlet
- 5 - Evaporator water outlet
- 6 - Power connections slot
- 7 - Discharge line connection
- 8 - Pipe liquid connection

DMN\_1-2-3-4\_Rev.00\_1

## 6 Dimensional drawings

### 6 - 1 Dimensional drawings

EWLD320-550G-SS

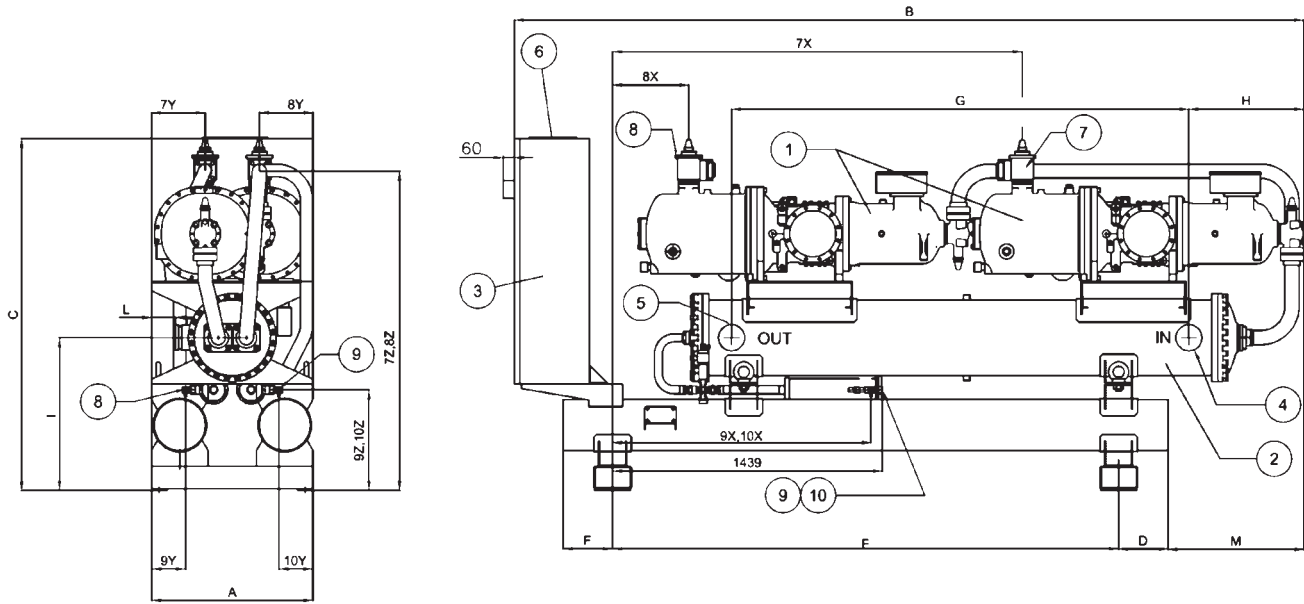

|      |     |      |     |     |      |      |     |     |      |     |     |
|------|-----|------|-----|-----|------|------|-----|-----|------|-----|-----|
| 7x   | 7Y  | 7Z   | 8X  | 8Y  | 8Z   | 9X   | 9Y  | 9Z  | 10X  | 10Y | 10Z |
| 2186 | 285 | 1706 | 406 | 285 | 1706 | 1440 | 181 | 539 | 1440 | 181 | 539 |

mm

| Models      | Dimensions (mm) |     |      |     |      |     |      |     |     |     |     |
|-------------|-----------------|-----|------|-----|------|-----|------|-----|-----|-----|-----|
|             | A               | B   | C    | D   | E    | F   | G    | H   | I   | L   | M   |
| EWLD320G-SS | 4245            | 860 | 1880 | 264 | 2700 | 264 | 2486 | 564 | 815 | 127 | 723 |
| EWLD360G-SS | 4245            | 860 | 1880 | 264 | 2700 | 264 | 2486 | 564 | 815 | 127 | 723 |
| EWLD380G-SS | 4245            | 860 | 1880 | 264 | 2700 | 264 | 2486 | 564 | 815 | 127 | 723 |
| EWLD420G-SS | 4245            | 860 | 1880 | 264 | 2700 | 264 | 2450 | 582 | 815 | 122 | 723 |
| EWLD480G-SS | 4245            | 860 | 1880 | 264 | 2700 | 264 | 2450 | 582 | 815 | 122 | 723 |
| EWLD550G-SS | 4245            | 860 | 1880 | 264 | 2700 | 264 | 2450 | 582 | 815 | 122 | 723 |

#### LEGEND

- 1 - Compressor
- 2 - Water heat exchanger evaporator
- 3 - Electrical panel
- 4 - Evaporator water inlet
- 5 - Evaporator water outlet
- 6 - Power connections slot
- 7 - Discharge line connection
- 8 - Pipe liquid connection

DMN\_1-2-3-4\_Rev.00\_2



# 6 Dimensional drawings

## 6 - 1 Dimensional drawings

**EWLD160-280G-SS**  
Partial Heat Recovery

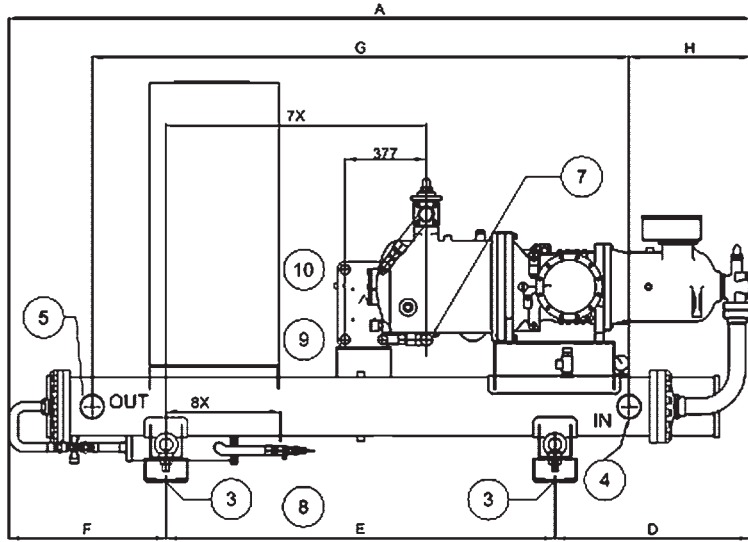
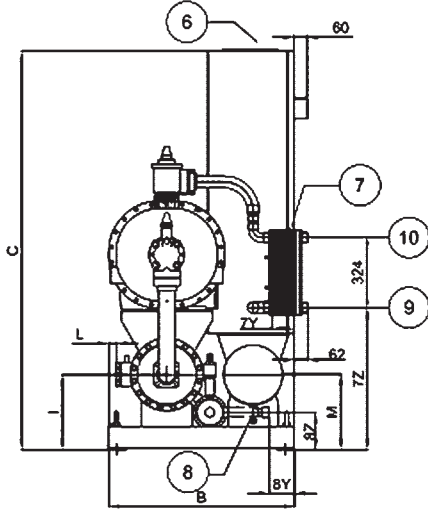

|      |     |     |     |     |     |
|------|-----|-----|-----|-----|-----|
| 7x   | 7Y  | 7Z  | 8X  | 8Y  | 8Z  |
| 1205 | 103 | 660 | 824 | 130 | 125 |

mm

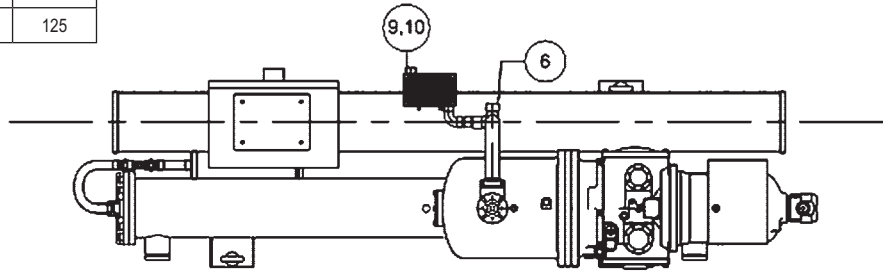

| Models      | Dimensions (mm) |     |      |     |      |     |      |     |     |    |
|-------------|-----------------|-----|------|-----|------|-----|------|-----|-----|----|
|             | A               | B   | C    | D   | E    | F   | G    | H   | I   | L  |
| EWLD-G-SS   |                 |     |      |     |      |     |      |     |     |    |
| EWLD160G-SS | 3435            | 860 | 1860 | 957 | 1800 | 943 | 2526 | 564 | 350 | 77 |
| EWLD190G-SS | 3435            | 860 | 1860 | 957 | 1800 | 943 | 2526 | 564 | 350 | 77 |
| EWLD240G-SS | 3435            | 860 | 1860 | 906 | 1800 | 755 | 2486 | 564 | 350 | 33 |
| EWLD280G-SS | 3435            | 860 | 1860 | 906 | 1800 | 755 | 2486 | 564 | 350 | 33 |

**LEGEND**

- 1 - Compressor
- 2 - Water heat exchanger evaporator
- 3 - Electrical panel
- 4 - Evaporator water inlet
- 5 - Evaporator water outlet
- 6 - Power connections slot
- 7 - Discharge line connection
- 8 - Pipe liquid connection
- 9 - Desupheater water inlet
- 10 - Desupheater water outlet

## 6 Dimensional drawings

### 6 - 1 Dimensional drawings

**EWLD320-550G-SS**  
Partial Heat Recovery

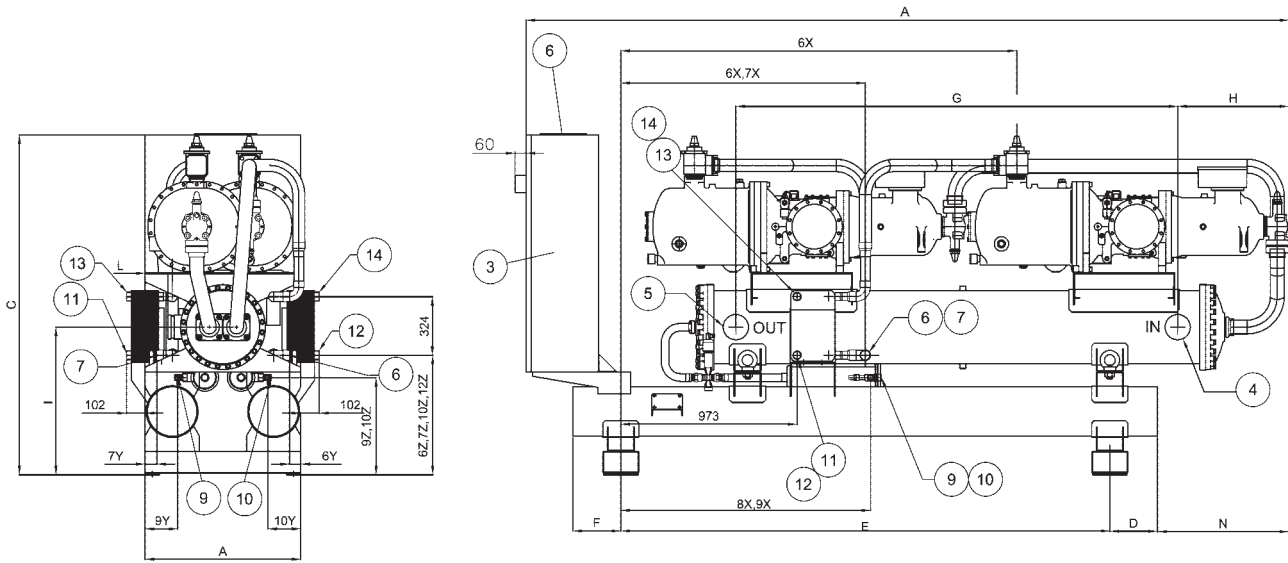

|      |    |     |      |    |     |      |     |     |      |     |     |
|------|----|-----|------|----|-----|------|-----|-----|------|-----|-----|
| 6x   | 6Y | 6Z  | 7x   | 7Y | 7Z  | 8X   | 8Y  | 8Z  | 9X   | 9Y  | 9Z  |
| 1350 | 63 | 661 | 1350 | 63 | 661 | 1379 | 181 | 539 | 1379 | 181 | 539 |

mm

| Models      | Dimensions (mm) |     |      |     |      |     |      |     |     |     |     |  |
|-------------|-----------------|-----|------|-----|------|-----|------|-----|-----|-----|-----|--|
|             | A               | B   | C    | D   | E    | F   | G    | H   | I   | L   | M   |  |
| EWLD320G-SS | 4245            | 860 | 1880 | 264 | 2700 | 264 | 2486 | 564 | 815 | 127 | 723 |  |
| EWLD360G-SS | 4245            | 860 | 1880 | 264 | 2700 | 264 | 2486 | 564 | 815 | 127 | 723 |  |
| EWLD380G-SS | 4245            | 860 | 1880 | 264 | 2700 | 264 | 2486 | 564 | 815 | 127 | 723 |  |
| EWLD420G-SS | 4245            | 860 | 1880 | 264 | 2700 | 264 | 2450 | 582 | 815 | 122 | 723 |  |
| EWLD480G-SS | 4245            | 860 | 1880 | 264 | 2700 | 264 | 2450 | 582 | 815 | 122 | 723 |  |
| EWLD550G-SS | 4245            | 860 | 1880 | 264 | 2700 | 264 | 2450 | 582 | 815 | 122 | 723 |  |

**LEGEND**

- 1 - Compressor
- 2 - Water heat exchanger evaporator
- 3 - Electrical panel
- 4 - Evaporator water inlet
- 5 - Evaporator water outlet
- 6 - Power connections slot
- 7 - Discharge line connection circ. 1
- 8 - Discharge line connection circ. 2
- 9 - Pipe liquid connection 1
- 10 - Pipe liquid connection 2
- 11 - Desuperheater water inlet circ. 1
- 12 - Desuperheater water inlet circ. 2
- 13 - Desuperheater water outlet circ. 1
- 14 - Desuperheater water outlet circ. 2

DMN\_1-2-3-4\_Rev.00\_4

## 7 Sound data

### 7 - 1 Sound level data

#### Noise Level

##### EWLD-G-SS

| EWLD-G-SS | Sound pressure level at 1 m from the unit in semispheric free field (rif. $2 \times 10^{-5}$ Pa) |        |        |        |         |         |         |         |       | Power |
|-----------|--|--------|--------|--------|---------|---------|---------|---------|-------|-------|
|           | 63 Hz  | 125 Hz | 250 Hz | 500 Hz | 1000 Hz | 2000 Hz | 4000 Hz | 8000 Hz | dB(A) | dB(A) |
| 160       | 58.0   | 58.0   | 63.5   | 68.5   | 63.0    | 64.0    | 53.0    | 49.5    | 69.7  | 87.7  |
| 190       | 58.0   | 58.0   | 63.5   | 68.5   | 63.0    | 64.0    | 53.0    | 49.5    | 69.7  | 87.7  |
| 240       | 58.0   | 58.0   | 63.5   | 68.5   | 63.0    | 64.0    | 53.0    | 49.5    | 69.7  | 87.7  |
| 280       | 58.0   | 58.0   | 63.5   | 68.5   | 63.0    | 64.0    | 53.0    | 49.5    | 69.7  | 87.7  |
| 320       | 60.0   | 60.0   | 65.5   | 70.5   | 65.0    | 66.0    | 55.0    | 51.5    | 71.7  | 90.2  |
| 360       | 60.0   | 60.0   | 65.5   | 70.5   | 65.0    | 66.0    | 55.0    | 51.5    | 71.7  | 90.2  |
| 380       | 60.0   | 60.0   | 65.5   | 70.5   | 65.0    | 66.0    | 55.0    | 51.5    | 71.7  | 90.2  |
| 420       | 60.0   | 60.0   | 65.5   | 70.5   | 65.0    | 66.0    | 55.0    | 51.5    | 71.7  | 90.2  |
| 480       | 60.0   | 60.0   | 65.5   | 70.5   | 65.0    | 66.0    | 55.0    | 51.5    | 71.7  | 90.2  |
| 550       | 60.0   | 60.0   | 65.5   | 70.5   | 65.0    | 66.0    | 55.0    | 51.5    | 71.7  | 90.2  |

#### NOTES

The values are according to ISO 3744 and are referred to: evaporator 12/7° C, 45° C saturated discharge temperature, full load operation

##### EWLD-G-SS + OPLN

| EWLD-G-SS | Sound pressure level at 1 m from the unit in semispheric free field (rif. $2 \times 10^{-5}$ Pa) |        |        |        |         |         |         |         |       | Power |
|-----------|--|--------|--------|--------|---------|---------|---------|---------|-------|-------|
|           | 63 Hz  | 125 Hz | 250 Hz | 500 Hz | 1000 Hz | 2000 Hz | 4000 Hz | 8000 Hz | dB(A) | dB(A) |
| 160       | 55.9   | 55.2   | 59.6   | 63.9   | 57.7    | 58.5    | 47.7    | 44.2    | 64.7  | 82.7  |
| 190       | 55.9   | 55.2   | 59.6   | 63.9   | 57.7    | 58.5    | 47.7    | 44.2    | 64.7  | 82.7  |
| 240       | 55.9   | 55.2   | 59.6   | 63.9   | 57.7    | 58.5    | 47.7    | 44.2    | 64.7  | 82.7  |
| 280       | 55.9   | 55.2   | 59.6   | 63.9   | 57.7    | 58.5    | 47.7    | 44.2    | 64.7  | 82.7  |
| 320       | 57.9   | 57.2   | 61.6   | 65.9   | 59.7    | 60.5    | 49.7    | 46.2    | 66.7  | 85.2  |
| 360       | 57.9   | 57.2   | 61.6   | 65.9   | 59.7    | 60.5    | 49.7    | 46.2    | 66.7  | 85.2  |
| 380       | 57.9   | 57.2   | 61.6   | 65.9   | 59.7    | 60.5    | 49.7    | 46.2    | 66.7  | 85.2  |
| 420       | 57.9   | 57.2   | 61.6   | 65.9   | 59.7    | 60.5    | 49.7    | 46.2    | 66.7  | 85.2  |
| 480       | 57.9   | 57.2   | 61.6   | 65.9   | 59.7    | 60.5    | 49.7    | 46.2    | 66.7  | 85.2  |
| 550       | 57.9   | 57.2   | 61.6   | 65.9   | 59.7    | 60.5    | 49.7    | 46.2    | 66.7  | 85.2  |

#### NOTES

The values are according to ISO 3744 and are referred to: evaporator 12/7° C, 45° C saturated discharge temperature, full load operation

## 7 Sound data

### 7 - 1 Sound level data

Sound pressure reduction values for different distances

| EWLD-G-SS | Distance |      |       |       |       |       |
|-----------|----------|------|-------|-------|-------|-------|
|           | 1m       | 5m   | 10m   | 15m   | 20m   | 25m   |
| 160       | 0.0      | -8.7 | -13.7 | -16.9 | -19.2 | -21.1 |
| 190       | 0.0      | -8.7 | -13.7 | -16.9 | -19.2 | -21.1 |
| 240       | 0.0      | -8.7 | -13.7 | -16.9 | -19.2 | -21.1 |
| 280       | 0.0      | -8.7 | -13.7 | -16.9 | -19.2 | -21.1 |
| 320       | 0.0      | -8.7 | -13.7 | -16.9 | -19.2 | -21.1 |
| 360       | 0.0      | -8.4 | -13.4 | -16.5 | -18.8 | -20.6 |
| 380       | 0.0      | -8.3 | -13.3 | -16.4 | -18.7 | -20.5 |
| 420       | 0.0      | -8.3 | -13.3 | -16.4 | -18.7 | -20.5 |
| 480       | 0.0      | -8.3 | -13.3 | -16.4 | -18.7 | -20.5 |
| 550       | 0.0      | -8.3 | -13.3 | -16.4 | -18.7 | -20.5 |

#### NOTES

The values are dB(A) (pressure level).

## 8 Installation

### 8 - 1 Installation method

#### Installation notes

##### Warning

Installation and maintenance are to be performed only by qualified personnel who are familiar with local codes and regulations, and who are experienced with this type of equipment. Must be avoided the unit installation in places that could be considered dangerous for all the maintenance operations.

##### Handling

The chiller is mounted on heavy wooden skids to protect the unit from accidental damage and to permit easy handling and moving. It is recommended that all moving and handling be performed with the skids under the unit when possible and that the skids not be removed until the unit is in the final location.

If the unit must be hoisted, it is necessary to lift the unit by attaching cables or chains at the lifting holes in the evaporator tube sheets. Spreader bars must be used to protect the control cabinet and the other areas of the chiller.

##### Location

A leveled and sufficiently strong floor is required. If necessary, additional structural members should be provided to transfer the weight of the unit to the nearest beams.

Rubber-in-shear isolators can be furnished and field placed under each corner of the package. A rubber anti-skid pad should be used under isolators if hold-down bolts are not used. Vibration isolator in all water piping connected to the chiller is recommended to avoid straining the piping and transmitting vibration and noise.

##### Minimum space requirements

Every side of the machine must be accessible for all post-installation maintenance activities. The minimum space required is shown on the following drawing.

Minimum clearance requirements for machine maintenance

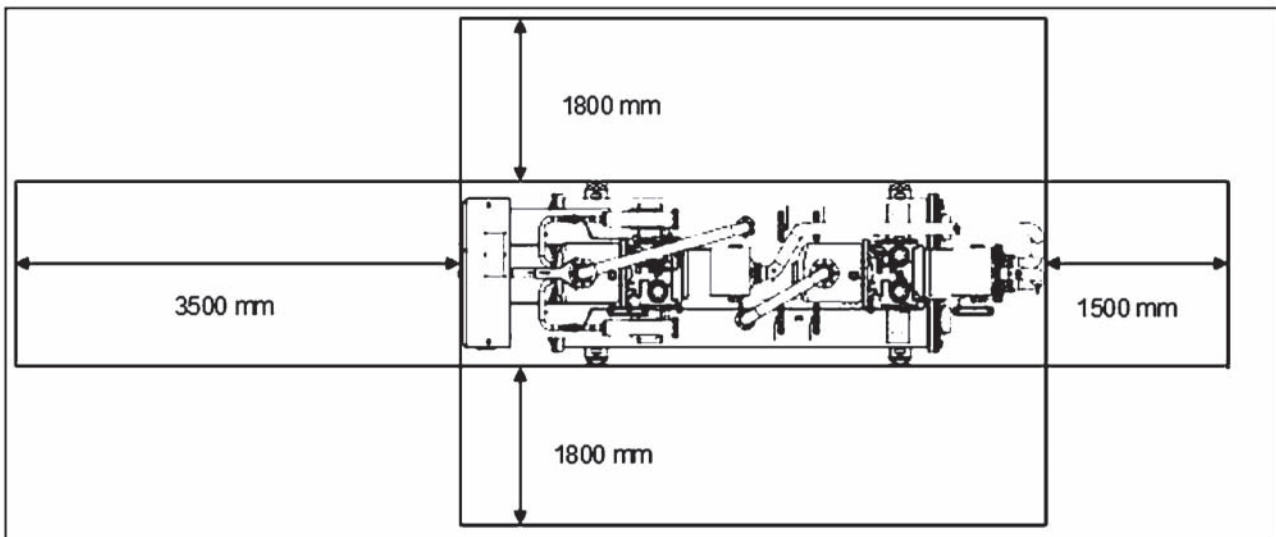



# 9 Operation range

## 9 - 1 Operation range

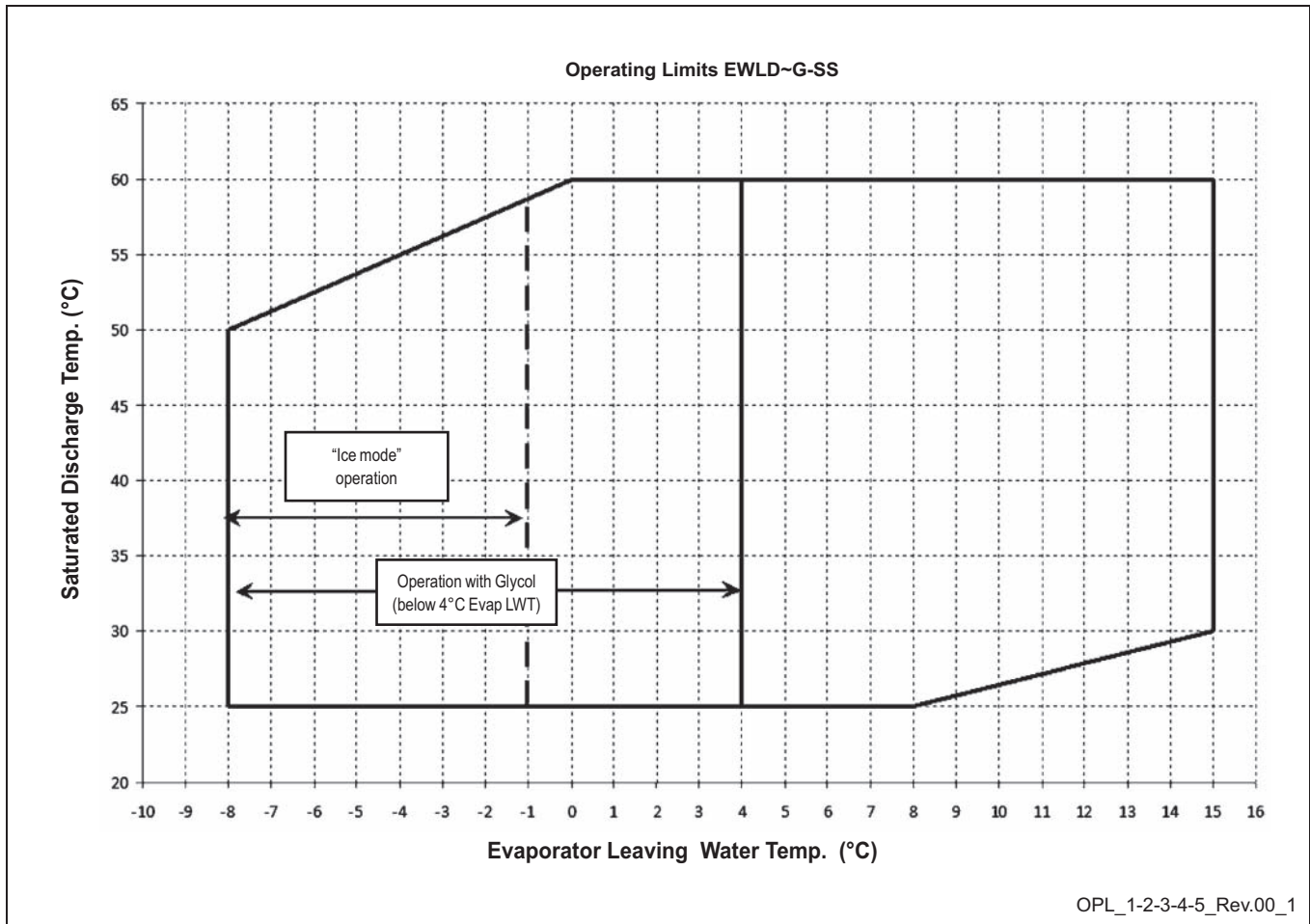

## 9 Operation range

### 9 - 1 Operation range

Table 1 - Evaporator minimum and maximum water Δt

|                         |    |   |
|-------------------------|----|---|
| Max evaporator water Δt | °C | 8 |
| Min evaporator water Δt | °C | 4 |

Table 2 - Evaporator fouling factors

| Fouling factors<br>m <sup>2</sup> °C / kW | Cooling capacity<br>correction factor | Power input<br>correction factor | EER<br>correction factor |
|---|---------------------------------------|----------------------------------|--------------------------|
| 0.0176                                    | 1.000                                 | 1.000                            | 1.000                    |
| 0.0440                                    | 0.978                                 | 0.986                            | 0.992                    |
| 0.0880                                    | 0.957                                 | 0.974                            | 0.983                    |
| 0.1320                                    | 0.938                                 | 0.962                            | 0.975                    |

Table 3.1 - Minimum glycol percentage for low water temperature

| Evaporator Leaving Water Temperature (°C) | 2  | 0  | -2 | -4 | -6 | -8 |
|---|----|----|----|----|----|----|
| Ethylene glycol (%)                       | 10 | 20 | 20 | 20 | 30 | 30 |
| Propylene glycol (%)                      | 10 | 20 | 20 | 30 | 30 | 30 |

Minimum glycol percentage to be used with evaporator leaving water temperature below 4°C to prevent freezing of water circuit.

Table 3.2 - Minimum glycol percentage for low air temperature

| Air Ambient Temperature (°C) (2) | -3  | -8  | -15 | -23 | -35 |
|----------------------------------|-----|-----|-----|-----|-----|
| Ethylene glycol (%) (1)          | 10% | 20% | 30% | 40% | 50% |
| Air Ambient Temperature (°C) (2) | -3  | -7  | -12 | -20 | -32 |
| Propylene glycol (%) (1)         | 10% | 20% | 30% | 40% | 50% |

(1) Minimum glycol percentage to prevent freezing of water circuit at indicated air ambient temperature

(2): Air ambient temperature do exceed the operating limits of the unit, as protection of water circuit may be needed in winter season at non-working conditions.

Table 4 - Correction factors for low evaporator leaving water temperature

| Evaporator Leaving Water Temperature (°C) | 2     | 0     | -2    | -4    | -6    | -8    |
|---|-------|-------|-------|-------|-------|-------|
| Cooling Capacity                          | 0.842 | 0.785 | 0.725 | 0.670 | 0.613 | 0.562 |
| Compressor Power Input                    | 0.950 | 0.940 | 0.920 | 0.890 | 0.870 | 0.840 |

Correction factors have to be applied at working conditions: evaporator leaving water temperature 7°C

Table 5 - Correction factors for water and glycol mixture

|                  | Ethylene Glycol (%)      | 10%   | 20%   | 30%   | 40%   | 50%   |
|------------------|--------------------------|-------|-------|-------|-------|-------|
| Ethylene Glycol  | Cooling Capacity         | 0.991 | 0.982 | 0.972 | 0.961 | 0.946 |
|                  | Compressor Power Input   | 0.996 | 0.992 | 0.986 | 0.976 | 0.966 |
|                  | Flow Rate (Δt)           | 1.013 | 1.04  | 1.074 | 1.121 | 1.178 |
|                  | Evaporator Pressure Drop | 1.070 | 1.129 | 1.181 | 1.263 | 1.308 |
| Propylene Glycol | Cooling Capacity         | 0.985 | 0.964 | 0.932 | 0.889 | 0.846 |
|                  | Compressor Power Input   | 0.993 | 0.983 | 0.969 | 0.948 | 0.929 |
|                  | Flow Rate (Δt)           | 1.017 | 1.032 | 1.056 | 1.092 | 1.139 |
|                  | Evaporator Pressure Drop | 1.120 | 1.272 | 1.496 | 1.792 | 2.128 |

## 9 Operation range

### 9 - 1 Operation range

#### How to use the Correction factors proposed in the previous tables

##### A) Mixture Water and Glycol --- Evaporator leaving water temperature > 4°C

- depending from the type and percentage (%) of glycol filled in the circuit (see table 3.2 and 5)
- multiply the Cooling Capacity, the Compressor Power Input by the Correction factor of Table 5
- starting from this new value of Cooling Capacity, calculate the Flow Rate (l/s) and the Evaporator Pressure Drop (kPa)
- now multiply the new Flow Rate and the new Evaporator Pressure Drop by the Correction Factors of Table 5

##### Example

Unit Size: **EWLD160G-SS**

Mixture: Water  
 Working condition: ELWT 12/7°C – Saturated Discharge Temperature 45°C  
 - Cooling capacity: 161kW  
 - Power input: 45.4kW  
 - Flow rate ( $\Delta t$  5°C): 7.69 l/s  
 - Evaporator pressure drop: 44kPa

Mixture: Water + Ethylene Glycol 30% (for a winter air temperature up to -15°C)  
 Working condition: ELWT 12/7°C – Saturated Discharge Temperature 45°C  
 - Cooling capacity:  $161 \times 0.972 = 156$  kW  
 - Power input:  $45.4 \times 0.986 = 44.8$  kW  
 - Flow rate ( $\Delta t$  5°C):  $7.45$  (referred to 156 kW)  $\times 1.074 = 8.00$  l/s  
 - Evaporator pressure drop:  $47$  (referred to 8 l/s)  $\times 1.181 = 56$ kPa

##### B) Mixture Water and Glycol --- Evaporator leaving water temperature < 4°C

- depending from the type and percentage (%) of glycol filled in the circuit (see table 3.1 and 3.2 and table 4)
- depending from the evaporator leaving water temperature (see table 4)
- multiply the Cooling Capacity, the Compressor Power Input by the Correction factor of Table 4 and Table 5
- starting from this new value of Cooling Capacity, calculate the Flow Rate (l/s) and the Evaporator Pressure Drop (kPa)
- now multiply the new Flow Rate and the new Evaporator Pressure Drop by the Correction Factors of Table 5

##### Example

Unit Size: **EWLD160G-SS**

Mixture: Water  
 Standard working condition: ELWT 12/7°C – Saturated Discharge Temperature 40°C  
 - Cooling capacity: 168 kW  
 - Power input: 40.3 kW  
 - Flow rate ( $\Delta t$  5°C): 8.02 l/s  
 - Evaporator pressure drop: 47kPa

Mixture: Water + Glycol 30% (for a low evaporator leaving temperature of -1/-6°C)  
 Working condition: ELWT -1/-6°C – Saturated Discharge Temperature 40°C  
 - Cooling capacity:  $168 \times 0.613 \times 0.972 = 100$  kW  
 - Power input:  $40.3 \times 0.870 \times 0.986 = 34.6$  kW  
 - Flow rate ( $\Delta t$  5°C):  $4.78$  l/s (referred to 100 kW)  $\times 1.074 = 5.13$  l/s  
 - Evaporator pressure drop:  $21$  kPa (referred to 5.13 l/s)  $\times 1.181 = 25$  kPa

## 9 Operation range

### 9 - 1 Operation range

#### Water charge, flow and quality

| Items <sup>(1)(5)</sup> |                         | Cooling Water                        |                             |                |                 | Cooled Water                   |                             | Heated water <sup>(2)</sup>     |                             |                                 |                             | Tendency if out of criteria |                   |
|-------------------------|-------------------------|--------------------------------------|-----------------------------|----------------|-----------------|--------------------------------|-----------------------------|---------------------------------|-----------------------------|---------------------------------|-----------------------------|-----------------------------|-------------------|
|                         |                         | Circulating System                   |                             | Once Flow      | Low temperature |                                |                             | High temperature                |                             |                                 |                             |                             |                   |
|                         |                         | Circulating water                    | Supply water <sup>(4)</sup> |                | Flowing water   | Circulating water [Below 20°C] | Supply water <sup>(4)</sup> | Circulating water [20°C ~ 60°C] | Supply water <sup>(4)</sup> | Circulating water [60°C ~ 80°C] | Supply water <sup>(4)</sup> |                             |                   |
| Items to be controlled: | pH                      | at 25°C                              | 6.5 ~ 8.2                   | 6.0 ~ 8.0      | 6.0 ~ 8.0       | 6.0 ~ 8.0                      | 6.0 ~ 8.0                   | 7.0 ~ 8.0                       | 7.0 ~ 8.0                   | 7.0 ~ 8.0                       | 7.0 ~ 8.0                   | Corrosion + Scale           |                   |
|                         | Electrical conductivity | [mS/m] at 25°C                       | Below 80                    | Below 30       | Below 40        | Below 40                       | Below 30                    | Below 30                        | Below 30                    | Below 30                        | Below 30                    | Below 30                    | Corrosion + Scale |
|                         |                         | [μS/cm] at 25°C                      | (Below 800)                 | (Below 300)    | (Below 400)     | (Below 400)                    | (Below 300)                 | (Below 300)                     | (Below 300)                 | (Below 300)                     | (Below 300)                 | (Below 300)                 | Corrosion + Scale |
|                         | Chloride ion            | [mgCl <sup>-</sup> /l]               | Below 200                   | Below 50       | Below 50        | Below 50                       | Below 50                    | Below 50                        | Below 50                    | Below 50                        | Below 30                    | Below 30                    | Corrosion         |
|                         | Sulfate ion             | [mgSO <sub>4</sub> <sup>2-</sup> /l] | Below 200                   | Below 50       | Below 50        | Below 50                       | Below 50                    | Below 50                        | Below 50                    | Below 50                        | Below 30                    | Below 30                    | Corrosion         |
|                         | M-alkalinity (pH4.8)    | [mgCaCO <sub>3</sub> /l]             | Below 100                   | Below 50       | Below 50        | Below 50                       | Below 50                    | Below 50                        | Below 50                    | Below 50                        | Below 50                    | Below 50                    | Scale             |
|                         | Total hardness          | [mgCaCO <sub>3</sub> /l]             | Below 200                   | Below 70       | Below 70        | Below 70                       | Below 70                    | Below 70                        | Below 70                    | Below 70                        | Below 70                    | Below 70                    | Scale             |
|                         | Calcium hardness        | [mgCaCO <sub>3</sub> /l]             | Below 150                   | Below 50       | Below 50        | Below 50                       | Below 50                    | Below 50                        | Below 50                    | Below 50                        | Below 50                    | Below 50                    | Scale             |
| Silica ion              | [mgSiO <sub>2</sub> /l] | Below 50                             | Below 30                    | Below 30       | Below 30        | Below 30                       | Below 30                    | Below 30                        | Below 30                    | Below 30                        | Below 30                    | Scale                       |                   |
| Items to be referred to | Iron                    | [mgFe/l]                             | Below 1.0                   | Below 0.3      | Below 1.0       | Below 1.0                      | Below 0.3                   | Below 1.0                       | Below 0.3                   | Below 1.0                       | Below 0.3                   | Below 0.3                   | Corrosion + Scale |
|                         | Copper                  | [mgCu/l]                             | Below 0.3                   | Below 0.1      | Below 1.0       | Below 1.0                      | Below 1.0                   | Below 1.0                       | Below 0.1                   | Below 1.0                       | Below 0.1                   | Below 0.1                   | Corrosion         |
|                         | Sulfite ion             | [mgS <sup>2-</sup> /l]               | Not detectable              | Not detectable | Not detectable  | Not detectable                 | Not detectable              | Not detectable                  | Not detectable              | Not detectable                  | Not detectable              | Not detectable              | Corrosion         |
|                         | Ammonium ion            | [mgNH <sub>4</sub> <sup>+</sup> /l]  | Below 1.0                   | Below 0.1      | Below 1.0       | Below 1.0                      | Below 0.1                   | Below 0.3                       | Below 0.1                   | Below 0.1                       | Below 0.1                   | Below 0.1                   | Corrosion         |
|                         | Remaining chloride      | [mgCL/l]                             | Below 0.3                   | Below 0.3      | Below 0.3       | Below 0.3                      | Below 0.3                   | Below 0.25                      | Below 0.3                   | Below 0.1                       | Below 0.3                   | Below 0.3                   | Corrosion         |
|                         | Free carbide            | [mgCO <sub>2</sub> /l]               | Below 4.0                   | Below 4.0      | Below 4.0       | Below 4.0                      | Below 4.0                   | Below 0.4                       | Below 4.0                   | Below 0.4                       | Below 4.0                   | Below 4.0                   | Corrosion         |
|                         | Stability index         |                                      | 6.0 ~ 7.0                   | ---            | ---             | ---                            | ---                         | ---                             | ---                         | ---                             | ---                         | ---                         | Corrosion + Scale |

#### NOTES

- Names, definitions and units are according to JIS K 0101. Units and figures between brackets are old units published as reference only.
- In case of using heated water (more than 40°C), corrosion is generally noticeable. Especially when the iron materials is in direct contact with water without any protection shields, it is desirable to give the valid measure for corrosion. E.g. chemical measure.
- In the cooling water using hermetic cooling tower, close circuit water is according to heated water standard, and scattered water is according to cooling water standard.
- Supply water is considered drink water, industrial water and ground water except for genuine water, neutral water and soft water.
- The above mentioned items are representable items in corrosion and scale cases.

OPL\_1-2-3-4-5\_Rev.00\_4

## 9 Operation range

### 9 - 1 Operation range

#### Water content in cooling circuits

The cooled water distribution circuits should have minimum water content to avoid excessive compressors start and stop. In fact, each time the compressor starts up, an excessive quantity of oil goes from the compressor sump and simultaneously there is a rise in the temperature of the compressor motor's stator due to the inrush current during the start-up. To prevent damage to the compressors, it has been envisaged the application of a device to limit frequent stops and restarts.

During the span of one hour there will be no more than 6 starts of the compressor. The plant side should therefore ensure that the overall water content allows a more constant functioning of the unit and consequently greater environmental comfort. The minimum water content per unit should be calculated using this simplified formula:

For 1 compressor unit

$$M \text{ (liters)} = ( 0.94 \times \Delta T(^{\circ}\text{C}) + 5.87 ) \times P(\text{kW})$$

For 2 compressors unit

$$M \text{ (liters)} = ( 0.1595 \times \Delta T(^{\circ}\text{C}) + 3.0825 ) \times P(\text{kW})$$

where:

- M minimum water content per unit expressed in litres
- P Cooling Capacity of the unit expressed in kW
- $\Delta T$  evaporator entering / leaving water temperature difference expressed in  $^{\circ}\text{C}$

This formula is valid for:

- standard microprocessor parameters

For more accurate determination of quantity of water, it is advisable to contact the designer of the plant.

# 10 Hydraulic performance

## 10 - 1 Evaporating pressure drop

### Evaporating Pressure Drops

#### EWLD-G-SS

| Size                            | 160  | 190  | 240  | 280  | 320  | 360  | 380  | 420  | 480  | 550  |
|---------------------------------|------|------|------|------|------|------|------|------|------|------|
| Cooling Capacity (kW)           | 161  | 189  | 244  | 270  | 316  | 352  | 381  | 428  | 476  | 526  |
| Water Flow (l/s)                | 7.69 | 9.03 | 11.7 | 12.9 | 15.1 | 16.8 | 18.2 | 20.4 | 22.7 | 25.1 |
| Evaporator Pressure Drops (kPa) | 44   | 60   | 41   | 49   | 57   | 56   | 64   | 50   | 51   | 61   |

Water flow and pressure drop referred to nominal condition: evaporator water in/out: 12/7°C – 45 °C saturated discharge temperature at the compressor.

EPD\_1-2\_Rev.00\_1

### Evaporating Pressure Drops

To determine the pressure drop for different versions or at different working condition, please refer to the following formula:

$$PD_2 \text{ (kPa)} = PD_1 \text{ (kPa)} \times \left( \frac{Q_2 \text{ (l/s)}}{Q_1 \text{ (l/s)}} \right)^{1.8}$$

where:

- PD<sub>2</sub> Pressure drop to be determined (kPa)
- PD<sub>1</sub> Pressure drop at nominal condition (kPa)
- Q<sub>2</sub> water flow at new working condition (l/s)
- Q<sub>1</sub> water flow at nominal condition (l/s)

#### How to use the formula: Example

The unit EWLD160G-SS has been selected for working at the following conditions:

- evaporator water in/out: 11/6°C
  - saturated discharge temperature: 50°C
- The cooling capacity at these working conditions is: 148 kW  
 The water flow at these working conditions is: 7.07 l/s

The unit EWLD160G-SS at nominal working conditions has the following data:

- evaporator water in/out: 12/7°C
  - saturated discharge temperature: 45°C
- The cooling capacity at these working conditions is: 161 kW  
 The water flow at these working conditions is: 7.69 l/s  
 The pressure drop at these working conditions is: 44 kPa

The evaporator pressure drop at the selected working condition will be:

$$PD_2 \text{ (kPa)} = 44 \text{ (kPa)} \times \left( \frac{7.07 \text{ (l/s)}}{7.69 \text{ (l/s)}} \right)^{1.8}$$

$$PD_2 \text{ (kPa)} = 38 \text{ (kPa)}$$

#### NOTE - Important

If the calculated evaporator water pressure drop is below 10 kPa or above 100 kPa please contact the factory for dedicated evaporator.

EPD\_1-2\_Rev.00\_2

# 10 Hydraulic performance

## 10 - 2 Partial heat recovery ratings

**Partial Heat Recovery Ratings**  
EWLD-G-SS

| EWLD-G-SS | Leaving desuper-heater water temp. °C | Saturated discharge temperature (°C) |         |         |         |         |
|-----------|---------------------------------------|--------------------------------------|---------|---------|---------|---------|
|           |                                       | 40                                   | 45      | 50      | 55      | 60      |
|           |                                       | Hc (kW)                              | Hc (kW) | Hc (kW) | Hc (kW) | Hc (kW) |
| 160       | 45                                    | 21.0                                 | 22.0    | 23.0    | 24.0    | 25.0    |
|           | 50                                    | 10.0                                 | 18.0    | 22.0    | 23.0    | 24.0    |
|           | 55                                    | 6.00                                 | 11.0    | 17.0    | 20.0    | 21.0    |
| 190       | 45                                    | 22.0                                 | 29.0    | 30.0    | 31.0    | 32.0    |
|           | 50                                    | 17.0                                 | 23.0    | 28.0    | 29.0    | 30.0    |
|           | 55                                    | 10.0                                 | 16.0    | 24.0    | 26.0    | 27.0    |
| 240       | 45                                    | 35.0                                 | 36.0    | 37.0    | 38.0    | 39.0    |
|           | 50                                    | 28.0                                 | 34.0    | 35.0    | 36.0    | 37.0    |
|           | 55                                    | 19.0                                 | 30.0    | 31.0    | 32.0    | 33.0    |
| 280       | 45                                    | 42.0                                 | 43.0    | 44.0    | 45.0    | 46.0    |
|           | 50                                    | 39.0                                 | 45.0    | 42.0    | 43.0    | 44.0    |
|           | 55                                    | 28.0                                 | 44.0    | 38.0    | 38.0    | 39.0    |
| 320       | 45                                    | 42.0                                 | 44.0    | 46.0    | 48.0    | 50.0    |
|           | 50                                    | 20.0                                 | 36.0    | 44.0    | 46.0    | 48.0    |
|           | 55                                    | 12.0                                 | 22.0    | 34.0    | 40.0    | 42.0    |
| 360       | 45                                    | 43.0                                 | 51.0    | 53.0    | 55.0    | 57.0    |
|           | 50                                    | 27.0                                 | 41.0    | 50.0    | 52.0    | 54.0    |
|           | 55                                    | 16.0                                 | 27.0    | 41.0    | 46.0    | 48.0    |
| 380       | 45                                    | 44.0                                 | 58.0    | 60.0    | 62.0    | 64.0    |
|           | 50                                    | 34.0                                 | 46.0    | 56.0    | 58.0    | 60.0    |
|           | 55                                    | 20.0                                 | 32.0    | 48.0    | 52.0    | 54.0    |
| 420       | 45                                    | 57.0                                 | 65.0    | 67.0    | 69.0    | 71.0    |
|           | 50                                    | 45.0                                 | 57.0    | 63.0    | 65.0    | 67.0    |
|           | 55                                    | 29.0                                 | 46.0    | 55.0    | 58.0    | 60.0    |
| 480       | 45                                    | 70.0                                 | 72.0    | 74.0    | 76.0    | 78.0    |
|           | 50                                    | 56.0                                 | 68.0    | 70.0    | 72.0    | 74.0    |
|           | 55                                    | 38.0                                 | 60.0    | 62.0    | 64.0    | 66.0    |
| 550       | 45                                    | 96.0                                 | 86.0    | 88.0    | 90.0    | 92.0    |
|           | 50                                    | 78.0                                 | 90.0    | 84.0    | 86.0    | 88.0    |
|           | 55                                    | 56.0                                 | 88.0    | 76.0    | 76.0    | 78.0    |

**NOTES**

Leaving Evaporator Water Temperature 7°C, ΔT 5°C;  
Hc (heating heat recovery capacity)



# 10 Hydraulic performance

## 10 - 3 Partial heat recovery pressure drop

### Partial Heat Recovery pressure drops

EWLD-G-SS

| Size EWLD~G-SS                     | 160  | 190  | 240 | 280 | 320 | 360 | 380 | 420 | 480 | 550 |
|------------------------------------|------|------|-----|-----|-----|-----|-----|-----|-----|-----|
| Heating Capacity (kW)              | 22   | 29   | 36  | 43  | 44  | 51  | 58  | 65  | 72  | 86  |
| Water Flow (l/s)                   | 1.05 | 1.39 | 1.7 | 2.1 | 2.1 | 2.4 | 2.8 | 3.1 | 3.4 | 4.1 |
| Heat Recovery Pressure Drops (kPa) | 2    | 2    | 2   | 3   | 2   | 1   | 1   | 1   | 2   | 3   |

#### NOTES

Water flow and pressure drop referred to nominal condition: evaporator water in/out: 12/7°C – saturated discharge temperature 45°C – water heat recovery in/out 40/45°C

OPT\_1-2-3\_Rev.00\_2

### Partial Heat Recovery Pressure Drops

To determinate the pressure drop for different versions or at different working condition, please refer to the following formula:

$$PD_2 \text{ (kPa)} = PD_1 \text{ (kPa)} \times \left( \frac{Q_2 \text{ (l/s)}}{Q_1 \text{ (l/s)}} \right)^{1.80}$$

where:

- PD<sub>2</sub> Pressure drop to be determinate (kPa)
- PD<sub>1</sub> Pressure drop at nominal condition (kPa)
- Q<sub>2</sub> water flow at new working condition (l/s)
- Q<sub>1</sub> water flow at nominal condition (l/s)

#### How to use the formula: Example

The unit EWLD160G-SS has been selected for working at the following conditions:

- evaporator water in/out: 12/7°C
  - saturated discharge temperature: 40°C
  - Partial heat recovery leaving water temperature 45/50°C
- The heating capacity at these working conditions is: 10 kW  
The water flow at these working conditions is: 0.48 l/s

The unit EWLD160G-SS at nominal working conditions has the following data:

- evaporator water in/out: 12/7°C
  - saturated discharge temperature: 45°C
  - Partial heat recovery leaving water temperature 40/45°C
- The heating capacity at these working conditions is: 22 kW  
The water flow at these working conditions is: 1.05 l/s  
The pressure drop at these working conditions is: 2 kPa

The pressure drop at the selected working condition will be:

$$PD_2 \text{ (kPa)} = 2 \text{ (kPa)} \times \left( \frac{0.48 \text{ (l/s)}}{1.0 \text{ (l/s)}} \right)^{1.80}$$

$$PD_2 \text{ (kPa)} = 1 \text{ (kPa)}$$

OPT\_1-2-3\_Rev.00\_3

# 11 Specification text

## 11 - 1 Specification text

### Technical Specification for Water Cooled Screw Chiller

#### GENERAL

The water cooled screw chiller will be designed and manufactured in accordance with following European directives:

|                                 |                            |
|---------------------------------|----------------------------|
| Construction of pressure vessel | 97/23/EC (PED)             |
| Machinery Directive             | 2006/42/EC                 |
| Low Voltage                     | 2006/95/EC                 |
| Electromagnetic Compatibility   | 2004/108/EC                |
| Electrical & Safety codes       | EN 60204-1 / EN 60335-2-40 |
| Manufacturing Quality Stds      | UNI – EN ISO 9001:2004     |

The unit will be tested at full load in the factory at the nominal working conditions and water temperatures. Before shipment a full test will be held to avoid any losses.

Chiller will be delivered to the job site completely assembled and charged with right refrigerant and oil quantity. Comply with the manufacturer instructions for rigging and handling equipment.

The unit will be able to start up and operate as standard at full load and condenser entering fluid temperature from .... °C to .... °C with an evaporator leaving fluid temperature between .... °C and .... °C.

All units published performances have to be certified by **Eurovent**.

#### REFRIGERANT

Only R-134a will be accepted.

#### PERFORMANCE

- ✓ Number of water cooled screw chiller: .....
- ✓ Cooling capacity for single water cooled screw chiller: ..... kW
- ✓ Power input for single water cooled screw chiller in cooling mode: ..... kW
- ✓ Shell & tube evaporator entering water temperature in cooling mode: ..... °C
- ✓ Shell & tube evaporator leaving water temperature in cooling mode: ..... °C
- ✓ Shell & tube evaporator water flow: ..... l/s
- ✓ Saturated Discharge Temperature: ..... °C
- ✓ The unit should work with electricity in range 400V ±10%, 3ph, 50Hz without neutral and shall only have one power connection point.

#### UNIT DESCRIPTION

Chiller shall include as standard: 1, 2 independent refrigerant circuits, semi-hermetic rotary single screw compressors, electronic expansion device (EEXV), refrigerant direct expansion shell & tube heat exchangers, R134a refrigerant, lubrication system, motor starting components, control system and all components necessary for safe and stable unit operation. Chiller will be factory assembled on a robust base-frame made of zinc coated steel, protected by an epoxy paint.

#### NOISE LEVEL AND VIBRATIONS

Sound pressure level at 1 meter distance in free field, semispheric conditions, shall not exceed .....dB(A). The sound pressure levels must be rated in accordance to ISO 3744.

Other types of rating unacceptable. Vibration level should not exceed 2 mm/s.

#### DIMENSIONS

Unit dimensions shall not exceed following indications:

- ✓ unit length ..... mm,
- ✓ unit width ..... mm,
- ✓ unit height ..... mm.

# 11 Specification text

## 11 - 1 Specification text

### CHILLER COMPONENTS

#### Compressors

- ✓ Semi-hermetic, single-screw type with one main helical rotor meshing with gaterotor. The gaterotor will be constructed of a carbon impregnated engineered composite material. The gaterotor supports will be constructed of cast iron.
- ✓ The oil injection shall be used in order to get high EER (Energy Efficiency Ratio) also at high condensing pressure and low sound pressure levels in each load condition.
- ✓ Refrigerant system differential pressure shall provide oil flow throught service replaceble, 0.5 micron, full flow, cartridge type oil filter internal to compressor.
- ✓ Refrigerant system differential pressure shall provide oil injection on all moving compressor parts to correctly lubricate them. Electrical oil pump lubricating system is not acceptable.
- ✓ The compressor's oil cooling must be realized, when necessary, by refrigerant liquid injection. External dedicated heat exchanger and additional piping to carry the oil from the compressor to heat exchanger and viceversa will be not accepted.
- ✓ The compressor shall be provided with an external, high efficiency, cyclonic type oil separator and with built-in oil filter, cartridge type.
- ✓ The compressor shall be direct electrical driven, without gear transmission between the screw and the electrical motor.
- ✓ Shall be present two thermal protection realized by a thermistor for high temperature protection: one temperature sensor to protect electrical motor and another sensor to protect unit and lubricating oil from high discharge gas temperature.
- ✓ Compressor shall be fully field serviceable. Compressor that must be removed and returned to the factory for service shall be unacceptable.

#### Cooling capacity control system

- ✓ Each unit will have a microprocessor for the control of compressor slide valve's position and the instantaneous RPM value of the motor.
- ✓ The unit capacity control shall be infinitely modulating, from 100% down to 25% for each circuit (from 100% down to 12,5% of full load for unit with 2 compressors). The chiller shall be capable of stable operation to a minimum of 12,5% of full load without hot gas bypass.
- ✓ Step unloading unacceptable because of evaporator leaving water temperature fluctuation and low unit efficiency at partial load.
- ✓ The system shall stage the unit based on the leaving evaporator water temperature that shall be controlled by a PID (Proportional Integral Derivative) loop.
- ✓ Unit control logic shall to manage frequency level of the compressor electric motor to exactly match plant load request in order to keep constant the set point for delivered chilled water temperature. In this operating condition unit control logic shall modulate electrical frequency level in a range lower and upper the nominal electrical network value fixed at 50 Hz.
- ✓ The microprocessor unit control shall detect conditions that approach protective limits and take self-corrective action prior to an alarm occurring. The system shall automatically reduce chiller capacity when any of the following parameters are outside their normal operating range:
  - o High condenser pressure
  - o Low evaporation refrigerant temperature
  - o High compressor motor amps

#### Evaporator

- ✓ The units shall be supplied with shell and tubes counter-flow heat exchanger with single refrigerant pass. It will be refrigerant direct expansion type with refrigerant inside the tubes and water outside (shell side). It will include carbon steel tube sheets, with straight copper tubes internally wound for higher efficiencies, expanded on the tube plates.
- ✓ The evaporator will have 2 circuits, one for each compressor and shall be single refrigerant pass.
- ✓ The water connections shall be VICTAULIC type connections as standard to ensure quick mechanical disconnection between the unit and the hydronic network.
- ✓ Evaporator is manufactured in accordance to PED approval.

# 11 Specification text

## 11 - 1 Specification text

### Refrigerant circuit

Each circuit shall include as standard: electronic expansion device piloted by unit's microprocessor control, suction line shut-off valve, replaceable core filter-drier, sight glass with moisture indicator and insulated suction line.

### Control panel

- ✓ Field power connection, control interlock terminals, and unit control system should be centrally located in an electric panel (IP 54). Power and starting controls should be separate from safety and operating controls in different compartments of the same panel.
- ✓ Starting shall be Wye-Delta type as standard.
- ✓ Operating and safety controls should include energy saving control; emergency stop switch; overload protection for compressor motor; high and low pressure cut-out switch (for each refrigerant circuit); anti-freeze thermostat; cut-out switch for each compressor.
- ✓ All of the information regarding the unit will be reported on a display and with the internal built-in calendar and clock that will switch the unit ON/OFF during day time all year long.
- ✓ The following features and functions shall be included:
  - resetting chilled water temperature by controlling the return water temperature or by a remote 4-20 mA DC signal or by controlling the external ambient temperature;
  - soft load function to prevent the system from operating at full load during the chilled fluid pulldown period;
  - password protection of critical parameters of control;
  - start-to-start and stop-to-start timers to provide minimum compressor off-time with maximum motor protection;
  - communication capability with a PC or remote monitoring;
  - discharge pressure control through intelligent cycling of condenser fans;
  - lead-lag selection by manual or automatically by circuit run hours;
  - double set point for brine unit version;
  - scheduling via internal time clock to allow programming of a yearly start-stop schedule accommodating weekends and holidays.

### Optional High Level Communications Interface

The controller as a minimum shall be capable of providing the data shown in the above list, using the following options:

- RS485 Serial card
- RS232 Serial card
- LonWorks interface to FTT10A Transceiver.
- Bacnet Compatible
- Use of Compass Points (manufactured by North Communications) to allow communications with such as Honeywell, Satchwell, Johnson Controls, Trend etc.



Daikin's unique position as a manufacturer of air conditioning equipment, compressors and refrigerants has led to its close involvement in environmental issues. For several years Daikin has had the intention to become a leader in the provision of products that have limited impact on the environment. This challenge demands the eco design and development of a wide range of products and an energy management system, resulting in energy conservation and a reduction of waste.



The present leaflet is drawn up by way of information only and does not constitute an offer binding upon Daikin Europe N.V.. Daikin Europe N.V. has compiled the content of this leaflet to the best of its knowledge. No express or implied warranty is given for the completeness, accuracy, reliability or fitness for particular purpose of its content and the products and services presented therein. Specifications are subject to change without prior notice. Daikin Europe N.V. explicitly rejects any liability for any direct or indirect damage, in the broadest sense, arising from or related to the use and/or interpretation of this leaflet. All content is copyrighted by Daikin Europe N.V.



Daikin Europe N.V. participates in the Eurovent Certification Programme for Air Conditioners (AC), Liquid Chilling Packages (LCP) and Fan Coil Units (FC); the certified data of certified models are listed in the Eurovent Directory. Multi units are Eurovent certified for combinations up to 2 indoor units.

Daikin products are distributed by: