



Chillers

# Technical Data

**R-134a**

Air Cooled Single Circuit Condensing Unit



ECDEN10-410

ERAD-E-  
120-490 kW

# TABLE OF CONTENTS

## ERAD~E-

1	Features and advantages .....	2
2	General characteristics .....	4
3	Nomenclature .....	9
4	Technical specifications .....	10
5	Sound Levels .....	14
6	Operating limits .....	16
7	Standard rating .....	17
	Cooling capacity tables .....	17
8	Options .....	21
9	Dimensions .....	24
10	Installation notes .....	26
11	Specification .....	30

# 1 Features and advantages

## **Low operating cost**

ERAD~E- is the result of careful design, aimed to optimize the energy efficiency of the condensing units, with the objective of bringing down operating costs and improving installation profitability, effectiveness and economical management.

The ERAD~E- condensing units use the new very high efficiency single rotor screw compressor design, large condenser coil surface area for maximum heat transfer and low discharge pressure, and advanced technology condenser fans.

## **Low operating sound levels**

Very low sound levels both at full load and part load conditions are achieved by the latest compressor design and by a unique new fan that moves large volume of air at exceptionally low sound levels and by the virtually vibration-free operation.

## **Excellent serviceability**

Field serviceability has not been sacrificed to meet design performance objectives. The compressor is equipped with discharge, liquid and suction shut off valves. The compressor and serviceable components such as filter driers are located on the outside edges of the base allowing easy access. The shaped of the coil allows easy access for inspection and service. The MicroTech III controller gives detailed information on the causes of an alarm or fault.

## **Proven reliability**

Extensive quality control checks during testing and prior shipment guarantee the delivery of a state of the art product.

## **Infinite capacity control**

Cooling capacity control is infinitely variable by means of a single screw compressor controlled by microprocessor system. Each unit has infinitely variable capacity control from 100% down to 25%. This modulation allows the compressor capacity to exactly match the required cooling load.

In case a compressor with load step control is used, the compressor capacity, at partial loads, will be too high or too low compared to the building cooling load. The result is an increase in unit energy costs, particularly at the part load conditions at which the unit operates most of the time.

The ERAD~E- condensing units with stepless regulation offer benefits that the units with step regulation are unable to match. Only a condensing unit with stepless regulation is able to follow the system's cooling demand at any time and to deliver chilled liquid or air at setpoint.

# 1 Features and advantages

## Superior control logic

The new MicroTech III controller provides an easy to use control. The control logic is designed to guarantee a stable operation, to provide maximum efficiency, to continue operation in unusual operating conditions and to provide a history of unit operation. One of the greatest benefits is the easy interface with LonWorks, Bacnet, Ethernet TCP/IP or Modbus communications.

## Code requirements – Safety and observant of laws/directives

All ERAD-E- units are designed and manufactured in accordance with applicable selections of the following:

Construction of pressure vessel	97/23/EC (PED)
Machinery Directive	2006/42/EC
Low Voltage	2006/95/EC
Electromagnetic Compatibility	2004/108/EC
Electrical & Safety codes	EN 60204-1 / EN 60335-2-40
Manufacturing Quality Stds	UNI – EN ISO 9001:2004

## Certifications

All units manufactured by Daikin are CE marked, complying with European directives in force, concerning manufacturing and safety. On request units can be produced complying with laws in force in non-European countries (ASME, GOST, etc.), and with other applications, such as naval (RINA, etc.).

## Versions

ERAD-E- is available in a Standard Efficiency version:

**S:** Standard Efficiency

10 sizes to cover a range from 116 up to 488 kW with an EER up to 3.30 (data referred to Standard Sound configuration)

The EER (Energy Efficiency Ratio) is the ratio of the Cooling Capacity to the Power Input of the unit. The Power Input includes: the power input for operation of the compressor and fans, the power input of all control and safety devices.

## Sound configurations

ERAD-E- is available in two different sound level configurations:

**S:** Standard Sound

Condenser fan rotating at 920 rpm, rubber antivibration under compressor

**L:** Low Sound

Condenser fan rotating at 715 rpm, rubber antivibration under compressor, compressor sound enclosure

## 2 General characteristics

### Cabinet and structure

The cabinet is made of galvanized steel sheet and painted to provide a high resistance to corrosion. Colour Ivory White (Munsell code 5Y7.5/1) (±RAL7044). The base frame has eye-hook for lifting the unit with ropes for an easy installation. The weight is uniformly distributed along the profiles of the base and this facilitates the arrangement of the unit.

### Screw compressors with integrated oil separator

From size ERAD120E-SS to size ERAD250E-SS and from size ERAD120E-SL to size ERAD240E-SL

The compressor is semi-hermetic, single-screw type with one gate-rotor (made of carbon impregnated engineered composite material). The compressor has one slide managed by the unit microprocessor for infinitely modulating the capacity between 100% to 25%. An integrated high efficiency oil separator maximises the oil separation. Standard Start is Wye-delta (Y-Δ) type.

From size ERAD310E-SS to size ERAD490E-SS and from size ERAD300E-SL to size ERAD460E-SL

The compressor is semi-hermetic, single-screw type with gate-rotor (with the latest high-strength fibre reinforced star material). The compressor has an asymmetric slide regulation managed by the unit controller for infinitely modulating capacity between 100% to 25%. An integrated high efficiency oil separator maximizes the oil separation. Standard Start is Wye-delta (Y-Δ) type.

### Ecological R-134a refrigerant

The compressors have been designed to operate with R-134a, ecological refrigerant with very low ODP (Ozone Depletion Potential) and GWP (Global Warming Potential) that means low TEWI (Total Equivalent Warming Impact).

### Condenser coils

The condenser is manufactured with internally enhanced seamless copper tubes arranged in a staggered row pattern and mechanically expanded into lanced and rippled aluminium condenser fins with full fin collars. An integral sub-cooler circuit provides sub-cooling to effectively eliminate liquid flashing and increase the cooling capacity without increasing the power input.

### Condenser fans

The condenser fans are propeller type with high efficiency design blades to maximize performances. The material of the blades is glass reinforced resin and each fan is protected by a guard. Fan motors are protected by circuit breakers installed inside the electrical panel as a standard. The motors are IP54.

### Refrigerant circuit

Each unit has 1 refrigerant circuit and includes:

- Compressor with integrated oil separator
- Air Cooled Condenser
- Discharge line shut off valve
- Liquid line shut off valve
- Suction line shut off valve
- Sight glass with moisture indicator
- Filter drier
- Charging valves
- High pressure switch
- High and low pressure transducers

### Electrical control panel

Power and control are located in the main panel that is manufactured to ensure protection against all weather conditions. The electrical panel is IP54 and (when opening the doors) internally protected with plexiglas panel against possible accidental contact with electrical components (IP20). The main panel is fitted with a main switch interlocked door.

## 2 General characteristics

### **Power Section**

The power section includes compressors fuses, fan circuit breaker, fan contactors and control circuit transformer.

### **MicroTech III controller**

MicroTech III controller is installed as standard; it can be used to modify unit set-points and check control parameters. A built-in display shows condensing unit operating status plus temperatures and pressures of liquid or air, refrigerant and air, programmable values, set-points. A sophisticated software with predictive logic, selects the most energy efficient combination of compressor, condenser fans to keep stable operating conditions to maximise condensing unit energy efficiency and reliability. MicroTech III is able to protect critical components based on external signs from its system (such as motor temperatures, refrigerant gas and oil pressures, correct phase sequence, pressure switches and evaporator). The input coming from the high pressure switch cuts all digital output from the controller in less than 50ms, this is an additional security for the equipment. Fast program cycle (200ms) for a precise monitoring of the system. Floating point calculations supported for increased accuracy in P/T conversions.

### **Control section - main features**

- Management of the compressor stepless capacity and fans modulation.
- Condensing unit enabled to work in partial failure condition.
- Full routine operation at condition of:
  - high ambient temperature value
  - high thermal load
  - high evaporator entering liquid or air temperature (start-up)
- Display of liquid or air entering/leaving temperature.
- Display of Outdoor Ambient Temperature.
- Display of condensing-evaporating temperature and pressure, suction and discharge superheat for the circuit.
- Leaving liquid or air evaporator temperature regulation. Temperature tolerance = 0,1°C.
- Compressor hours counter.
- Display of Status Safety Devices.
- Number of starts and compressor working hours.
- Optimized management of compressor load.
- Fan management according to condensing pressure.
- Re-start in case of power failure (automatic / manual).
- Soft Load (optimized management of the compressors load during the start-up).
- Start at high evaporator liquid or air temperature.
- Return Reset (Set Point Reset based on return of liquid or air temperature of evaporating section).
- OAT (Outside Ambient temperature) Reset.
- Set point Reset (optional).
- Application and system upgrade with commercial SD cards.
- Ethernet port for remote or local servicing using standard web browsers.
- Two different sets of default parameters could be stored for easy restore.

## 2 General characteristics

### Safety device / logic for each refrigerant circuit

- High pressure (pressure switch).
- High pressure (transducer).
- Low pressure (transducer).
- Fans circuit breaker.
- High compressor discharge temperature.
- High motor winding temperature.
- Phase Monitor.
- Low pressure ratio.
- High oil pressure drop.
- Low oil pressure.
- No pressure change at start.

### System security

- Phase monitor.
- Low Ambient temperature lock-out.
- Freeze protection.

### Regulation type

Proportional + integral + derivative regulation on the leaving water evaporator output probe.

### Condensing pressure

Condensing pressure can be controlled in according to the entering air temperature to the condenser coil. The fans can be managed either with steps, or with a 0/10 V modulating signal or with a mixed 0/10V + Steps strategy to cover all possible operational conditions.

### MicroTech III

MicroTech III built-in terminal has the following features.

- 164x44 dots liquid crystal display with white back lighting. Supports Unicode fonts for multi-lingual.
- Key-pad consisting of 3 keys.
- Push'n'Roll control for an increased usability.
- Memory to protect the data.
- General faults alarm relays.
- Password access to modify the setting.
- Application security to prevent application tampering or hardware usability with third party applications.
- Service report displaying all running hours and general conditions.
- Alarm history memory to allow an easy fault analysis.

### Supervising systems (on request)

#### MicroTech III remote control

MicroTech III is able to communicate to BMS (Building Management System) based on the most common protocols as:

- ModbusRTU
- LonWorks, now also based on the international 8040 Standard Chiller Profile and LonMark Technology
- BacNet BTP certified over IP and MS/TP (class 4) (Native)
- Ethernet TCP/IP.

## 2 General characteristics

### Standard accessories (supplied on basic unit)

**Wye-Delta Compressors starter (Y-Δ)** – For low inrush current and reduced starting torque.

**Double set-point** – Dual leaving liquid or air temperature set-points.

**Fans circuit breakers thermal overload relays** – Safety devices against fan motor overloading in addition to the normal protection envisaged by the electrical windings.

**Phase monitor** – The phase monitor controls that phases sequence is correct and controls phase loss.

**Discharge line shut off valves** – Installed on the discharge port of the compressor to facilitate maintenance operation.

**Suction line shut off valve** – Installed on the suction port of the compressor to facilitate maintenance operation.

**Ambient outside temperature sensor and set-point reset**

**Hour run meter**

**General fault contactor** – Alarm relay.

**Set-point reset** – The leaving liquid or air temperature set-point can be overwritten with the following options: 4-20mA from external source (by user); outside ambient temperature; evaporator liquid or air temperature  $\Delta t$ .

**Demand limit** – User can limit the load of the unit by 4-20mA signal or by network system

**Alarm from external device** – Microprocessor is able to receive an alarm signal from an external device (pump etc...). User can decide if this alarm signal will stop or not the unit.

**Fans circuit breakers** – Safety device against motor overloading and short circuit

**Main switch interlock door**



## 2 General characteristics

### Options (on request)

**Total heat recovery** – Provided with plate to plate heat exchangers to produce hot water.

**Partial heat recovery** – Plate to plate heat exchangers installed between the compressor discharge and the condenser coil, allowing to produce hot water.

**Soft starter** – Electronic starting device to reduce the mechanical stress during compressor start-up.

**Compressor thermal overload relays** – Safety devices against compressor motor overloading. This device together with internal motor protection (standard) guarantee the best safety system for compressor motor.

**Under/Over Voltage** – This device control the voltage value of power supply and stop the chiller if the value exceeds the allowed operating limits.

**Energy Meter** – This device allows to measure the energy absorbed by the condensing unit during its life. It is installed inside the control box mounted on a DIN rail and show on a digital display: Line-to-Line Voltage, Phase and Average Current, Active and Reactive Power, Active Energy, Frequency.

**Capacitors for power factor correction** – To increase the operating power factor of the unit at nominal operating conditions. The capacitors are “dry” self-regenerating type with over pressure disconnecting safety device insulated with a no toxic dielectric mix with no PCB or PCT.

**Current limit** – To limit maximum absorbed current of the unit whenever is required

**Fan speed regulation** – To control the fan speed revolution for smooth operating control of the unit during low ambient temperature operation. This option improves also the sound level of the unit.

With “Fan speed regulation” option, by different microprocessor setting, it is also possible to set the “Fan Silent Mode” configuration. It means that the microprocessor clock switches the fan at low speed according to the client setting (i.e. Night & Day), providing that the ambient temperature/condensing pressure is allowing the speed change.

It allows a perfect condensing control down to  $-10^{\circ}\text{C}$ .

**Speedtrol** – Continuous fan speed modulation on the first fan of the circuit. It allows the unit working with air temperature down to  $-18^{\circ}\text{C}$ .

### Condenser coil guards

**Cu-Cu condensing coils** – To give better protection against corrosion in aggressive environments.

**Cu-Cu-Sn condensing coils** – To give better protection against corrosion in aggressive and in salty air environments.

**Alucoat condensing coils** – Fins are protected by a special acrylic paint with a high resistance to corrosion.

### High pressure side manameter

### Kit container

**Rubber type anti vibration mounts** – Supplied separately, these are positioned under the base of the unit during installation to reduce vibrations.

**Spring type anti vibration mounts** – Supplied separately, these are positioned under the base of the unit during installation. Ideal for dampening vibrations for installation on roofs and metallic structures.

### Double pressure relief valve with diverter

### Compressors circuit breakers

### 3 Nomenclature

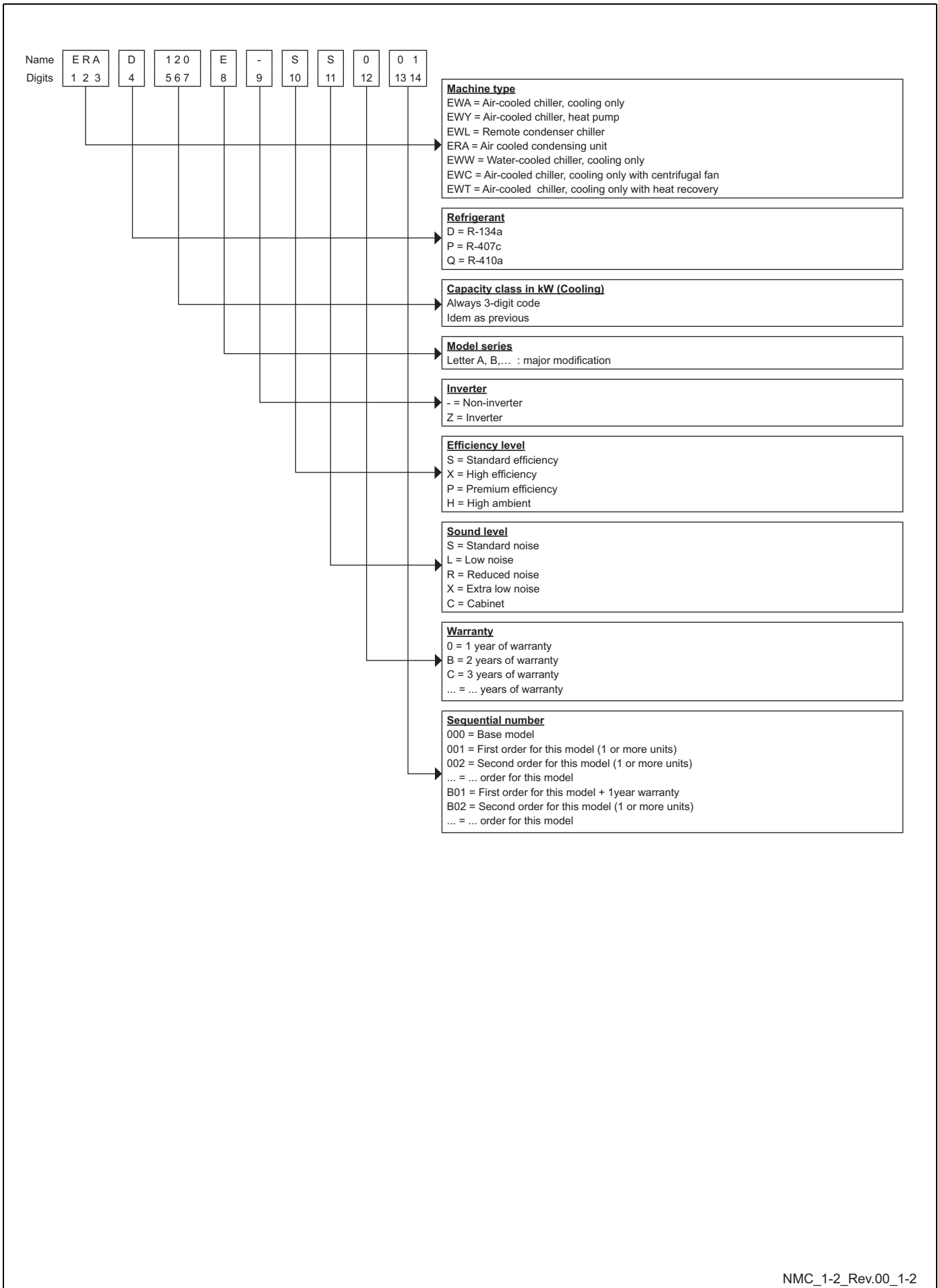

## 4 Technical specifications

4-1 Technical Specifications			ERAD-E-SS	120	140	170	200	220	250	310	370	440	490	
Capacity (1)	Cooling	kW		121	144	165	196	219	252	306	370	435	488	
Capacity control	Type	---	Stepless											
	Minimum capacity	%	25											
Unit power input (1)	Cooling	kW	41.8	51.0	57.4	65.2	73.7	76.6	92.8	122.0	147.2	160.8		
EER (1)		---	2.90	2.83	2.87	3.00	2.97	3.28	3.30	3.04	2.96	3.03		
Casing	Colour	---	Ivory White											
	Material	---	Galvanized and painted steel sheet											
Dimensions	Unit	Height	mm	2,273						2,223				
		Width	mm	1,292						2,236				
		Length	mm	2,165			3,065			3,070				
Weight	Unit	kg	1,564	1,587	1,698	1,739	1,886	1,928	2,355	2,559	2,642	2,677		
	Operating Weight	kg	1,594	1,620	1,733	1,779	1,928	1,973	2,416	2,623	2,715	2,754		
Air heat exchanger	Type	---	High efficiency fin and tube type with integral subcooler											
Fan	Type	---	Direct propeller type											
	Drive	---	DOL											
	Diameter	mm	800											
	Nominal air flow	l/s	10,922	10,575	16,383	15,863	21,844	21,150	32,767	32,767	31,725	31,725		
	Model	Quantity	No.	2		3		4		6				
		Speed	rpm	920										
Motor input		W	1.75											
Compressor	Type	---	Semi-hermetic single screw compressor											
	Oil charge	l	13						16		19			
	Quantity	No.	1											
Sound level	Sound Power	Cooling	dB(A)	91.5		92.3		93.0		94.2		94.5		95.2
	Sound Pressure (2)	Cooling	dB(A)	73.5		73.7		73.9		75.1		75.0		75.3
Refrigerant circuit	Refrigerant type	---	R-134a											
	Refrigerant charge	kg.	17	20	22	27	29	32	45		54		58	
	N. of circuits	No.	1											
Piping connections	Suction	mm	76						139.7					
	Liquid	mm	28						35					
Safety devices	High discharge pressure (pressure switch)													
	High discharge pressure (pressure transducer)													
	Low suction pressure (pressure transducer)													
	Compressor motor protection													
	High discharge temperature													
	Low oil pressure													
	Low pressure ratio													
	High oil filter pressure drop													
	Phase monitor													
Notes (1)	Cooling capacity, unit power input in cooling and EER are based on the following conditions: SST 7°C; ambient 35°C, unit at full load operation.													
Notes (2)	The values are according to ISO 3744 and are referred to: SST 7°C, ambient 35°C, full load operation.													
Notes (3)	Refrigerant charge is for the unit only; doesn't include external suction and liquid line. Units are shipped without refrigerant charge; holding charge nitrogen 0.5 bar													

## 4 Technical specifications

4-1 Electrical Specifications		ERAD-E-SS	120	140	170	200	220	250	310	370	440	490	
Power Supply	Phase	---	3										
	Frequency	Hz	50										
	Voltage	V	400										
	Voltage Tolerance	Minimum	%	-10%									
		Maximum	%	+10%									
Unit	Maximum starting current	A	159		207		304		354	434			
	Nominal running current cooling	A	72	87	98	110	127	131	156	203	243	265	
	Maximum running current	A	88	104	119	133	161		195	248	288		
	Maximum current for wires sizing	A	97	114	131	146	177		215	273	317		
Fans	Nominal running current in cooling	A	8		12		16		24				
Compressor	Phase	No.	3										
	Voltage	V	400										
	Voltage Tolerance	Minimum	%	-10%									
		Maximum	%	+10%									
	Maximum running current	A	80	96	107	121	145		171	410	264		
	Starting method	---	Wye - Delta type (Y - Δ)										
Notes	Allowed voltage tolerance ± 10%. Voltage unbalance between phases must be within ± 3%.												
	Maximum starting current: starting current of biggest compressor + fans current.												
	Nominal current in cooling mode is referred to the following conditions: evaporator 12°C/7°C; ambient 35°C.compressor + fans current.												
	Maximum running current is based on max compressor absorbed current in its envelope and max fans absorbed current												
	Maximum unit current for wires sizing is based on minimum allowed voltage												
	Maximum current for wires sizing: (compressors full load ampere + fans current) x 1,1.												

## 4 Technical specifications

4-1 Technical Specifications			ERAD-E-SL	120	140	160	190	210	240	300	350	410	460		
Capacity (1)	Cooling	kW	116.0	137	159	187	209	243	295	352	409	462			
Capacity control	Type	---	Stepless												
	Minimum capacity	%	25												
Unit power input (1)	Cooling	kW	42.3	52.5	57.6	66.3	73.9	78.2	91.5	122	150	167			
EER (1)		---	2.74	2.61	2.75	2.82	2.83	3.11	3.23	2.88	2.73	2.76			
Casing	Colour	---	Ivory White												
	Material	---	Galvanized and painted steel sheet												
Dimensions	Unit	Height	2,273						2,223						
		Width	1,292						2,236						
		Length	2,165			3,065			3,965			3,070			
Weight	Unit	kg	1,712	1,738	1,851	1,897	2,046	2,091	2,534	2,741	2,834	2,870			
	Operating Weight	kg	1,742	1,771	1,886	1,937	2,088	2,136	2,595	2,805	2,907	2,950			
Air heat exchanger	Type	---	High efficiency fin and tube type with integral subcooler												
Fan	Type	---	Direct propeller type												
	Drive	---	DOL												
	Diameter	mm	800												
	Nominal air flow	l/s	8,372	8,144	12,558	12,217	16,744	16,289	25,117	24,433					
	Model	Quantity	No.	2		3		4		6					
		Speed	rpm	715											
Motor input		W	0.78												
Compressor	Type	---	Semi-hermetic single screw compressor												
	Oil charge	l	13						16		19				
	Quantity	No.	1												
Sound level	Sound Power	Cooling	89.0			89.8		90.5		91.7		92.0		92.7	
	Sound Pressure (2)	Cooling	71.0			71.2		71.4		72.6		72.5		72.8	
Refrigerant circuit	Refrigerant type	---	R-134a												
	Refrigerant charge	kg.	17	20	22	27	29	32	45	54	58				
	N. of circuits	No.	1												
Piping connections	Suction	mm	76								139.7				
	Liquid	mm	28						35						
Safety devices	High discharge pressure (pressure switch)														
	High discharge pressure (pressure transducer)														
	Low suction pressure (pressure transducer)														
	Compressor motor protection														
	High discharge temperature														
	Low oil pressure														
	Low pressure ratio														
	High oil filter pressure drop														
Phase monitor															
Notes (1)	Cooling capacity, unit power input in cooling and EER are based on the following conditions: SST 7°C; ambient 35°C, unit at full load operation.														
Notes (2)	The values are according to ISO 3744 and are referred to: SST 7°C, ambient 35°C, full load operation.														
Notes (3)	Refrigerant charge is for the unit only; doesn't include external suction and liquid line. Units are shipped without refrigerant charge; holding charge nitrogen 0.5 bar														

## 4 Technical specifications

4-1 Electrical Specifications		ERAD-E-SL	120	140	160	190	210	240	300	350	410	460	
Power Supply	Phase	---	3										
	Frequency	Hz	50										
	Voltage	V	400										
	Voltage Tolerance	Minimum	%	-10%									
		Maximum	%	+10%									
Unit	Maximum starting current	A	156		203		298		346	426			
	Nominal running current cooling	A	73	90	98	111	127	298	346	426			
	Maximum running current	A	85	101	115	129	155	133	154	203	248	274	
	Maximum current for wires sizing	A	94	111	126	142	171		205	264	308		
Fans	Nominal running current in cooling	A	5.2		7.8		10.4		15.6				
Compressor	Phase	No.	3										
	Voltage	V	400										
	Voltage Tolerance	Minimum	%	-10%									
		Maximum	%	+10%									
	Maximum running current	A	80	96	107	121	145		171	410	264		
	Starting method	---	Wye - Delta type (Y - Δ)										
Notes	Allowed voltage tolerance ± 10%. Voltage unbalance between phases must be within ± 3%.												
	Maximum starting current: starting current of biggest compressor + fans current												
	Nominal current in cooling mode is referred to the following conditions: evaporator 12°C/7°C; ambient 35°C.compressor + fans current.												
	Maximum running current is based on max compressor absorbed current in its envelope and max fans absorbed current												
	Maximum unit current for wires sizing is based on minimum allowed voltage												
	Maximum current for wires sizing: (compressors full load ampere + fans current) x 1,1.												

## 5 Sound Levels

### ERAD-E-SS

Unit size	Sound pressure level at 1 m from the unit in semispheric free field (rif. $2 \times 10^{-5}$ Pa)									Power
	63 Hz	125 Hz	250 Hz	500 Hz	1000 Hz	2000 Hz	4000 Hz	8000 Hz	dB(A)	dB(A)
120	75.5	70.8	68.9	75.3	64.3	61.7	53.0	47.3	73.5	91.5
140	75.5	70.8	68.9	75.3	64.3	61.7	53.0	47.3	73.5	91.5
170	75.7	71.0	69.1	75.5	64.5	61.9	53.2	47.5	73.7	92.3
200	75.7	71.0	69.1	75.5	64.5	61.9	53.2	47.5	73.7	92.3
220	75.9	71.2	69.3	75.7	64.7	62.1	53.4	47.7	73.9	93.0
250	77.1	72.4	70.5	76.9	65.9	63.3	54.6	48.9	75.1	94.2
310	77.0	72.3	70.4	76.8	65.8	63.2	54.5	48.8	75.0	94.2
370	77.3	72.6	70.7	77.1	66.1	63.5	54.8	49.1	75.3	94.5
440	77.3	72.6	70.7	77.1	66.1	63.5	54.8	49.1	75.3	94.5
490	78.0	73.3	71.4	77.8	66.8	64.2	55.5	49.8	76.0	95.2

### ERAD-E-SL

Unit size	Sound pressure level at 1 m from the unit in semispheric free field (rif. $2 \times 10^{-5}$ Pa)									Power
	63 Hz	125 Hz	250 Hz	500 Hz	1000 Hz	2000 Hz	4000 Hz	8000 Hz	dB(A)	dB(A)
120	73.0	68.3	66.4	72.8	61.8	59.2	50.5	44.8	71.0	89.0
140	73.0	68.3	66.4	72.8	61.8	59.2	50.5	44.8	71.0	89.0
160	73.2	68.5	66.6	73.0	62.0	59.4	50.7	45.0	71.2	89.8
190	73.2	68.5	66.6	73.0	62.0	59.4	50.7	45.0	71.2	89.8
210	73.4	68.7	66.8	73.2	62.2	59.6	50.9	45.2	71.4	90.5
240	74.6	69.9	68.0	74.4	63.4	60.8	52.1	46.4	72.6	91.7
300	74.5	69.8	67.9	74.3	63.3	60.7	52.0	46.3	72.5	91.7
350	74.8	70.1	68.2	74.6	63.6	61.0	52.3	46.6	72.8	92.0
410	74.8	70.1	68.2	74.6	63.6	61.0	52.3	46.6	72.8	92.0
460	75.5	70.8	68.9	75.3	64.3	61.7	53.0	47.3	73.5	92.7

### NOTES

The values are according to ISO 3744 and are referred to: evaporator 12/7° C, air ambient 35° C, full load operation

## 5 Sound Levels

Sound pressure level reduction values for different distances

Unit size		Distance						
ERAD-E-SS	ERAD-E-SL	1m	5m	10m	15m	20m	25m	50m
120	120	0.0	-8.8	-13.9	-17.1	-19.4	-21.2	-27.0
140	140	0.0	-8.8	-13.9	-17.1	-19.4	-21.2	-27.0
170	160	0.0	-8.5	-13.5	-16.6	-18.9	-20.7	-26.5
200	190	0.0	-8.5	-13.5	-16.6	-18.9	-20.7	-26.5
220	210	0.0	-8.2	-13.1	-16.2	-18.4	-20.3	-26.0
250	240	0.0	-8.2	-13.1	-16.2	-18.4	-20.3	-26.0
310	300	0.0	-8.1	-13.0	-16.1	-18.4	-20.2	-25.9
370	350	0.0	-8.1	-13.0	-16.1	-18.4	-20.2	-25.9
440	410	0.0	-8.1	-13.0	-16.1	-18.4	-20.2	-25.9
490	460	0.0	-8.1	-13.0	-16.1	-18.4	-20.2	-25.9



## 6 Operating limits

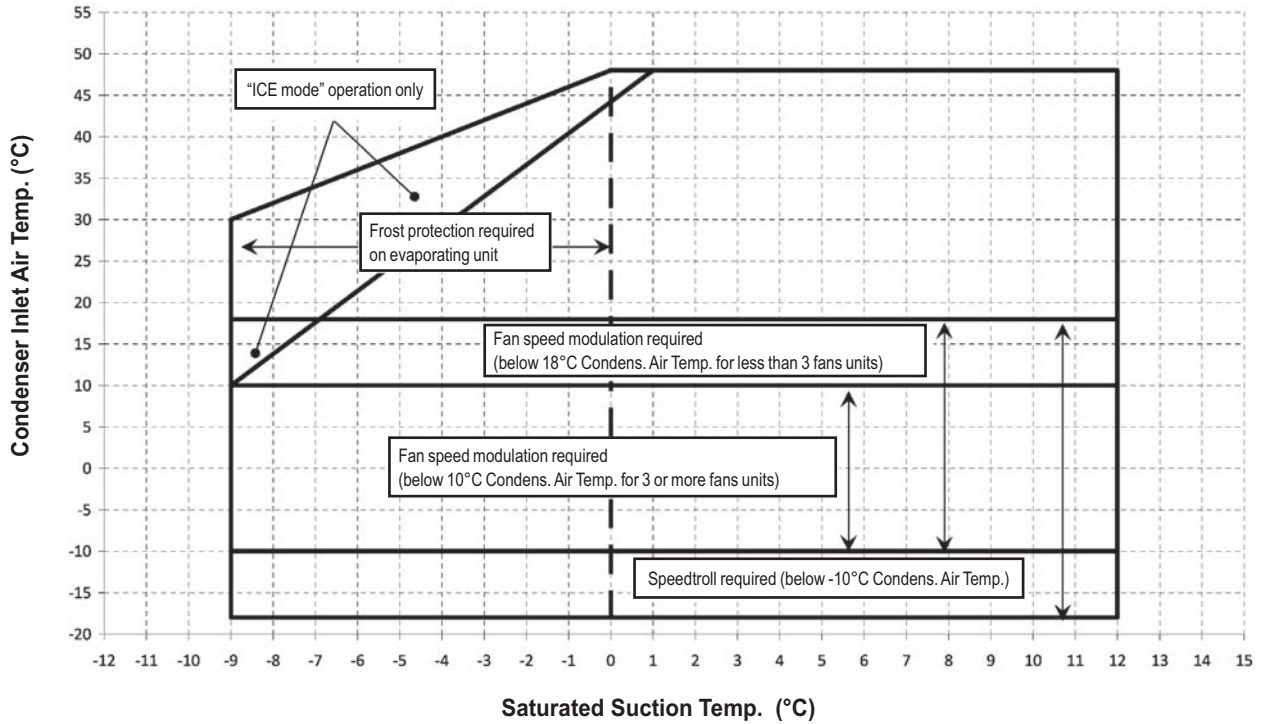

OPL\_1-2\_Rev.00\_1

**Table 1 - Air heat exchanger - Altitude correction factors**

Elevation above sea level (m)	0	300	600	900	1200	1500	1800
Barometric pressure (mbar)	1,013	977	942	908	875	843	812
Cooling capacity correction factor	1.000	0.993	0.986	0.979	0.973	0.967	0.960
Power input correction factor	1.000	1.005	1.009	1.015	1.021	1.026	1.031

- Maximum operating altitude is 2000 m above sea level
- Contact factory in case the unit has to be installed at altitudes between 1000 and 2000 m above sea level

OPL\_1-2\_Rev.00\_2

# 7 Standard rating

## 7 - 1 Cooling capacity tables

ERAD-E-SS		Condenser Inlet Air Temperature (°C)													
Size	SST (°C)	20		25		30		35		40		45		48	
		Cc (kW)	Pi (kW)	Cc (kW)	Pi (kW)	Cc (kW)	Pi (kW)	Cc (kW)	Pi (kW)	Cc (kW)	Pi (kW)	Cc (kW)	Pi (kW)	Cc (kW)	Pi (kW)
120	-9	80.6	25.6	76.3	27.9	71.7	30.4	66.7	33.2	61.6	36.2	56.0	39.4	52.5	41.5
	-7	87.0	26.3	82.5	28.7	77.8	31.2	72.7	34.0	67.3	37.1	61.6	40.3	57.9	42.4
	-5	93.8	27.1	89.1	29.5	84.0	32.1	78.8	34.9	73.2	38.0	67.3	41.3	63.6	43.4
	-3	101	28.0	95.9	30.4	90.7	33.1	85.2	35.9	79.3	39.0	73.1	42.4	69.3	44.5
	-1	108	29.0	103	31.4	97.5	34.1	91.8	37.0	85.7	40.1	79.3	43.5	75.3	45.6
	1	116	30.0	111	32.5	105	35.2	98.7	38.1	92.4	41.2	85.7	44.6	81.5	46.8
	3	124	31.1	118	33.6	112	36.3	106	39.3	99.2	42.4	92.2	45.8	87.2	47.6
	5	132	32.3	126	34.8	120	37.6	113	40.5	106	43.7	99.1	47.1	88.7	45.8
	7	141	33.5	135	36.1	128	38.8	121	41.8	114	45.0	106	48.5	90.3	44.2
	9	150	34.8	143	37.4	136	40.2	129	43.2	121	46.4	111	48.5	92.4	43.1
	11	160	36.2	152	38.8	145	41.6	137	44.6	129	47.9	113	47.0	93.0	41.4
	13	164	36.9	157	39.5	149	42.3	142	45.4	133	48.6	113	46.2	94.0	41.0
	140	-9	97.0	30.7	91.7	33.5	86.0	36.6	80.0	40.0	73.6	43.7	66.8	47.6	62.5
-7		105	31.7	99.2	34.6	93.3	37.7	87.0	41.1	80.4	44.8	73.4	48.8	69.0	51.3
-5		113	32.8	107	35.7	101	38.9	94.3	42.3	87.4	46.0	80.2	50.0	75.6	52.6
-3		121	33.9	115	36.9	109	40.1	102	43.5	94.8	47.3	87.2	51.3	82.5	53.9
-1		130	35.1	124	38.1	117	41.4	110	44.9	102	48.7	94.5	52.7	89.5	55.3
1		139	36.4	132	39.4	125	42.7	118	46.3	110	50.1	102	54.2	94.8	55.3
3		149	37.8	142	40.9	134	44.2	126	47.7	118	51.6	110	55.8	96.5	53.1
5		159	39.3	151	42.4	143	45.7	135	49.3	127	53.2	118	57.4	98.6	51.3
7		169	40.8	161	43.9	153	47.3	144	51.0	135	54.9	121	56.3	101	50.0
9		180	42.4	171	45.6	163	49.0	154	52.7	144	56.7	124	54.5	102	48.0
11		191	44.2	182	47.4	173	50.8	163	54.5	154	58.6	125	52.6	104	47.0
13		196	45.0	187	48.3	178	51.8	168	55.5	158	59.5	126	51.6	104	46.0
170		-9	109	35.7	103	38.9	96.8	42.3	90.3	46.0	83.5	50.1	76.1	54.6	71.5
	-7	117	36.7	111	40.0	105	43.4	98.4	47.2	91.3	51.3	83.6	55.9	78.8	58.9
	-5	126	37.9	120	41.1	114	44.6	107	48.4	99.3	52.6	91.5	57.3	86.4	60.3
	-3	136	39.1	130	42.3	123	45.9	115	49.7	108	54.0	99.5	58.7	94.3	61.8
	-1	146	40.3	139	43.6	132	47.2	125	51.1	116	55.4	108	60.2	102	63.4
	1	157	41.6	150	45.0	142	48.6	134	52.5	126	56.9	117	61.8	111	65.0
	3	168	43.0	160	46.4	152	50.0	144	54.1	135	58.5	126	63.4	120	66.7
	5	179	44.5	171	47.9	163	51.6	154	55.7	145	60.2	135	65.2	129	68.5
	7	191	46.1	183	49.5	174	53.3	165	57.4	155	62.0	145	67.0	134	67.8
	9	204	47.8	195	51.3	186	55.1	176	59.2	166	63.8	155	69.0	137	65.7
	11	217	49.6	207	53.1	197	56.9	187	61.2	177	65.8	165	71.1	138	63.4
	13	223	50.6	214	54.1	204	57.9	193	62.2	182	66.9	168	70.9	140	62.9
	200	-9	130	39.8	123	43.5	116	47.5	108	51.9	100	56.6	90.7	61.7	85.2
-7		140	41.1	133	44.8	125	48.8	117	53.2	109	58.0	100	63.1	93.8	66.4
-5		151	42.4	144	46.1	136	50.2	127	54.7	118	59.5	109	64.7	103	68.0
-3		163	43.8	155	47.6	146	51.7	138	56.2	128	61.0	118	66.2	112	69.6
-1		175	45.3	166	49.1	158	53.3	148	57.8	139	62.7	128	67.9	122	71.3
1		187	46.9	178	50.7	169	54.9	160	59.5	149	64.4	139	69.7	132	73.1
3		200	48.5	191	52.5	181	56.7	171	61.3	161	66.3	149	71.6	142	75.0
5		214	50.3	204	54.3	194	58.6	183	63.2	172	68.2	161	73.6	150	75.0
7		228	52.2	218	56.2	207	60.5	196	65.2	184	70.3	172	75.7	153	72.7
9		243	54.2	232	58.2	221	62.6	209	67.3	197	72.4	184	77.9	155	70.2
11		258	56.3	247	60.4	235	64.8	222	69.6	210	74.7	190	77.3	157	67.7
13		266	57.4	254	61.5	242	65.9	229	70.7	216	75.9	192	76.1	159	67.1
220		-9	145	45.6	137	49.7	129	54.1	120	59.0	111	64.5	99.5	70.8	91.7
	-7	156	46.9	148	51.1	140	55.5	131	60.5	121	66.1	109	72.4	101	76.7
	-5	169	48.4	160	52.5	152	57.0	142	62.0	132	67.7	119	74.2	110	78.5
	-3	182	49.9	173	54.1	164	58.7	154	63.7	143	69.5	129	76.0	120	80.3
	-1	195	51.5	186	55.8	177	60.4	166	65.5	154	71.3	140	77.9	130	82.3
	1	210	53.3	200	57.5	190	62.2	178	67.4	166	73.3	150	79.9	140	84.3
	3	224	55.1	214	59.4	204	64.1	191	69.4	178	75.3	161	82.1	150	86.5
	5	240	57.0	229	61.4	218	66.2	205	71.5	190	77.5	173	84.3	161	88.8
	7	256	59.1	245	63.5	232	68.3	219	73.7	203	79.9	184	86.7	172	91.3
	9	273	61.3	261	65.7	248	70.6	233	76.1	216	82.3	196	89.3	179	90.4
	11	291	63.6	278	68.1	263	73.1	247	78.6	229	84.9	209	92.0	182	87.5
	13	300	64.8	286	69.3	271	74.3	255	80.0	236	86.3	215	93.3	184	86.0
	250	-9	162	46.7	157	51.8	152	57.0	146	62.7	138	69.1	126	76.4	118
-7		173	47.8	169	53.0	164	58.3	158	64.1	149	70.6	138	78.1	129	83.0
-5		185	49.0	181	54.3	177	59.7	170	65.6	161	72.3	149	79.8	140	84.8
-3		198	50.3	194	55.6	190	61.2	183	67.2	173	74.0	160	81.6	151	86.7
-1		210	51.7	207	57.1	203	62.7	196	68.9	186	75.8	172	83.6	162	88.7
1		224	53.1	221	58.6	217	64.4	209	70.7	199	77.7	184	85.6	174	90.8
3		238	54.7	235	60.3	231	66.1	223	72.5	212	79.6	196	87.7	185	93.0
5		253	56.3	250	62.0	245	68.0	237	74.5	225	81.7	209	89.9	197	95.2
7		268	58.1	266	63.9	260	69.9	252	76.6	239	83.9	222	92.2	205	94.9
9		284	60.0	282	65.8	276	72.0	266	78.7	253	86.2	234	94.6	209	92.3
11		301	62.0	298	67.9	292	74.2	281	81.1	267	88.7	248	97.2	212	89.7
13		310	63.0	307	69.0	300	75.3	289	82.3	274	89.9	254	98.5	213	87.8

**NOTES**

Cc (cooling capacity) - Pi (unit power input) - SST (compressor saturated suction temperature)

# 7 Standard rating

## 7 - 1 Cooling capacity tables

ERAD-E-SS															
Size	SST (°C)	Condenser Inlet Air Temperature (°C)													
		20		25		30		35		40		45		48	
		Cc (kW)	Pi (kW)	Cc (kW)	Pi (kW)	Cc (kW)	Pi (kW)	Cc (kW)	Pi (kW)	Cc (kW)	Pi (kW)	Cc (kW)	Pi (kW)	Cc (kW)	Pi (kW)
310	-9	200	58.5	189	63.5	179	69	168	76.1	157	84.1	143	93.7	134	100
	-7	216	60.2	205	65.2	194	71	183	77.6	170	85.4	156	94.8	146	101
	-5	233	62.0	222	67.0	210	73	198	79.2	185	86.9	169	96.1	159	102
	-3	251	64.0	239	68.9	227	75	214	81.0	200	88.6	184	97.6	173	104
	-1	270	66.2	258	71.1	245	77	231	83.0	216	90.5	198	99.3	187	105
	1	291	68.5	277	73.4	263	79	249	85.2	232	92.6	214	101	202	107
	3	312	71.0	297	75.9	283	81	267	87.5	250	94.8	230	103	217	109
	5	334	73.7	318	78.5	303	84	286	90.1	268	97.3	247	106	233	111
	7	356	76.6	341	81.4	324	87	306	92.8	286	100	265	108	250	114
	9	380	79.7	363	84.4	346	90	327	95.8	306	103	283	111	267	116
	11	405	82.9	387	87.6	369	93	348	98.9	326	106	302	114	286	119
	13	418	84.6	400	89.3	380	95	359	101	337	108	311	115	288	118
	370	-9	248	74.4	234	80.0	221	86	207	91.9	192	98.4	174	106	162
-7		268	77.1	254	82.8	240	89	225	95.1	208	102	189	109	177	114
-5		289	79.9	274	85.8	259	92	243	99	225	106	205	113	192	118
-3		311	82.8	295	88.9	279	95	262	102	243	109	222	117	208	122
-1		334	85.9	318	92.2	301	99	282	106	262	113	239	121	224	126
1		359	89.2	341	95.6	323	102	303	110	281	117	257	125	241	130
3		384	92.6	365	99.2	346	106	325	114	301	121	276	130	259	135
5		410	96.2	391	103	370	110	347	118	322	126	295	134	269	136
7		438	100	417	107	394	114	370	122	344	130	315	139	273	133
9		466	104	444	111	420	119	394	127	366	135	335	144	275	128
11		496	108	472	116	446	123	419	131	389	140	339	141	281	125
13		511	110	486	118	460	126	432	134	401	143	340	138	282	123
440		-9	294	88.5	278	95.3	262	102	246	110	227	118	205	126	191
	-7	318	91.9	301	98.8	284	106	266	114	246	122	223	131	208	136
	-5	343	95.4	325	103	307	110	288	118	266	126	241	135	225	141
	-3	369	99.1	350	106	331	114	310	122	287	131	261	140	243	146
	-1	396	103	376	111	356	118	333	127	308	136	281	145	262	152
	1	425	107	404	115	382	123	358	132	331	141	301	151	282	157
	3	455	111	432	119	408	128	383	137	354	146	323	156	294	158
	5	485	116	462	124	436	133	409	142	378	152	345	162	296	153
	7	517	121	492	129	465	138	435	147	403	157	368	168	302	149
	9	551	126	523	134	495	143	463	153	429	163	370	163	306	144
	11	585	131	556	140	525	149	492	159	455	169	376	159	311	140
	13	602	134	572	143	540	152	506	162	469	173	379	157	311	137
	490	-9	325	94.5	315	103	304	112	292	121	277	131	256	143	240
-7		349	97.9	338	107	327	116	314	125	297	136	275	148	258	156
-5		374	101	362	111	351	120	337	130	318	141	294	153	277	161
-3		400	105	388	115	375	124	360	134	340	146	315	158	288	162
-1		427	109	414	119	401	129	384	139	363	151	335	164	293	159
1		455	113	442	123	427	133	409	144	386	156	357	169	298	155
3		484	118	470	128	454	138	435	150	410	162	365	168	300	149
5		515	122	500	133	482	144	461	155	434	167	370	164	304	145
7		546	127	530	138	511	149	488	161	459	174	372	159	309	141
9		579	132	561	143	541	155	516	167	485	180	377	155	313	137
11		613	138	594	149	571	161	544	173	493	178	383	152	316	133
13		630	141	610	152	587	164	558	176	494	176	386	150	317	130

**NOTES**

Cc (cooling capacity) - Pi (unit power input) – SST (compressor saturated suction temperature)

# 7 Standard rating

## 7 - 1 Cooling capacity tables

### ERAD-E-SL

Size	SST (°C)	Condenser Inlet Air Temperature (°C)													
		20		25		30		35		40		45		48	
		Cc (kW)	Pi (kW)	Cc (kW)	Pi (kW)	Cc (kW)	Pi (kW)	Cc (kW)	Pi (kW)	Cc (kW)	Pi (kW)	Cc (kW)	Pi (kW)	Cc (kW)	Pi (kW)
120	-9	78.7	24.9	74.3	27.3	69.6	29.9	64.6	32.7	59.3	35.8	53.7	39.1	50.2	41.2
	-7	84.9	25.7	80.3	28.2	75.4	30.8	70.2	33.7	64.8	36.8	58.9	40.1	55.3	42.3
	-5	91.4	26.6	86.6	29.1	81.5	31.8	76.1	34.7	70.5	37.8	64.4	41.2	60.6	43.4
	-3	98.2	27.6	93	30.1	88	32.9	82.2	35.8	76.2	39.0	70.0	42.4	66.0	44.5
	-1	105	28.7	100	31.2	94	34.0	88.5	37.0	82.3	40.2	75.8	43.6	69.1	43.7
	1	113	29.8	107	32.4	101	35.2	95.1	38.2	88.6	41.4	81.8	44.9	70.7	41.9
	3	120	31.1	114	33.7	108	36.5	102	39.5	95.1	42.8	88.0	46.3	72.2	40.4
	5	128	32.3	122	35.0	116	37.8	109	40.9	102	44.2	89.5	44.5	73.3	38.9
	7	136	33.7	130	36.4	123	39.2	116	42.3	109	45.6	91.3	42.9	74.7	37.7
	9	145	35.1	138	37.8	131	40.7	123	43.8	116	47.2	92.5	41.4	76.4	36.8
	11	154	36.6	146	39.4	139	42.3	131	45.4	121	47.9	94.0	40.1	76.8	35.5
	13	158	37.4	151	40.1	143	43.1	135	46.2	122	47.1	94.1	39.3	77.4	35.0
	140	-9	94.1	30.5	88.7	33.5	82.9	36.7	76.8	40.1	70.2	43.9	63.3	47.9	58.9
-7		102	31.6	95.9	34.6	89.8	37.9	83.5	41.4	76.7	45.2	69.5	49.3	65.0	51.9
-5		109	32.8	103	35.9	97	39.2	90.4	42.7	83.3	46.6	75.9	50.7	70.8	52.8
-3		117	34.1	111	37.2	104	40.5	97.5	44.1	90.2	48.0	82.5	52.2	72.7	50.3
-1		126	35.5	119	38.6	112	42.0	105	45.6	97.3	49.6	89.3	53.8	75.2	48.6
1		134	37.0	127	40.1	120	43.5	113	47.2	105	51.2	93.6	53.3	76.3	46.4
3		143	38.5	136	41.7	128	45.2	121	48.9	112	52.9	95.4	51.1	78.3	45.1
5		152	40.2	145	43.4	137	46.9	129	50.7	120	54.7	97.2	49.3	79.7	43.6
7		162	41.9	154	45.2	146	48.7	137	52.5	128	56.6	98.6	47.4	80.6	42.1
9		172	43.7	163	47.1	155	50.6	146	54.5	131	55.0	100	45.9	82.1	41.0
11		182	45.7	173	49.0	164	52.7	154	56.6	132	53.1	101	44.4	83.0	39.9
13		187	46.7	178	50.1	169	53.7	159	57.6	133	52.1	102	43.9	83.2	39.3
160		-9	106	34.4	101	37.6	94	41.1	87.8	44.9	80.8	49.1	73.3	53.8	68.6
	-7	115	35.5	109	38.8	102	42.4	95.5	46.2	88.3	50.5	80.4	55.3	75.6	58.4
	-5	124	36.8	117	40.1	111	43.7	104	47.6	96.0	52.0	88.0	56.8	82.8	60.0
	-3	133	38.1	126	41.4	119	45.1	112	49.1	104	53.5	95.7	58.4	90.3	61.6
	-1	143	39.4	136	42.8	128	46.5	121	50.6	112	55.1	104	60.1	98.2	63.4
	1	153	40.9	145	44.3	138	48.1	130	52.2	121	56.8	112	61.9	105	64.0
	3	163	42.4	156	45.9	147	49.7	139	53.9	130	58.5	121	63.7	108	62.0
	5	174	44.1	166	47.6	158	51.4	149	55.7	139	60.4	129	65.7	110	59.9
	7	186	45.8	177	49.4	168	53.3	159	57.6	149	62.4	135	65.8	112	57.7
	9	197	47.7	188	51.3	179	55.3	169	59.7	159	64.5	137	63.0	114	56.0
	11	210	49.7	200	53.3	190	57.4	180	61.8	169	66.8	140	61.4	115	54.2
	13	216	50.7	206	54.4	196	58.4	185	63.0	174	68.0	140	60.2	116	53.6
	190	-9	127	39.0	120	42.8	112	46.9	104	51.4	95.7	56.2	86.7	61.4	81.1
-7		137	40.3	129	44.2	122	48.4	113	52.9	105	57.8	95.2	63.1	89.4	66.4
-5		147	41.8	139	45.7	131	49.9	123	54.5	114	59.4	104	64.8	98.0	68.1
-3		158	43.4	150	47.3	142	51.6	133	56.2	123	61.2	113	66.6	107	70.0
-1		169	45.0	161	49.0	152	53.3	143	58.0	133	63.0	122	68.5	114	70.6
1		181	46.8	172	50.8	163	55.2	153	59.9	143	65.0	132	70.5	117	67.8
3		194	48.7	184	52.8	175	57.2	164	61.9	153	67.1	142	72.6	120	65.5
5		207	50.7	197	54.8	186	59.3	176	64.1	164	69.2	148	71.9	122	63.1
7		220	52.8	209	56.9	199	61.5	187	66.3	176	71.5	150	68.9	124	61.2
9		234	55.0	223	59.2	211	63.8	199	68.7	187	74.0	153	67.2	126	59.3
11		248	57.3	236	61.6	224	66.2	212	71.2	199	76.5	155	64.6	127	57.2
13		255	58.6	243	62.9	231	67.5	218	72.5	202	76.4	157	64.0	128	56.5
210		-9	141	43.7	134	47.9	126	52.4	117	57.5	107	63.2	95.0	69.8	86.7
	-7	153	45.2	145	49.4	136	54.0	127	59.2	117	65.0	104	71.6	95.3	76.0
	-5	165	46.8	156	51.0	148	55.7	138	60.9	127	66.8	113	73.5	104	78.0
	-3	177	48.4	169	52.7	159	57.5	149	62.8	137	68.8	123	75.6	113	80.1
	-1	190	50.2	181	54.6	171	59.4	160	64.8	147	70.9	132	77.7	122	82.2
	1	204	52.1	194	56.5	184	61.4	172	66.9	158	73.0	142	80.0	131	84.6
	3	218	54.1	208	58.6	197	63.5	184	69.1	169	75.3	152	82.4	140	86.2
	5	233	56.2	222	60.8	210	65.8	196	71.4	181	77.8	162	84.9	143	82.6
	7	249	58.5	237	63.1	224	68.2	209	73.9	192	80.4	173	87.5	146	79.8
	9	265	60.9	252	65.6	238	70.8	222	76.6	204	83.1	180	87.8	149	76.7
	11	281	63.4	267	68.2	252	73.5	235	79.4	216	86.0	184	84.9	152	74.5
	13	289	64.8	275	69.6	259	74.9	242	80.9	222	87.5	185	83.3	152	72.8
	240	-9	160	45.5	155	50.6	150	56.0	142	61.9	133	68.7	120	76.3	111
-7		171	46.8	167	52.0	162	57.5	154	63.6	144	70.5	131	78.3	121	83.5
-5		183	48.2	179	53.5	174	59.1	166	65.4	156	72.4	142	80.3	131	85.6
-3		196	49.6	192	55.1	186	60.9	178	67.2	167	74.4	152	82.5	142	87.8
-1		209	51.2	205	56.8	199	62.7	191	69.2	179	76.5	163	84.7	152	90.1
1		222	52.9	219	58.6	212	64.6	203	71.3	191	78.7	174	87.0	158	88.8
3		236	54.7	233	60.5	226	66.6	216	73.4	203	81.0	185	89.5	162	85.6
5		251	56.6	247	62.5	240	68.8	229	75.7	215	83.5	196	92.0	164	82.1
7		267	58.7	262	64.6	254	71.1	243	78.2	227	86.0	202	90.8	167	79.4
9		283	60.8	278	66.9	269	73.5	257	80.7	240	88.7	205	87.3	170	77.5
11		299	63.2	293	69.4	284	76.1	270	83.4	253	91.5	208	84.6	171	74.6
13		307	64.4	301	70.6	292	77.4	277	84.8	259	93.0	210	83.7	172	73.6

**NOTES**

Cc (cooling capacity) - Pi (unit power input) - SST (compressor saturated suction temperature)

# 7 Standard rating

## 7 - 1 Cooling capacity tables

ERAD-E-SL															
Size	SST (°C)	Condenser Inlet Air Temperature (°C)													
		20		25		30		35		40		45		48	
		Cc (kW)	Pi (kW)	Cc (kW)	Pi (kW)	Cc (kW)	Pi (kW)	Cc (kW)	Pi (kW)	Cc (kW)	Pi (kW)	Cc (kW)	Pi (kW)	Cc (kW)	Pi (kW)
300	-9	185	58.9	186	60.3	175	66.3	164	73.5	152	82.0	138	92.0	128	98.9
	-7	200	61.0	201	62.0	190	68.0	178	75.1	165	83.4	150	93.3	140	100.0
	-5	223	60.4	217	64.0	205	69.9	193	76.9	179	85.1	163	94.7	152	101.3
	-3	240	62.7	234	66.1	222	72.0	208	78.8	194	86.9	176	96.4	165	102.8
	-1	264	63.3	252	68.4	239	74.2	224	81.0	208	88.9	190	98.2	178	104.5
	1	284	65.7	270	70.8	256	76.6	241	83.3	224	91.2	205	100.3	192	106.4
	3	304	68.4	290	73.4	275	79.2	258	85.8	240	93.6	220	102.6	206	108.6
	5	325	71.2	310	76.3	294	82.0	277	88.6	257	96.2	236	105.1	221	111.0
	7	347	74.3	331	79.3	314	85.0	295	91.5	275	99.1	252	107.8	228	109.1
	9	369	77.5	352	82.5	334	88.2	315	94.6	293	102.1	269	110.7	233	105.6
	11	393	80.9	375	85.9	356	91.6	335	98.0	312	105.4	286	113.9	237	101.7
	13	405	82.7	386	87.7	367	93.3	345	100	321	107.1	289	112.8	238	99.6
	350	-9	242	71.7	229	77.3	215	83.2	201	89.4	185	96.0	166	103.2	154
-7		261	74.7	247	80.4	233	86.5	218	92.9	200	99.8	181	107.2	167	111.9
-5		281	77.8	266	83.7	251	90.0	235	96.6	216	103.7	195	111.3	181	116.2
-3		302	81.0	287	87.2	270	93.6	253	100	233	107.7	211	115.6	196	120.6
-1		324	84.4	308	90.8	290	97.4	271	104	250	112.0	226	120.1	211	125.2
1		347	88.1	330	94.5	311	101.4	291	109	268	116.4	243	124.7	215	123.5
3		371	91.9	353	98.5	332	105.6	311	113	286	121.0	259	129.5	219	120.2
5		396	95.9	376	102.7	355	110.0	331	118	305	125.8	270	130.6	222	115.7
7		422	100.1	400	107.1	377	114.6	352	122	325	130.8	273	127.2	227	112.9
9		448	104.5	425	111.8	401	119.4	374	128	345	136.1	278	123.9	228	108.0
11		475	109.2	451	116.6	425	124.5	396	133	365	141.6	281	119.8	234	105.3
13		489	111.7	464	119.2	437	127.1	407	136	366	139.6	283	117.3	236	103.8
410		-9	286	87.0	270	93.7	254	100.8	236	108	217	116.4	194	125.1	179
	-7	308	90.7	292	97.7	274	105.0	256	113	234	121.1	210	130.1	194	135.8
	-5	332	94.6	314	101.8	296	109.4	276	117	253	126.0	227	135.3	210	141.1
	-3	356	98.8	338	106.2	318	114.0	296	122	272	131.1	244	140.6	225	146.1
	-1	382	103.1	362	110.7	341	118.8	317	127	291	136.5	262	146.2	229	142.6
	1	409	107.7	387	115.5	365	123.8	339	133	312	142.0	281	152.1	231	137.3
	3	437	112.5	414	120.6	389	129.1	362	138	332	147.8	288	151.0	236	133.3
	5	465	117.6	441	125.9	414	134.7	385	144	354	153.9	293	146.9	242	129.9
	7	495	123.0	468	131.5	440	140.6	409	150	376	160.3	298	143.0	246	125.7
	9	525	128.7	497	137.5	466	146.7	434	157	391	162.9	302	137.9	249	120.8
	11	556	134.7	526	143.7	493	153.2	458	163	395	158.4	307	133.6	254	116.9
	13	571	137.8	540	146.9	507	156.5	471	167	398	156.5	307	130.3	256	114.8
	460	-9	319	94.4	308	103.0	297	112.0	284	122	265	132.9	241	145.3	219
-7		342	98.3	331	107.2	319	116.5	304	127	284	138.0	258	150.7	224	146.6
-5		366	102.4	355	111.6	342	121.2	325	132	303	143.4	276	156.3	227	141.7
-3		391	106.7	379	116.2	365	126.2	347	137	323	149.0	284	156.1	231	137.3
-1		417	111.3	404	121.1	388	131.4	369	143	344	154.8	287	151.5	235	133.8
1		444	116.1	430	126.2	413	136.8	391	148	364	160.8	291	147.0	241	130.7
3		472	121.2	457	131.6	438	142.6	414	154	385	167.1	296	143.1	243	125.2
5		501	126.6	484	137.3	463	148.6	438	161	390	164.6	300	138.4	249	122.7
7		531	132.4	512	143.3	489	154.9	462	167	394	160.3	305	134.9	251	117.9
9		561	138.4	541	149.7	516	161.5	486	174	400	156.7	309	130.7	256	114.7
11		592	144.8	569	156.4	543	168.5	497	174.5	404	152.2	311	126.1	259	111.1
13		608	148.2	584	159.9	556	172.1	499	172.4	403	148.6	312	123.6	258	108.2

**NOTES**

Cc (cooling capacity) - Pi (unit power input) - SST (compressor saturated suction temperature)



## 8 Options

### Partial Heat Recovery pressure drops

	ERAD-E-SS	120	140	170	200	220	250	310	370	440	490
	ERAD-E-SL	120	140	160	190	210	240	300	350	410	460
Heating Capacity (kW)		125	150	171	200	224	263	311	377	393	392
Water Flow (l/s)		5.98	7.15	8.15	9.54	10.71	12.56	14.87	18.01	18.76	18.72
Heat Recovery Pressure Drops (kPa)		33	37	41	44	46	49	29	34	27	23

#### NOTES

Water flow and pressure drop referred to nominal condition: SST 7°C – condenser air inlet 35°C – water heat recovery in/out 40/45°C

OPT\_1-2-3-4-5\_Rev.00\_3

### Partial Heat Recovery pressure drops

	ERAD-E-SS	120	140	170	200	220	250	310	370	440	490
	ERAD-E-SL	120	140	160	190	210	240	300	350	410	460
Heating Capacity (kW)		50.3	60.3	68.6	80	90	105	125	151	153	153
Water Flow (l/s)		2.40	2.88	3.28	3.84	4.31	5.03	5.96	7.22	7.31	7.29
Heat Recovery Pressure Drops (kPa)		6	7	8	8	9	10	6	7	5	4

#### NOTES

Water flow and pressure drop referred to nominal condition: SST 7°C – condenser air inlet 35°C – water heat recovery in/out 50/60°C

OPT\_1-2-3-4-5\_Rev.00\_4

## 8 Options

### Total and Partial Heat Recovery Pressure Drops

To determine the pressure drop for different versions or at different working condition, please refer to the following formula:

$$PD_2 \text{ (kPa)} = PD_1 \text{ (kPa)} \times \left( \frac{Q_2 \text{ (l/s)}}{Q_1 \text{ (l/s)}} \right)^{1.80}$$

where:

- $PD_2$  Pressure drop to be determinate (kPa)
- $PD_1$  Pressure drop at nominal condition (kPa)
- $Q_2$  water flow at new working condition (l/s)
- $Q_1$  water flow at nominal condition (l/s)

### How to use the formula: Example

The unit ERAD120E-SS has been selected for working at the following conditions:

- Total heat recovery leaving water temperature 40/50°C
- The heating capacity at these working conditions is: 121 kW
- The water flow at these working conditions is: 2.89 l/s

The unit ERAD120E-SS at nominal working conditions has the following data:

- Total heat recovery leaving water temperature 40/45°C
- condenser air inlet: 35°C
- The heating capacity at these working conditions is: 125 kW
- The water flow at these working conditions is: 5.98 l/s
- The pressure drop at these working conditions is: 33 kPa

The pressure drop at the selected working condition will be:

$$PD_2 \text{ (kPa)} = 33 \text{ (kPa)} \times \left( \frac{2.89 \text{ (l/s)}}{5.98 \text{ (l/s)}} \right)^{1.80}$$

$$PD_2 \text{ (kPa)} = 9 \text{ (kPa)}$$

OPT\_1-2-3-4-5\_Rev.00\_5



## 9 Dimensions

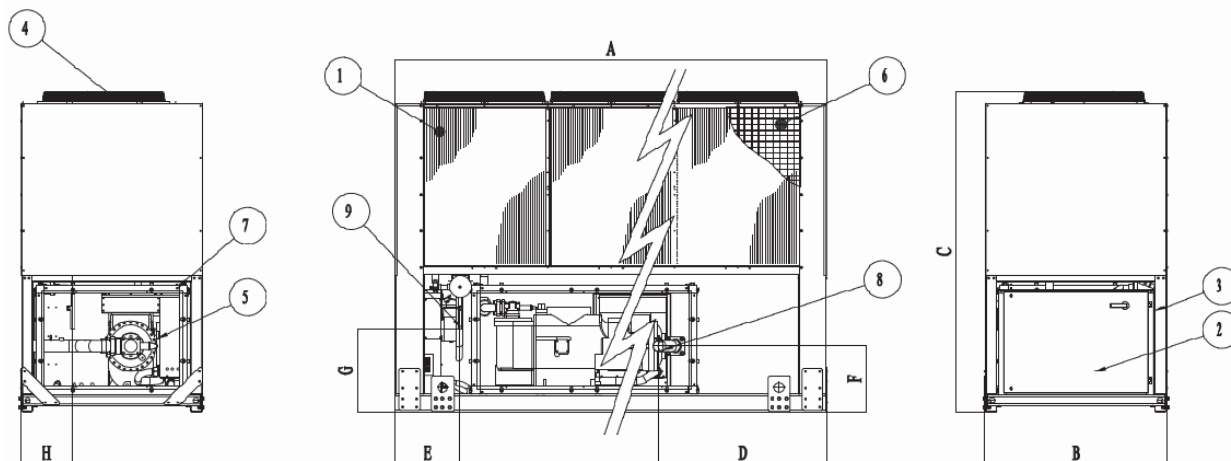

Size		Dimensions								
E-SS	E-SL	A	B	C	D	E	F	G	H	Fans
120	120	2165	1292	2273	298	460	466	587	366	2
140	140	2165	1292	2273	298	460	466	587	366	2
170	160	3065	1292	2273	1198	460	466	587	366	3
200	190	3065	1292	2273	1198	460	466	587	366	3
220	210	3965	1292	2273	2098	460	466	587	416	4
250	240	3965	1292	2273	2098	460	466	587	416	4

### LEGEND

- 1 - Air heat exchanger (condenser)
- 2 - Electrical control panel
- 3 - Slot for power and control connection
- 4 - Fan
- 5 - Compressor
- 6 - Coil protection guards (optional)
- 7 - Compressor sound enclosure (optional)
- 8 - Suction welding connection
- 9 - Liquid line brazing connection

## 9 Dimensions

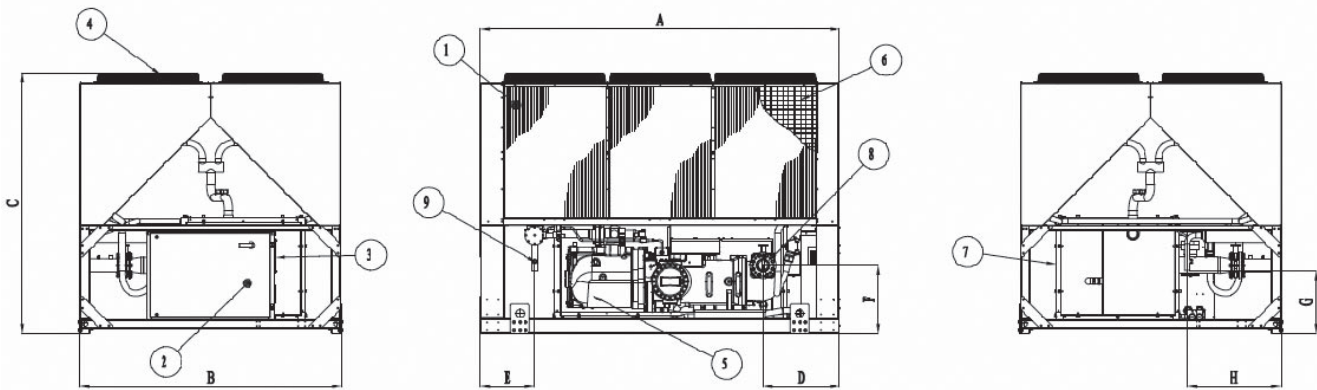

Size		Dimensions								
E-SS	E-SL	A	B	C	D	E	F	G	H	Fans
310	300	3070	2236	2223	652	465	581	537	800	6
370	350	3070	2236	2223	652	465	581	537	800	6
440	410	3070	2236	2223	652	465	581	537	800	6
490	460	3070	2236	2223	652	465	581	537	800	6

### LEGEND

- 1 - Air heat exchanger (condenser)
- 2 - Electrical control panel
- 3 - Slot for power and control connection
- 4 - Fan
- 5 - Compressor
- 6 - Coil protection guards (optional)
- 7 - Compressor sound enclosure (optional)
- 8 - Suction welding connection
- 9 - Liquid line brazing connection

## 10 Installation notes

### Warning

Installation and maintenance of the unit must be performed only by qualified personnel who has knowledge with local codes and regulations, and experience with this type of equipment. The unit must be installed to allow all the maintenance operations.

### Handling

Care should be taken to avoid rough handling or shock due to dropping of the unit. Do not push or pull the unit from anything other than the base frame. Never allow the unit to fall during unloading or moving as this may result in serious damage. To lift the unit, rings are provided in the base frame of the unit. Spreader bar and cables should be arranged to prevent damage to the condenser coil or unit cabinet.

### Location

The units are produced for outside installation on roofs, floors or below ground level on condition that the area is free from obstacles for the passage of the condenser air. The unit should be positioned on solid foundations and perfectly level; in the case of installation on roofs or floors, it may be advisable to arrange the use of suitable weight distribution beams. When the units are installed on the ground, a concrete base at least 250 mm wider and longer than the unit's footprint should be laid. Furthermore, this base should withstand the unit weight mentioned in the technical data table.

### Space requirements

The units are air-cooled, then it is important to respect the minimum distances which guarantee the best ventilation of the condenser coils. Limitations of space reducing the air flow could cause significant reductions in cooling capacity and an increase in electricity consumption.

To determinate unit placement, careful consideration must be given to assure a sufficient air flow across the condenser heat transfer surface. Two conditions must be avoided to achieve the best performance: warm air recirculation and coil starvation. Both these conditions cause an increase of condensing pressures that result in reductions in unit efficiency and capacity.

Moreover the unique microprocessor has the ability to analyse the operating environment of the air cooled condensing unit and to optimize its performance to stay on-line during abnormal conditions.

Each side of the unit must be accessible after installation for periodic service. Fig.1 and 2 show you minimum recommended clearance requirements.

Vertical condenser air discharge must be unobstructed because the unit would have its capacity and efficiency significantly reduced.

If the units are positioned in places surrounded by walls or obstacles of the same height as the units, the units should be at least 2500 mm from obstacles (Fig.3 and 4). In the event the obstacles are higher than the units, the units should be at least 3000 mm from the obstacle (Fig.5 and 6). Units installed closer than the minimum recommended distance to a wall or other vertical riser may experience a combination of coil starvation and warm air recirculation, thus causing reduction in unit capacity and efficiency reductions. The microprocessor control is proactive in response "of design condition". In the case of single or compounded influences restricting airflow to the unit, the microprocessor will act to keep the compressor running (at reduced capacity) rather than allowing a shut-off on high discharge pressure.

When two or more units are positioned side by side it is recommended that the condenser coils are at least 3600 mm distance from one another (Fig.7 and 8); strong wind could be the cause of air warm recirculation.

For other installation solutions, consult our technicians.

# 10 Installation notes

The above recommended information are representative for general installation. A specific evaluation should be done by contractor depending on the case.

Minimum recommended installation clearances.

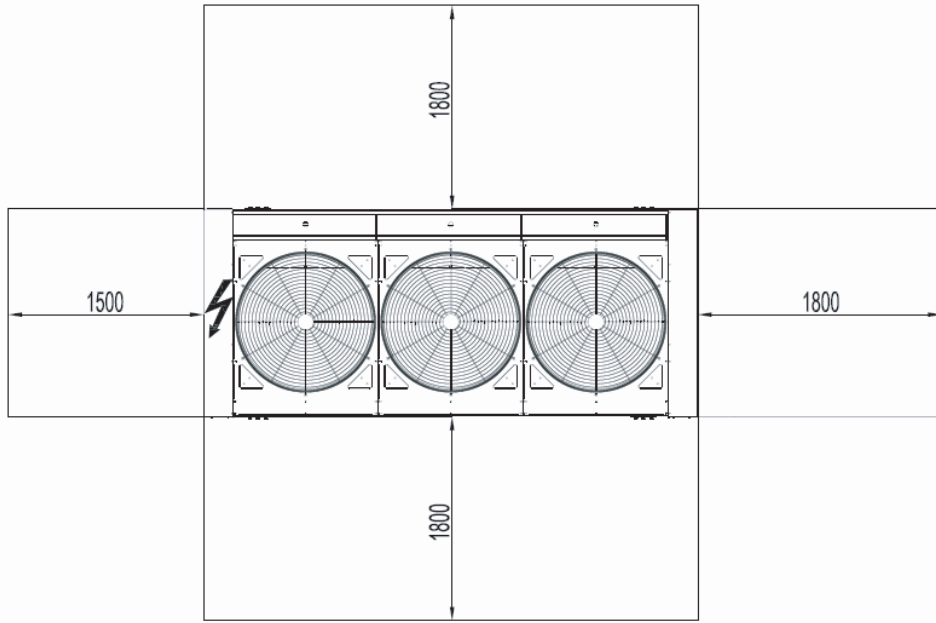

Fig. 1

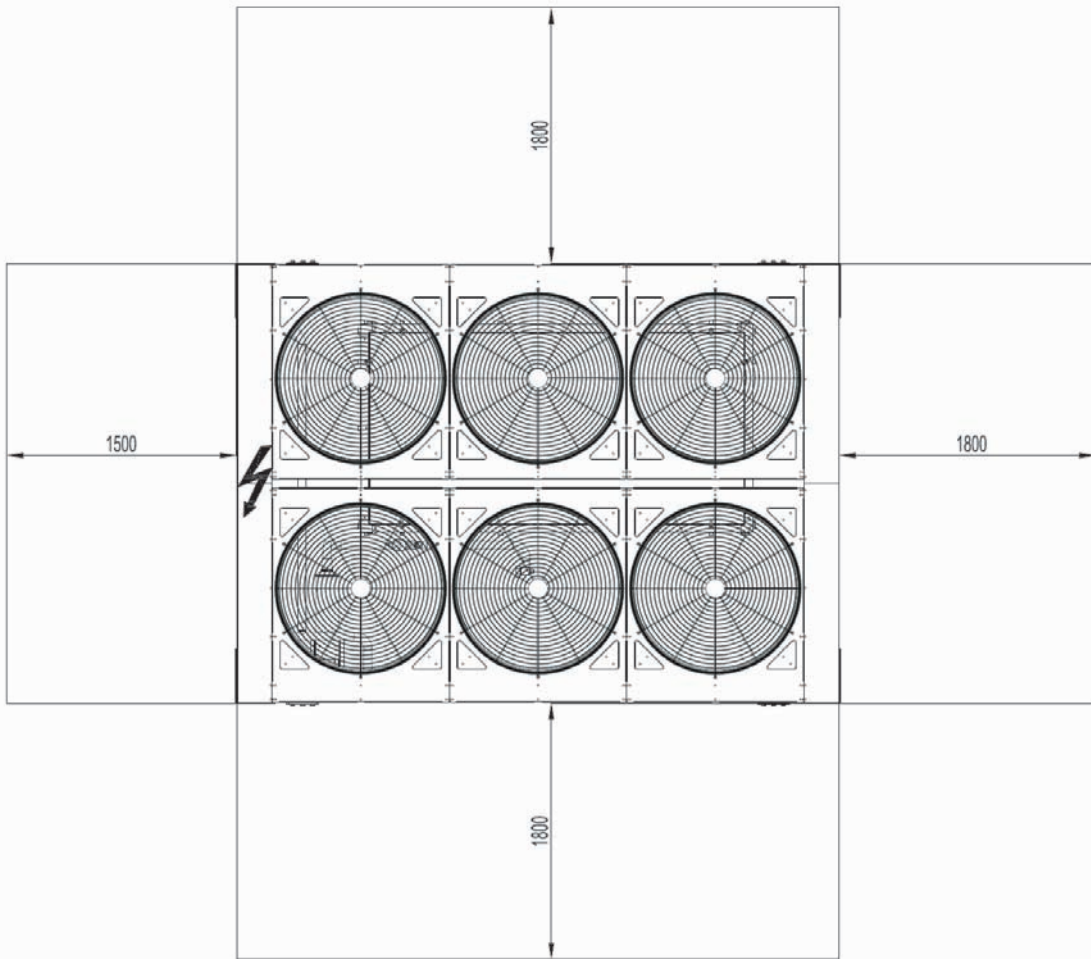

Fig. 2

# 10 Installation notes

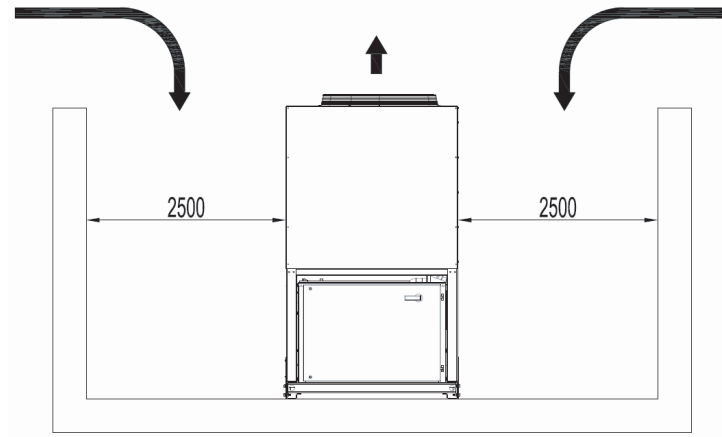

Fig. 3

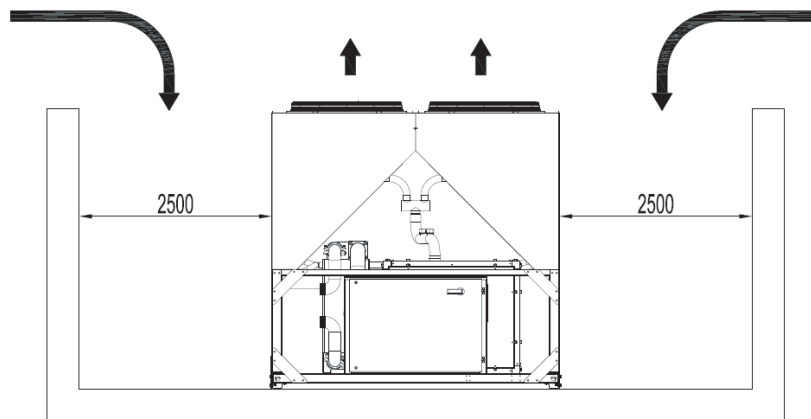

Fig. 4

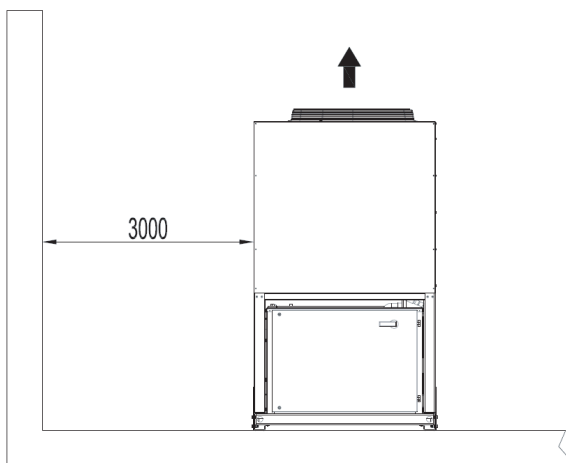

Fig. 5

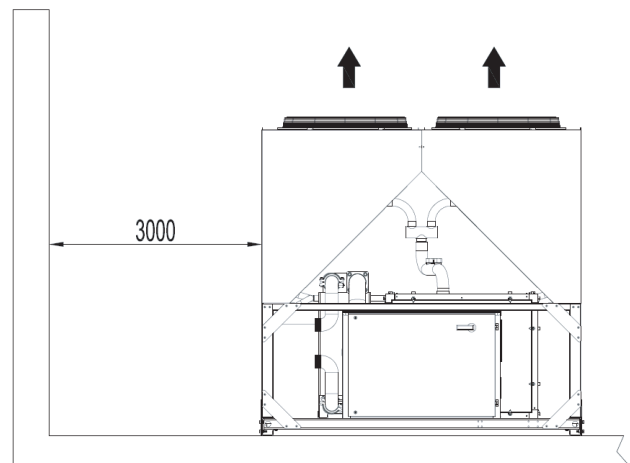

Fig. 6

## 10 Installation notes

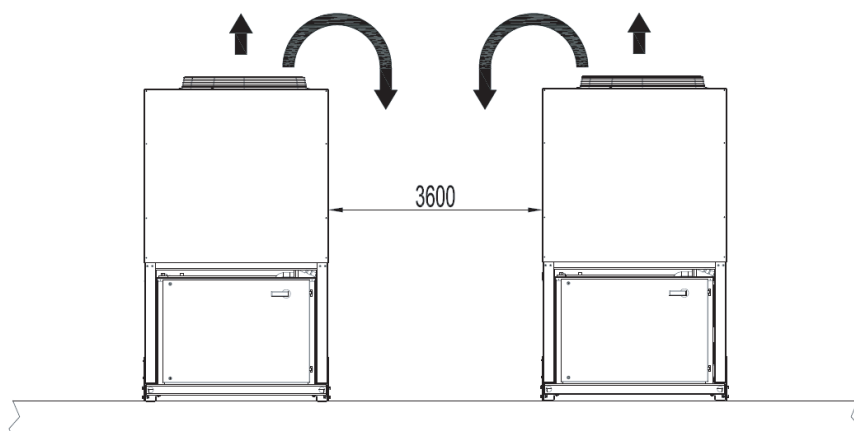

Fig. 7

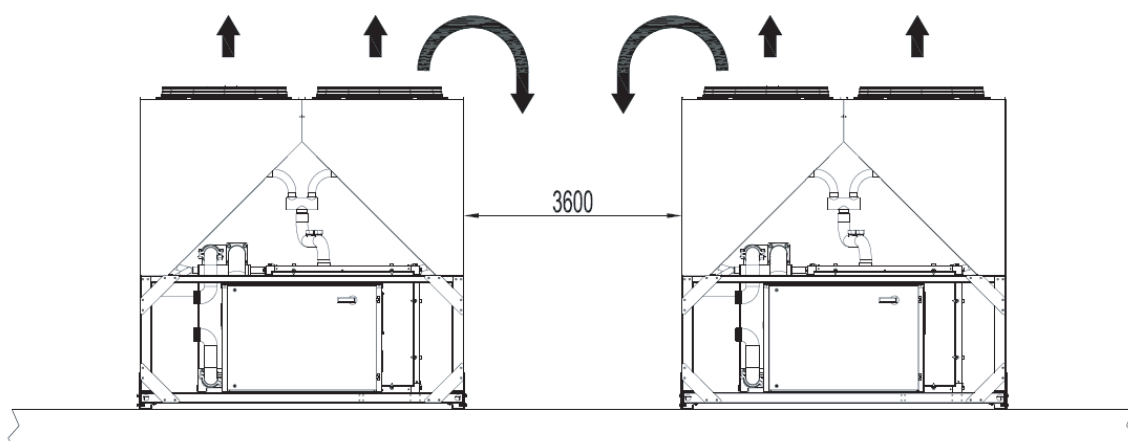

Fig. 8

### Acoustic protection

When sound level must meet special requirements, it is necessary to pay the maximum attention to ensure the perfect insulation of the unit from the support base by applying appropriate vibration-dampening devices on the unit, on the refrigerant pipes and on the electrical connections.

### Storage

The environment conditions have to be in the following limits:

Minimum ambient temperature:	-20°C
Maximum ambient temperature:	+57°C
Maximum R.H.:	95% not condensing

# 11 Specification

## Technical Specification for Air Cooled Condensing Unit

### GENERAL

The air cooled screw condensing unit will be designed and manufactured in accordance with following European directives:

Construction of pressure vessel	97/23/EC (PED)
Machinery Directive	2006/42/EC
Low Voltage	2006/95/EC
Electromagnetic Compatibility	2004/108/EC
Electrical & Safety codes	EN 60204-1 / EN 60335-2-40
Manufacturing Quality Stds	UNI – EN ISO 9001:2004

Before shipment a full test will be held to avoid any losses.

Condensing unit will be delivered to the job site completely assembled and charged with holding charge nitrogen 0.5 bar and with right oil quantity.

Comply with the manufacturer instructions for rigging and handling equipment.

The unit will be able to start up and operate as standard at full load and outside air temperature from .... °C to .... °C with an evaporator leaving fluid temperature between .... °C and ..... °C

### REFRIGERANT

Only R-134a will be accepted.

### PERFORMANCE

- ✓ Number of air cooled screw condensing unit: .....
- ✓ Cooling capacity for single air cooled screw condensing unit: ..... kW
- ✓ Power input for single air cooled screw condensing unit in cooling mode: ..... kW
- ✓ Nominal outside working ambient temperature in cooling mode: ..... °C
- ✓ Operating voltage range should be 400V ±10%, 3ph, 50Hz, voltage unbalance maximum 3%, without neutral conductor and shall only have one power connection point.

### UNIT DESCRIPTION

Condensing unit shall include as standard: one refrigerant circuit, semi-hermetic type rotary single screw compressor, air-cooled condenser section, R134a refrigerant, lubrication system, motor starting components, discharge line shut-off valve, suction line shut-off valve, control system and all components necessary for safe and stable unit operation.

Condensing unit will be factory assembled on a robust base-frame made of galvanized steel, protected by an epoxy paint.

### SOUND LEVEL AND VIBRATIONS

Sound pressure level at 1 meter distance in free field, semispheric conditions, shall not exceed .....dB(A). The sound pressure levels must be rated in accordance to ISO 3744.

Other types of rating unacceptable. Vibration on the base frame should not exceed 2 mm/s.

# 11 Specification

## DIMENSIONS

Unit dimensions shall not exceed following indications:

- ✓ unit length ..... mm,
- ✓ unit width ..... mm,
- ✓ unit height ..... mm.

## CONDENSING UNIT COMPONENTS

### Compressors

From size ERAD120E-SS to size ERAD250E-SS and from size ERAD120E-SL to size ERAD240E-SL

- ✓ Semi-hermetic, single-screw type with one main helical rotor meshing with gaterotor. The gaterotor will be constructed of a carbon impregnated engineered composite material. The gaterotor supports will be constructed of cast iron.

From size ERAD310E-SS to size ERAD 490E-SS and from size ERAD300E-SL to size ERAD460E-SL

- ✓ Semi-hermetic, single-screw asymmetric type with one main helical rotor meshing with two diametrical opposed gaterotors. The gaterotors' contact elements shall be constructed of composite material designed for extended life. Electrical motor shall be 2-pole, semi-hermetic, squirrel-cage induction type and cooled by suction gas.
- ✓ The oil injection shall be used in order to get high EER (Energy Efficiency Ratio) also at high condensing pressure and low sound pressure levels in each load condition.
- ✓ The compressor shall be provided with a built in, high efficiency, mesh type oil separator and oil filter.
- ✓ Refrigerant system differential pressure shall provide oil injection on all moving compressor parts to correctly lubricate them. Electrical oil pump lubricating system is not acceptable.
- ✓ Compressor cooling must be done by refrigerant liquid injection. External dedicated heat exchanger and additional piping to carry the oil from the compressor to heat exchanger and viceversa will be not accepted.
- ✓ The compressor shall be direct electrical driven, without gear transmission between the screw and the electrical motor.
- ✓ The compressor casing shall be provided with ports to realize economized refrigerant cycles.
- ✓ Compressor must be protected by temperature sensor for high discharge temperature and electrical motor thermistor for high winding temperature.
- ✓ The compressor shall be equipped with an electric oil heater.
- ✓ Compressor shall be fully field serviceable. Compressor that must be removed and returned to the factory for service shall be unacceptable.

### Cooling capacity control system

- ✓ Each condensing unit will have a microprocessor for the control of compressor slide valve position.
- ✓ The unit capacity control shall be infinitely modulating, from 100% down to 25%. The condensing unit shall be capable of stable operation to a minimum of 25% of full load without hot gas bypass.
- ✓ The system shall control the unit based on the leaving evaporator liquid or air temperature that shall be controlled by a PID (Proportional Integral Derivative) logic.
- ✓ Unit control logic shall manage the compressor slides to exactly match plant load request in order to keep constant the set point for delivered chilled liquid or air temperature.
- ✓ The microprocessor unit control shall detect conditions that approach protective limits and take self-corrective action prior to an alarm occurring. The system shall automatically reduce condensing unit capacity when any of the following parameters are outside their normal operating range:
  - o High condenser pressure
  - o Low evaporation refrigerant temperature



# 11 Specification

## Condenser coil

- ✓ The condenser coils are constructed with internally finned seamless copper tubes and arranged in a staggered row pattern and mechanically expanded into lanced and rippled aluminium fins with full fin collars for higher efficiencies. The space between the fins is given by a collar that will increase the surface area in connection with the tubes, protecting them from ambient corrosion.
- ✓ The coils will have an integral subcooler circuit that provides sufficient subcooling to effectively eliminate the possibility of liquid flashing and increase the unit's efficiency of 5-7% without increasing in energy consumption.
- ✓ The condenser coil shall be leak-tested and submitted to a pressure test with dry air.

## Condenser fans

- ✓ The fans used in conjunction with the condenser coils, shall be propeller type with glass reinforced resin blades for higher efficiencies and lower noise. Each fan shall be protected by a fan guard.
- ✓ The air discharge shall be vertical and each fan must be coupled to the electrical motor, supplied as standard to IP54 and capable to work to ambient temperatures of - 20°C to + 65°C.
- ✓ They shall have as a standard a thermally protection by internal thermal motor protection and protected by circuit breaker installed inside the electrical panel as a standard.

## Refrigerant circuit

- ✓ The circuit shall include as standard: compressor discharge shut-off valve, suction shut-off valve, replaceable core filter-drier, sight glass with moisture indicator and insulated suction line.

## Condensation control

- ✓ The units will be provided with an automatic control for condensing pressure which ensures the working at low external temperatures down to - 10 °C, to maintain condensing pressure.
- ✓ Compressor automatically unloads when abnormal high condensing pressure is detected to prevent the shutdown of the refrigerant circuit (shutdown of the unit) due to a high-pressure fault.

## Low Sound unit version (on request)

- ✓ The unit compressor shall be connected with unit's metal baseframe by rubber antivibration supports to prevent the transmission of vibrations to all metal unit structure and so to control the unit sound.
- ✓ The condensing unit shall be provided with an acoustically compressor enclosure. This enclosure shall be realized with a light, corrosion resisting aluminium structure and metal panels. The compressor sound-proof enclosure shall be internally fitted with flexible, multi layer, high density materials.

# 11 Specification

## Control panel

- ✓ Field power connection, control interlock terminals, and unit control system should be centrally located in an electric panel (IP 54). Power and starting controls should be separate from safety and operating controls in different compartments of the same panel.
- ✓ Compressor starting will be Wye-Delta type (Y-Δ).
- ✓ Operating and safety controls should include energy saving control; emergency stop switch; overload protection for compressor motor; high and low pressure cut-out switch (for each refrigerant circuit); anti-freeze thermostat; cut-out switch for the compressor.
- ✓ All of the information regarding the unit will be reported on a display and with the internal built-in calendar and clock that will switch the unit ON/OFF during day time all year long.
- ✓ The following features and functions shall be included:
  - leaving liquid or air temperature reset by controlling the liquid or air temperature  $\Delta t$ , by a remote 4-20mA DC signal or by controlling the external ambient temperature;
  - soft load function to prevent the system from operating at full load during the chilled fluid pulldown period;
  - password protection of critical parameters of control;
  - start-to-start and stop-to-start timers to provide minimum compressor off-time with maximum motor protection;
  - communication capability with a PC or remote monitoring;
  - discharge pressure control through intelligent cycling of condenser fans;
  - lead-lag selection by manual or automatically by circuit run hours;
  - double set point;
  - scheduling via internal time clock to allow programming of a yearly start-stop schedule accommodating weekends and holidays.

## Optional High Level Communications Interface

Condensing unit must be able to communicate to BMS (Building Management System) based on the most common protocols as:

- ModbusRTU
- LonWorks, now also based on the international 8040 Standard Condensing unit Profile and LonMark Technology
- BacNet BTP certified over IP and MS/TP (class 4) (Native)
- Ethernet TCP/IP.



Daikin's unique position as a manufacturer of air conditioning equipment, compressors and refrigerants has led to its close involvement in environmental issues. For several years Daikin has had the intention to become a leader in the provision of products that have limited impact on the environment. This challenge demands the eco design and development of a wide range of products and an energy management system, resulting in energy conservation and a reduction of waste.



The present publication is drawn up by way of information only and does not constitute an offer binding upon Daikin Europe N.V. Daikin Europe N.V. has compiled the content of this publication to the best of its knowledge. No express or implied warranty is given for the completeness, accuracy, reliability or fitness for particular purpose of its content and the products and services presented therein. Specifications are subject to change without prior notice. Daikin Europe N.V. explicitly rejects any liability for any direct or indirect damage, in the broadest sense, arising from or related to the use and/or interpretation of this publication. All content is copyrighted by Daikin Europe N.V.

Daikin products are distributed by:



Daikin Europe N.V. is participating in the EUROVENT Certification Programme. Products are as listed in the EUROVENT Directory of Certified Products.

