



Neola On-off SERIES

Service Manual 2012



MS11D-07HRN1 / MO11D-07HN1
MS11D-09HRN1 / MO11D-09HN1
MS11D-12HRN1 / MO11D-12HN1
MS11D-18HRN1 / MO11D-18HN1
MS11D-21HRN1 / MO11D-21HN1
MS11D-24HRN1 / MO11D-24HN1



CONTENTS

1. Precaution	3
1.1 Safety Precaution	3
1.2 Warning	3
2. Function	8
3. Specification	11
4. Dimension	15
4.1 Indoor Units	15
4.2 Outdoor Units	18
5. Capacity tables	19
6. Refrigerant Cycle Diagram	25
7. Wiring Diagram	26
7.1 Indoor Units	26
7.2 Outdoor Units	28
8. Installation details	30
8.1 Wrench torque sheet for installation	30
8.2 Connecting the cables	30
8.3 Pipe length and the elevation	31
8.4 Installation for the first time	31
8.5 Adding the refrigerant after running the system for many years	35
8.6 Re-installation while the indoor unit need to be repaired	36
8.7 Re-installation while the outdoor unit need to be repaired	38
9. Operation characteristics	41
10. Electronic function	42
10.1 Abbreviation	42
10.2 Display function.....	42
10.3 Main Protection	43
10.4 Operation Modes and Functions.....	43
11. Troubleshooting	51
11.1 Indoor unit error display	51
11.2 Diagnosis and Solution	52

1. Precaution

1.1 Safety Precaution

■ **To prevent injury to the user or other people and property damage, the following instructions must be followed.**

- **Incorrect operation due to ignoring instruction will cause harm or damage.**
- **Before service unit, be sure to read this service manual at first.**

1.2 Warning

➤ Installation

■ **Do not use a defective or underrated circuit breaker. Use this appliance on a dedicated circuit.**

There is risk of fire or electric shock.

■ **For electrical work, contact the dealer, seller, a qualified electrician, or an Authorized service center.**

Do not disassemble or repair the product, there is risk of fire or electric shock.

■ **Always ground the product.**

There is risk of fire or electric shock.

■ **Install the panel and the cover of control box securely.**

There is risk of fire of electric shock.

■ **Always install a dedicated circuit and breaker.**

Improper wiring or installation may cause fire or electric shock.

■ **Use the correctly rated breaker or fuse.**

There is risk of fire or electric shock.

■ **Do not modify or extend the power cable.**

There is risk of fire or electric shock.

■ **Do not install, remove, or reinstall the unit by yourself(customer).**

There is risk of fire, electric shock, explosion, or injury.

■ **Be caution when unpacking and installing the product.**

Sharp edges could cause injury, be especially careful of the case edges and the fins on the condenser and evaporator.

- **For installation, always contact the dealer or an Authorized service center.**

There is risk of fire, electric shock, explosion, or injury.

- **Do not install the product on a defective installation stand.**

It may cause injury, accident, or damage to the product.

- **Be sure the installation area does not deteriorate with age.**

If the base collapses, the air conditioner could fall with it, causing property damage, product failure, and personal injury.

- **Do not let the air conditioner run for a long time when the humidity is very high and a door or a window is left open.**

Moisture may condense and wet or damage furniture.

- **Take care to ensure that power cable could not be pulled out or damaged during operation.**

There is risk of fire or electric shock.

- **Do not place anything on the power cable.**

There is risk of fire or electric shock.

- **Do not plug or unplug the power supply plug during operation.**

There is risk of fire or electric shock.

- **Do not touch (operation) the product with wet hands.**

There is risk of fire or electric shock.

- **Do not place a heater or other appliance near the power cable.**

There is risk of fire and electric shock.

- **Do not allow water to run into electric parts.**

It may cause fire, failure of the product, or electric shock.

- **Do not store or use flammable gas or combustible near the product.**

There is risk of fire or failure of product.

- **Do not use the product in a tightly closed space for a long time.**

Oxygen deficiency could occur.

- **When flammable gas leaks, turn off the gas and open a window for ventilation before turn the product on.**

Do not use the telephone or turn switches on or off.

There is risk of explosion or fire.

- **If strange sounds, or small or smoke comes from product. Turn the breaker off or disconnect the power supply cable.**

There is risk of electric shock or fire.

- **Stop operation and close the window in storm or hurricane. If possible, remove the product from the window before the hurricane arrives.**

There is risk of property damage, failure of product, or electric shock.

- **Do not open the inlet grill of the product during operation. (Do not touch the electrostatic filter, if the unit is so equipped.)**

There is risk of physical injury, electric shock, or product failure.

- **When the product is soaked (flooded or submerged), contact an Authorized service center.**

There is risk of fire or electric shock.

- **Be caution that water could not enter the product.**

There is risk of fire, electric shock, or product damage.

- **Ventilate the product from time to time when operating it together with a stove, etc.**

There is risk of fire or electric shock.

- **Turn the main power off when cleaning or maintaining the product.**

There is risk of electric shock.

- **When the product is not be used for a long time, disconnect the power supply plug or turn off the breaker.**

There is risk of product damage or failure, or unintended operation.

- **Take care to ensure that nobody could step on or fall onto the outdoor unit.**

This could result in personal injury and product damage.

➤ CAUTION

- **Always check for gas (refrigerant) leakage after installation or repair of product.**

Low refrigerant levels may cause failure of product.

- **Install the drain hose to ensure that water is drained away properly.**

A bad connection may cause water leakage.

- **Keep level even when installing the product.**

It can avoid vibration of water leakage.

- **Do not install the product where the noise or hot air from the outdoor unit could damage the neighborhoods.**

It may cause a problem for your neighbors.

- **Use two or more people to lift and transport the product.**

Avoid personal injury.

- **Do not install the product where it will be exposed to sea wind (salt spray) directly.**

It may cause corrosion on the product. Corrosion, particularly on the condenser and evaporator fins, could cause product malfunction or inefficient operation.

➤ **Operational**

- **Do not expose the skin directly to cool air for long periods of time. (Do not sit in the draft).**

This could harm to your health.

- **Do not use the product for special purposes, such as preserving foods, works of art, etc.**

It is a consumer air conditioner, not a precision refrigerant system.

There is risk of damage or loss of property.

- **Do not block the inlet or outlet of air flow.**

It may cause product failure.

- **Use a soft cloth to clean. Do not use harsh detergents, solvents, etc.**

There is risk of fire, electric shock, or damage to the plastic parts of the product.

- **Do not touch the metal parts of the product when removing the air filter. They are very sharp.**

There is risk of personal injury.

- **Do not step on or put anything on the product. (outdoor units)**

There is risk of personal injury and failure of product.

- **Always insert the filter securely. Clean the filter every two weeks or more often if necessary.**

A dirty filter reduces the efficiency of the air conditioner and could cause product malfunction or damage.

- **Do not insert hands or other object through air inlet or outlet while the product is operated.**

There are sharp and moving parts that could cause personal injury.

- **Do not drink the water drained from the product.**

It is not sanitary could cause serious health issues.

- **Use a firm stool or ladder when cleaning or maintaining the product.**

Be careful and avoid personal injury.

- **Replace the all batteries in the remote control with new ones of the same type. Do not mix old and new batteries or different types of batteries.**

There is risk of fire or explosion.

- **Do not recharge or disassemble the batteries. Do not dispose of batteries in a fire.**

They may burn or explode.

- **If the liquid from the batteries gets onto your skin or clothes, wash it well with clean water. Do not use the remote if the batteries have leaked.**

The chemical in batteries could cause burns or other health hazards

2. Function

Model Names of Indoor/Outdoor Units

Series	Capacity	Indoor units
On-Off	7K Btu	MS11D-07HRN1
		MO11D-07HN1
	9K Btu	MS11D-09HRN1
		MO11D-09HN1
	12K Btu	MS11D-12HRN1
		MO11D-12HN1
	18K Btu	MS11D-18HRN1
		MO11D-18HN1
	21K Btu	MS11D-21HRN1
		MO11D-21HN1
	24K Btu	MS11D-24HRN1
		MO11D-24HN1

The designs, and information in this book are subject to change without notice for product improvement.

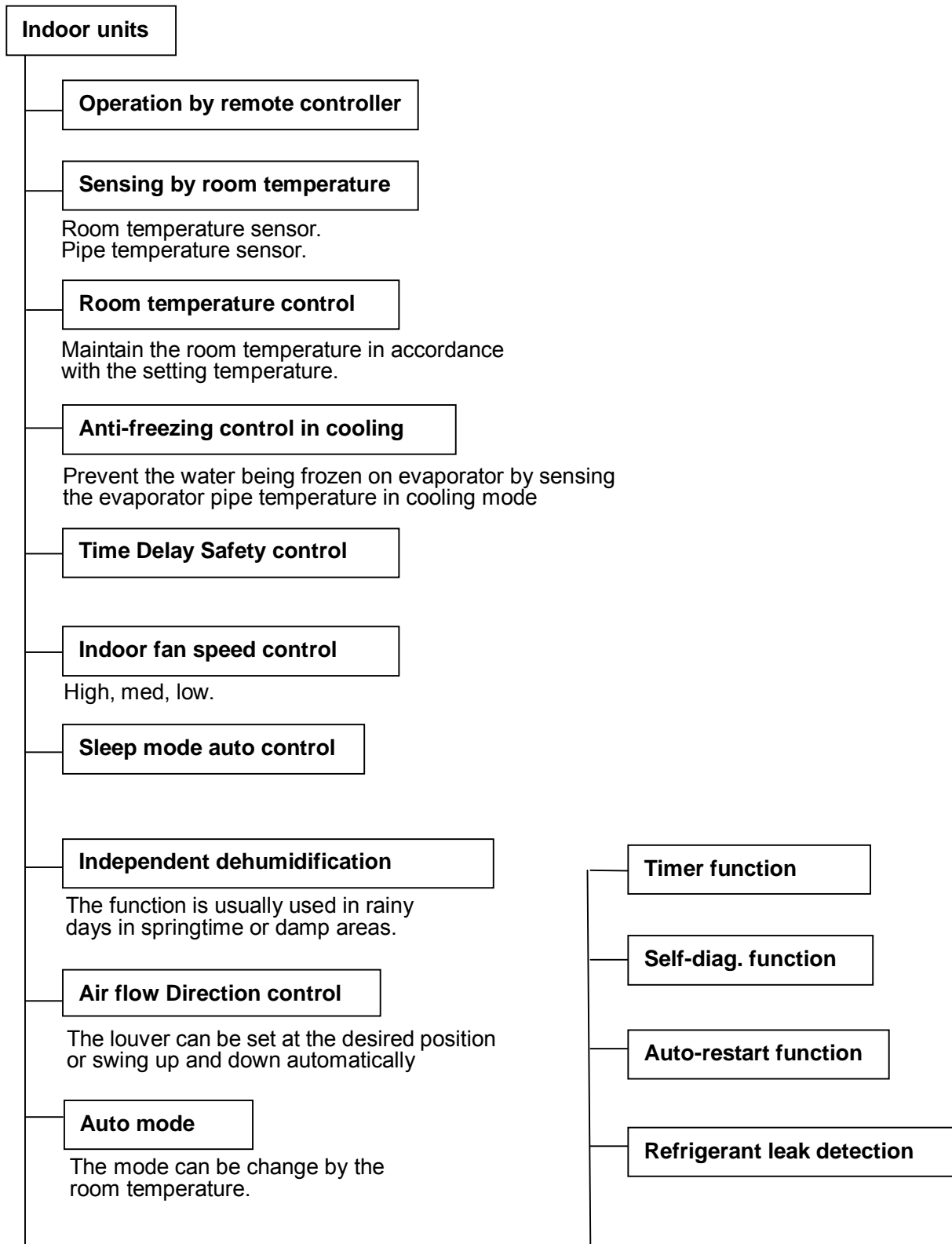

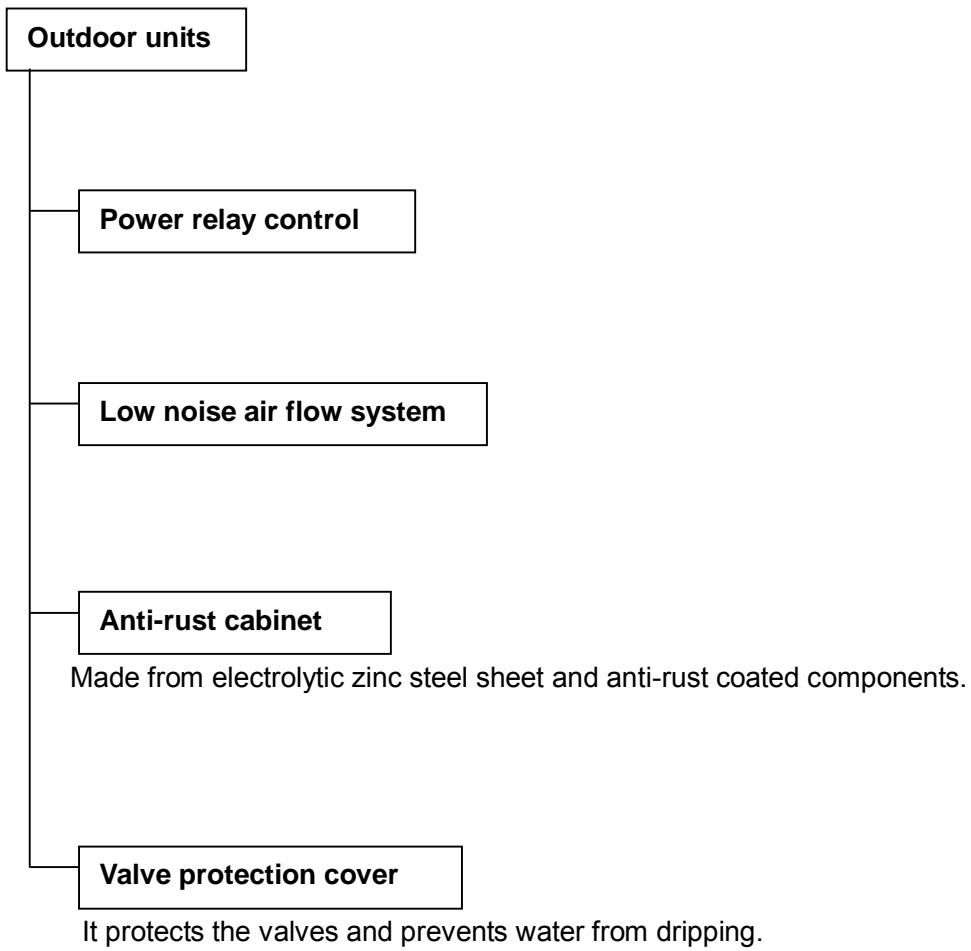

3. Specification

Indoor model name			MS11D-07HRN1	MS11D-09HRN1	MS11D-12HRN1
Outdoor model name			MO11D-07HN1	MO11D-09HN1	MO11D-12HN1
Power supply		Ph-V-Hz	220-240V~ 50Hz, 1Ph	220-240V~ 50Hz, 1Ph	220-240V~ 50Hz, 1Ph
Cooling	Capacity	Btu/h	7000	9000	12000
		kW	2,05	2,64	3,52
	Input	W	785	1005	1347
	Rated current	A	3.4	4.3	6.1
	EER	W/W	2.61	2.62	2.61
Heating	Capacity	Btu/h	7000	9000	12000
		kW	2,05	2,64	3,52
	Input	W	640	876	1096
	Rated current	A	2.8	3.8	5.0
	COP	W/W	3.21	3.01	3.21
Moisture Removal		L/h	0.8	1.0	1.2
Max. input consumption		W	1080	1655	1912
Max. current		A	5.0	7.2	8.5
Starting current		A	15	19.2	22.2
Compressor	Model		PA82X1C-4DZDE	PA108M1C-4DZDE2	PA130G1C-4DZ
	Type		ROTARY	ROTARY	ROTARY
	Brand		GMCC	GMCC	GMCC
	Capacity	Btu/h	6551/6653	8769/8769	10611/10747
	Input	W	660/680	860/905	1055/1105
	Rated current(RLA)	A	3.04/2.85	4.00/4.00	4.86/4.79
	Locked rotor Amp(LRA)	A	15	19.2	22.2
	Thermal protector		B135-135-241E / MRA13408-9087	B160-135-241E	----
	Thermal protector position		EXTERNAL	EXTERNAL	INTERNAL
	Capacitor	uF	25	25	35
	Refrigerant oil/oil charge	ml	ESTER OIL VG74 / 350	ESTER OIL VG74/350	ESTER OIL VG74/400
Indoor fan motor	Model		RPG13H	RPG13H	RPG20D
	Brand		Welling	Welling	Welling
	Input	W	34	34	43.3
	Capacitor	uF	1.2	1.2	1.5
	Speed(Hi/Mi/Lo)	r/min	1200/950/800	1220/1000/800	1250/1050/800
Indoor coil	a.Number of rows		1/2	1/2	1/2
	b.Tube pitch(a)x row pitch(b)	mm	20x11.28	20x11.28	21x13.37
	c.Fin spacing	mm	1.3/1.4	1.3/1.4	1.2/1.3
	d. Fin type (code)		Hydrophilic aluminum	Hydrophilic aluminum	Hydrophilic aluminum
	e. Tube outside dia. and type	mm	6,innergroove tube	6,innergroove tube	7,innergroove tube
	f. Coil length x height x width	mm	510x80x11.28 +510x180x22.56	510x80x11.28 +510x180x22.56	600x84x13.37 +600x189x26.74
	g.Number of circuits		2	2	2
Indoor air flow (Hi/Mi/Lo)		m3/h	480/380/320	470/390/310	600/510/370

Indoor noise level (Hi/Mi/Lo)		dB(A)	40/34/29	40/37/30	40/35/30
Indoor unit	Dimension(W*D*H)	mm	680x255x178	680x255x178	770x255x188
	Packing (W*D*H)	mm	745x255x330	745x255x330	835x265x330
	Net/Gross weight	Kg	7 / 8.5	7 / 8.5	7.5/9.0
Outdoor fan motor	Model		YDK25-4(B)	YDK25-4(B)	YDK24-6(B)
	Brand		Welling	Welling	Welling
	Input	W	61	61	77.3
	Capacitor	uF	2.0	2	2.5
	Speed	r/min	965 / -- / --	965 / -- / --	860 / -- / --
Outdoor coil	a.Number of rows		1	1	1
	b.Tube pitch(a)x row pitch(b)	mm	21x13.37	21x13.37	21x13.37
	c.Fin spacing	mm	1.3	1.3	1.4
	d.Fin type (code)		Hydrophilic aluminum	Hydrophilic aluminum	Hydrophilic aluminum
	e.Tube outside dia.and type	mm	7,innergroove tube	7,innergroove tube	7,innergroove tube
	f.Coil length x height x width	mm	502*399*13.37	676x399x13.37	598x504x13.37
	g.Number of circuits		2	2	2
Outdoor air flow		m3/h	1300	1300	1900
Outdoor noise level		dB(A)	54	56	56
Outdoor unit	Dimension(W*D*H)	mm	685x260x430	685x260x430	700x240x540
	Packing (W*D*H)	mm	795x345x495	795x345x495	815x325x580
	Net/Gross weight	Kg	23 / 25	23 / 25	24.5 / 26.5
Refrigerant type		g	R410A/510g	R410A/560g	R410A/630g
Design pressure		MPa	4.2/1.5	4.2/1.5	4.2/1.5
Refrigerant piping	Liquid side/ Gas side	mm(inc h)	6.35/ 9.52(1/4"/3/8")	6.35/ 9.52(1/4"/3/8")	6.35/ 12.7(1/4"/1/2")
	Max. refrigerant pipe length	m	20	20	20
	Max. difference in level	m	8	8	8
Connection wiring			1.5(Optional)	1.5(Optional)	1.5(Optional)
Plug type			1.5 / VDE	1.5 / VDE	1.5 / VDE
Thermostat type			Remote Control	Remote Control	Remote Control
Operation temp		℃	17-30	17-30	17-30
Ambient temp (cooling/heating)		℃	18-43/-7-24	18-43/-7-24	18-43/-7-24
Application area		m2	10-17	13-22	16-27

Indoor model name			MS11D-18HRN1	MS11D-21HRN1	MS11D-24HRN1
Outdoor model name			MO11D-18HN1	MO11D-21HN1	MO11D-24HN1
Power supply		Ph-V-Hz	220-240V~ 50Hz, 1Ph	220-240V~ 50Hz, 1Ph	220-240V~ 50Hz, 1Ph
Cooling	Capacity	Btu/h	18000	21000	24000
		kW	5,28	6,15	7,03
	Input	W	2020	2358	2695
	Rated current	A	8.1	10.6	12
	EER	W/W	2.61	2.61	2.61
Heating	Capacity	Btu/h	18500	23000	25000
		kW	5,42	6,74	7,33
	Input	W	1690	2240	2425
	Rated current	A	7.7	10.1	10.8
	COP	W/W	3.21	3.01	3.02
Moisture Removal		L/h	1.8	2.2	2.6
Max. input consumption		W	2324	3380	3750
Max. current		A	11.9	16.5	19.0
Starting current		A	25.9	29.9	36.8
Compressor	Model		PA185M2C-4FT2	PA215M2CS-4KU	PA240M2CS-4KU1
	Type		ROTARY	ROTARY	ROTARY
	Brand		GMCC	GMCC	GMCC
	Capacity	Btu/h	15712/15848	18015/18152	20028/20335
	Input	W	1490/1515	1790/1870	1985/2055
	Rated current(RLA)	A	6.90/6.50	8.3/8.2	9.3/9.1
	Locked rotor Amp(LRA)	A	25.9	29.9	36.8
	Thermal protector		----	----	----
	Thermal protector position		INTERNAL	INTERNAL	INTERNAL
	Capacitor	uF	35	50	50
	Refrigerant oil/oil charge	ml	ESTER OIL VG74 480cc	ESTER OIL VG74/750	ESTER OIL VG74 750cc
Indoor fan motor	Model		RPG25	RPG45C	RPG45C
	Brand		Welling	Broad Ocean	Broad Ocean
	Input	W	55	72	72
	Capacitor	uF	1.5	3.0	3.0
	Speed(Hi/Mi/Lo)	r/min	1280/1100/800	1250/1100/900	1220 / 1100 / 900
Indoor coil	a.Number of rows		1/2	2	2
	b.Tube pitch(a)x row pitch(b)	mm	21x13.37	21x13.37	21x13.37
	c.Fin spacing	mm	1.2/1.3	1.3	1.3
	d.Fin type (code)		Hydrophilic aluminum	Hydrophilic aluminum	Hydrophilic aluminum
	e.Tube outside dia.and type	mm	7,innergroove tube	7,innergroove tube	7,innergroove tube
	f.Coil length x height x width	mm	720x84x13.37+720x210x26.7 4	780x315x26.74	780x315x26.74
	g.Number of circuits		4	5	5
Indoor air flow (Hi/Mi/Lo)		m3/h	780/670/500	1100/950/800	1100/1000/910

Indoor noise level (Hi/Mi/Lo)		dB(A)	44/40/35	48/44/38	48/45/39
Indoor unit	Dimension(W*D*H)	mm	905x275x198	1030x315x218	1030x315x218
	Packing (W*D*H)	mm	970x270x345	1115x395x300	1115x395x300
	Net/Gross weight	Kg	9.8/11.7	12 / 15	12 / 15
Outdoor fan motor	Model		YDK24-6(B)	YDK48-6H(A)	YDK100-6D(B)
	Brand		Welling	Welling	Welling
	Input	W	77.3	110	177
	Capacitor	uF	2.5	3.0	5.0
	Speed	r/min	860 / -- / --	890 / -- / --	875 / -- / --
Outdoor coil	a.Number of rows		1.6	2	2
	b.Tube pitch(a)x row pitch(b)	mm	21x13.37	21x13.37	21x13.37
	c.Fin spacing	mm	1.5	1.4	1.4
	d.Fin type (code)		Hydrophilic aluminum	Hydrophilic aluminum	Hydrophilic aluminum
	e.Tube outside dia.and type	mm	7,innergroove tube	7,innergroove tube	7,innergroove tube
	f.Coil length x height x width	mm	(769+474) x504x13.37	653x546x26.74	760*546*26.74
	g.Number of circuits		4	4	4
Outdoor air flow		m3/h	2000	2400	2500
Outdoor noise level		dB(A)	58	60	62
Outdoor unit	Dimension(W*D*H)	mm	780x250x540	760x285x590	820x330x595
	Packing (W*D*H)	mm	910x335x585	887x355x645	940x415x645
	Net/Gross weight	Kg	32.1/34.2	37.5 / 40	43.5 / 46.5
Refrigerant type		g	R410A/1130g	R410A/1400g	R410A/1600g
Design pressure		MPa	4.2/1.5	4.2/1.5	4.2/1.5
Refrigerant piping	Liquid side/ Gas side	mm(inch)	6.35/ 12.7(1/4"/1/2")	9.52/ 16(3/8"/5/8")	9.52/ 16(3/8"/5/8")
	Max. refrigerant pipe length	m	20	25	25
	Max. difference in level	m	8	10	10
Connection wiring			2.5(Optional)	1.0(Optional)	1.0(Optional)
Plug type			14#	2.5	2.5
Thermostat type			Remote Control	Remote Control	Remote Control
Operation temp		℃	17-30	17-30	17-30
Ambient temp (cooling/heating)		℃	18-43/-7-24	18-43/-7-24	18-43/-7-24
Application area		m2	23-39	29-48	32-53

4. Dimension

4.1 Indoor Units

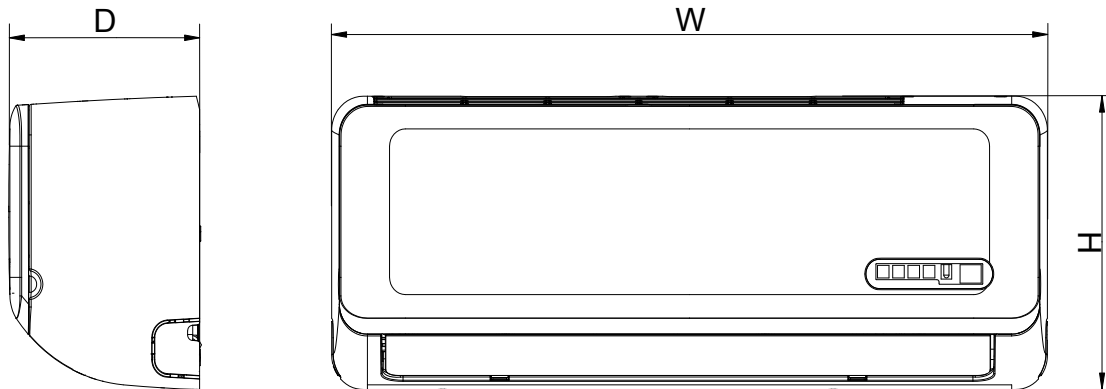

Model	W	D	H
MS11D-07HRN1	680	178	255
MS11D-09HRN1	680	178	255
MS11D-12HRN1	770	188	255
MS11D-18HRN1	905	198	275
MS11D-21HRN1	1030	218	315
MS11D-24HRN1	1030	218	315

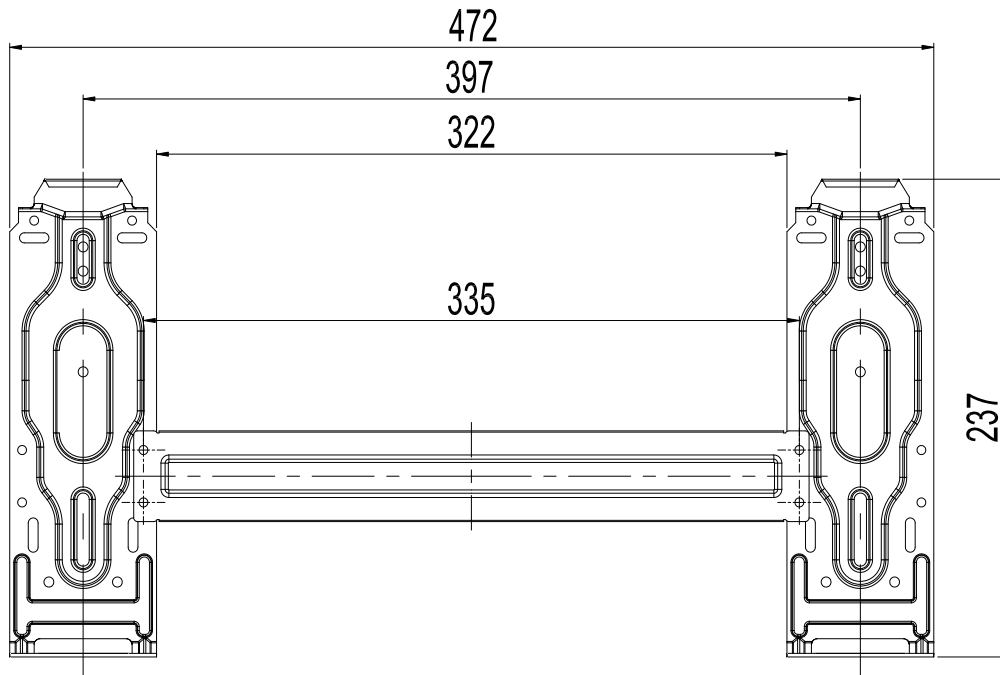

7k, 9k

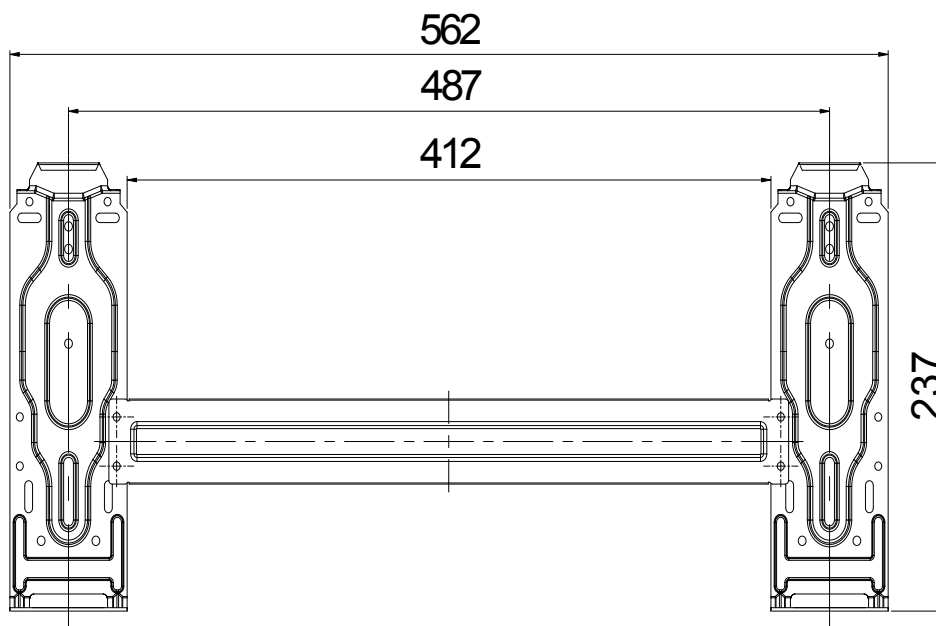

12k

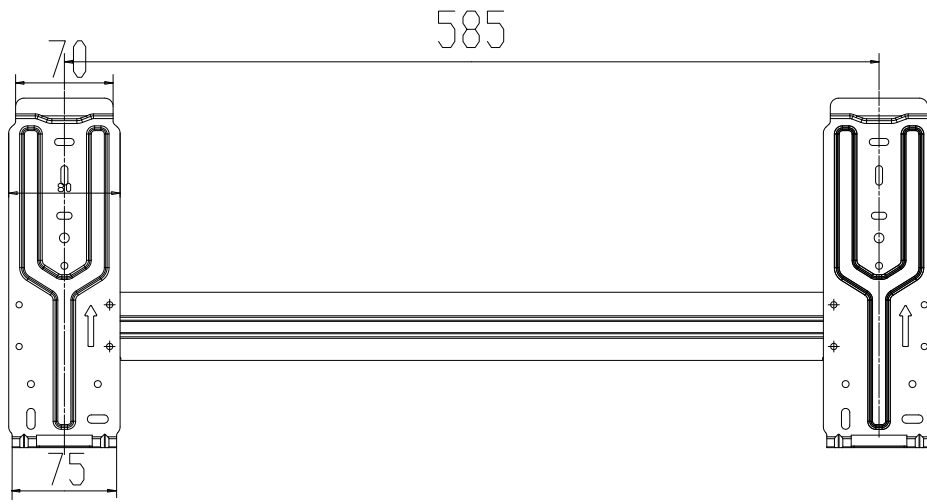

18k

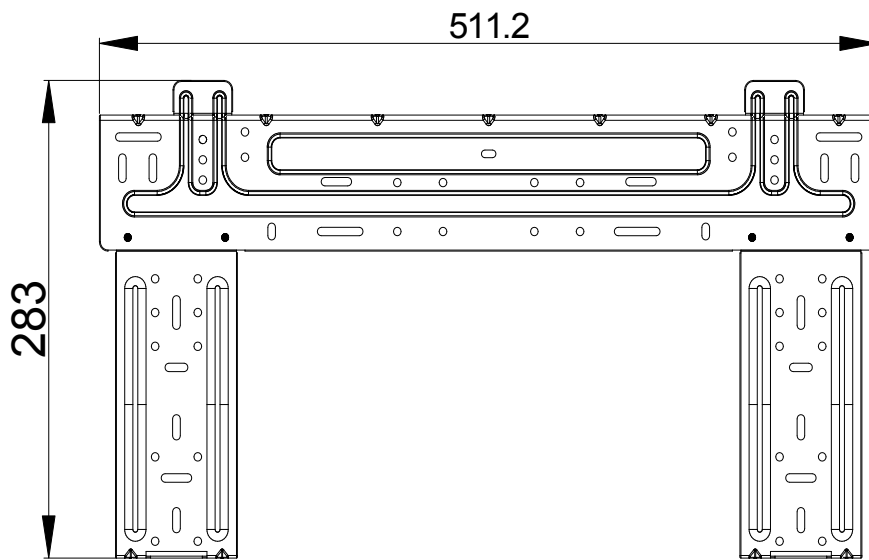

21K, 24K

4.2 Outdoor Units

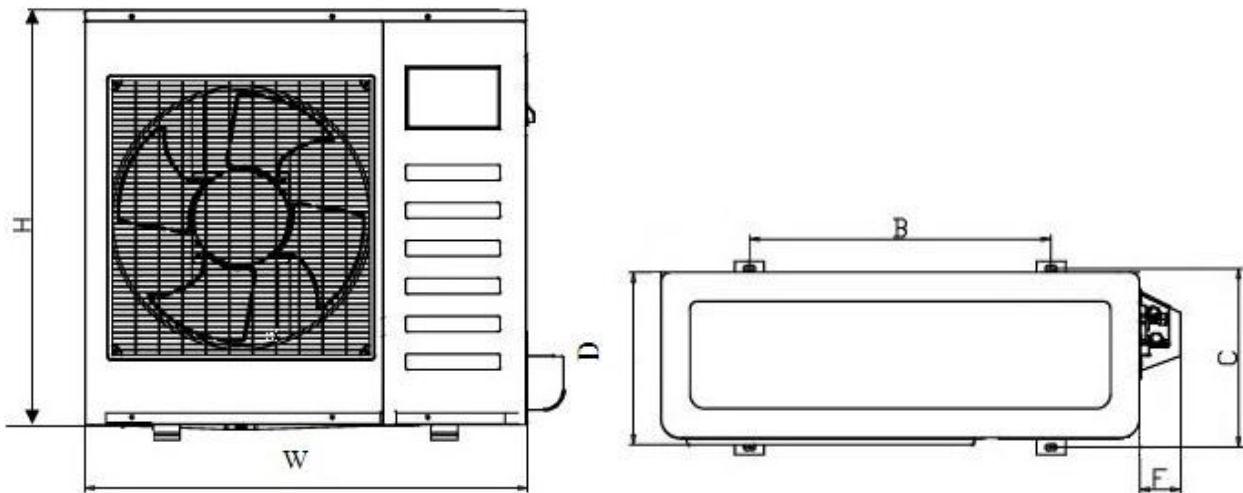
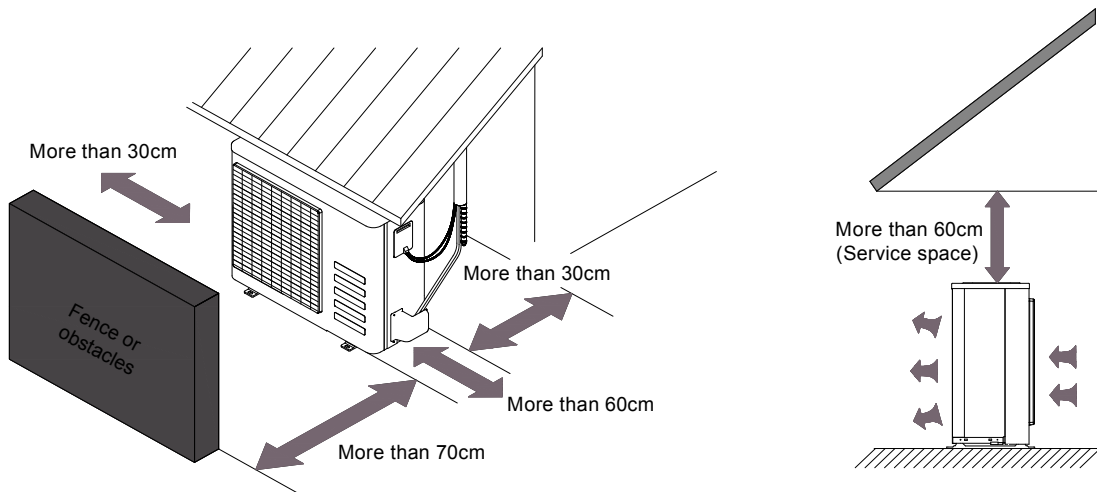

Model	W	H	D	B	C	F
MO11D-07HN1	685	260	430	742	460	276
MO11D-09HN1	685	260	430	742	460	276
MO11D-12HN1	700	240	540	757	458	250
MO11D-18HN1	780	250	540	843	549	276
MO11D-21HN1	760	285	590	823	530	290
MO11D-24HN1	820	330	595	870	523	340

5. Capacity tables

MS11D-07HRN1 / MO11D-07HN1

Cooling

Cooling		Outdoor conditions (DB)				
Indoor Conditions	(kW)	18°C	21°C	28°C	35°C	43°C
21/15°C DB/WB	TC	2.21	2.11	2.01	1.91	1.82
	SC	1.59	1.56	1.55	1.53	1.53
	Input	2.09	2.17	2.35	2.45	2.53
24/17°C DB/WB	TC	2.26	2.17	2.07	1.97	1.85
	SC	1.65	1.63	1.61	1.59	1.55
	Input	2.11	2.30	2.45	2.56	2.69
27/19°C DB/WB	TC	2.30	2.21	2.11	2.05	1.91
	SC	1.65	1.64	1.63	1.60	1.56
	Input	2.19	2.35	2.48	2.61	2.74
32/23°C DB/WB	TC	2.34	2.26	2.17	2.13	1.97
	SC	1.94	1.92	1.89	1.88	1.83
	Input	2.35	2.45	2.56	2.74	2.84

Heating

Heating		Outdoor conditions				
Indoor Conditions (DB)	(kW)	24/18°C DB/WB	7/6°C DB/WB	2/1°C DB/WB	-5/-6°C DB/WB	-7/-8°C DB/WB
15°C	TC	2.67	2.15	1.76	1.60	1.50
	Input	3.47	2.99	2.57	2.41	2.28
20°C	TC	2.58	2.05	1.66	1.56	1.44
	Input	3.79	3.21	2.82	2.60	2.44
27°C	TC	2.42	1.93	1.56	1.52	1.35
	Input	4.01	3.47	3.05	2.82	2.63

Remark:

TC : Total capacity ; kW

SC: Sensible heat capacity ; kW

Input: Input power ; kW

MS11D-09HRN1 / MO11D-09HN1

Cooling

Cooling		Outdoor conditions (DB)				
Indoor Conditions	(kW)	18°C	21°C	28°C	35°C	43°C
21/15°C DB/WB	TC	2.85	2.72	2.59	2.46	2.35
	SC	2.05	2.01	1.99	1.96	1.97
	Input	2.10	2.17	2.36	2.46	2.54
24/17°C DB/WB	TC	2.90	2.80	2.67	2.53	2.38
	SC	2.12	2.10	2.08	2.05	2.00
	Input	2.12	2.31	2.46	2.57	2.70
27/19°C DB/WB	TC	2.96	2.85	2.72	2.64	2.46
	SC	2.13	2.11	2.09	2.06	2.01
	Input	2.20	2.36	2.49	2.62	2.75
32/23°C DB/WB	TC	3.01	2.90	2.80	2.75	2.53
	SC	2.50	2.47	2.43	2.42	2.36
	Input	2.36	2.46	2.57	2.75	2.86

Heating

Heating		Outdoor conditions				
Indoor Conditions (DB)	(kW)	24/18°C DB/WB	7/6°C DB/WB	2/1°C DB/WB	-5/-6°C DB/WB	-7/-8°C DB/WB
15°C	TC	3.43	2.77	2.27	2.06	1.93
	Input	3.25	2.80	2.41	2.26	2.14
20°C	TC	3.33	2.64	2.14	2.01	1.85
	Input	3.55	3.01	2.65	2.44	2.29
27°C	TC	3.12	2.48	2.01	1.95	1.74
	Input	3.76	3.25	2.86	2.65	2.47

Remark:

TC : Total capacity ; kW

SC: Sensible heat capacity ; kW

Input: Input power ; kW

MS11D-12HRN1 / MO11D-12HN1**Cooling**

Cooling		Outdoor conditions (DB)				
Indoor Conditions	(kW)	18°C	21°C	28°C	35°C	43°C
21/15°C DB/WB	TC	3.80	3.63	3.45	3.27	3.13
	SC	2.74	2.68	2.66	2.62	2.63
	Input	2.09	2.17	2.35	2.45	2.53
24/17°C DB/WB	TC	3.87	3.73	3.56	3.38	3.17
	SC	2.83	2.80	2.77	2.74	2.66
	Input	2.11	2.30	2.45	2.56	2.69
27/19°C DB/WB	TC	3.94	3.80	3.63	3.52	3.27
	SC	2.84	2.81	2.79	2.75	2.68
	Input	2.19	2.35	2.48	2.61	2.74
32/23°C DB/WB	TC	4.01	3.87	3.73	3.66	3.38
	SC	3.33	3.29	3.25	3.22	3.14
	Input	2.35	2.45	2.56	2.74	2.84

Heating

Heating		Outdoor conditions				
Indoor Conditions (DB)	(kW)	24/18°C DB/WB	7/6°C DB/WB	2/1°C DB/WB	-5/-6°C DB/WB	-7/-8°C DB/WB
15°C	TC	4.58	3.70	3.03	2.75	2.57
	Input	3.47	2.99	2.57	2.41	2.28
20°C	TC	4.44	3.52	2.85	2.68	2.46
	Input	3.79	3.21	2.82	2.60	2.44
27°C	TC	4.15	3.31	2.68	2.60	2.32
	Input	4.01	3.47	3.05	2.82	2.63

Remark:

TC : Total capacity ; kW

SC: Sensible heat capacity ; kW

Input: Input power ; kW

MS11D-18HRN1 / MO11D-18HN1

Cooling

Cooling		Outdoor conditions (DB)				
Indoor Conditions	(kW)	18°C	21°C	28°C	35°C	43°C
21/15°C DB/WB	TC	5.70	5.44	5.17	4.91	4.70
	SC	4.11	4.02	3.98	3.93	3.95
	Input	2.09	2.17	2.35	2.45	2.53
24/17°C DB/WB	TC	5.81	5.60	5.33	5.07	4.75
	SC	4.24	4.20	4.16	4.11	3.99
	Input	2.11	2.30	2.45	2.56	2.69
27/19°C DB/WB	TC	5.91	5.70	5.44	5.28	4.91
	SC	4.26	4.22	4.19	4.12	4.03
	Input	2.19	2.35	2.48	2.61	2.74
32/23°C DB/WB	TC	6.02	5.81	5.60	5.49	5.07
	SC	5.00	4.94	4.87	4.83	4.71
	Input	2.35	2.45	2.56	2.74	2.84

Heating

Heating		Outdoor conditions				
Indoor Conditions (DB)	(kW)	24/18°C DB/WB	7/6°C DB/WB	2/1°C DB/WB	-5/-6°C DB/WB	-7/-8°C DB/WB
15°C	TC	7.05	5.69	4.66	4.23	3.96
	Input	3.47	2.99	2.57	2.41	2.28
20°C	TC	6.83	5.42	4.39	4.12	3.79
	Input	3.79	3.21	2.82	2.60	2.44
27°C	TC	6.40	5.09	4.12	4.01	3.58
	Input	4.01	3.47	3.05	2.82	2.63

Remark:

TC : Total capacity ; kW

SC: Sensible heat capacity ; kW

Input: Input power ; kW

MS11D-21HRN1 / MO11D-21HN1**Cooling**

Cooling		Outdoor conditions (DB)				
Indoor Conditions	(kW)	18°C	21°C	28°C	35°C	43°C
21/15°C DB/WB	TC	6.64	6.33	6.03	5.72	5.47
	SC	4.78	4.69	4.64	4.58	4.60
	Input	2.09	2.17	2.35	2.45	2.53
24/17°C DB/WB	TC	6.77	6.52	6.21	5.90	5.54
	SC	4.94	4.89	4.84	4.78	4.65
	Input	2.11	2.30	2.45	2.56	2.69
27/19°C DB/WB	TC	6.89	6.64	6.33	6.15	5.72
	SC	4.96	4.92	4.88	4.80	4.69
	Input	2.19	2.35	2.48	2.61	2.74
32/23°C DB/WB	TC	7.01	6.77	6.52	6.40	5.90
	SC	5.82	5.75	5.67	5.63	5.49
	Input	2.35	2.45	2.56	2.74	2.84

Heating

Heating		Outdoor conditions				
Indoor Conditions (DB)	(kW)	24/18°C DB/WB	7/6°C DB/WB	2/1°C DB/WB	-5/-6°C DB/WB	-7/-8°C DB/WB
15°C	TC	8.76	7.08	5.80	5.26	4.92
	Input	3.25	2.80	2.41	2.26	2.14
20°C	TC	8.49	6.74	5.46	5.12	4.72
	Input	3.55	3.01	2.65	2.44	2.29
27°C	TC	7.95	6.34	5.12	4.99	4.45
	Input	3.76	3.25	2.86	2.65	2.47

Remark:

TC : Total capacity ; kW

SC: Sensible heat capacity ; kW

Input: Input power ; kW

MS11D-24HRN1 / MO11D-24HN1

Cooling

Cooling		Outdoor conditions (DB)				
Indoor Conditions	(kW)	18°C	21°C	28°C	35°C	43°C
21/15°C DB/WB	TC	7.59	7.24	6.89	6.54	6.26
	SC	5.47	5.36	5.30	5.23	5.26
	Input	2.09	2.17	2.35	2.45	2.53
24/17°C DB/WB	TC	7.73	7.45	7.10	6.75	6.33
	SC	5.65	5.59	5.54	5.47	5.31
	Input	2.11	2.30	2.45	2.56	2.69
27/19°C DB/WB	TC	7.87	7.59	7.24	7.03	6.54
	SC	5.67	5.62	5.58	5.48	5.36
	Input	2.19	2.35	2.48	2.61	2.74
32/23°C DB/WB	TC	8.01	7.73	7.45	7.31	6.75
	SC	6.65	6.57	6.48	6.43	6.28
	Input	2.35	2.45	2.56	2.74	2.84

Heating

Heating		Outdoor conditions				
Indoor Conditions (DB)	(kW)	24/18°C DB/WB	7/6°C DB/WB	2/1°C DB/WB	-5/-6°C DB/WB	-7/-8°C DB/WB
15°C	TC	9.53	7.70	6.30	5.72	5.35
	Input	3.26	2.81	2.42	2.27	2.14
20°C	TC	9.24	7.33	5.94	5.57	5.13
	Input	3.56	3.02	2.66	2.45	2.30
27°C	TC	8.65	6.89	5.57	5.42	4.84
	Input	3.78	3.26	2.87	2.66	2.48

Remark:

TC : Total capacity ; kW

SC: Sensible heat capacity ; kW

Input: Input power ; kW

6. Refrigerant Cycle Diagram

Heating pump mode:

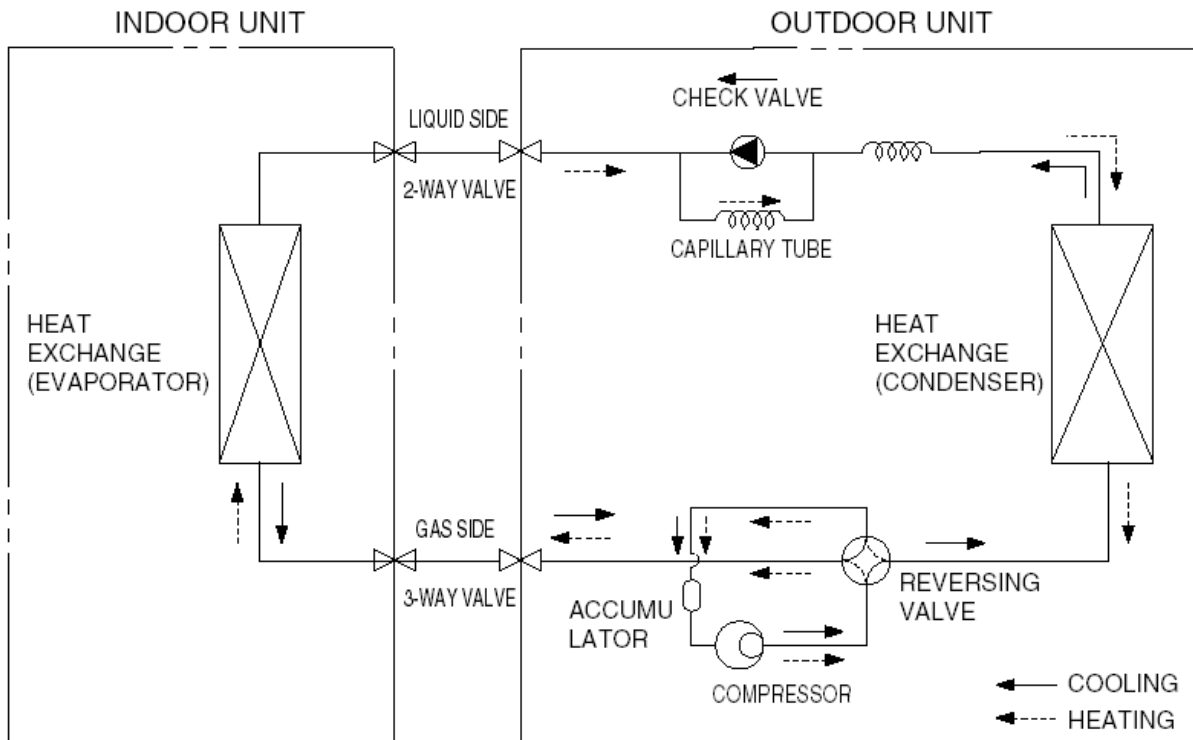

7. Wiring Diagram

7.1 Indoor Units

MS11D-07HRN1, MS11D-09HRN1, MS11D-12HRN1, MS11D-18HRN1

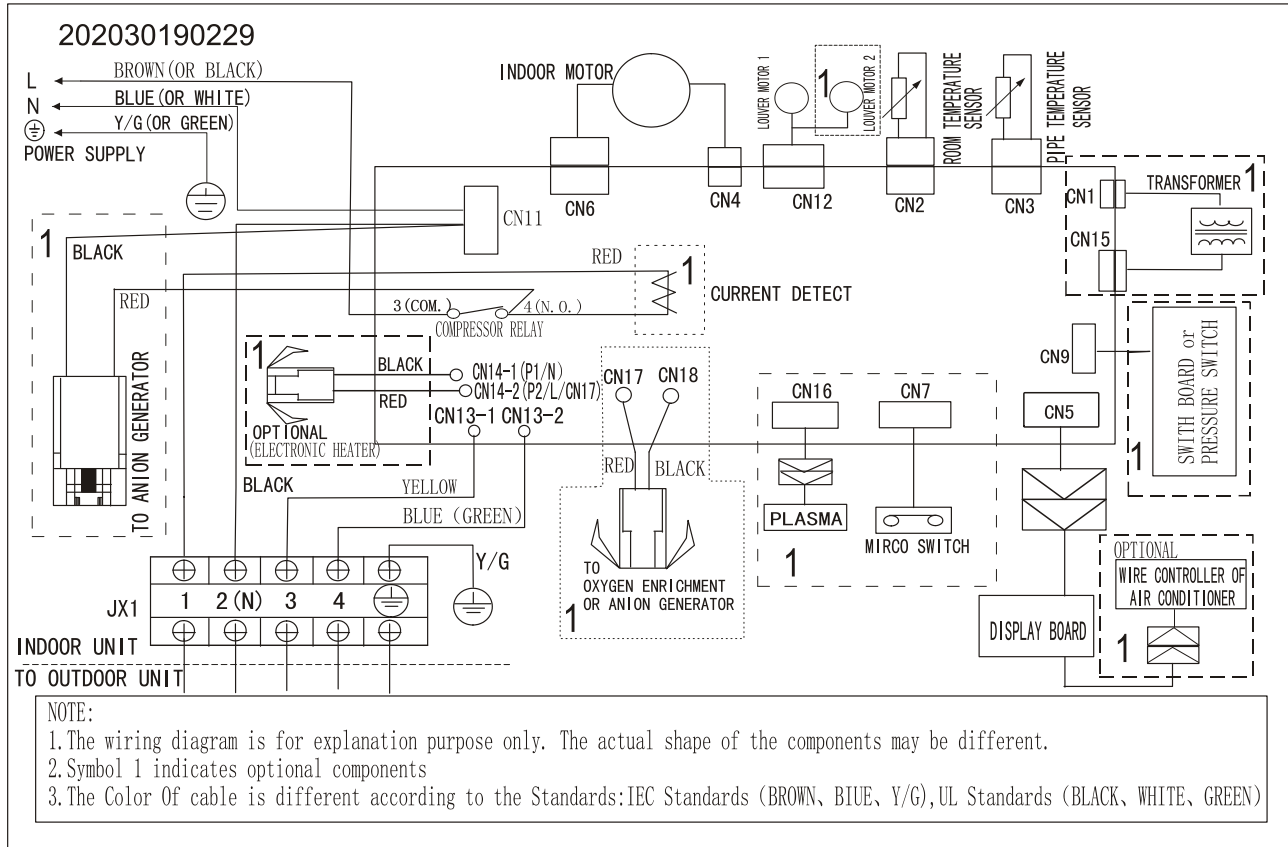

MS11D-21HRN1, MS11D-24HRN1

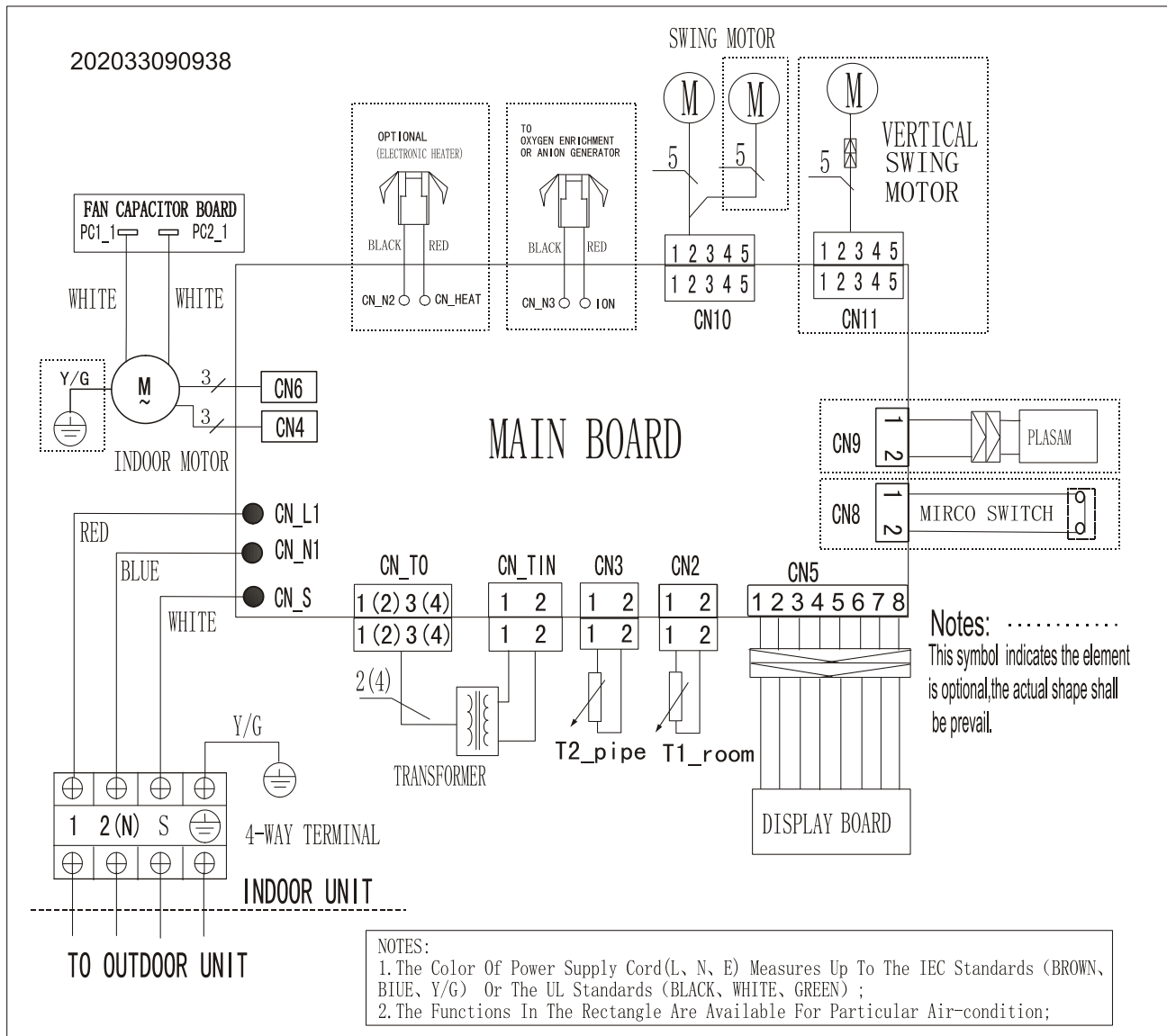

7.2 Outdoor Units

MO11D-07HN1, MO11D-09HN1, MO11D-12HN1, MO11D-18HN1

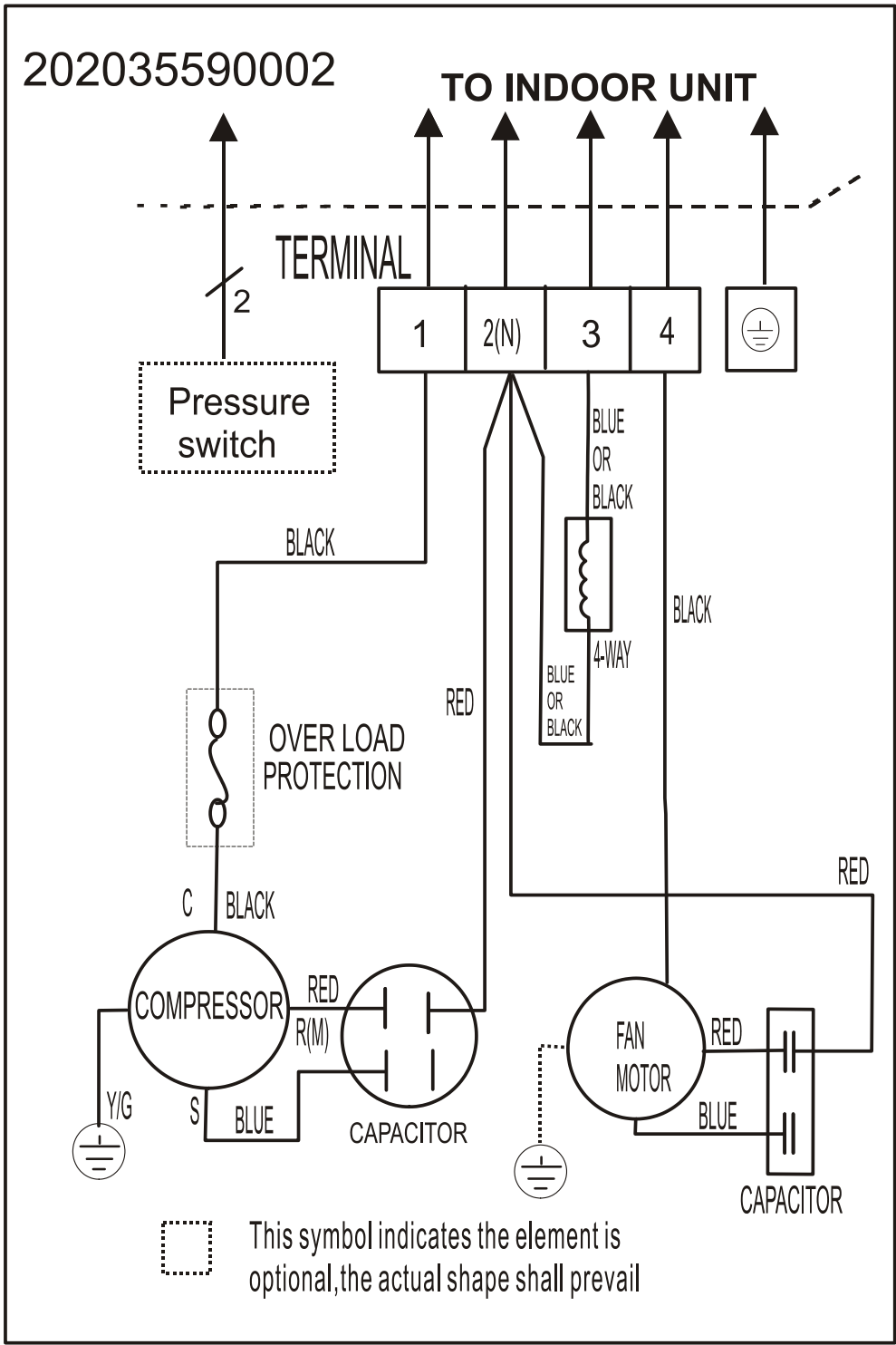

MO11D-21HN1, MO11D-24HN1

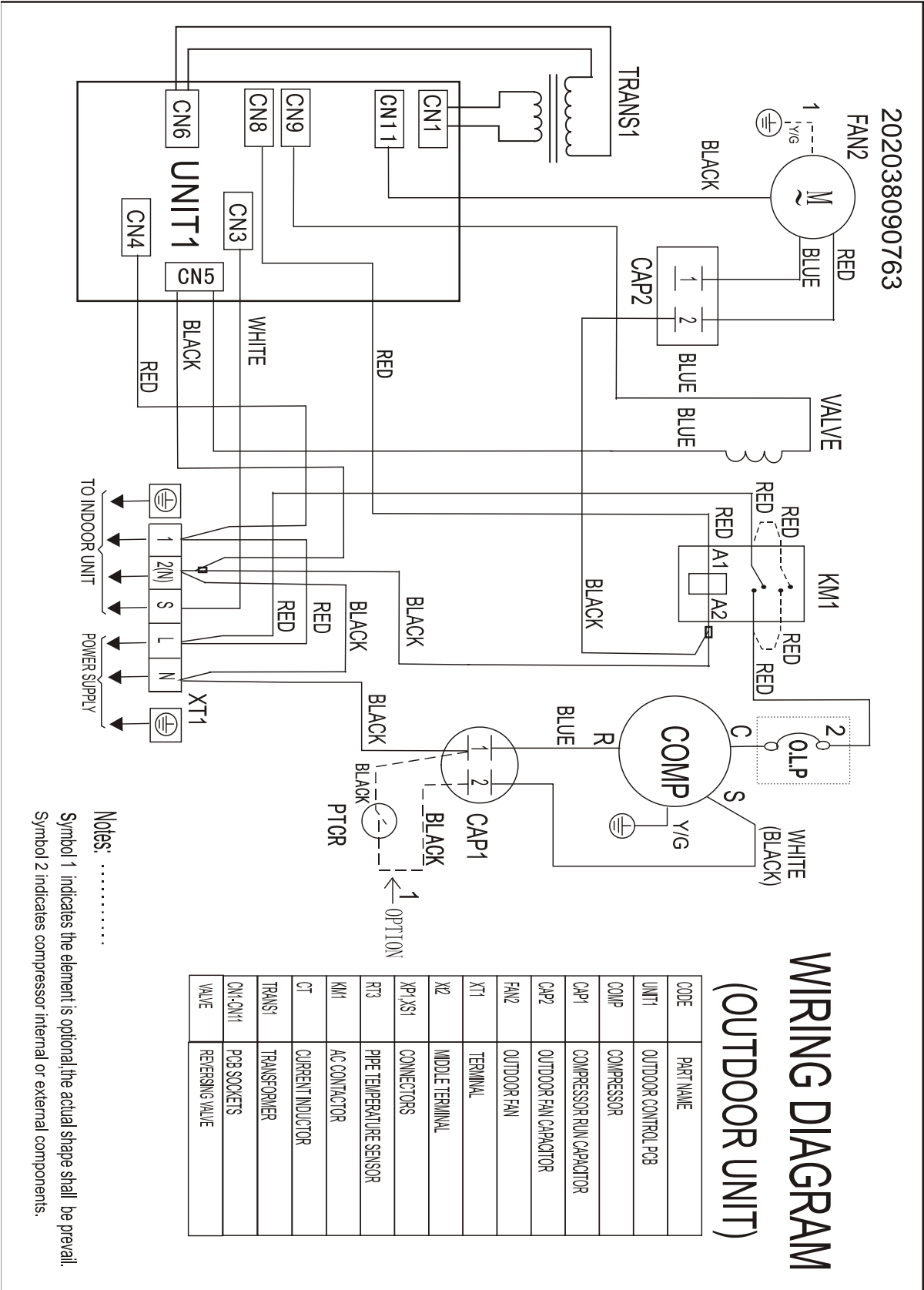

8. Installation details

8.1 Wrench torque sheet for installation

Outside diameter		Torque	Additional tightening torque
mm	inch	N.cm	N.cm
Ø6.35	1/4	1500 (153kgf.cm)	1600 (163kgf.cm)
Ø9.52	3/8	2500 (255kgf.cm)	2600 (265kgf.cm)
Ø12.7	1/2	3500 (357kgf.cm)	3600 (367kgf.cm)

8.2 Connecting the cables

The power cord of connect should be selected according to the following specifications sheet.

Rated current of appliance	Nominal cross-sectional area (mm ²)
>3 and ≤6	0.75
>6 and ≤10	1.0
>10 and ≤16	1.5
>16 and ≤25	2.5

The cable size and the current of the fuse or switch are determined by the maximum current indicated on the nameplate which located on the side panel of the unit. Please refer to the nameplate before selecting the cable, fuse and switch.

8.3 Pipe length and the elevation

The pipe length and refrigerant amount:

Capacity	Connective pipe length	Air purging	Additional amount of refrigerant
All	Less than 5m	Use vacuum pump	-----
7k,9k,12k,18k	More than 5m	Use vacuum pump	(Pipe length – 5) × 30g/m
21K, 24K	More than 5m	Use vacuum pump	(Pipe length – 5) × 60g/m

Capacity	Standard length (m)	Max. Elevation B (m)	Max. Length A (m)
7k,9k,12k	5	5	10
18k	5	8	15
21K, 24K	5	10	20

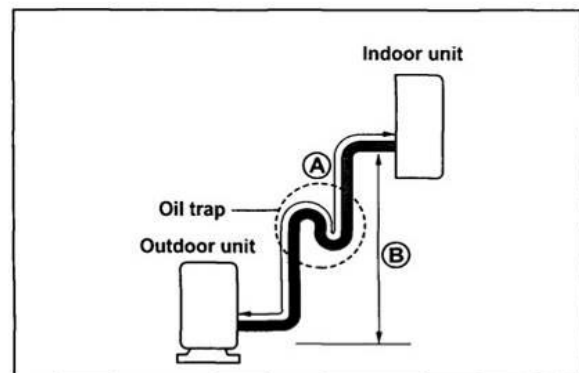
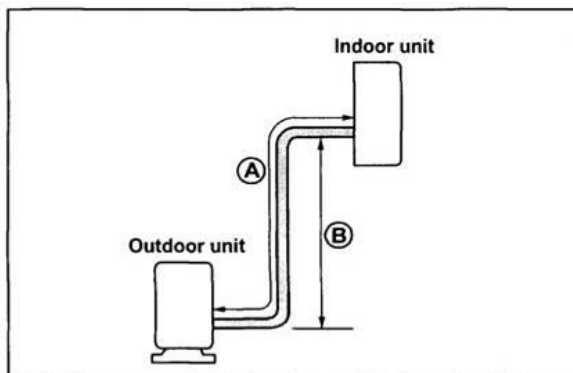

Caution:

Capacity test is based on standard length and maximum allowance length is based on system reliability.

Oil trap should be installed per 5-7 meters.

8.4 Installation for the first time

Air and moisture in the refrigerant system have undesirable effects as below:

- Pressure in the system rises.
- Operating current rises.
- Cooling or heating efficiency drops.

- Moisture in the refrigerant circuit may freeze and block capillary tubing.
- Water may lead to corrosion of parts in the refrigerant system.

Therefore, the indoor units and the pipes between indoor and outdoor units must be leak tested and evacuated to remove gas and moisture from the system.

Gas leak check (Soap water method):

Apply soap water or a liquid neutral detergent on the indoor unit connections or outdoor unit connections by a soft brush to check for leakage of the connecting points of the piping. If bubbles come out, the pipes have leakage.

1. Air purging with vacuum pump

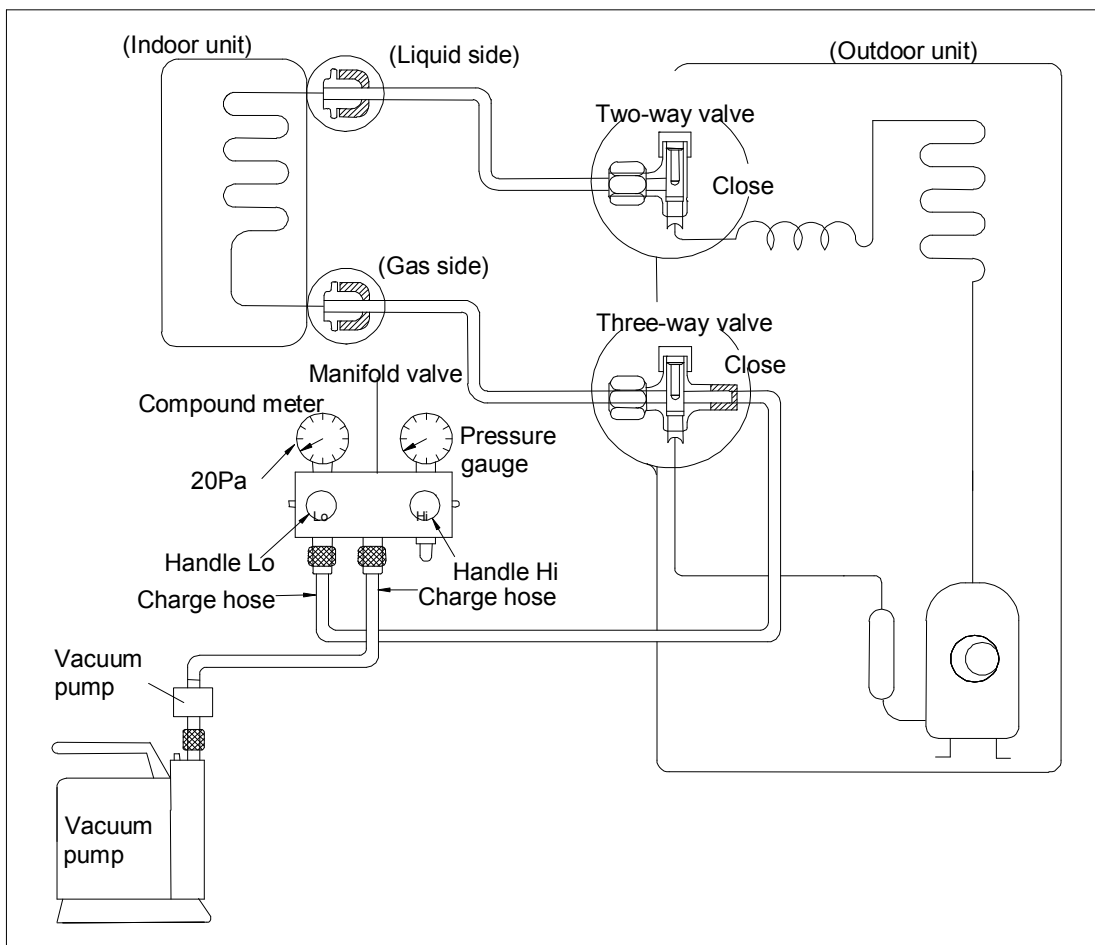

1. Completely tighten the flare nuts of the indoor and outdoor units, confirm that both the 2-way and 3-way valves are set to the closed position.
 2. Connect the charge hose with the push pin of handle lo to the 3-way valves gas service port..
 3. Connect the charge hose of handle hi connection to the vacuum pump.
 4. Fully open the handle Lo of the manifold valve.
 5. Operate the vacuum pump to evacuate.
 6. Make evacuation for 30 minutes and check whether the compound meter indicates -0.1Mpa. If the meter does not indicate -0.1Mpa after pumping 30 minutes, it should be pumped 20 minutes more. If the pressure can't achieve -0.1Mpa after pumping 50 minutes, please check if there are some leakage points.
- Fully close the handle Lo valve of the manifold valve and stop the operation of the vacuum pump. Confirm that the gauge needle does not move (approximately 5 minutes after turning off the vacuum pump).

7. Turn the flare nut of the 3-way valves about 45° counterclockwise for 6 or 7 seconds after the gas coming out, then tighten the flare nut again. Make sure the pressure display in the pressure indicator is a little higher than the atmosphere pressure. Then remove the charge hose from the 3 way valve.
8. Fully open the 2 way valve and 3 way valve and securely tighten the cap of the 3 way valve.

2. Air purging by refrigerant

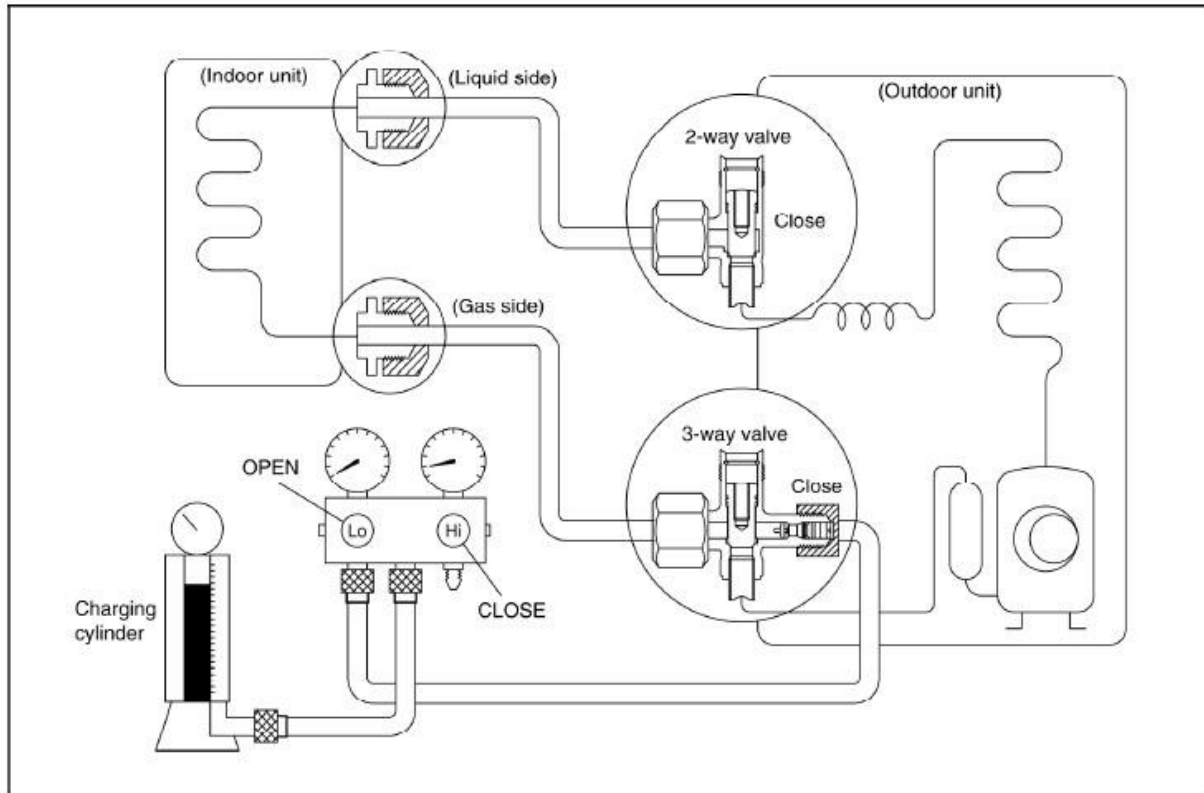

Procedure:

- 1). Confirm that both the 2-way and 3-way valves are set to the closed position.
- 2). Connect the charge set and a charging cylinder to the service port of the 3-way valve.
- 3). Air purging.

Open the valves on the charging cylinder and the charge set. Purge the air by loosening the flare nut on the 2-way valve approximately 45° for 3 seconds then closing it for 1 minute; repeat 3 times.

After purging the air, use a torque wrench to tighten the flare nut on the 2-way valve.

- 4). Check the gas leakage.

Check the flare connections for gas leakage.

- 5). Discharge the refrigerant.

Close the valve on the charging cylinder and discharge the refrigerant by loosening the flare nut on the 2-way valve approximately 45° until the gauge indicates 0.3 to 0.5 Mpa.

- 6). Disconnect the charge set and the charging cylinder, and set the 2-way and 3-way valves to the open position.

Be sure to use a hexagonal wrench to operate the valve stems.

7). Mount the valve stems nuts and the service port cap.

Be sure to use a torque wrench to tighten the service port cap to a torque 18N·m.

Be sure to check the gas leakage.

3. Adding the refrigerant if the pipe length >5m

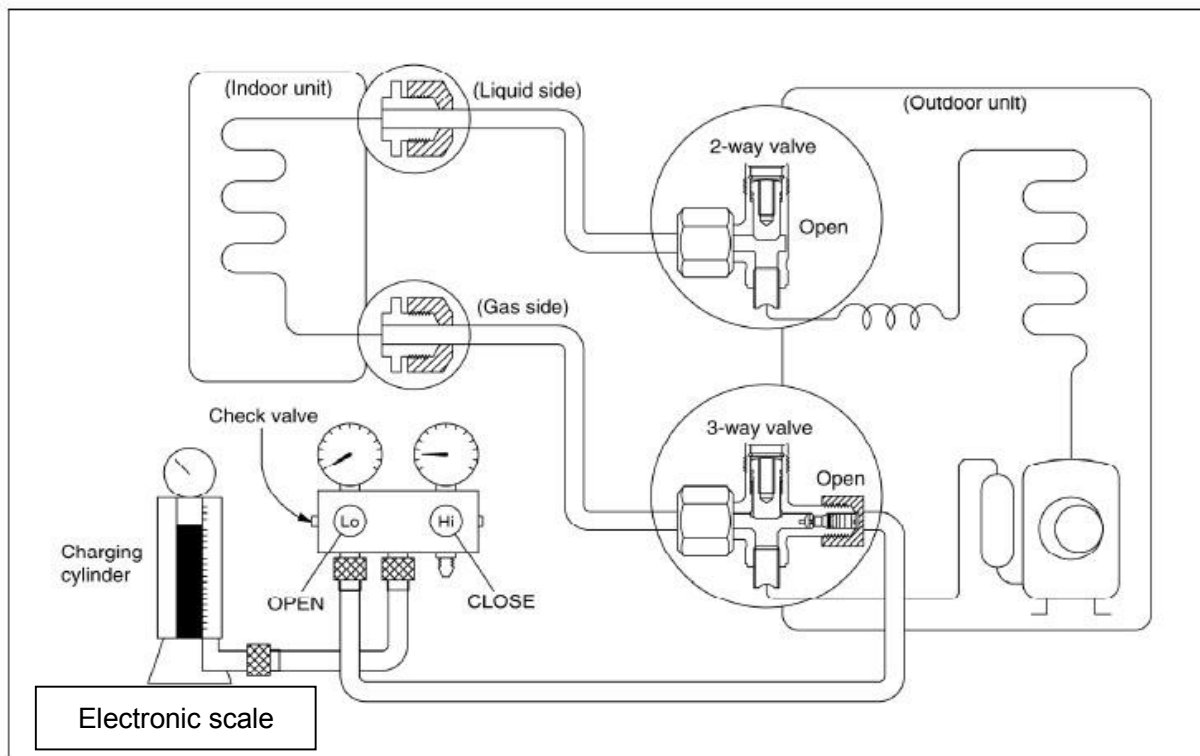

Procedure:

1). Connect the charge hose to the charging cylinder, open the 2-way valve and the 3-way valve.

Connect the charge hose which you disconnected from the vacuum pump to the valve at the bottom of the cylinder. If the refrigerant is R410A, make the cylinder bottom up to ensure the liquid charge.

2). Purge the air from the charge hose.

Open the valve at the bottom of the cylinder and press the check valve on the charge set to purge the air (be careful of the liquid refrigerant).

3) Put the charging cylinder onto the electronic scale and record the weight.

4) Operate the air conditioner at the cooling mode.

5) Open the valves (Low side) on the charge set and charge the system with liquid refrigerant.

6).When the electronic scale displays the proper weight (refer to the table), disconnect the charge hose from the 3-way valve's service port immediately and turn off the air conditioner before disconnecting the hose.

7). Mount the valve stem caps and the service port

Use torque wrench to tighten the service port cap to a torque of 18N.m.

Be sure to check for gas leakage.

8.5 Adding the refrigerant after running the system for many years

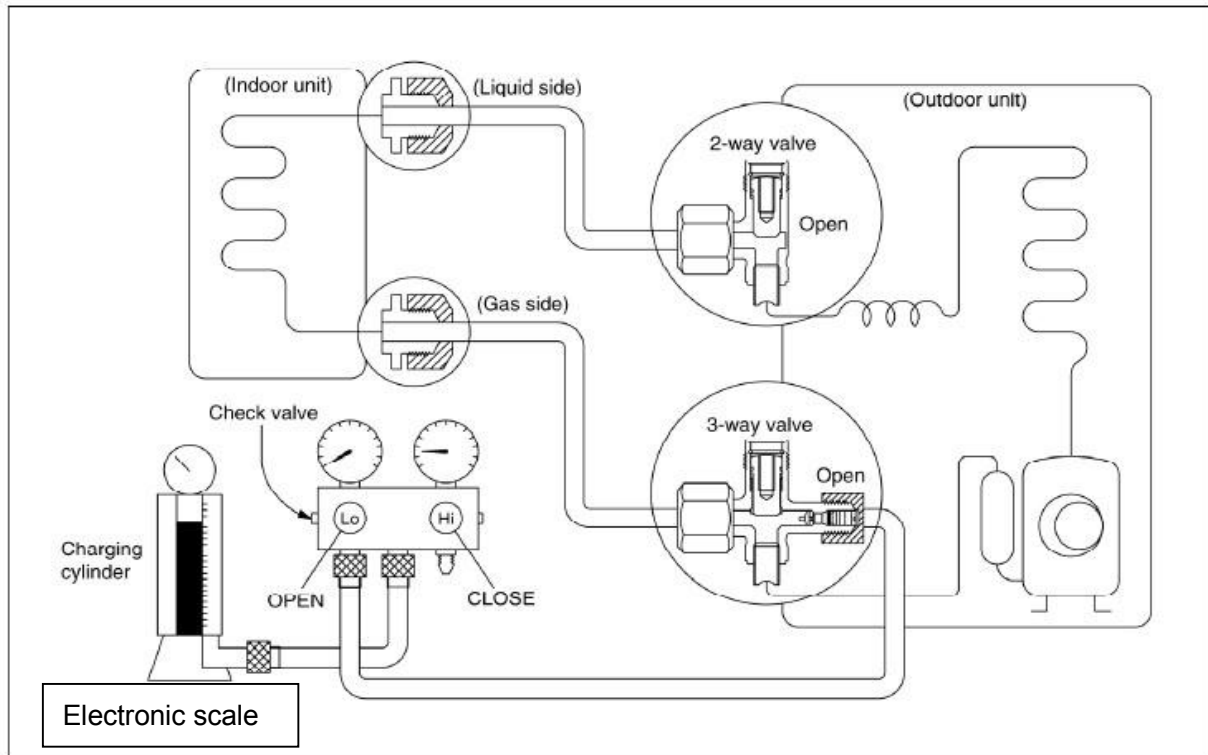

Procedure:

- 1). Connect the charge hose to the 3-way service port, open the 2-way valve and the 3-way valve. Connect the charge hose to the valve at the bottom of the cylinder. If the refrigerant is R410A, make the cylinder bottom up to ensure liquid charge.
- 2). Purge the air from the charge hose.
Open the valve at the bottom of the cylinder and press the check valve on the charge set to purge the air (be careful of the liquid refrigerant).
- 3) Put the charging cylinder onto the electronic scale and record the weight.
- 4) Operate the air conditioner at the cooling mode.
- 5) Open the valves (Low side) on the charge set and charge the system with liquid refrigerant.
- 6).When the electronic scale displays the proper weight (refer to the gauge and the pressure of the low side), disconnect the charge hose from the 3-way valve's service port immediately and turn off the air conditioner before disconnecting the hose.
- 7). Mount the valve stem caps and the service port

Use torque wrench to tighten the service port cap to a torque of 18N.m.

Be sure to check for gas leakage.

8.6 Re-installation while the indoor unit need to be repaired

1. Collecting the refrigerant into the outdoor unit

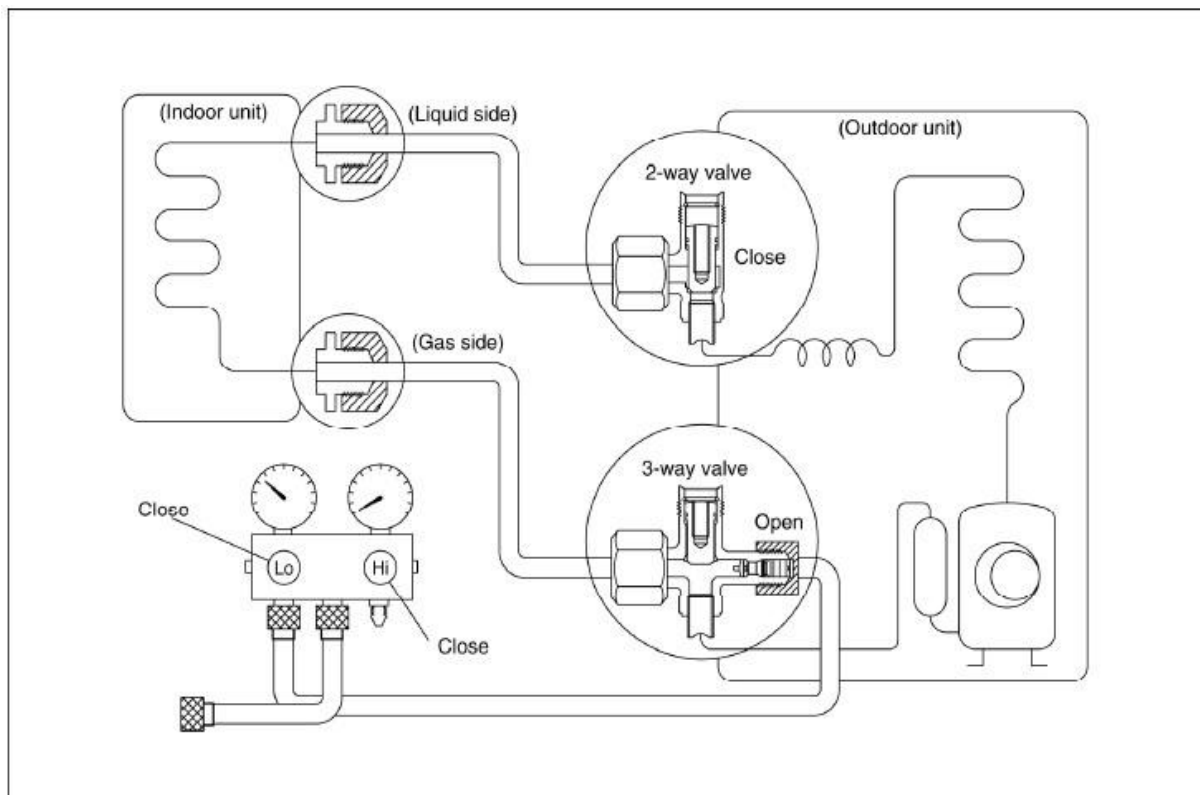

Procedure

1). Confirm that both the 2-way and 3-way valves are set to the opened position

Remove the valve stem caps and confirm that the valve stems are in the opened position.

Be sure to use a hexagonal wrench to operate the valve stems.

2). Connect the charge hose with the push pin of handle lo to the 3-way valves gas service port.

3). Air purging of the charge hose.

Open the handle Lo valve of the manifold valve slightly to purge air from the charge hose for 5 seconds and then close it quickly.

4). Set the 2-way valve to the close position.

5). Operate the air conditioner at the cooling cycle and stop it when the gauge indicates 0.1MPa.

6). Set the 3-way valve to the closed position immediately

Do this quickly so that the gauge ends up indicating 0.3 to 0.5Mpa.

Disconnect the charge set, and tighten the 2-way and 3-way valve's stem nuts.

Use a torque wrench to tighten the 3-way valves service port cap to a torque of 1.8 kgf.m.

Be sure to check for gas leakage.

2. Air purging by the refrigerant

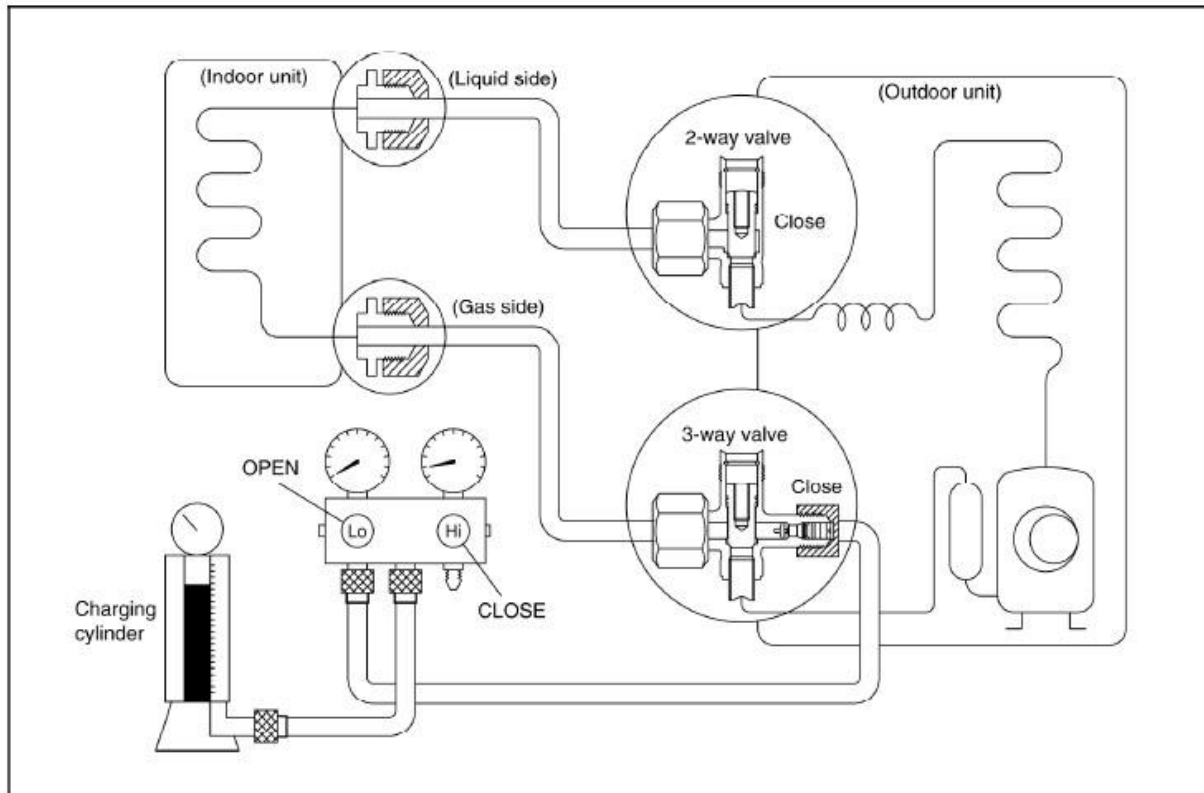

Procedure:

1). Confirm that both the 2-way and 3-way valves are set to the closed position.

2). Connect the charge set and a charging cylinder to the service port of the 3-way valve

Leave the valve on the charging cylinder closed.

3). Air purging.

Open the valves on the charging cylinder and the charge set. Purge the air by loosening the flare nut on the 2-way valve approximately 45° for 3 seconds then closing it for 1 minute; repeat 3 times.

After purging the air, use a torque wrench to tighten the flare nut on the 2-way valve.

4). Check the gas leakage

Check the flare connections for gas leakage.

5). Discharge the refrigerant.

Close the valve on the charging cylinder and discharge the refrigerant by loosening the flare nut on the 2-way valve approximately 45° until the gauge indicates 0.3 to 0.5 Mpa.

6). Disconnect the charge set and the charging cylinder, and set the 2-way and 3-way valves to the open position

Be sure to use a hexagonal wrench to operate the valve stems.

7). Mount the valve stems nuts and the service port cap

Be sure to use a torque wrench to tighten the service port cap to a torque 18N.m.

Be sure to check the gas leakage.

8.7 Re-installation while the outdoor unit need to be repaired

1. Evacuation for the whole system

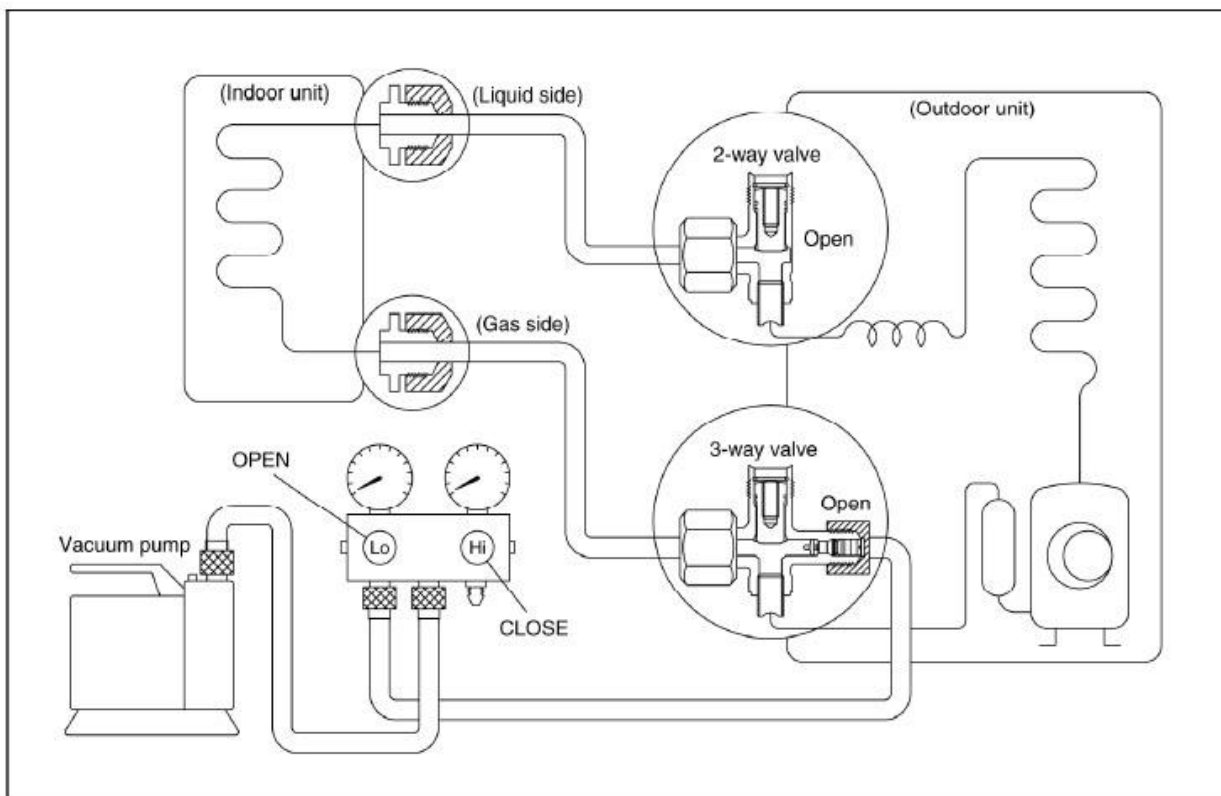

Procedure:

- 1). Confirm that both the 2-way and 3-way valves are set to the opened position.
- 2). Connect the vacuum pump to 3-way valve's service port.
- 3). Evacuation for approximately one hour. Confirm that the compound meter indicates -0.1Mpa.
- 4). Close the valve (Low side) on the charge set, turn off the vacuum pump, and confirm that the gauge needle does not move (approximately 5 minutes after turning off the vacuum pump).
- 5). Disconnect the charge hose from the vacuum pump.

2. Refrigerant charging

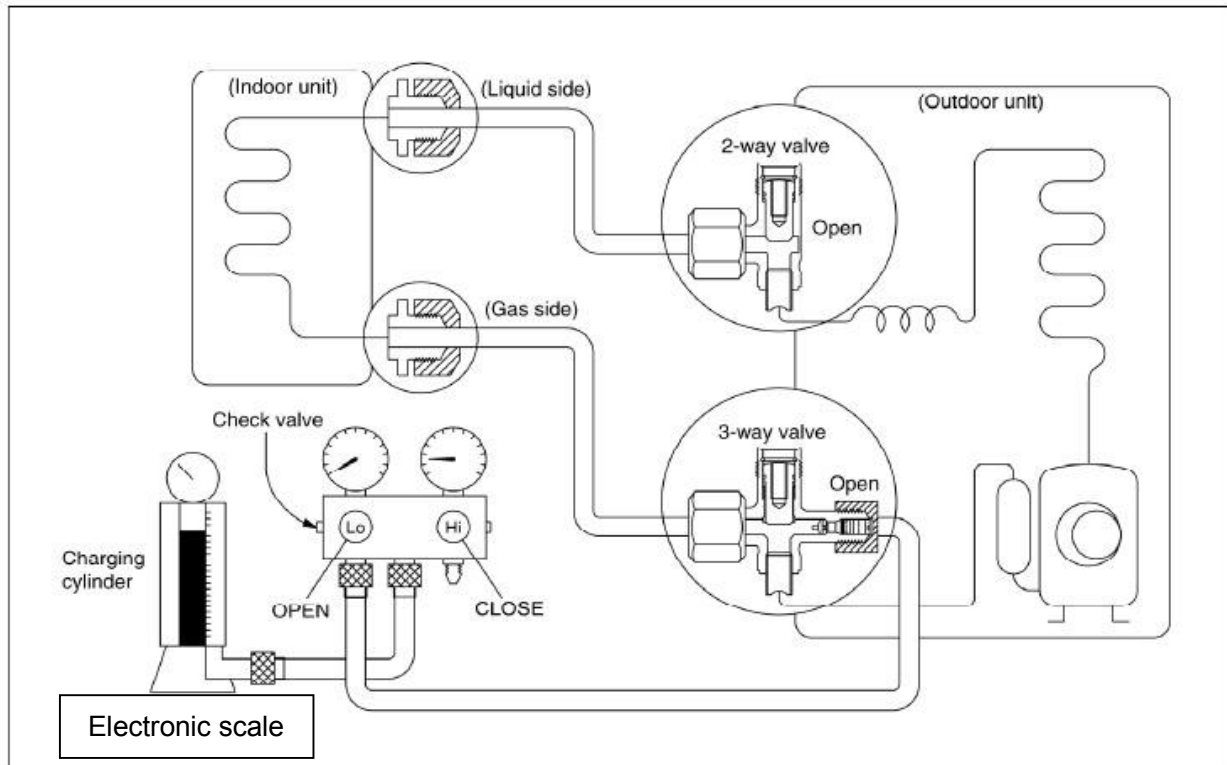

Procedure:

- 1). Connect the charge hose to the charging cylinder, open the 2-way valve and the 3-way valve
Connect the charge hose which you disconnected from the vacuum pump to the valve at the bottom of the cylinder. If the refrigerant is R410A, make the cylinder bottom up to ensure liquid charge.
- 2). Purge the air from the charge hose
Open the valve at the bottom of the cylinder and press the check valve on the charge set to purge the air (be careful of the liquid refrigerant).
- 3) Put the charging cylinder onto the electronic scale and record the weight.
- 4). Open the valves (Low side) on the charge set and charge the system with liquid refrigerant
If the system cannot be charge with the specified amount of refrigerant, or can be charged with a little at a time (approximately 150g each time) , operating the air conditioner in the cooling cycle; however, one time is not sufficient, wait approximately 1 minute and then repeat the procedure.
- 5).When the electronic scale displays the proper weight, disconnect the charge hose from the 3-way valve's service port immediately
If the system has been charged with liquid refrigerant while operating the air conditioner, turn off the air conditioner before disconnecting the hose.
- 6). Mounted the valve stem caps and the service port

Use torque wrench to tighten the service port cap to a torque of 18N.m.

Be sure to check for gas leakage

9. Operation characteristics

Temperature Mode	Cooling operation	Heating operation	Drying operation
Room temperature	17°C ~ 32°C	0°C ~ 30°C	10°C ~ 32°C (<21000Btu/h models)
			17°C ~ 32°C (≥21000Btu/h models)
Outdoor temperature	18°C ~ 43°C	-7°C ~ 24°C	11°C ~ 43°C (<21000Btu/h models)
			18°C ~ 43°C (≥21000Btu/h models)

CAUTION:

1. If air conditioner is used outside of the above conditions, certain safety protection features may come into operation and cause the unit to function abnormally.

2. Room relative humidity less than 80%. If the air conditioner operates in excess of this figure, the surface of the air conditioner may attract condensation. Please set the vertical air flow louver to its maximum angle (vertically to the floor), and set HIGH fan mode.

3. Optimum performance will be achieved within this operating temperature.

10. Electronic function

10.1 Abbreviation

T1: Indoor ambient temperature

T2: Coil temperature of indoor heat exchanger

10.2 Display function

10.2.1 Icon explanation on indoor display board.

One of the following figures matches its display board .

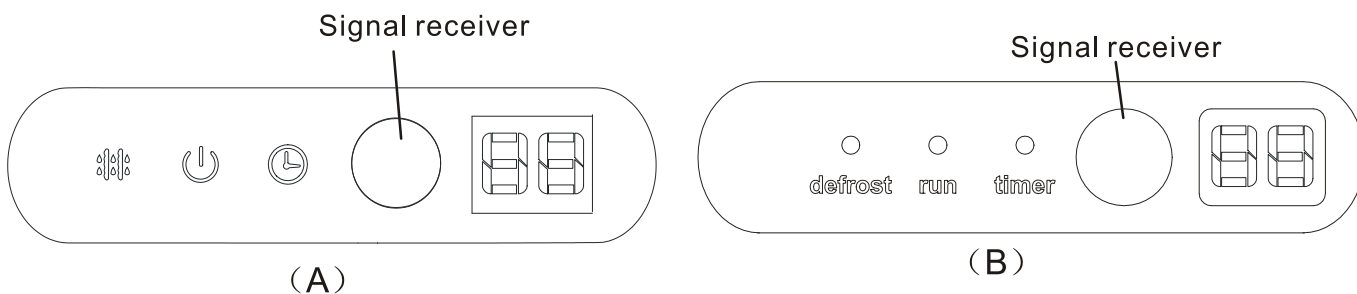

	<p>Run indicator Flash at 0.5Hz when the unit is standby. Illuminate when the unit is turned on.</p>
	<p>Timer indicator This indicator illuminates when TIMER is set ON/OFF.</p>
	<p>Defrost Indicator This indicator illuminates when the air conditioner starts defrosting automatically or when the warm air control feature is activated in heating mode</p>
	<p>Temperature indicator Displays the temperature settings when the air conditioner is operational. Displays the malfunction code.</p>

10.3 Main Protection

10.3.1 Time Delay at restart for compressor.

10.3.2 Sensor protection at open circuit and breaking disconnection.

10.3.3 Zero crossing detection error protection

If AC cannot detect zero crossing signal for 4 minutes or the zero crossing signal time interval is not correct, the unit will stop and the LED will display the failure. The correct zero crossing signal time interval should be between 6-13 ms.

8.3.4 Fan Speed is out of control

When Indoor Fan Speed is too low(lower than 300RPM) lasting 50 seconds, the unit stops and LED displays failure information and can't returns to normal operation automatically.

10.4 Operation Modes and Functions

10.4.1 Fan mode.

- (1) Outdoor fan and compressor stop.
- (2) Temperature setting function is disabled, and no setting temperature is displayed.
- (3) Indoor fan can be set to high/med/low/auto.
- (4) The louver operates same as in cooling mode.
- (5) Auto fan:

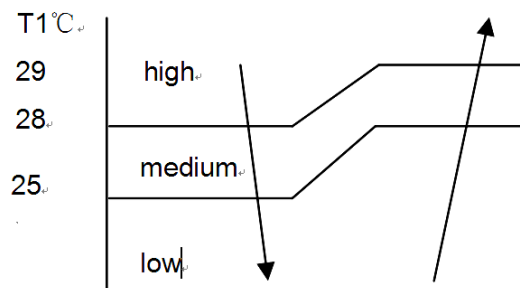

10.4.2 Cooling Mode

10.4.2.1 Compressor running rules:

Once the compressor starts up, it will follow the below rules:

When indoor room temp. T_1 is lower than T_n , the compressor and outdoor fan will shut off. When T_1 is higher than T_m , the compressor and outdoor fan will start up. (If the unit has refrigerant leakage Detect function, the compressor will run 5.5 minutes first.)

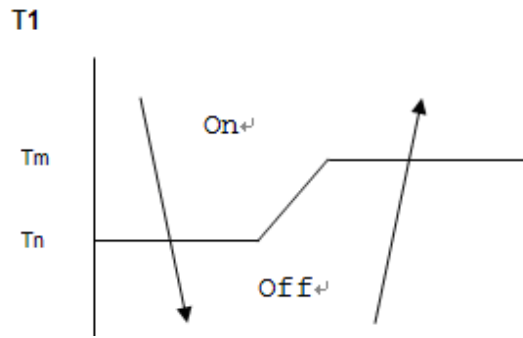

$T_m = T_s$, $T_n = T_s - 2$.

10.4.2.2 Outdoor fan running rules:

The On-off outdoor units have single fan speed. The outdoor fan will run following the compressor except when AC is in evaporator high temp. protection in heating mode, condenser high temp. protection in cooling mode, defrosting mode and the current protection.

10.4.2.3 Indoor fan running rules

In cooling mode, indoor fan runs all the time and the speed can be selected as high, medium, low and auto.

The auto fan:

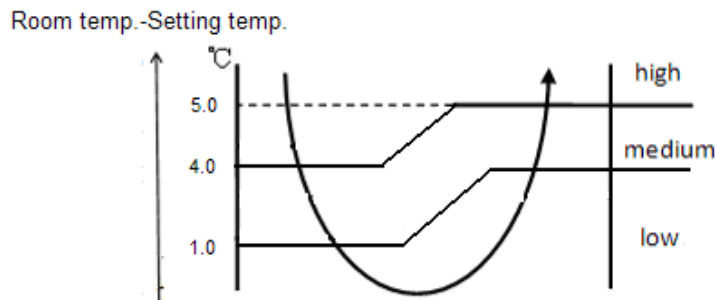

10.4.2.4 Evaporator low temperature T2 protection.

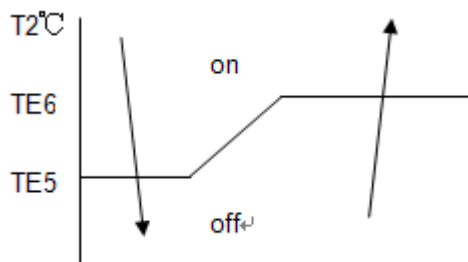

When the evaporator coil temp. T2 keeps lower than TE5 for 5 minutes, the compressor and outdoor fan will shut off.

When T2 is higher than TE6, the compressor and outdoor fan will restart up.

While TE5=4 °C, TE6=10 °C for 7k,9k,12k,18k model and TE5=3 °C, TE6=14 °C for 21,24 model.

10.4.3 Heating Mode (For Heating & Cooling model)

10.4.3.1 Compressor running rules:

When indoor room temp. T_1 is higher than T_j , the compressor and outdoor fan will shut off. When T_1 is lower than T_k , the compressor and outdoor fan will start up.

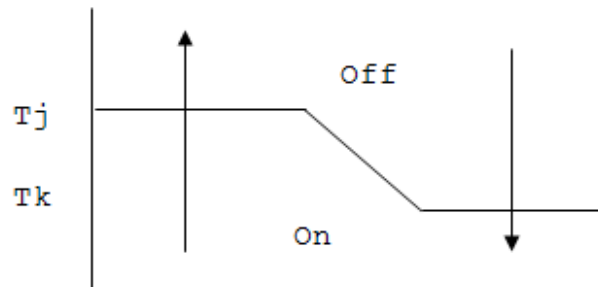

While $T_j = T_s + 4$; $T_k = T_s + 2$ for 7k, 9k, 12k, 18k model and $T_j = T_s$; $T_k = T_s - 2$ for 24K, 28K model

10.4.3.2 Outdoor fan running rules:

The outdoor units have single fan speed. The outdoor fan will run following the compressor except when AC is in evaporator high temp. protection in heating mode, condenser high temp. protection in cooling mode, defrosting mode and the current protection.

10.4.3.3 Indoor fan running rules:

When the compressor is on, the indoor fan can be set to high/med/low/auto. And the anti-cold wind function has the priority.

Anti-cold wind function:

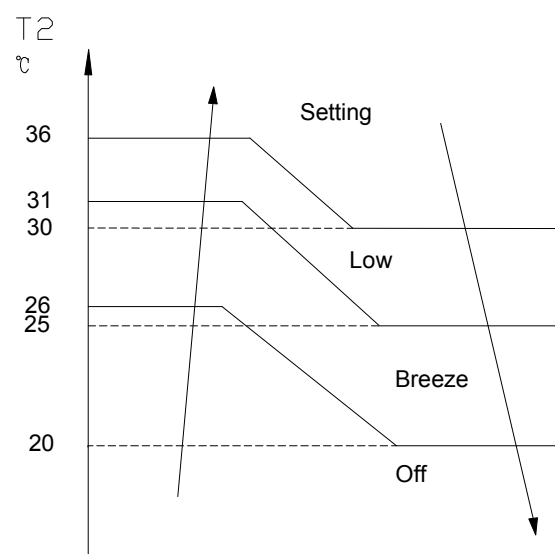

Auto fan action:

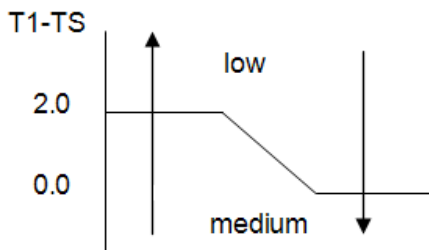

When $T1-Ts > 2$, the indoor fan will run at low speed.

When $T1-Ts \leq 0$, the indoor fan will run at medium speed.

10.4.3.4 Defrosting mode:

● **Condition of defrosting:**

1、 AC will enter defrosting mode if all of the following items is satisfied.

1.1 After the compressor keeps running 8 minutes, $\Delta T_{max} - \Delta T_{min} \geq 4^{\circ}C$ ($\Delta T = T2 - T1$)

1.2 AC meets A1 or A2.

A1: The cumulative compressor running time is between 45~120 minutes. Meanwhile the value of $T2 - T1$ meets the below table.

$^{\circ}C$	ΔT
High speed	$< TH_{DEFROST}$
Medium speed	$< TM_{DEFROST}$
Low speed	$< TL_{DEFROST}$
Breeze/off	No need to compare the T2 and T1

A2: The cumulative compressor running time is over 120 minutes. Meanwhile the value of ΔT meets the below table.

$^{\circ}C$	ΔT
High speed	$< TH_{DEFROST} + 2$
Medium speed	$< TM_{DEFROST} + 2$
Low speed	$< TL_{DEFROST} + 2$

While

Model	$TH_{DEFROST}(^{\circ}C)$	$TM_{DEFROST}(^{\circ}C)$	$TL_{DEFROST}(^{\circ}C)$
7k	14	15	16
9k	14	15	16
12k	12	13	14
18k	17	18	19
21K	16	17	18
24K	16	17	18

1.3

°C	T2
High speed	<43°C
Medium speed	<46°C
Low speed	<48°C

About the setting defrosting time:

	condition	runtime (minute)	Defrosting time (minute)
Case 1	①A、B1	Runtime=45	10
Case 2	①A、B1	45<runtime≤60	7.5
Case 3	①A、B1	60<runtime≤90	8.5
Case 4	①A、B1	90<runtime≤120	10
Case 5	①A、B1	120<runtime	12

2、The cumulative compressor running time is over 45 minutes .Meanwhile the indoor fan off or run in breeze mode automatically (for Anti-cold wind function), AC will enter defrosting mode and the defrosting time is ten minutes.

3、If the AC haven't defrost before running and the indoor fan running in slow mode over 2 minutes, meanwhile 1.2 and 1.3 is satisfied and the cumulative compressor running time is over 45 minutes, AC will enter defrosting mode and the defrosting time is ten minutes.

- **Condition of ending defrosting:**

If any one of the following items is satisfied, the defrosting will terminate and the machine will turn to normal heating mode.

- (1) The defrosting time is reached to the setting value.
- (2) After defrosting for 3 minutes, $T_2 \geq 2^\circ\text{C}$.
- (3) If the defrosting time is between 2 and 4 minutes, $T_{2\text{max}} - T_{2\text{min}} \geq 2^\circ\text{C}$.

● Defrosting action:

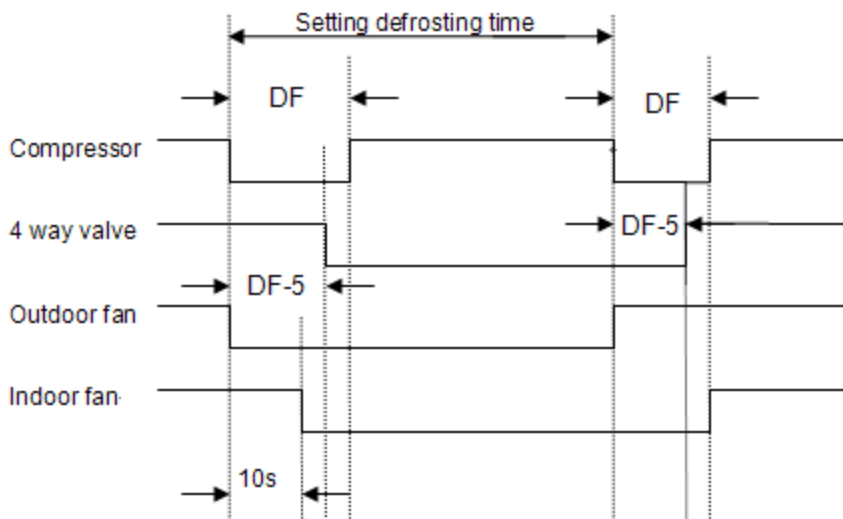

DF=25SEC for 7k,9k,12k and DF=45SEC for 24K,28K

10.4.3.5 High evaporator coil temp.T2 protection:

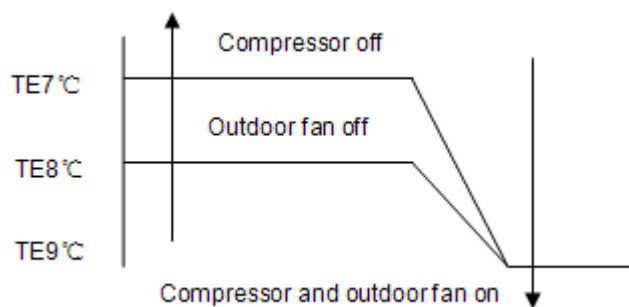

Model	TE7	TE8	TE9
7k	60	53	50
9k	60	53	50
12k	63	53	51
18k	60	53	50
21K	60	53	50
24K	60	53	50

10.4.4 Auto-mode

The machine will choose cooling, heating or fan-only mode according to ΔT ($\Delta T = T1-Ts$).

$\Delta T = T1-Ts$	Running mode
$\Delta T > 2^\circ C$	Cooling
$-3 \leq \Delta T \leq 2^\circ C$	Fan-only
$\Delta T < -3^\circ C$	Heating(for cooling only models, they will run at fan-only mode)

AC will run in auto mode in the below cases:

- (1) Press the forced auto button.
- (2) If AC is off, it will run in auto mode when timer on function is active.

(3) After setting the mode, AC will run in auto mode if the compressor keeps not running for 15 minutes.

10.4.5 Drying mode

10.4.5.1 The compressor is cycled running by 10 minutes on and then 5 minutes off. The indoor fan will keep running at low speed.

10.4.5.2 In drying mode, if the room temperature is lower than 10°C, the indoor fan will run at breeze while the compressor and outdoor fan will stop and not resume until room temperature exceeds 13°C.

10.4.5.3 The system protection is active in this mode.

10.4.6 Forced operation function

Press the touch button continually, the AC will run as below sequence:

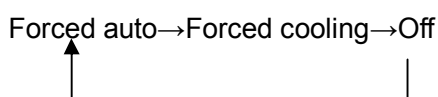

Forced cooling mode:

The compressor and outdoor fan keep running and the indoor fan runs at low speed. After running for 30 minutes, AC will turn to auto mode with 24°C setting temperature.

Forced auto mode:

The action of forced auto mode is the same as normal auto mode with 24°C setting temperature.

- When AC receives signals, such as switch on, switch off, timer on, timer off, mode setting, fan speed setting, sleeping mode setting, follow me setting, it will quit the forced operation.
- The forced operation function cannot be memorized if power off.

10.4.7 Timer function

10.4.7.1 Timing range is 24 hours.

10.4.7.2 Timer on. The machine will turn on automatically when reaching the setting time.

10.4.7.3 Timer off. The machine will turn off automatically when reaching the setting time.

10.4.7.4 Timer on/off. The machine will turn on automatically when reaching the setting “on” time, and then turn off automatically when reaching the setting “off” time.

10.4.7.5 Timer off/on. The machine will turn off automatically when reaching the setting “off” time, and then turn on automatically when reaching the setting “on” time.

10.4.7.6 For 12k and 18k models, the timer function will not change the AC current operation mode.

Suppose users set the “timer off” function and AC is off now, the AC will keep the current running mode and then turn off when reaching the setting time.

10.4.7.7 The setting time is relative time.

10.4.8 Sleep function mode

10.4.8.1 Operation time in sleep mode is 7 hours. After 7 hours, the AC quits this mode and turns off.

10.4.8.2. Operation process in sleep mode is as follow:

After pressing ECONOMIC or SLEEP button on controller, the machine will turn into sleep mode.

When cooling, the setting temperature rises 1 °C (be lower than 30 °C) every one hour, 2 hours later the setting temperature stops rising and indoor fan is fixed as low speed.

When heating, the setting temperature decreases 1 °C (be higher than 17 °C) every one hour, 2 hours later the setting temperature stops rising and indoor fan is fixed as low speed. (Anti-cold wind function has the priority)

10.4.8.3 Timer setting is available.

9.4.8.4 When user uses timer off function in sleep mode (or sleep function in timer off mode), if the timing is less than 7 hours, sleep function will be cancelled when reaching the setting time. If the timing is more than 7 hours, the machine will not stop until reaches the setting time in sleep mode.

10.4.9 Auto-Restart function

The indoor unit is equipped with auto-restart function, which is carried out through an auto-restart module. In case of a sudden power failure, the module memorizes the setting conditions before the power failure. The unit will resume the previous operation setting (not including Swing function) automatically after 3 minutes when power returns.

If the memorization condition is forced cooling mode, the unit will run in cooling mode for 30 minutes and then turn to drying mode as 24 °C setting temp.

11. Troubleshooting

11.1 Indoor unit error display

For 7k, 9k, 12k, 18k

Display	Operation lamp flash times	Timer lamp	Failure
E1	1	X	EEPROM error
E2	2	X	Zero crossing detection error
E3	3	X	Indoor fan speed has been out of control
E4	4	X	Default
E5	5	X	Indoor room temperature sensor T1 open circuit
E6	6	X	Evaporator coil temperature sensor T2 open
E7	7	X	Condenser coil temperature sensor T3 open
EC	2	O	Refrigerant leak detection error

O (light) X (off) ☆ (flash)

For 21K, 24K

Display	Operation lamp flash times	Timer lamp	Failure
E1	1	X	EEPROM error
E2	2	X	Zero crossing detection error
E3	3	X	Indoor fan speed has been out of control.
E4	4	X	Default
E5	5	X	Indoor room temperature sensor T1 open circuit or short circuit
E6	6	X	Evaporator coil temperature sensor T2 open circuit or short circuit
E7	7	X	Condenser coil temperature sensor T3 open
EC	2	O	Refrigerant leak detection error
E8	8	X	Outdoor fan speed has been out of control or outdoor unit phase error.
E9	9	X	Indoor unit and outdoor unit communication error

O (light) X (off) ☆ (flash)

11.2 Diagnosis and Solution

11.2.1 Indoor fan speed out of control diagnosis

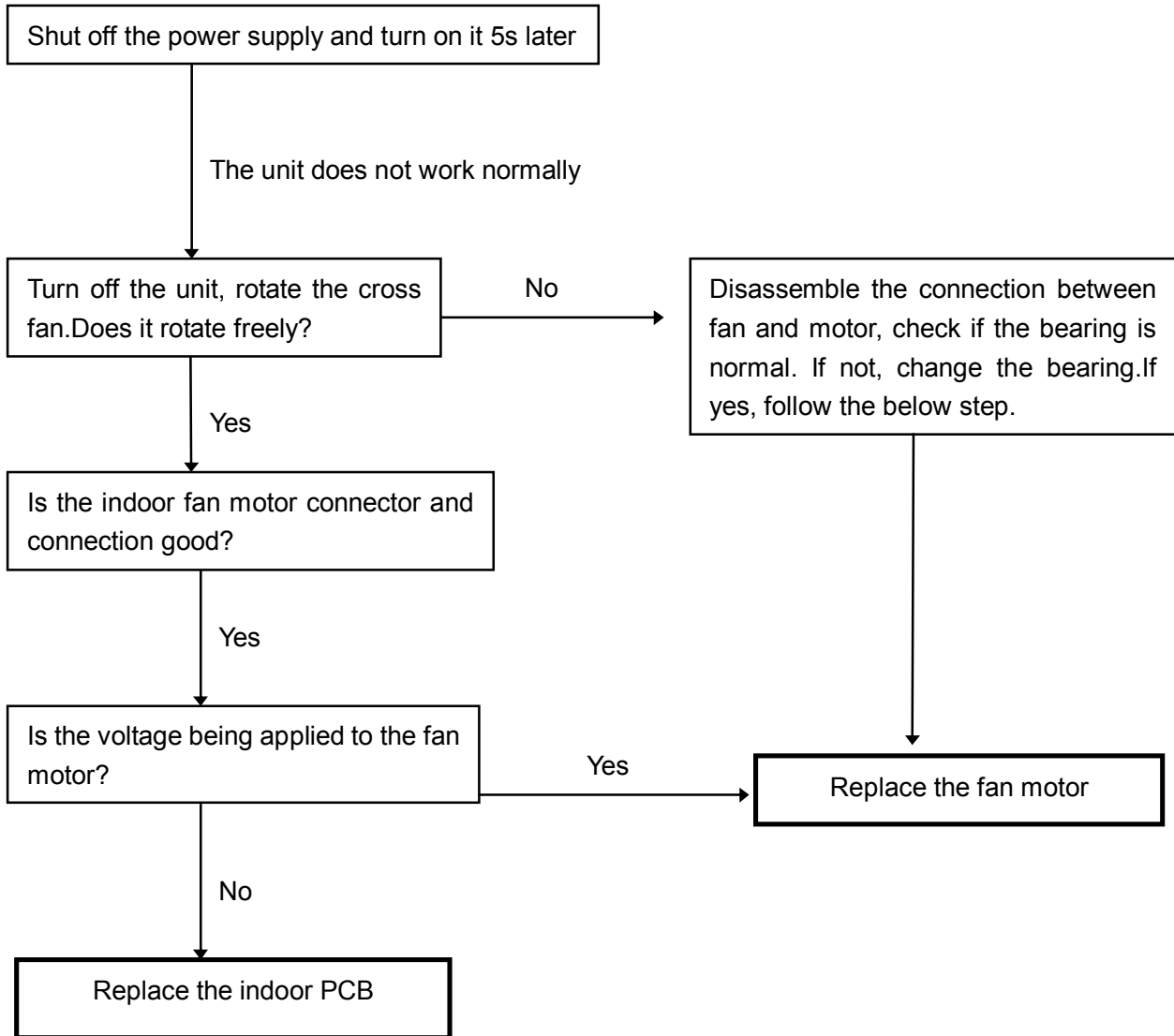

11.2.2 Open or short circuit of temperature sensor diagnosis and solution.

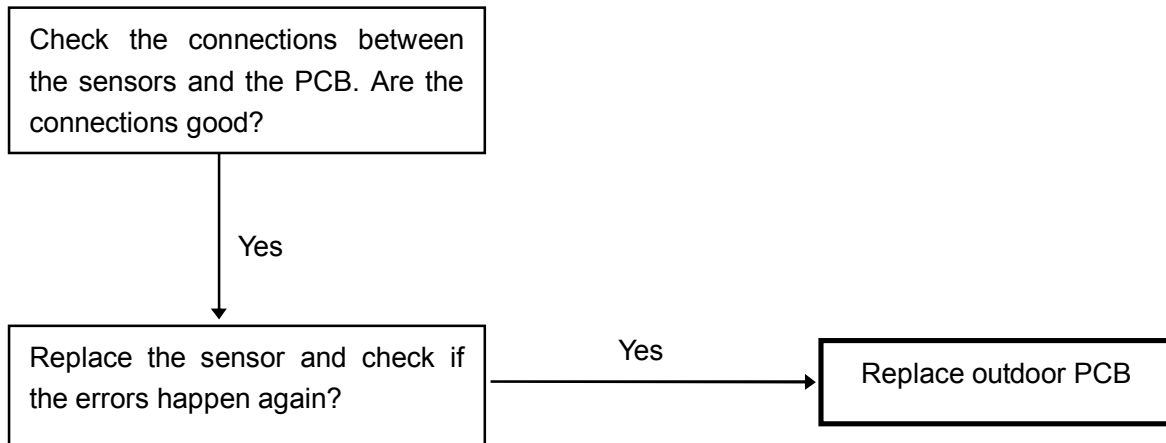

11.2.3 Over current protection occurs 4 times.

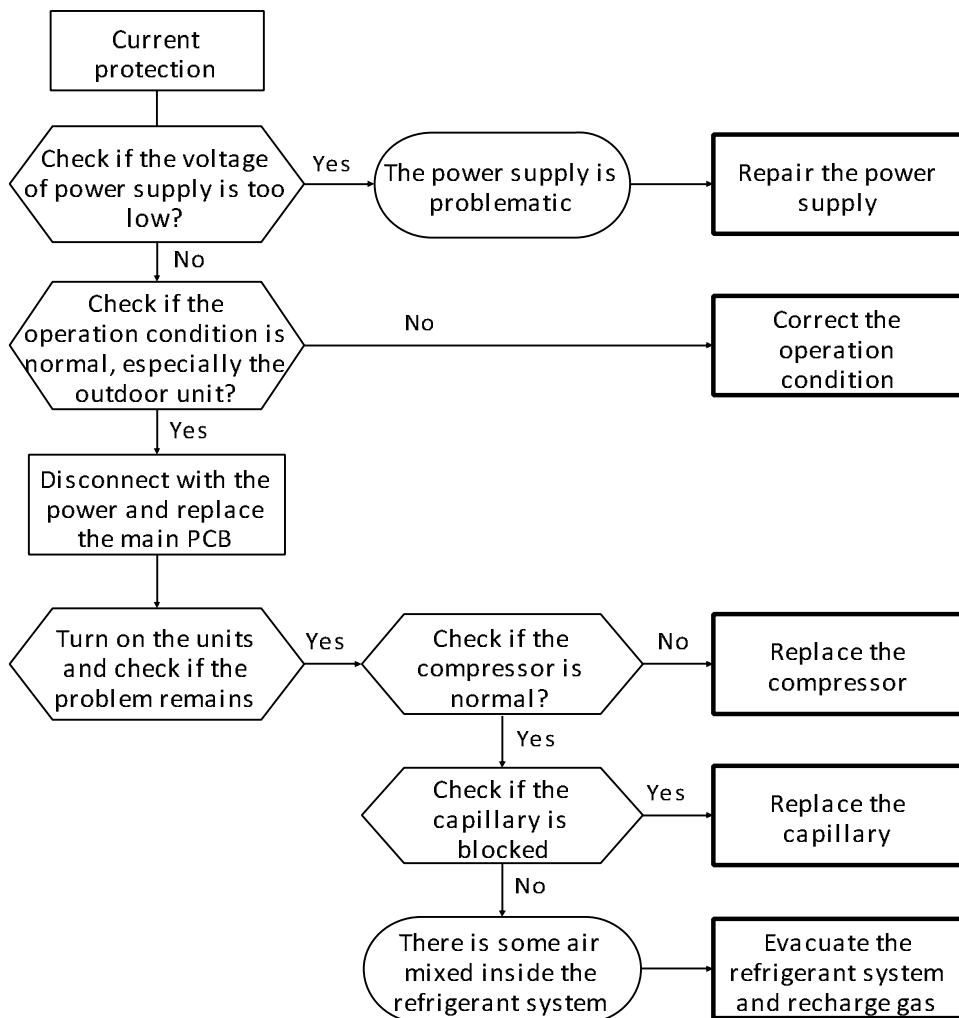

11.2.4 EEPROM parameter error diagnosis and solution

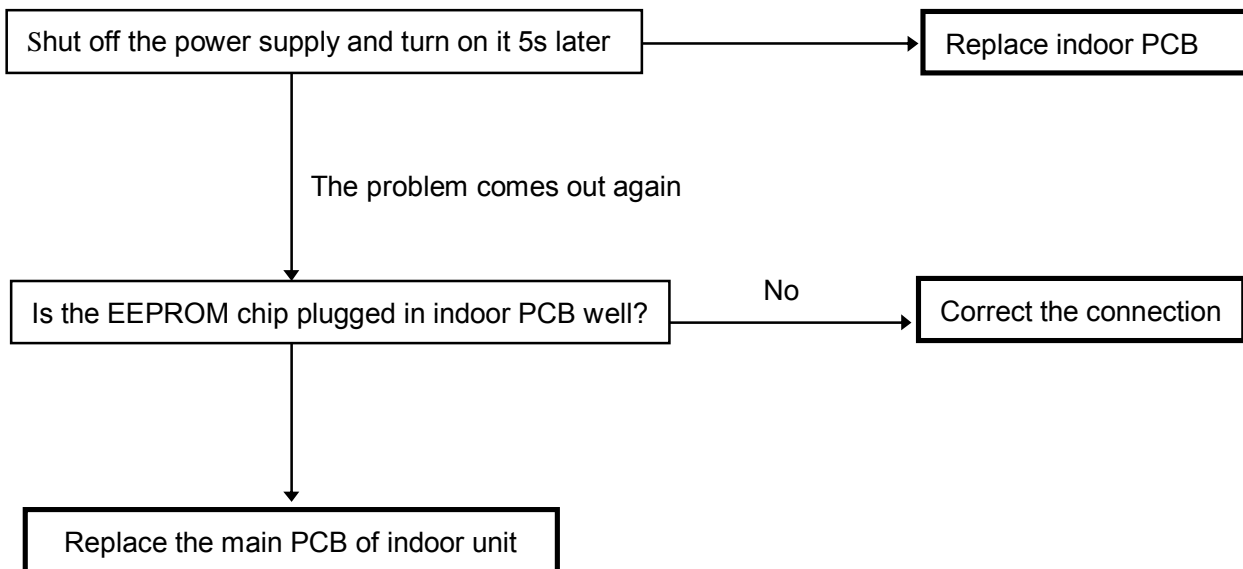

11.2.5 Zero crossing detection error

When such failure occurs, the main control board must have fault.

11.2.6 Indoor / outdoor units communication error

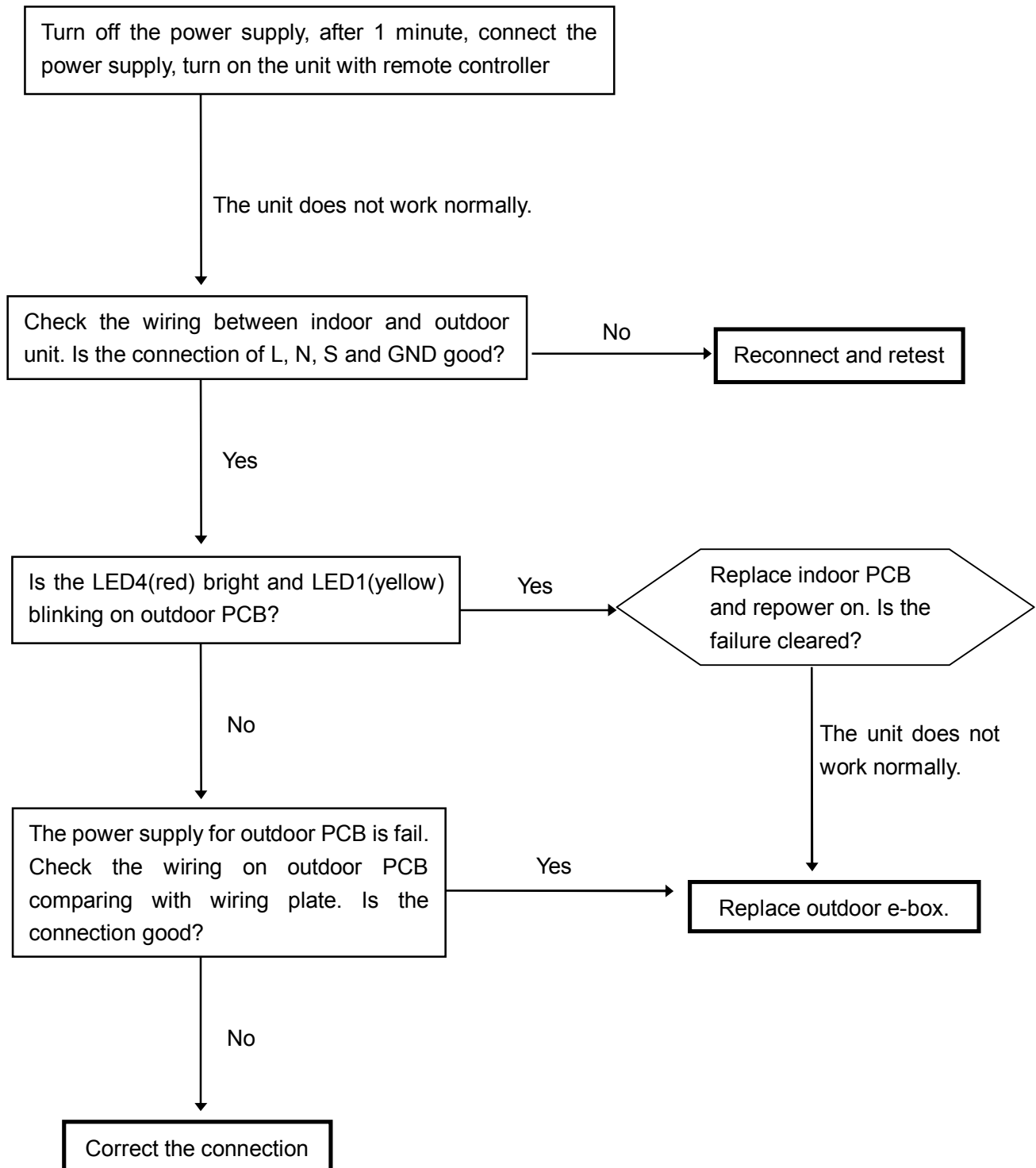

11.2.7 Outdoor units protection

