

HIGH STATIC PRESSURE DUCT TYPE AIR CONDITIONER

TECHNICAL MANUAL

AR90



FUJITSU GENERAL LIMITED

CONTENTS

1. FEATURES	2
2. DIMENSIONS	4
3. WIRING DIAGRAM	6
4. PERFORMANCE DATA	9
5. OPERATION DETAILS	11
6. INSTALLATION INSTRUCTIONS	12
7. SPECIFICATIONS	13

1. FEATURES

- **High static pressure**
 - Recommended external static pressure is 200Pa (Max. 300Pa).
- **Functional LCD wired remote controller (See the next page for details.)**
 - Weekly timer
Air conditioner ON/OFF can be set for one whole week, including 2 times a day.
 - Auto restart function in case of power failure
 - Zone control
Only preset air conditioners can be stopped by pressing the ZONE CONTROL button.
- **Energy saving operation**
 - ENERGY SAVE mode uses a computer program to economically control unit operation by raising the set temperature slightly in the cooling mode and lowering the set temperature in the heating mode.
- **Pipe length up to 50m with height differential up to 30m**
- **Easy maintenance**
 - Fan motor maintenance
Fan motor maintenance can be performed from top, bottom, right side, or left side. (Fig. 1)
Fan motor hooks to the panel and is safe and easy to mount and dismount. (Fig. 2)
- **Remote sensor unit (Option)**
 - Temperature sensor unit to be placed in the room

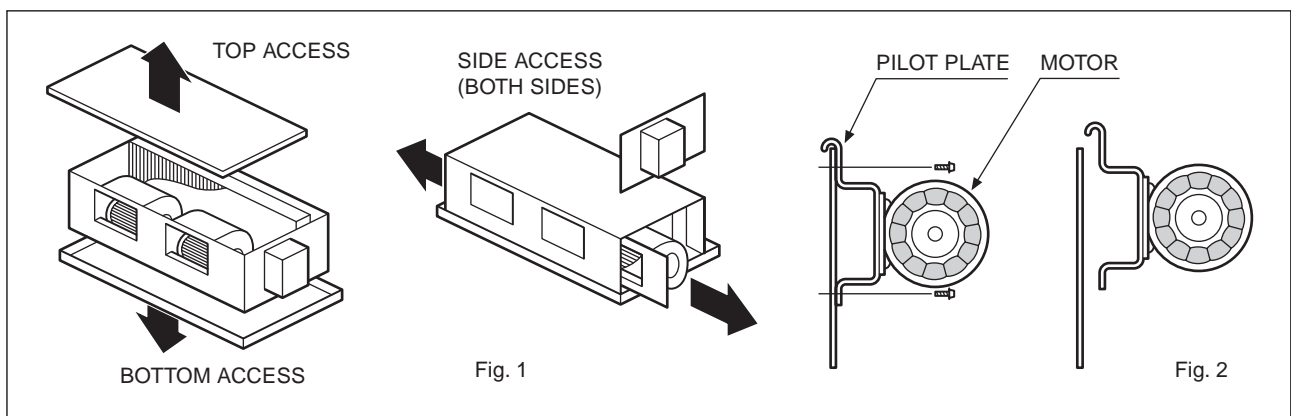

REMOTE CONTROLLER

WIRE REMOTE CONTROLLER WITH WEEKLY TIMER

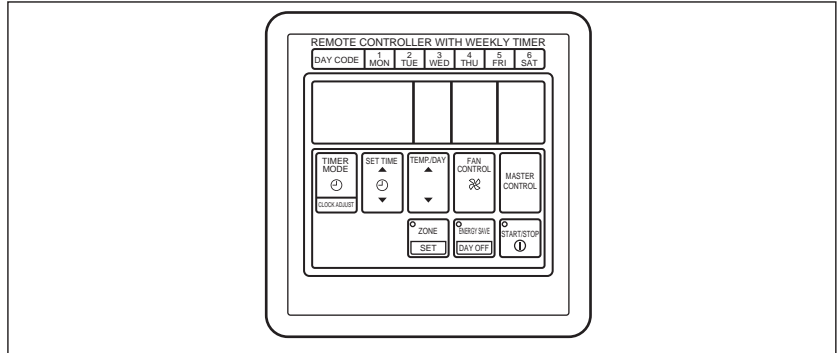

FEATURES

Three kinds of timer setup (OFF/ON/WEEKLY) are possible.

Function of weekly timer

- Setting of different on-off time by day
- Setting of set on-off time twice a day
- Setting of time in 5 minute steps
- Timer operation of a reserved day can be temporarily cancelled by pushing the "DAY OFF" button.
- Time setting can be left until the next day.

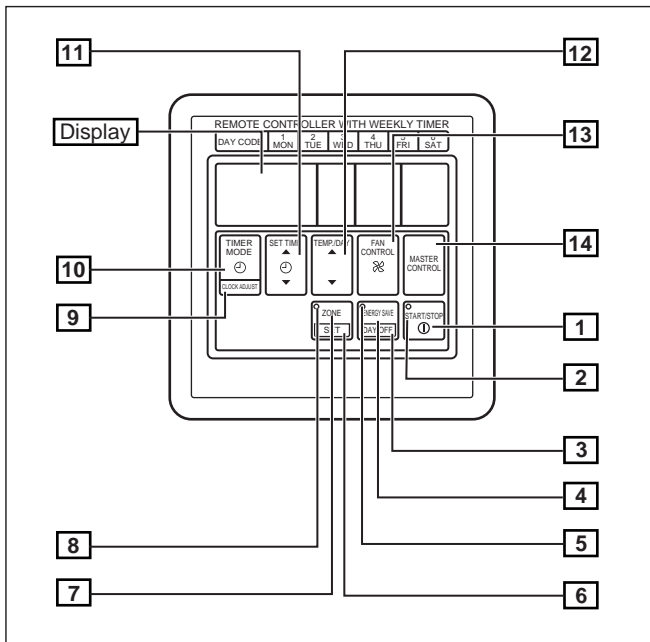

- 1 START/STOP Button
Pressed to start and stop operation.
- 2 OPERATION Lamp
Lights during operation and when the timer is on.
- 3 DAY OFF Button
Temporary cancellation of one day timer
- 4 ENERGY SAVE Button
Turns energy save mode on and off.
- 5 ENERGY SAVE Button
Lights when the unit is in the energy save mode.
- 6 SET Button
Sets the date, hour, minute and on-off time.
- 7 ZONE Button
Use to turn zone control on and off.
- 8 ZONE Lamp
Lights when the unit is in the zone control mode.
- 9 CLOCK ADJUST Button
- 10 TIMER MODE Button
Changes the timer mode (NON STOP, OFF TIMER, ON TIMER, WEEKLY TIMER).
- 11 SET TIME Button
Sets the current time and on-off time.
- 12 TEMP./DAY Button
Sets the indoor temperature / day.
- #13 FAN CONTROL Button
- 14 MASTER CONTROL Button
Selects the operating mode (HEAT, FAN, COOL).
- 15 Clock Display
- 16 Set Temperature / Day Display (TEMP./DAY)
- 17 Operation Mode Display
- 18 Timer Mode Display
- #19 Fan Speed Display
- 20 DEFROST Display
- 21 TEST Display

Display panel

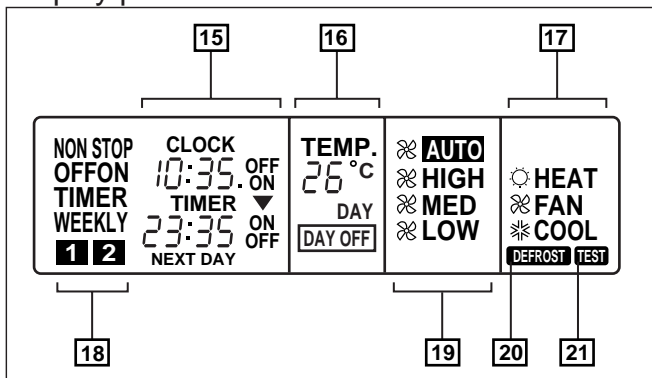

#NOTE :

This model does not have a fan speed function.

2. DIMENSIONS

INDOOR UNIT

OUTDOOR UNIT

(Unit : mm)

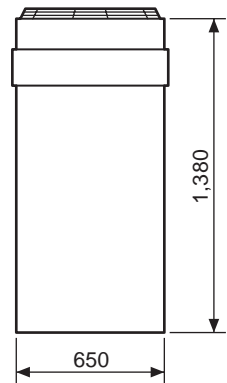
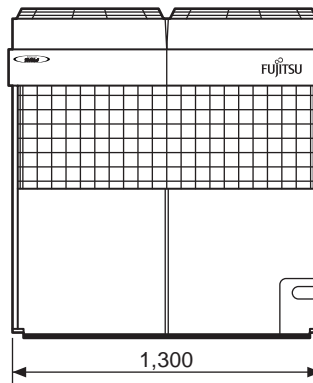
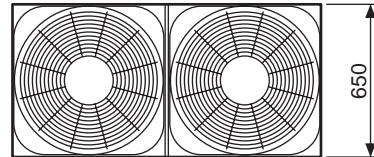
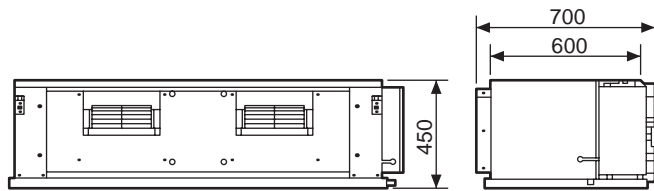
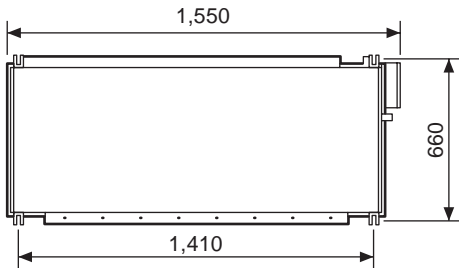

SAMPLE INSTALLATION

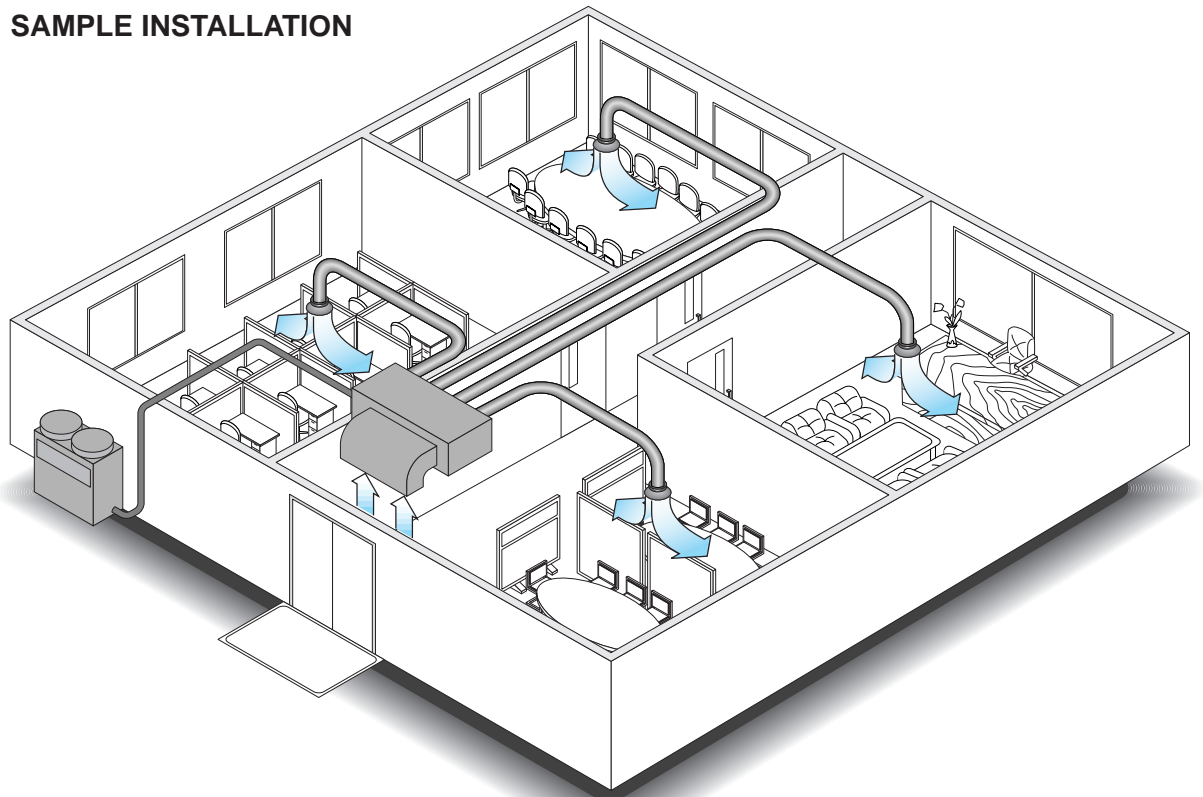

(Unit : mm)

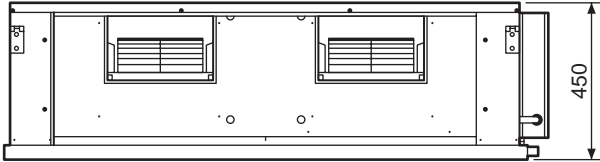
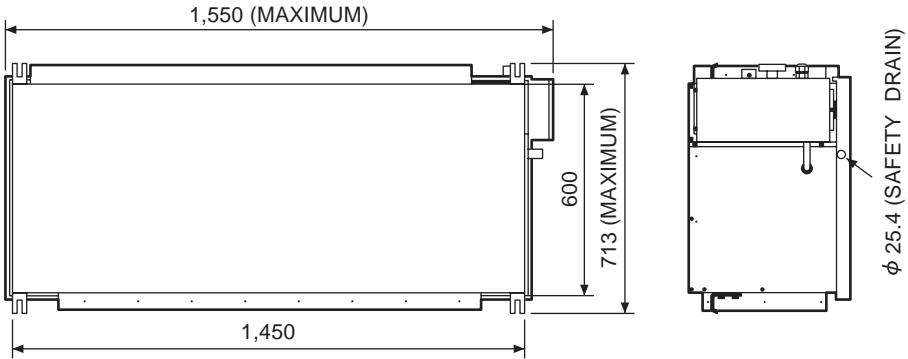
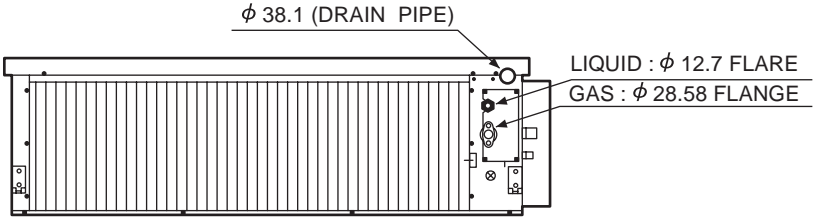
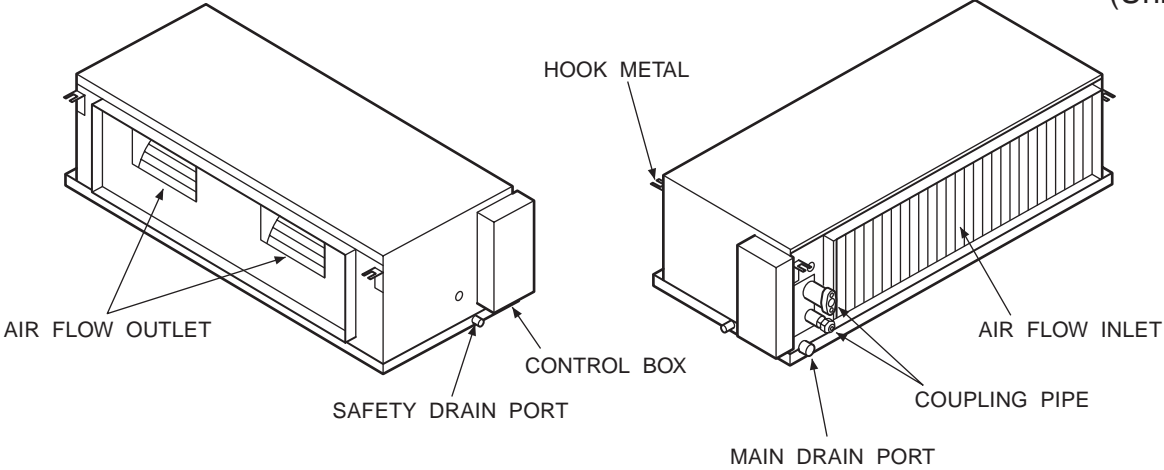

3. WIRING DIAGRAM

Models : AR□90T
AR□90E

Note :

□ { Y : Europe version
T : Australia version

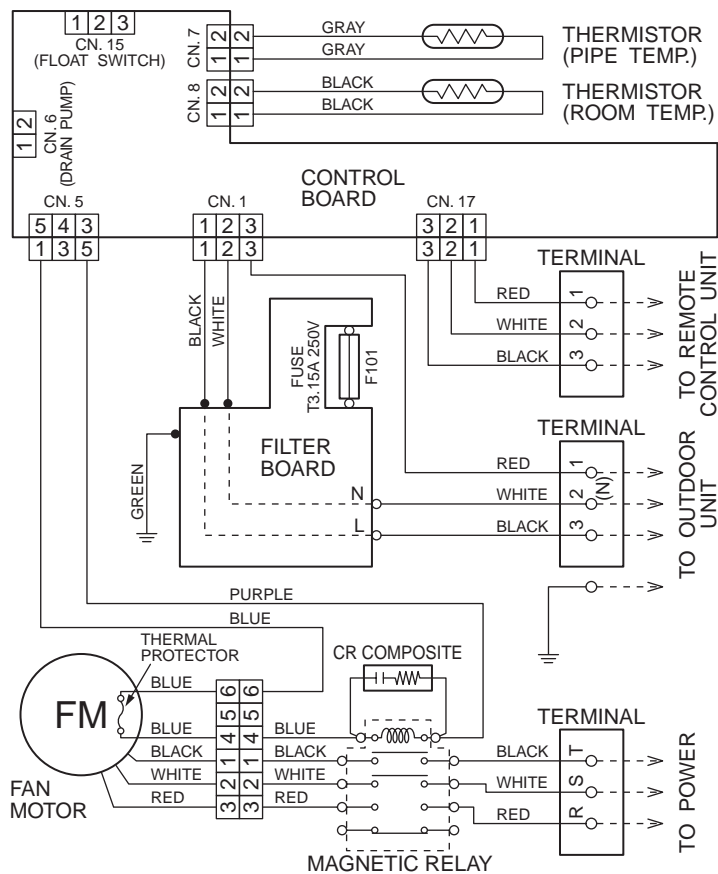

Model : AO□90EP

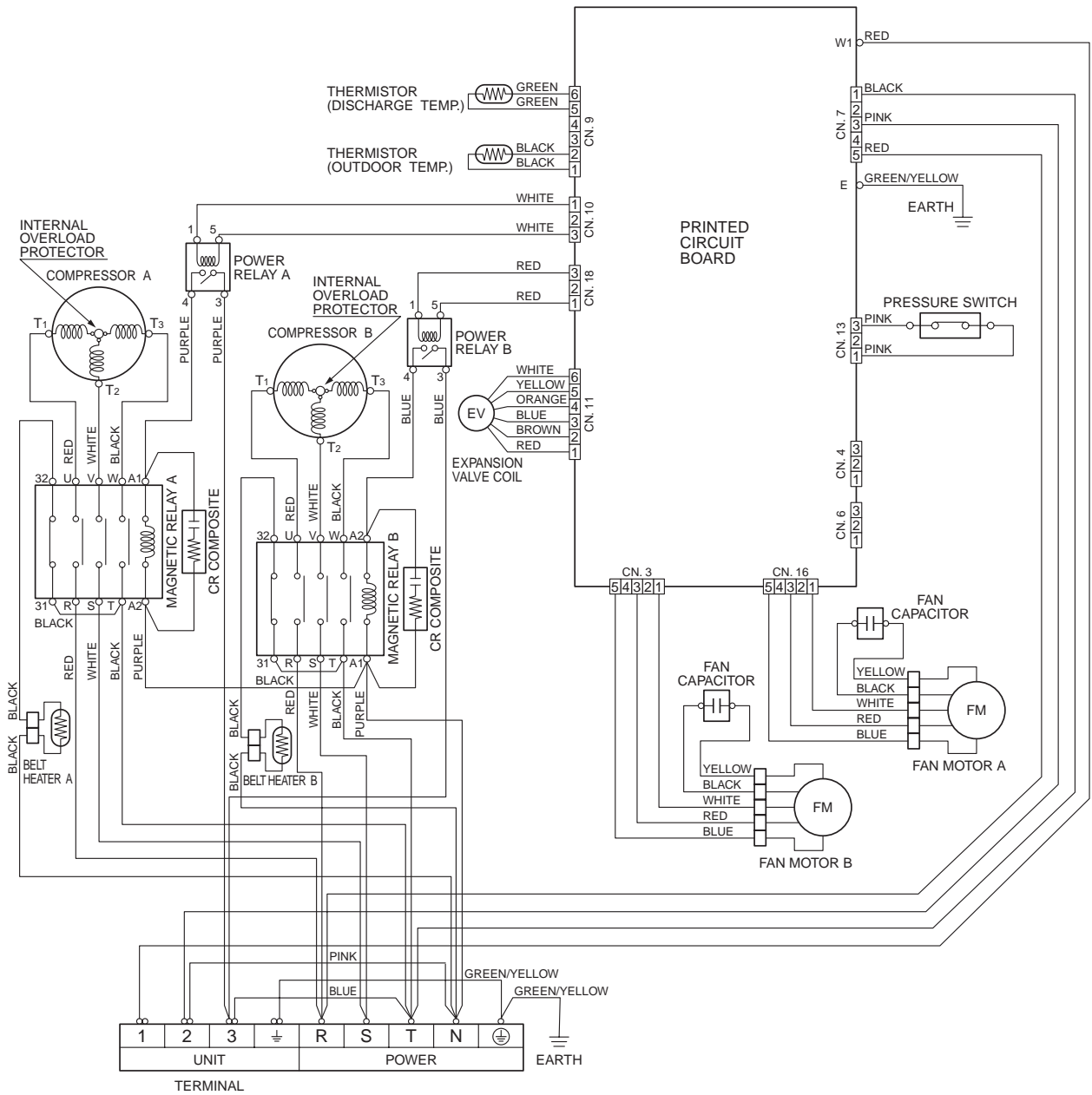

Model : AO□90TP

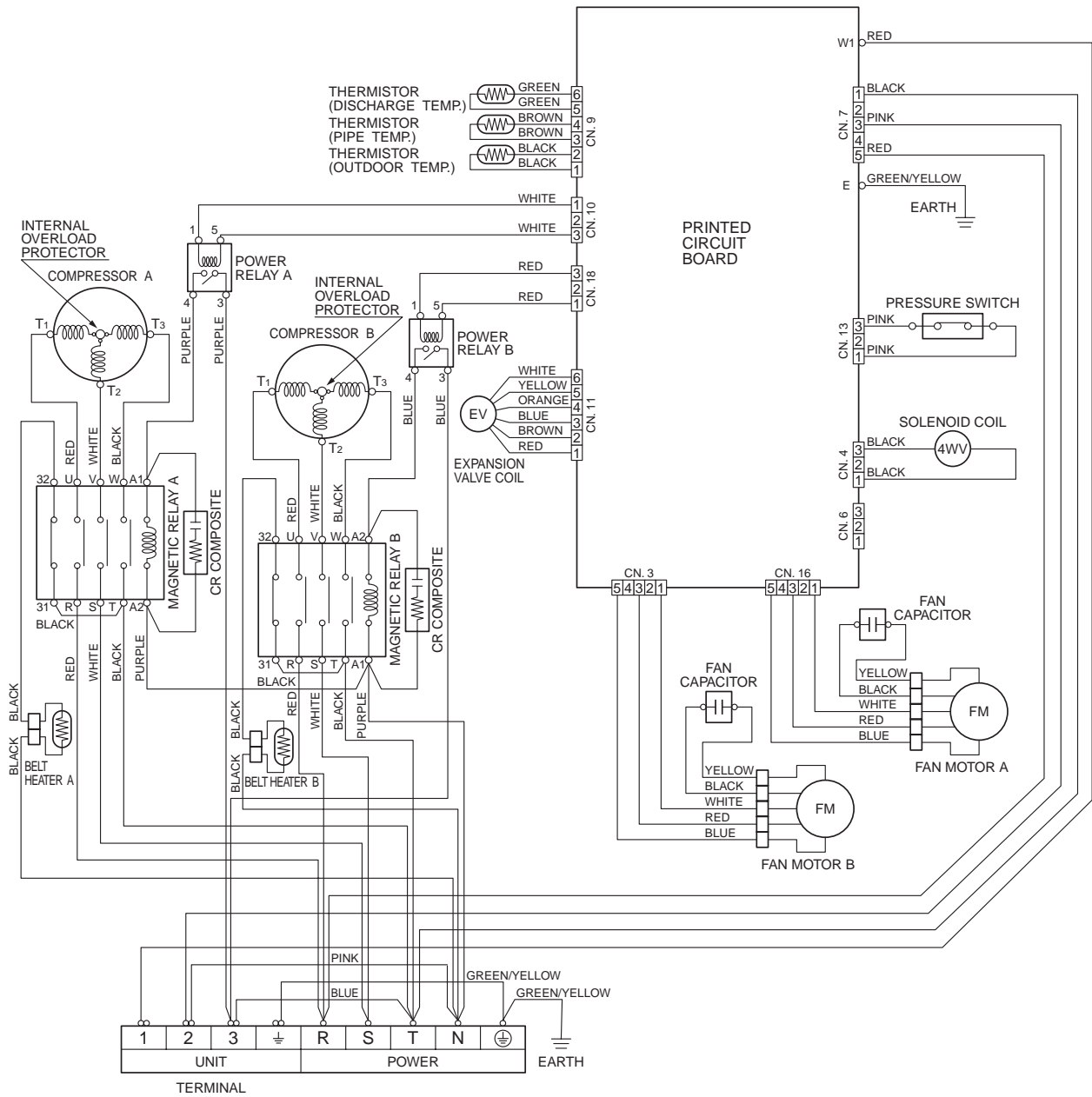

4. PERFORMANCE DATA

■ COOLING MODEL

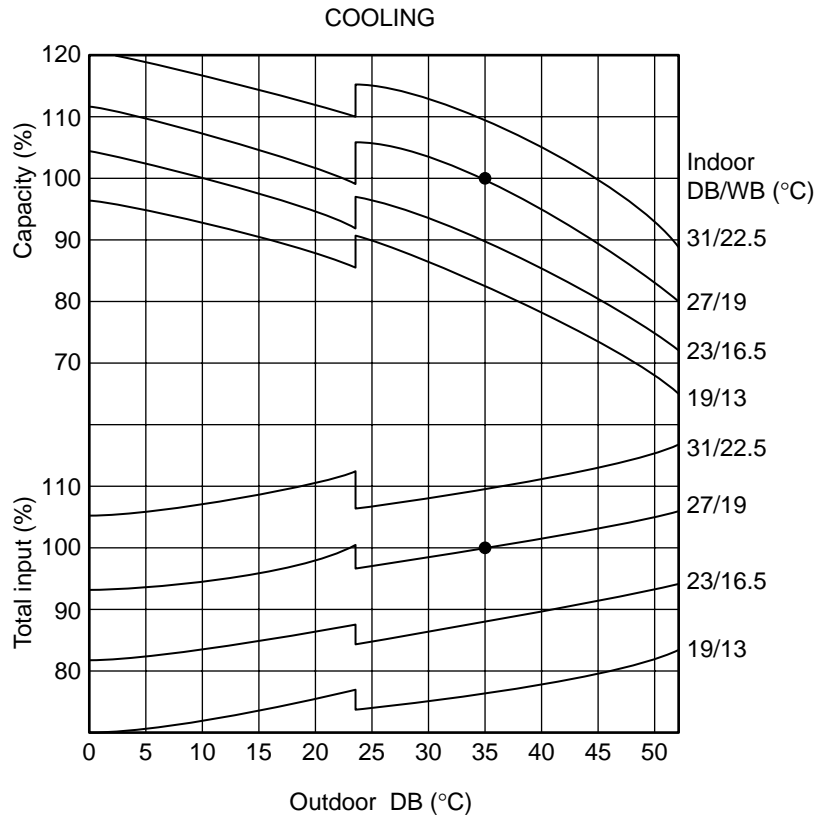

■ REVERSE MODEL

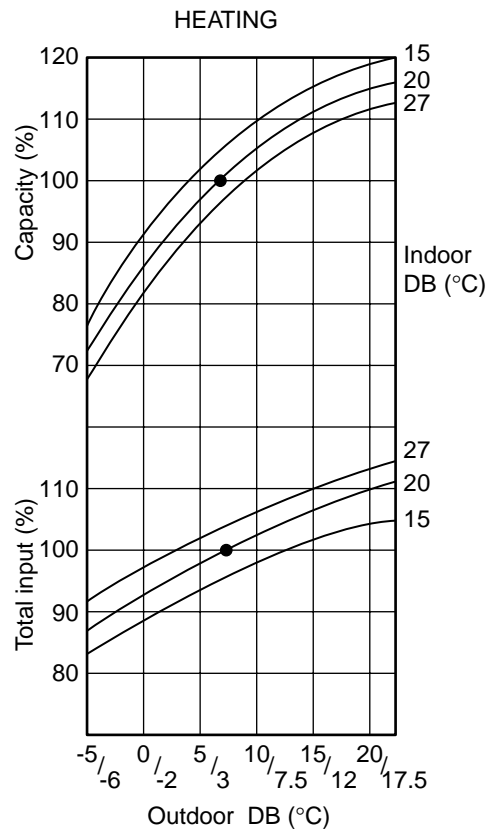
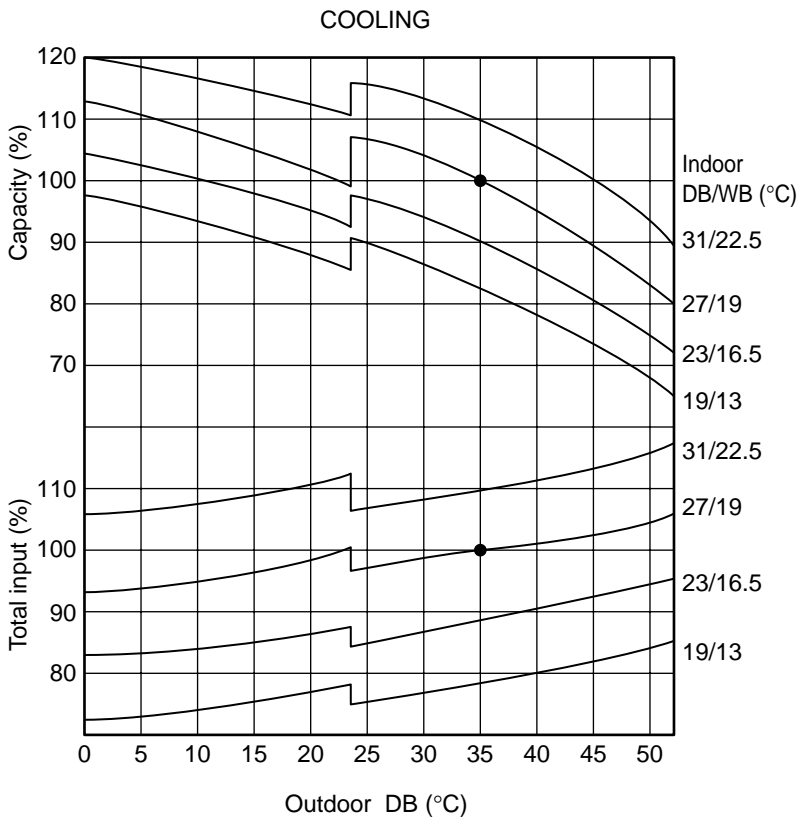

■ COOLING SENSIBLE CAPACITY

(Unit : kW)

INDOOR TEMP. (°C)		OUTDOOR TEMP. (°C)									
		25		30		35		40		45	
DB	WB	Total	Sens.	Total	Sens.	Total	Sens.	Total	Sens.	Total	Sens.
19	13	22.9	17.3	21.8	16.9	20.9	16.4	19.9	15.8	18.5	14.9
23	16.5	24.7	17.9	23.6	17.5	22.9	17.0	21.7	16.4	20.3	15.7
27	19	27.0	21.4	26.1	21.1	25.4	20.9	24.2	20.2	22.7	19.4
31	22.5	29.3	24.8	28.7	24.7	27.9	24.5	26.7	24.1	25.4	23.3

■ FAN CURVE

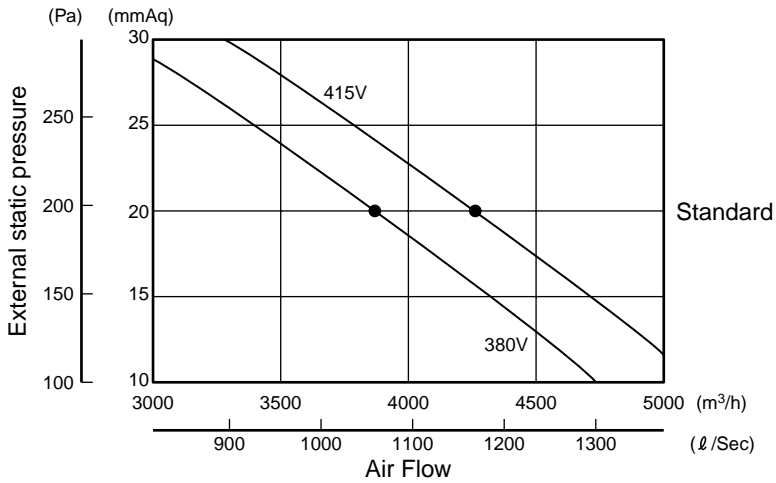

■ CAPACITY BY AIR FLOW

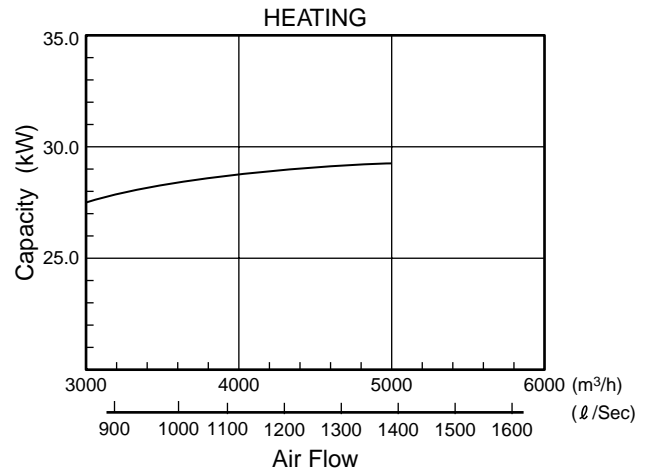
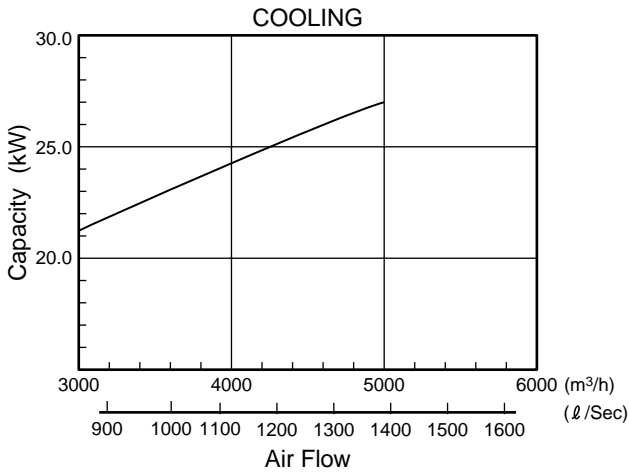

■ OUTLET AIR TEMPERATURE

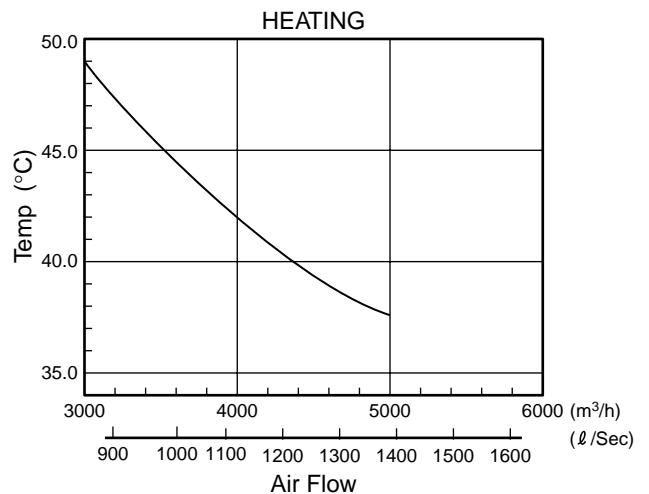
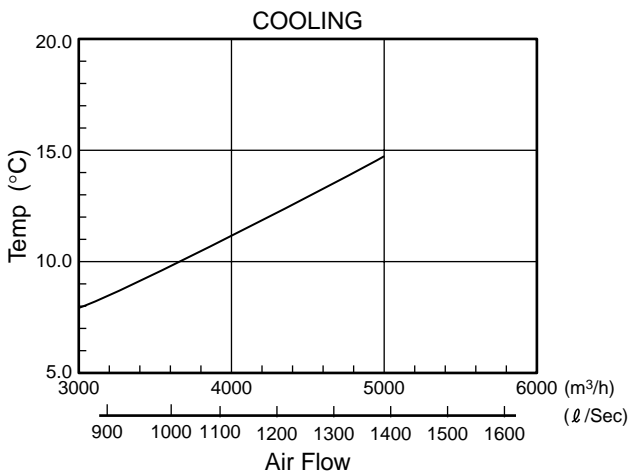

5. OPERATION DETAILS

■ TEMPERATURE AND HUMIDITY RANGE

		Cooling Mode	*Heating Mode
OUTDOOR TEMPERATURE	COOLING MODEL	Approx. 0 to 52°C	—
	HEAT & COOL MODEL (Reverse Cycle)	Approx. 0 to 46°C	Approx. -10 to 21°C
INDOOR TEMPERATURE		Approx. 18 to 30°C	Approx. below 30°C
INDOOR HUMIDITY		Approx. 80% or less	—

- Do not use this unit for any purpose other than the cooling, (*) heating, dehumidifying and circulating air of rooms in ordinary dwellings.

■ REFRIGERANT CHARGE

Actual pipe length	30m (99ft)	40m (132ft)	50m (164ft)	Additional refrigerant (R407C)
Full charge amount HEAT & COOL MODEL	7,000g (247 oz)	8,000g (282 oz)	9,000g (317 oz)	100g/m (3.5 oz / 3.3 ft)
Full charge amount COOLING MODEL	6,000g (212 oz)	6,500g (229 oz)	7,000g (247 oz)	50g/m (1.8 oz / 3.3 ft)

⚠ CAUTION	
<p>Do not purge the air with refrigerants but use a vacuum pump to vacuum the installation! There is no extra refrigerant in the outdoor unit for air purging!</p> <p>Use a vacuum pump for R407C exclusively. Using the same vacuum pump for different refrigerant may damage the vacuum pump or the unit.</p> <p>When moving and installing the air conditioner, do not mix gas other than the specified refrigerant R407C inside the refrigerant circuit.</p> <p>When charging the refrigerant R407C, always use an electronic balance for refrigerant charging (to measure the refrigerant by weight).</p> <p>When charging the refrigerant, take into account the slight change in the composition of the gas and liquid phases, and always charge from the liquid phase side whose composition is stable.</p> <p>Add refrigerant from the charging valve after the completion of the work.</p> <p>Use a brand-new refrigerant piping when replacing the air conditioner using the refrigerant except R407C and R410A.</p>	<p style="text-align: center;">Gauge manifold</p> <p style="text-align: center;">Vacuum pump</p> <p style="text-align: center;">Service hose</p>

6. INSTALLATION INSTRUCTIONS

INDOOR UNIT

SERVICE SPACE

Leave the space required to service the air conditioner. (Fig.1)
 (1) If a service hole is provided at the bottom of the product.

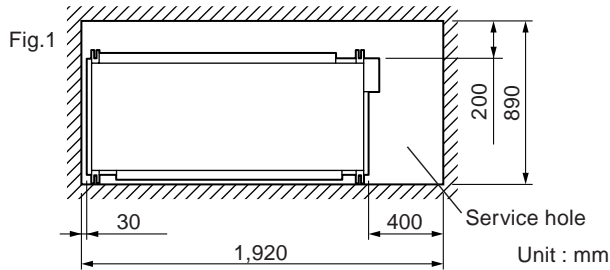

(2) If the service hole referenced in (1) is not provided.

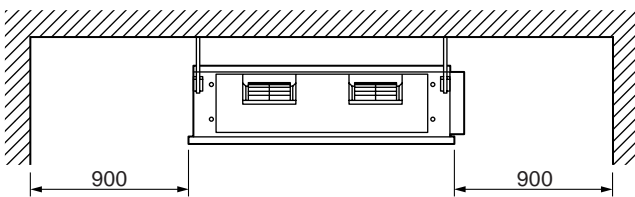

INSTALLING DRAIN PIPE

Position of drain piping and refrigerant piping.

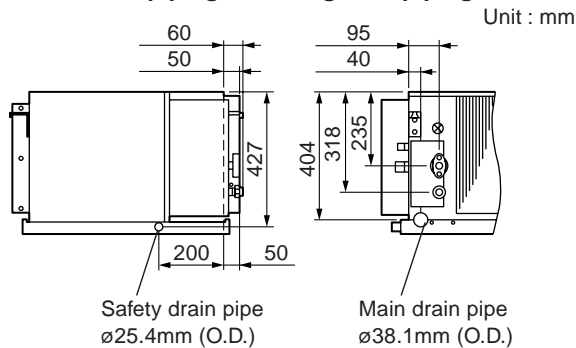

The installed drain pipe should have a downward gradient of 1/50 to 1/100. Make sure that the drain pipe is installed without rises. Use general hard polyvinylchloride pipe (VP25) and connect it with adhesive (polyvinylchloride) so that there is no leakage. Do not perform air bleeding.

Main drain

On the main drain, provide one trap near the indoor unit.

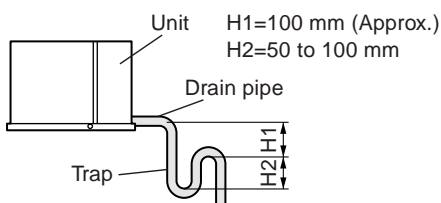

Safety drain

There is no need to provide a trap for the safety drain. If the safety drain is connected to the main drain, make the connection below the main trap.

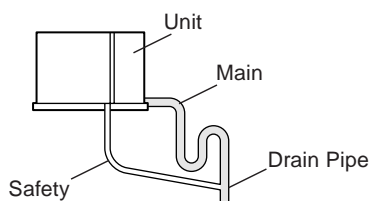

Once installation is complete, check the flow of drain water.

INSTALLING THE DUCT

Follow the procedure in the following figure to install the duct.
Flange positions for connecting the duct.

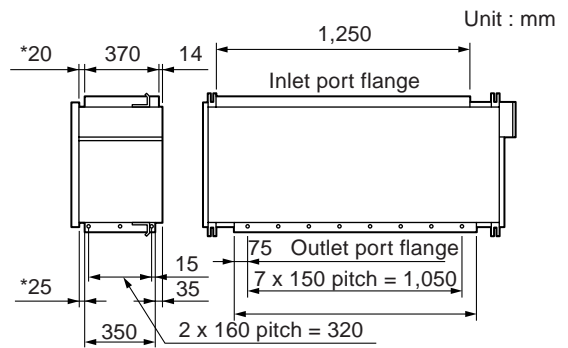

*Spacing between flange and drain pan

Install the air inlet grille for air circulation. The correct temperature cannot be detected.

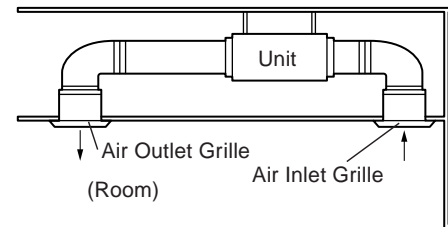

OUTDOOR UNIT

Provide the space shown in Fig.2 so that the air flow is not blocked.

Installing the unit individually

Fig. 2

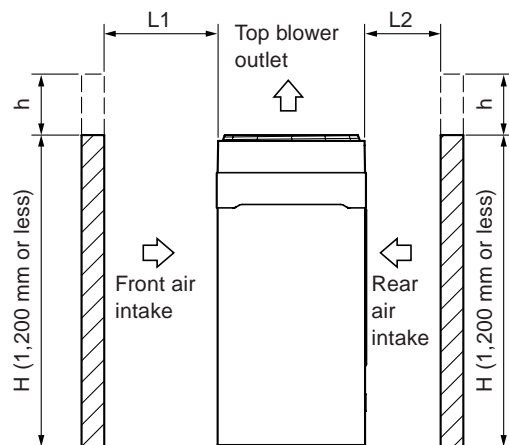
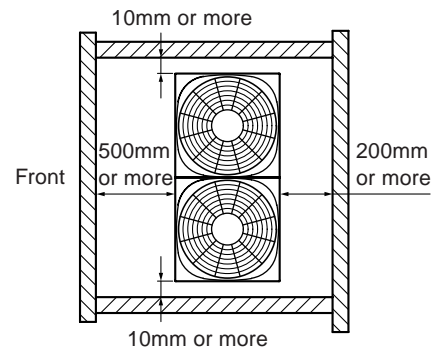

- There is no limit to the height of the side wall.
- The height of the wall (H) at the front and rear should be 1,200mm or less.
- If the wall height exceeds 1,200mm, add dimension (h) to the respective service space dimensions L1 and L2.

7. SPECIFICATIONS

TYPE			DUCT TYPE AIR CONDITIONER	
			COOLING ONLY TYPE	COOLING & HEATING TYPE
Model	Indoor Unit		AR□90E	AR□90T
	Outdoor Unit		A0□90EP	A0□90TP
Input Power		V/φ/Hz	380 - 415 / 3 / 50	
Capacity	Cooling	kW	24.8 - 25.4	
		BTU/h	84,500 - 86,500	
	Heating	kW	—	
		BTU/h	98,500 - 100,500	
Ampacity	Cooling	A	18.3 - 17.6	
	Heating		—	
Input Watts	Cooling	kW	11.0 - 11.0	
	Heating		—	
Starting Current		A	63	
Moisture Removal		ℓ/h	7.5	
E.E.R.	Cooling	kW/kW	2.25 - 2.31	
	Heating		—	
Fan Speed	Indoor	r.p.m.	1,140 When static pressure is 200Pa	
	Outdoor		730	
Air Flow	Indoor	m ³ /h (ℓ/s)	4,300 (1,194) When static pressure is 200Pa	
	Outdoor		5,800 (1,611)	
Standard Static Pressure		Pa	200	
Dimensions H x W x D	Net	Indoor	450 x 1,550 x 700	
		Outdoor	1,380 x 1,300 x 650	
	Gross	Indoor	550 x 1,750 x 825	
		Outdoor	1,535 x 1,400 x 700	
Weights Net / Gross		Indoor	85 / 100	
		Outdoor	243 / 280	245 / 282
Refrigerant Type		—	R407C	
Connection Method / Pipe Size		—	Flange / φ28.58 (Large)	Flare / φ12.70 (Small)
Max. Pipe Length / Height		m	50 / 30	
Operation Range	Cooling	°C	0 to 52	
	Heating		—	
			0 to 46	
			-10 to 21	

Note :

□ { Y : Europe version
T : Australia version



FUJITSU GENERAL (Euro) GmbH

A SUBSIDIARY OF FUJITSU GENERAL LIMITED

Wertstraße 20, D-40549 Düsseldorf, F.R. Germany

TEL : (49) 211 50098 0

FUJITSU GENERAL (U.K.) CO. LIMITED

A SUBSIDIARY OF FUJITSU GENERAL LIMITED

Ground Floor, Elstree House, Elstree Way, Borehamwood, Herts WD6 1LS United Kingdom

TEL : (44) 181 421 7000

FUJITSU GENERAL(AUST.) PTY LIMITED

ACN 001 229 554

A SUBSIDIARY OF FUJITSU GENERAL LIMITED

HEAD OFFICE

SYDNEY : 100 Holbeche Road, Arndell Park, N.S.W. 2148 TEL: (02) 8822 2500

MELBOURNE : Unit 7, 14 Lionel Road, Mount Waverley, VIC. 3149 TEL: (03) 9543 5899

(also all Tasmanian enquiries)

BRISBANE : Suite 1, Level 5, 301 Coronation Drive, Milton, QLD. 4064 TEL: (07) 3367 2008

ADELAIDE : 146 Fullarton Road, Rose Park, S.A. 5067 TEL: (08) 8364 0588

PERTH : Suite 3, 5 Mumford Place, Balcatta W.A. 6021 TEL: (08) 9240 5877

FUJITSU GENERAL NEW ZEALAND LIMITED

A SUBSIDIARY OF FUJITSU GENERAL LIMITED

HEAD OFFICE

WELLINGTON : Level 1, 8-10 Fitzherbert Street, Petone, New Zealand TEL: (04) 568 8761